

Unité de mortaisage

La nouvelle unité de mortaisage pour la fabrication économique de rainures et de cannelures.

Un investissement rentable.



Voir en action :



Mortaisage intérieur et extérieur

Même outil de coupe pour usinage intérieur et extérieur – à inverser simplement.

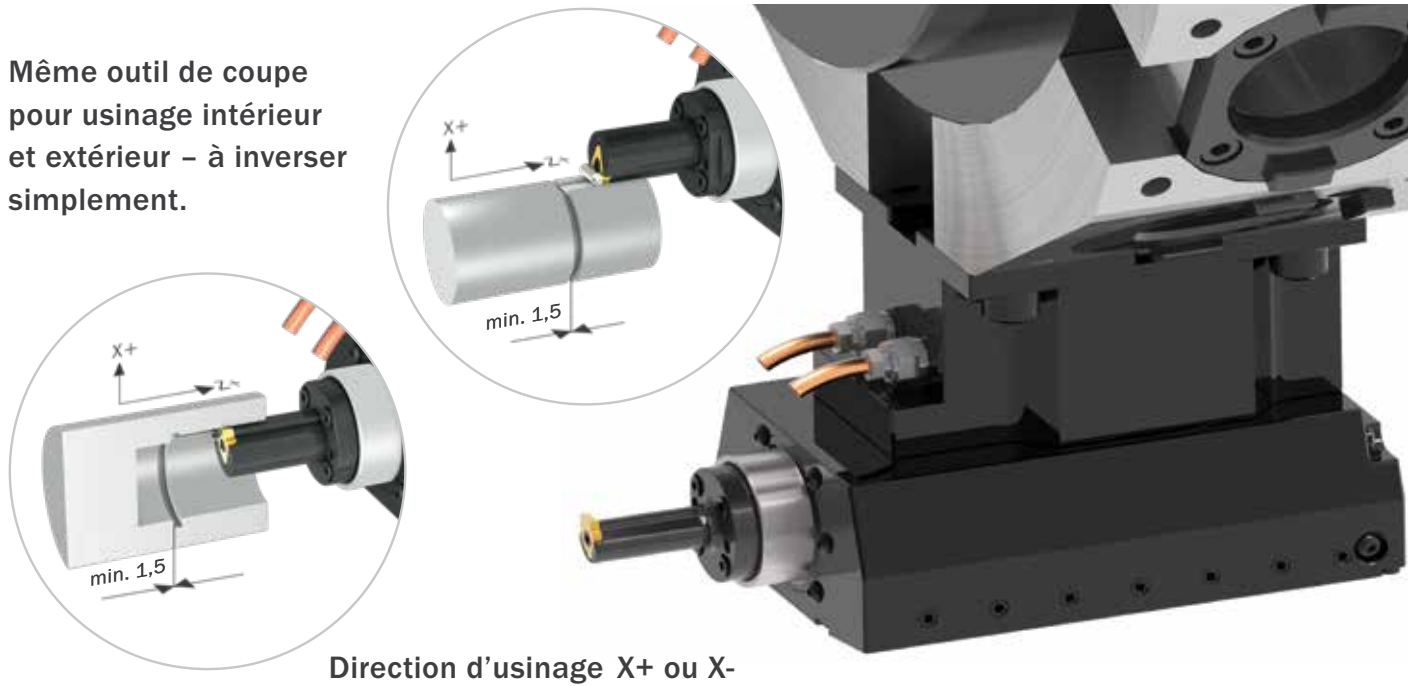

Fonction

1
Positionner
l'outil en Z



2
L'outil coupe
la matière



3
L'outil se lève



4
Le levage évite l'usure
et la casse de l'outil
pendant le retour



Exemples d'usinage

Rainure à clavette

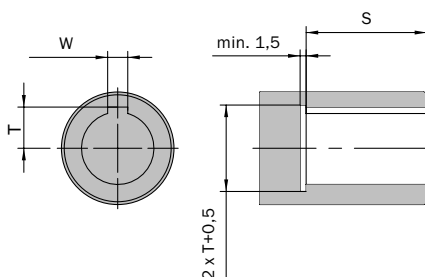

Cannelure intérieure
selon DIN 5482

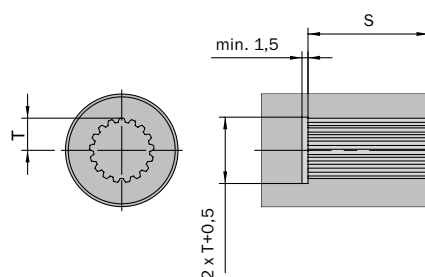

Cannelure extérieure
selon DIN 5480

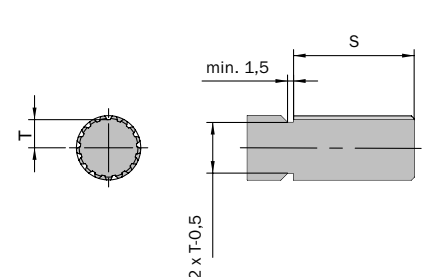

Unité de mortaisage pour tourelles radiales



Type 26 / 32 / 52

Unité de mortaisage pour tourelles axiales



Type 32 / 52

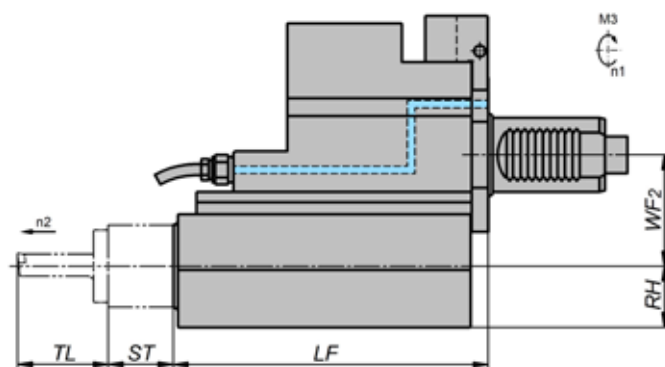
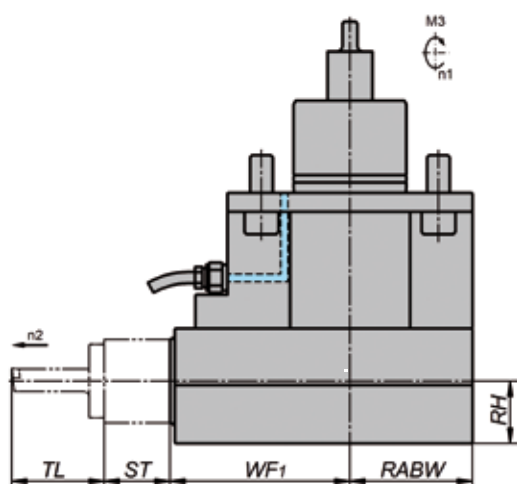

Type	Course utile (S)	Course totale	Largueur de rainure maximale (W)	Matières [N/mm ²]	Vitesse maximale [1/min] (n2)	Rapport de transmission	Avance maximale par coup
26	26	28	6	1200	1500	2:1	0,15
32	32	35	12	1200	1000	1:1	0,15
52	52	55	12	1200	800	1:1	0,15

Type	TL	ST	LF	WF1	WF2	RABW	RH
26	38	28	-	59	-	61	30,5
32	49	35	170	95,5	60	65	33
52	67	55	180	105,5	65	74	33

Dimensions en mm

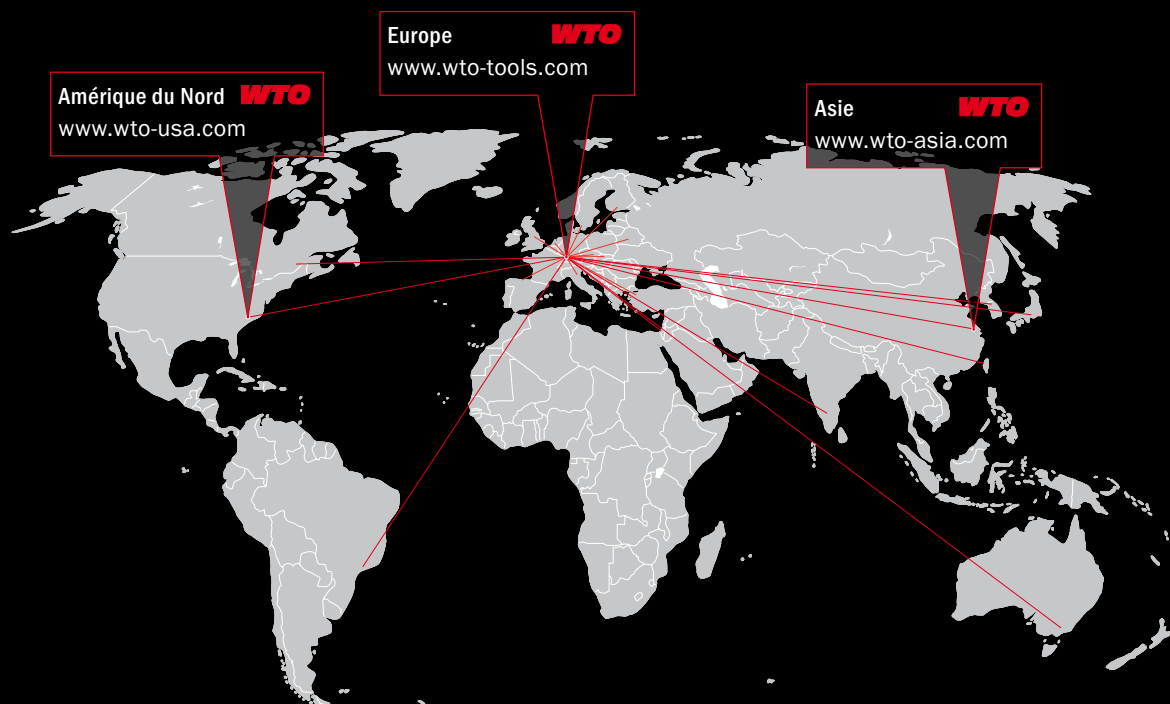

WTO Werkzeug-
Einrichtungen GmbH
Neuer Hohdammweg 1
77797 Ohlsbach
Allemagne

WTO Inc.
13900-F South Lakes Dr.
Charlotte, NC 28273
États-Unis

WTO Asia
WTO Precision Tool Holders
(Shanghai) Co. Ltd.
Room 109-110, Building 2
No. 228 Banting Road
Jiuting Town,
Songjiang District
201615 Shanghai
Chine

Partenaires de distribution – la compétence sur place

Australie

Dimac Tooling Ltd.
sales@dimac.com.au

Brésil

TF2
tfdois@tfdois.com.br

Canada

Mittmann Industrial Inc.
info@mittmann.com

Chine

Shanghai Gangde
wtocando@yahoo.com

Corée

WTO Office Korea
is.chon@wto-korea.com

Danemark

AVN Teknik A/S
cjo@avn.dk

Espagne

ITALMATIC, S.A.
italmatic@italmatic.es

Finlande

Suomen Terätuonti Oy
myynti@stt.as

France Est

Christophe Archambault
alm@wto.de

France Ouest

Christophe Archambault
car@wto.de

Grande Bretagne

Cutwel Ltd.
sales@cutwel.net

Hongrie

Prevotex Hungary Kft.
info@prevotex.hu

Inde

Ulhas Patil
u.patil@wto-asia.com

Israël

E.Y.A.R. Ltd.
boris@eyar.co.il

Italie

Prymark srl
commerciale@prymark.it

Japon

NK Works Co. Ltd.
k_samba@nk-works.co.jp

Mexique

Workholding Engineering De México
info@wem.com.mx

Norvège

Helge Karlsen Verktøy og Maskin AS
hkvm@hkvm.no

Pays-Bas

Toologic BeNeLux B.V.
info@toologic-benelux.nl

Pologne

ARCO Andrzej Rudenko
info@arcotools.pl

République Tchèque

ALBA precision, spol. s.r.o.
info@albaprecision.cz

Roumanie

SC Elif Trading SRL
bulent.ozkan@eliftrading.com

Suède

Bonthron & Ewing AB
info@bonthron-ewing.se

Suisse

Utilis AG
info@utilis.com

Slovaquie

ALBA precision s.r.o.
albaprecision@albaprecision.sk

Taiwan

Kaiko Co., Ltd.
info@kaiko.com.tw

Turquie

MYK CNC MAKINA SAN. VE
huseyin.tatlidil@mykcnc.com.tr

Ukraine

«LLC» SPA Stankopromimport
info@phoenix-ua.com