

Programme de porte-outils

ALX 1500, 2000, 2500
NLX 2500 (tourelle statique)
NLX 1500, 2000, 2500, 3000
NLX 1500, 2000, 2500 (20 ST)
NLX 4000
NLX 6000
NTX 500 (BMT40)
NTX 500 (BMT42/64)
NTX 1000, 2000, 2500, 3000 Gen. 2 (BMT40)
NTX 2000, 2500, 3000 Gen. 2 (BMT60)
NT 4200, 4250, 4300, 5400

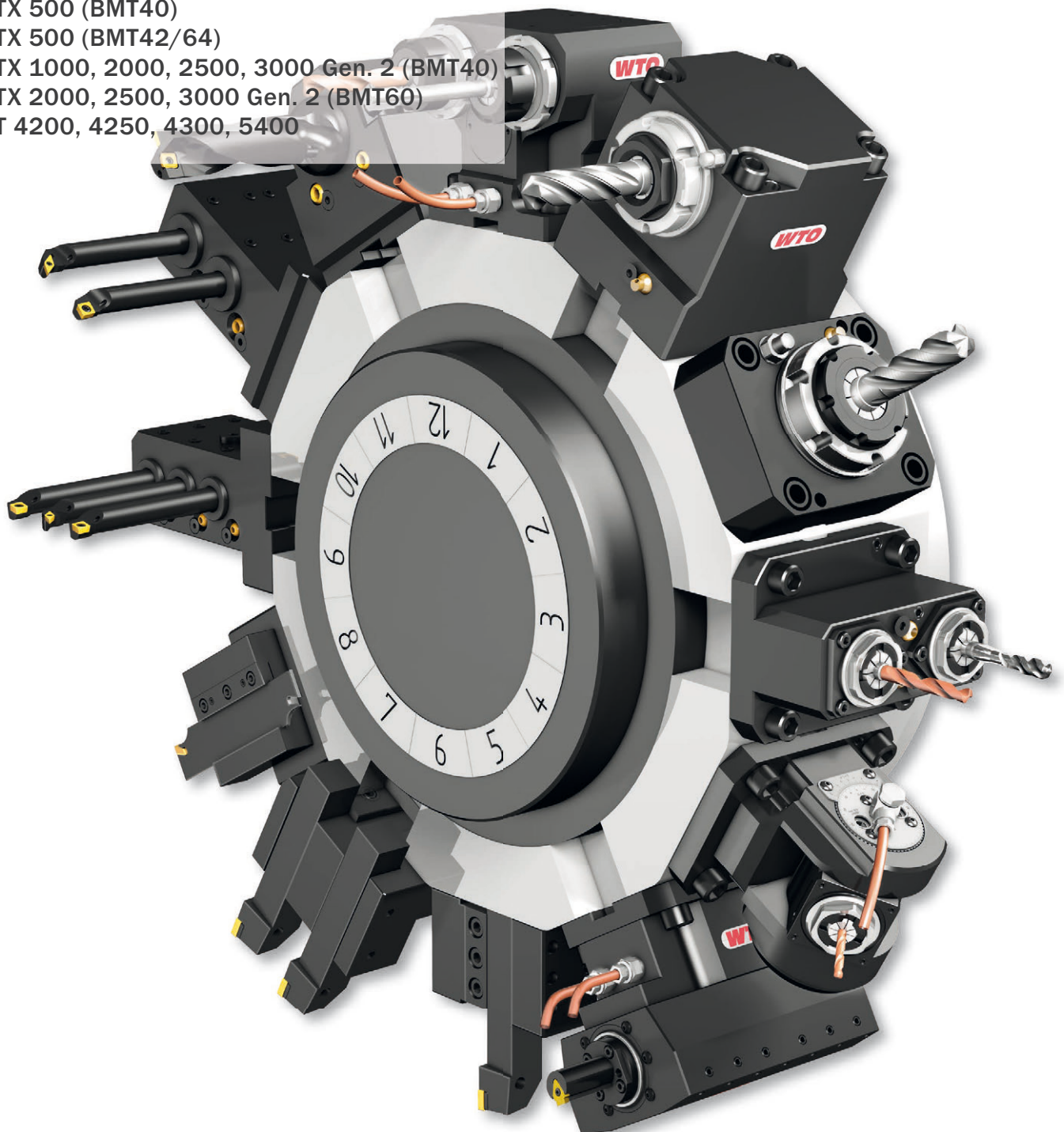

DMG MORI



QuickFlex®

Le nouveau système de changement rapide pour haute performance et précision.

Investissement minimal, possibilité d'extension maximale.

Développé
pour



ALX 1500, 2000, 2500	Page	4 - 9
NLX 2500 (tourelle statique)	Page	10 - 10
NLX 1500, 2000, 2500, 3000	Page	11 - 18
NLX 1500, 2000, 2500 (20 ST)	Page	19 - 25
NLX 4000	Page	26 - 32
NLX 6000	Page	33 - 34
NTX 500 (BMT40)	Page	35 - 40
NTX 500 (BMT42/64)	Page	41 - 42
NTX 1000,2000,2500,3000 Gen.2(BMT40)	Page	43 - 49
NTX 2000, 2500, 3000 Gen. 2 (BMT60)	Page	50 - 54
NT 4200, 4250, 4300, 5400	Page	55 - 60
Douilles de réduction	Page	61 - 63
Pinces	Page	64 - 66

EC = Arrosage externe

HP-IC = Arrosage interne haute pression par l'intérieur de l'outil coupant

IC 80 bar = Arrosage interne et externe

Pression maximale = 80 bar

IC 30 bar = Arrosage interne et externe

Pression maximale = 30 bar

Utiliser uniquement du fluide filtré (taille max. de particules = 50 µm)

Ne pas faire tourner sans arrosage!

Ne pas utiliser pour l'usinage de matériaux abrasifs,
comme de la fonte grise par exemple.

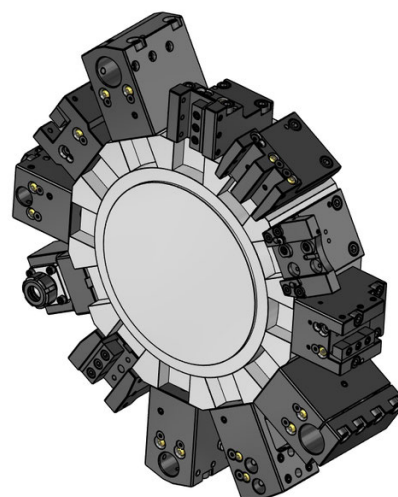
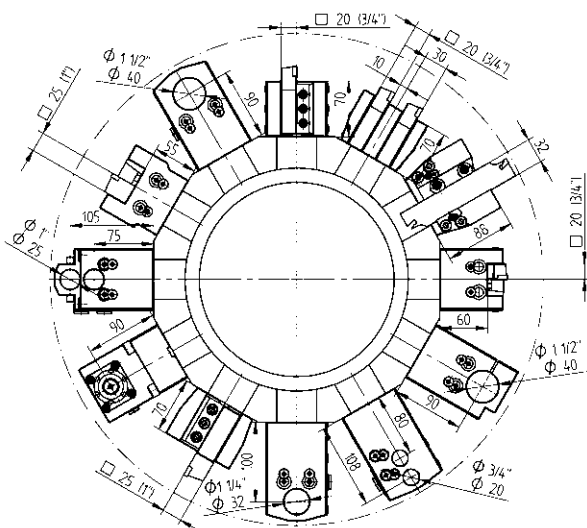

Porte-outils fixes - Programme standard



Porte-outil radial, court

- 20 48-T00224
T00224
- 25 48-T00267
T00267



Porte-outil radial, court, HP-IC

- 20 48-T00224-HP IC 80 bar
T00224
- 25 48-T00267-HP IC 80 bar
T00267



Porte-outil radial, deux côtés, court

- 20 48-T00228
T00228
- 25 48-86523



Porte-outil radial, deux côtés, court, HP-IC

- 20 48-T00228-HP IC 80 bar
T00228
- 25 48-86523-HP IC 80 bar



Porte-outil axial

- 25 48-T03024
T03024

Porte-outils fixes - Programme standard



Porte-outil axial, HP-IC

- 20 48-T03017-HP IC 80 bar
T03017



Porte-outil de tronçonnage, à droite

- 20 48-T00251
T00251
- 25 48-T00268
T00268, T00356



Porte-barre d'alésage

- $\phi 32$ 48-T10115
T10115



Porte-outil combiné

- $\phi 32$ 48-T13132 IC 80 bar
T13132
- $\phi 40$ 48-77999 IC 80 bar



Porte-barre d'alésage, deux côtés

- $\phi 25$ 48-T10117
T10117

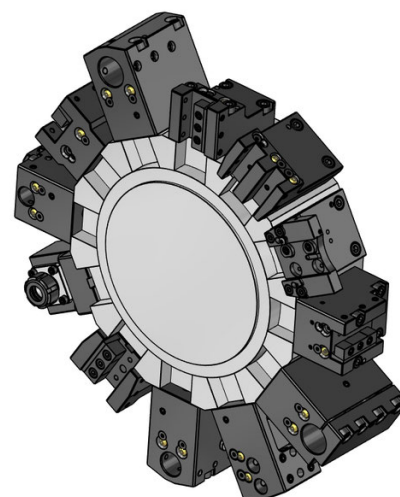
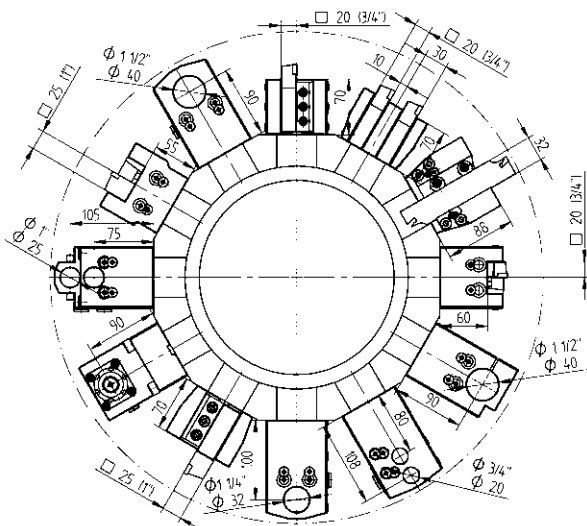

Porte-outils fixes - Programme élargi



Porte-outil radial, double, axe Y
 20 (3/4") 48-77726



Porte-outil radial, deux côtés, double, axe Y
 20 (3/4") 48-77727



Porte-outil axial, deux côtés
 20 48-79608



Porte-outil de tronçonnage, réglable
 SH 32 48-98891



Porte-outil de tronçonnage, réglable, HP-IC
 SH 32 48-102261R IC 80 bar
 SH 32 48-102261L IC 80 bar



Porte-barre d'alésage, avec fente
 Ø 32 48-82057
 Ø 40 48-82058



Porte-barre d'alésage, double, universel
 Ø 20 48-75406

Porte-outils fixes - Programme élargi



Porte-pince
 ER 25 48-107230 IC 80 bar
 107525000

ER 32 48-81031 IC 80 bar
 107532000



Adaptateur VDI, gauche
 VDI 30 48-77732



Adaptateur VDI, droite
 VDI 30 48-78687



Porte-barre d'alésage, ébauche
 48-80506

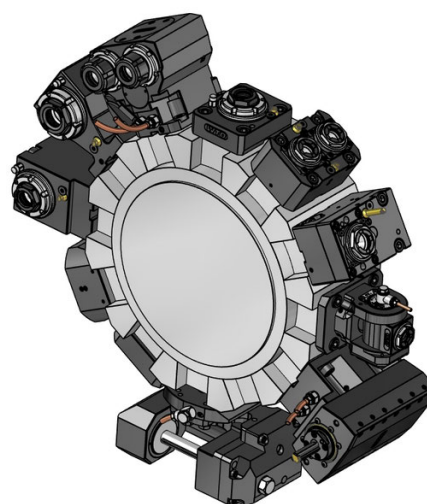
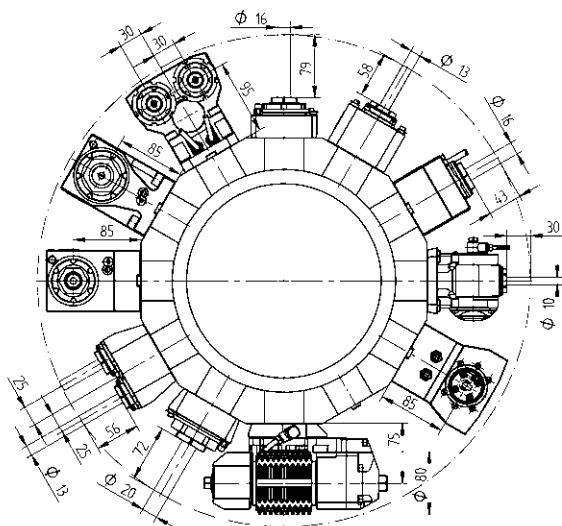

Porte-outils entraînés - QuickFlex®

Porte-outils entraînés - QuickFlex®



Porte-outil d'alésage et de fraisage radial (12000 tr/min)

- ER-25 QF** 420125012-40 T32433 1:1 EC
0067725000
- ER-25 QF** 420125013-40 1:1 IC 80 bar
0067725000
- ER-32 QF** QF32-DNE-MS40A-050-E-HS-A 1:1 EC
0067732000
- ER-32 QF** QF32-DNE-MS40A-067-I-HS-A 1:1 IC 100 bar
0067732000



Porte-outil d'alésage et de fraisage radial (12000 tr/min) - QF smart (UE, US, CA, JP)

- ER-32 QF** QF32-DNE-MS40A-067-I-HS-SB-A 1:1 IC 100 bar
0067732000
LI-F12-01



Porte-outil d'alésage et de fraisage radial (6000 tr/min, Heavy Duty)

- ER-25 QF** 420125010-40 T32274, T32450 1:1 EC
0067725000
- ER-25 QF** 420125011-40 T32287 1:1 IC 80 bar
0067725000
- ER-32 QF** 420132010-40 T32475, T32484 1:1 EC
0067732000
- ER-32 QF** 420132011-40 1:1 IC 80 bar
0067732000



Porte-outil d'alésage et de fraisage axial (12000 tr/min)

- ER-25 QF** 420525013-40 T32434 1:1 EC
0067725000
- ER-25 QF** 420525014-40 T32436 1:1 IC 80 bar
0067725000
- ER-32 QF** QF32-DNI-MS40A-085-E-HS-A 1:1 EC
0067732000
- ER-32 QF** QF32-DNI-MS40A-085-I-HS-A 1:1 IC 100 bar
0067732000



Porte-outil d'alésage et de fraisage axial (12000 tr/min) - QF smart (UE, US, CA, JP)

- ER-32 QF** QF32-DNI-MS40A-085-I-HS-SB-A 1:1 IC 100 bar
0067732000
LI-F12-01



Porte-outil d'alésage et de fraisage axial (6000 tr/min, Heavy Duty)

- ER-25 QF** 420525010-40 T32275, T32297 1:1 EC
0067725000
- ER-25 QF** 420525011-40 T32288, T32435 1:1 IC 80 bar
0067725000
- ER-32 QF** 420532010-40 T32476, T32485 1:1 EC
0067732000

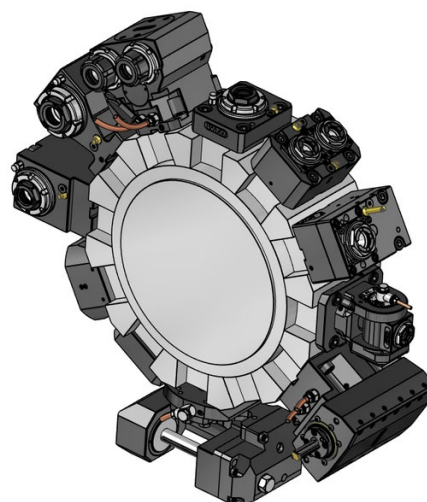
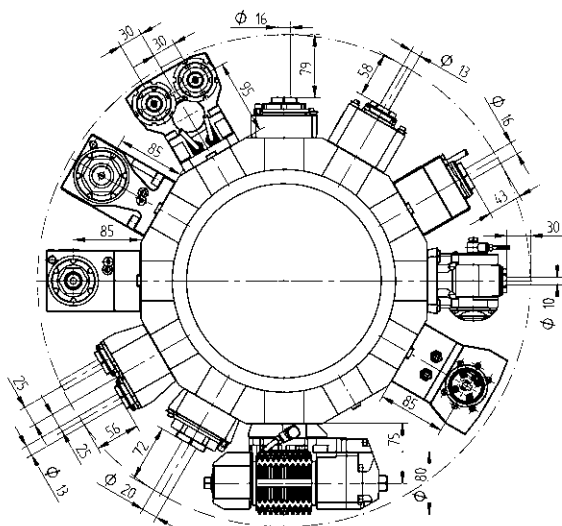

Porte-outils entrainés - QuickFlex®



Porte-outil d'alésage et de fraisage axial, deux côtés (12000 tr/min)

ER-25 QF	420525049-40 0067725000	1:1	EC
ER-32 QF	420532148-40 0067732000	1:1	EC



Porte-outil d'alésage et de fraisage axial pour pinces ER, deux côtés (6000 tr/min, Heavy Duty)

ER-25 QF	420525012-40 T32276, T32437 0067725000	1:1	EC
ER-32 QF	420532012-40 0067732000	1:1	EC

Porte-outils entrainés - Programme élargi

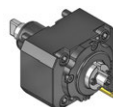

Porte-outil de fraisage radial avec arbre porte-fraise DIN 6358

Ø 16	410216010-40 00675000854	1:1	EC
Ø 22	410222016-40 T32280, T32486 00675000483	1:1	EC



Porte-outil d'alésage et de fraisage radial, décalé

ER 25	410116050-40 T32488 00675000932	1:1	EC
ER 25	410116057-40 00675000932	1:1	IC 80 bar
ER 20	410113060-40 00675000939	1:2	EC
ER 20	410113068-40 00675000939	1:2	IC 80 bar
ER 16	410410003-40 00675000937	1:3	EC
ER 16	410410004-40 00675000937	1:3	IC 80 bar
ER 25	410116051-40 00675000932	2:1	EC
ER 25	410116058-40 00675000932	2:1	IC 80 bar

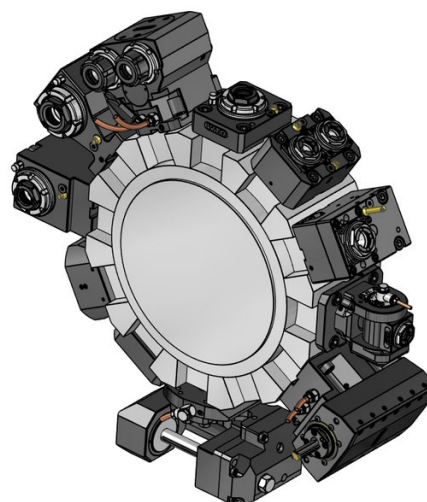
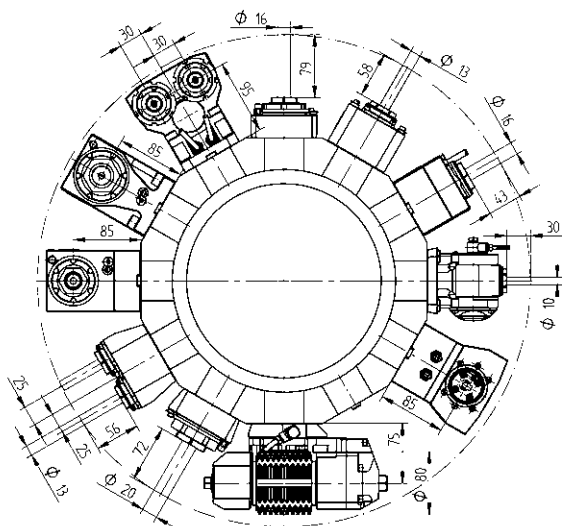

Porte-outils entraînés - Programme élargi



Porte-outil d'alésage et de fraisage radial, décalé (12000 tr/min)

ER 25	410116060-40	1:1	EC
	00675000932		
ER 25	410116059-40	1:1	IC 80 bar
	00675000932		



Porte-outil d'alésage et de fraisage axial

ER-20 QF	420520010-40	1:2	EC
	0067720001		
ER-20 QF	420520011-40	1:2	IC 80 bar
	0067720001		
ER 16	410810012-40	1:3	EC
	0067825001		
ER 16	410810013-40	1:3	IC 80 bar
	0067825001		
ER-32 QF	420532013-40	2:1	EC
	0067732000		
ER-32 QF	QF32-DNI-MS40A-085-I-T-A	2:1	IC 100 bar
	0067732000		



Porte-outil de fraisage axial avec arbre porte-fraise DIN 6358

Ø 16	410616013-40	1:1	EC
	00675000854		
Ø 22	410622030-40	1:1	EC
	00675000483		

Porte-outils entraînés - Programme élargi

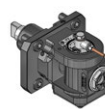

Porte-outil d'alésage et de fraisage à angle réglable

ER 16	411010008-40	1:1	EC
	00675000913		
ER 16	411010009-40	1:1	IC 80 bar
	00675000913		
ER 11	411007001-40	1:2	EC
	00675000914		
ER 11	411007002-40	1:2	IC 80 bar
	00675000914		



Unité de taillage de dentures

Type 16-1	411500017-40	1:1	EC
Type 16-1	411500018-40	2:1	EC
	00675000954		
	160016161 Ø 16		
	160022161 Ø 22		
	160027161 Ø 27		
	160015161 Ø 5/8"		
	160019161 Ø 3/4"		
	160025161 Ø 1"		
	160031161 Ø 1 1/4"		
	110587		

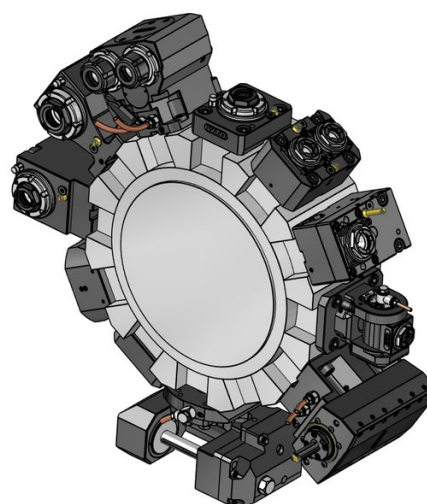
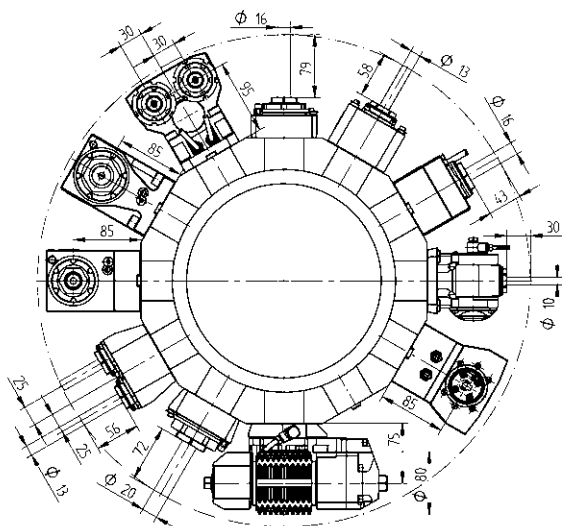

Porte-outils entraînés - Programme élargi

Porte-outils entraînés - Programme élargi



Porte-outil d'alésage et de fraisage radial, deux côtés

ER 20 413002015-40 1:1 EC
 00675000947

ER 20 413002018-40 1:1 IC 80 bar
 00675000947



Porte-outil d'alésage et de fraisage radial, double, axe Y

ER 20 413002014-40 1:1 EC
 00675000947

ER 20 413002017-40 1:1 IC 80 bar
 00675000947



Porte-outil d'alésage et de fraisage axial double, axe Y

ER 25 413502008-40 1:1 EC
 00675000915

ER 25 413502009-40 1:1 IC 80 bar
 00675000915

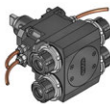

Porte-outil d'alésage et de fraisage axial double, deux côtés, axe Y

ER 25 413502007-40 1:1 EC
 00675000915



Unité de brochage intérieur et extérieur

Type 32 414532000-40 1:1 EC



Unité de brochage intérieur et extérieur

Type 52 414552002-40 1:1 EC

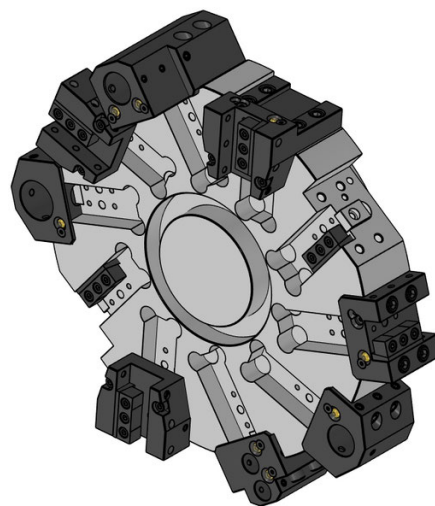
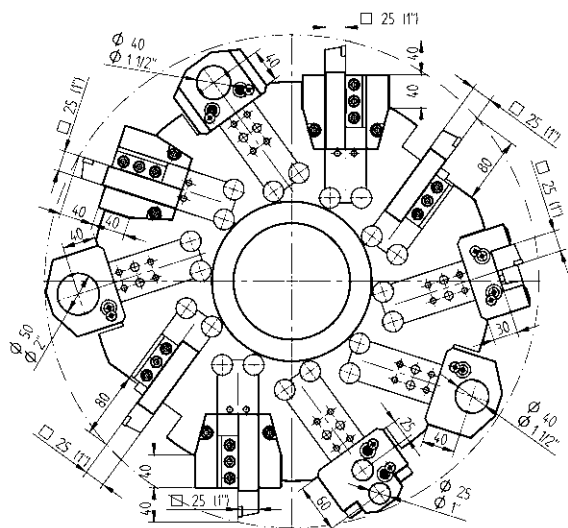

Porte-outils fixes - Programme standard

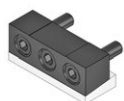

Cale de serrage

25(1") 48-B27036

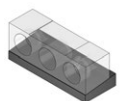

Cale

25 48-B27037



Porte-outil radial

25 48-T00074



Porte-outil axial

25 48-T00068



Porte-barre d'alésage

Ø 40 48-T10036
Ø 50 48-T10044



Porte-outil combiné

Ø 40 48-T13064 IC 80 bar
Ø 50 48-83292 IC 80 bar



Porte-outil combiné, allongé

Ø 40 48-T10038 IC 80 bar

Porte-outils fixes - Programme élargi



Butée

48-T17002



Porte-outil radial, HP-IC

25 48-T00074-HP IC 80 bar



Porte-outil axial, HP-IC

25 48-T00068-HP IC 80 bar



Porte-barre d'alésage, double

Ø 25 48-83452



Adaptateur VDI, gauche

VDI 30 48-83473



Adaptateur VDI, droite

VDI 30 48-49950

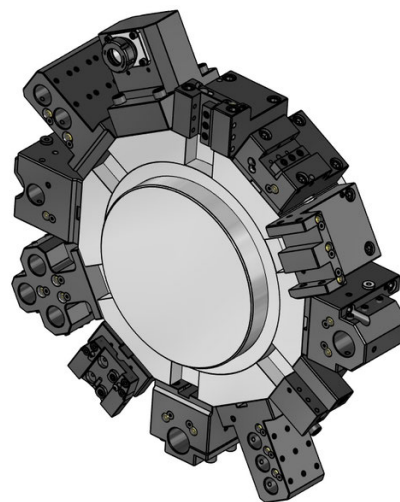
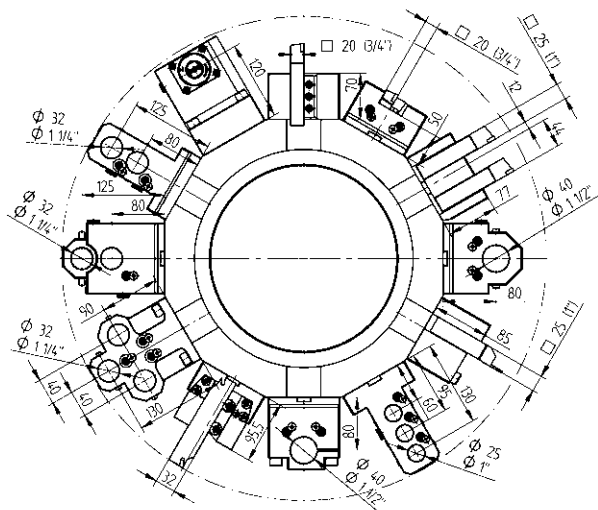

Porte-outils fixes - Programme standard



Porte-outil radial

- 20 48-T00187
T00187
- 25 48-T00186
T00186



Porte-outil radial, HP-IC

- 25 48-T00186-HP IC 80 bar
T00186



Porte-outil radial, deux côtés

- 20 48-T00185
T00185
- 25 48-T00184
T00184



Porte-outil radial, deux côtés, HP-IC

- 25 48-T00184-HP IC 80 bar
T00184



Porte-outil axial

- 20 48-T03006
T03006
- 25 48-T03005
T03005

Porte-outils fixes - Programme standard



Porte-outil axial, HP-IC

- 25 48-T03005-HP IC 80 bar
T03005



Porte-outil de tronçonnage, à droite

- 25 48-T00197
T00197



Porte-barre d'alésage, LF=80

- Ø 40 48-T10097
T10097
- Ø 50 48-T10098
T10098



Porte-barre d'alésage, LF=120

- Ø 40 48-T10113
T10113
- Ø 50 48-T10114
T10114



Porte-outil combiné, LF=80

- Ø 40 48-T13128 IC 80 bar
T13128
- Ø 50 48-T13139 IC 80 bar
T13139

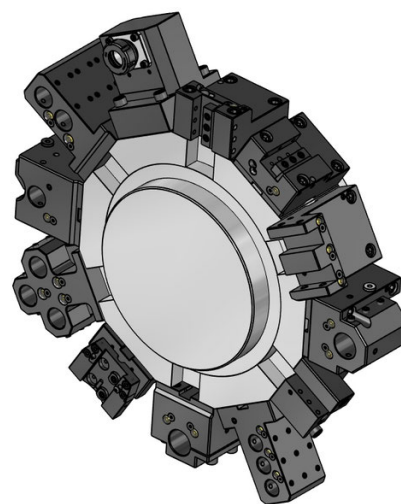
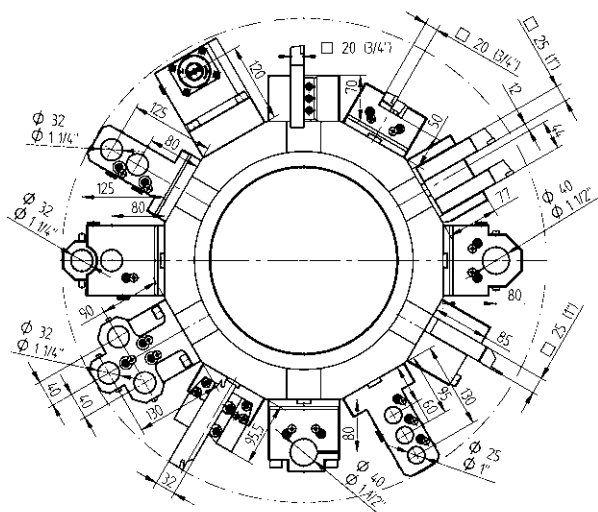

Porte-outils fixes - Programme standard



Porte-outil combiné, LF=120

- Ø 40 48-T13131 IC 80 bar
- T13131
- Ø 50 48-77902 IC 80 bar



Porte-barre d'alésage, deux côtés

- Ø 32 48-T10096
- T10096



Porte-outil combiné, deux côtés

- Ø 40 48-89027 IC 80 bar

Porte-outils fixes - Programme élargi



Porte-outil radial, à droite, long, HP-IC

- 25 48-T00385-HP IC 80 bar
- T00385



Porte-outil radial, gauche, long, HP-IC

- 25 48-T00387-HP IC 80 bar
- T00387

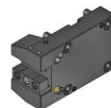

Porte-outil radial, court

- 25 48-79591



Porte-outil radial, allongé

- 25 48-T00236
- T00236



Porte-outil radial, double, axe Y

- 25(1") 48-71865
- T00206, T00210

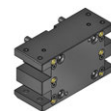

Porte-outil radial, deux côtés, double, axe Y

- 25(1") 48-71863
- T00253, T00258

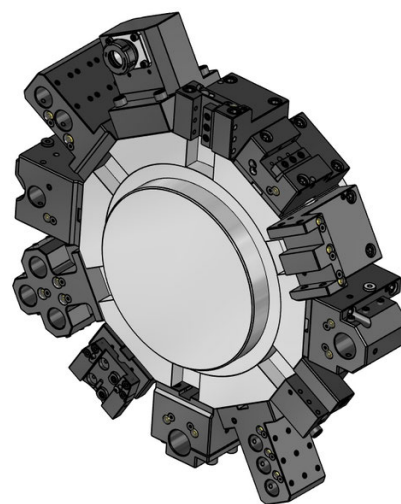
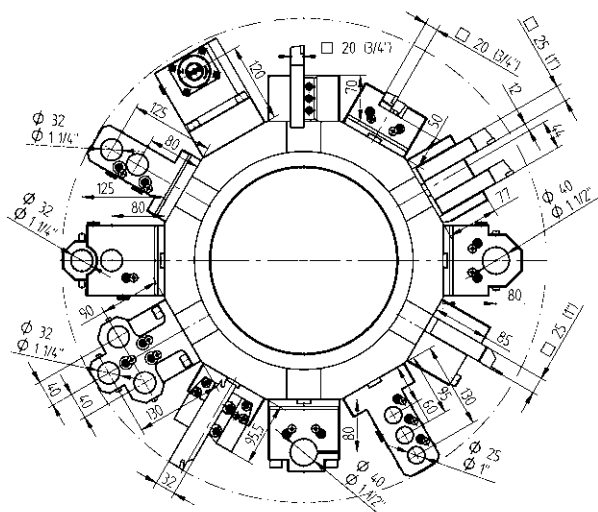

Porte-outils fixes - Programme élargi



Porte-outil axial, allongé

- 25** 48-T03019
T03019
- 32** 48-113046



Porte-outil axial, deux côtés

- 25** 48-78995



Porte-outil de tronçonnage, réglable

- SH 32** 48-98901



Porte-outil de tronçonnage, réglable, HP-IC

- SH 32** 48-102262R IC 80 bar
- SH 32** 48-102262L IC 80 bar



Porte-outil de tronçonnage, réglable, allongé

- SH 32** 48-77478



Porte-barre d'alésage, avec fente

- Ø 40** 48-T10136
T10136
- Ø 50** 48-T10137
T10137
- Ø 60** 48-70811

Porte-outils fixes - Programme élargi



Porte-barre d'alésage, triple, universel

- Ø 25** 48-T10104
T10104



Porte-barre d'alésage, double, deux côtés

- Ø 32** 48-71889



Porte-barre d'alésage, triple, deux côtés

- Ø 25** 48-71875



Porte-barre d'alésage, triple, deux côtés, axe Y

- Ø 32** 48-85932

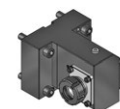

Porte-pince

- ER 32** 48-94564 IC 80 bar
107532000

- ER 40** 48-94566 IC 80 bar
107540000



Porte-pince, deux côtés

- ER 32** 48-94565 IC 80 bar
107532000

- ER 40** 48-94567 IC 80 bar
107540000

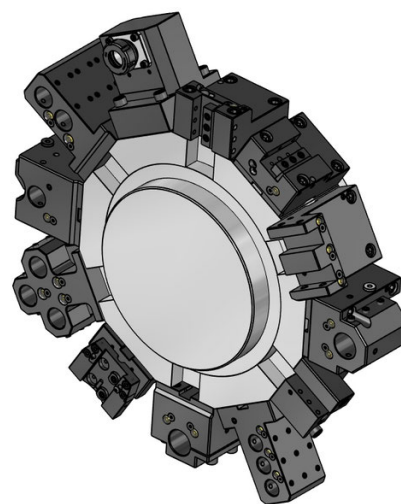
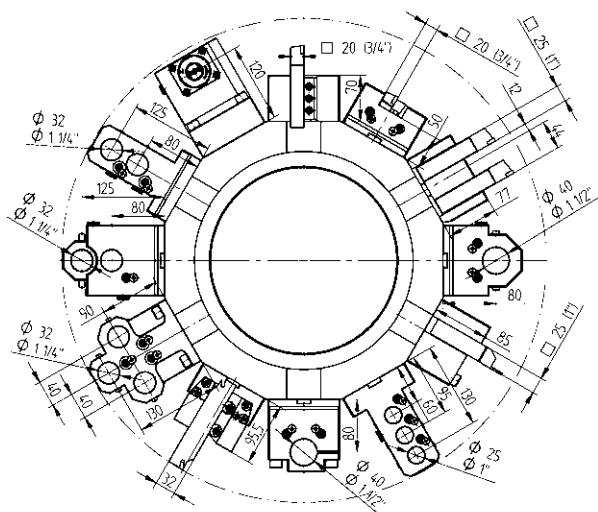

Porte-outils fixes - Programme élargi



Adaptateur VDI, gauche

VDI 30 48-77127
VDI 40 48-72984



Adaptateur VDI, droite

VDI 30 48-74796
VDI 40 48-77955



Porte-barre d'alésage, ébauche

48-81080

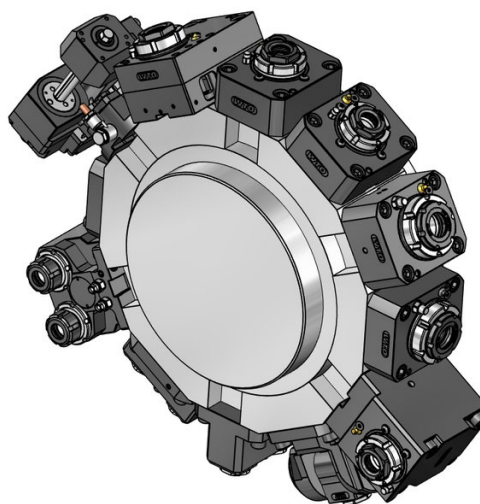
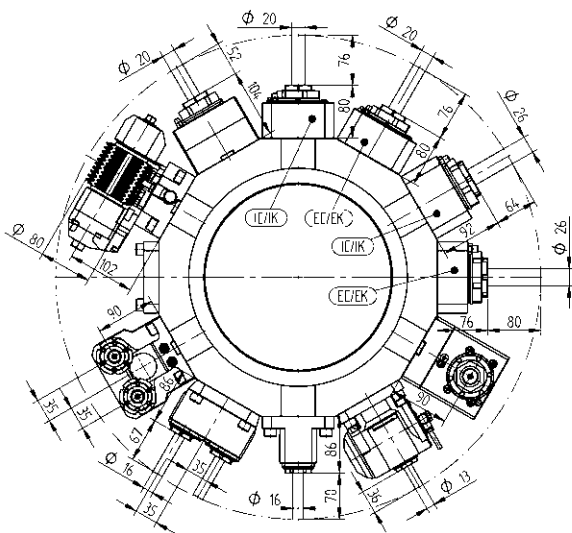

Porte-outils entrainés - QuickFlex®



Porte-outil d'alésage et de fraisage radial (12000 tr/min)

- ER-32 QF QF32-DNE-MS60A-072-E-HS-A 1:1 EC
0067732000
- ER-32 QF QF32-DNE-MS60A-072-I-HS-A 1:1 IC 100 bar
0067732000



Porte-outil d'alésage et de fraisage radial (12000 tr/min) - QF smart (UE, US, CA, JP)

- ER-32 QF QF32-DNE-MS60A-072-I-HS-SB-A 1:1 IC 100 bar
0067732000
- LI-F12-01



Porte-outil d'alésage et de fraisage radial (6000 tr/min, Heavy Duty)

- ER-32 QF 420132011-60 T32232, T32478 1:1 IC 80 bar
0067732000
- ER-40 QF 420140010-60 T32213 1:1 EC
0067740000
- ER-40 QF 420140011-60 T32234 1:1 IC 80 bar
0067740000



Porte-outil d'alésage et de fraisage axial (12000 tr/min)

- ER-32 QF QF32-DNI-MS60A-090-E-HS-A 1:1 EC
0067732000
- ER-32 QF QF32-DNI-MS60A-090-I-HS-A 1:1 IC 100 bar
0067732000

Porte-outils entrainés - QuickFlex®



Porte-outil d'alésage et de fraisage axial (12000 tr/min) - QF smart (UE, US, CA, JP)

- ER-32 QF QF32-DNI-MS60A-090-I-HS-SB-A 1:1 IC 100 bar
0067732000
- LI-F12-01



Porte-outil d'alésage et de fraisage axial (6000 tr/min, Heavy Duty)

- ER-40 QF 420540012-60 T32214 1:1 EC
0067740000
- ER-40 QF 420540013-60 T32235 1:1 IC 80 bar
0067740000



Porte-outil d'alésage et de fraisage axial pour pinces ER, deux côtés (10000 tr/min)

- ER-32 QF 420532041-60 1:1 EC
0067732000



Porte-outil d'alésage et de fraisage axial pour pinces ER, deux côtés (6000 tr/min, Heavy Duty)

- ER-32 QF 420532019-60 T32216 1:1 EC
0067732000
- ER-40 QF 420540016-60 T32248 1:1 EC
0067740000

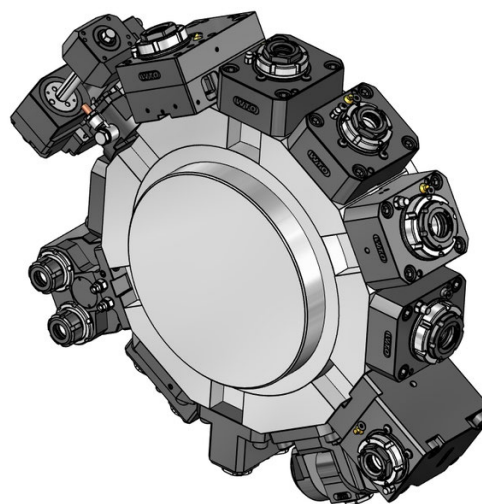
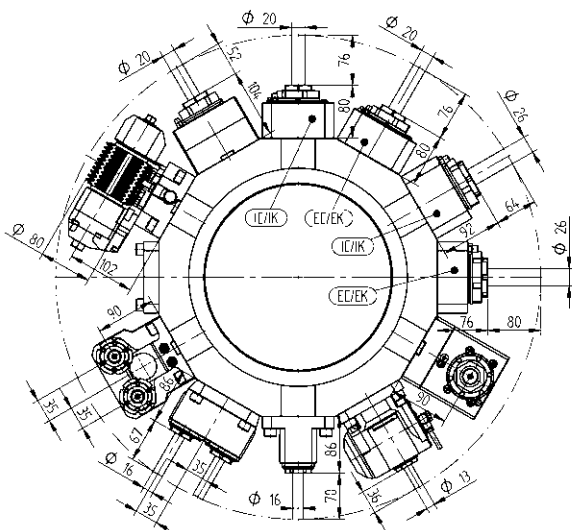

Porte-outils entraînés - Programme élargi



Porte-outil de fraisage radial avec arbre porte-fraise DIN 6358

Ø 16	410216000-60 00675000854	1:1	EC
Ø 22	410222007-60 T32268 00675000483	1:1	EC
Ø 27	410227008-60 00675000245	1:1	EC



Porte-outil d'alésage et de fraisage radial, décalé

ER-32 QF	420132019-60 0067732000	1:1	EC
ER-32 QF	420132020-60 0067732000	1:1	IC 80 bar
ER-25 QF	420125010-60 0067725001	1:2	EC
ER-25 QF	420125011-60 0067725001	1:2	IC 80 bar
ER-32 QF	420132021-60 0067732000	2:1	EC
ER-32 QF	420132022-60 0067732000	2:1	IC 80 bar

Porte-outils entraînés - Programme élargi



Porte-outil d'alésage et de fraisage axial

ER-25 QF	QF25-DNI-MS60A-090-E-S-A 0067725001	1:2	EC
ER-25 QF	QF25-DNI-MS60A-090-I-S-A 0067725001	1:2	IC 100 bar
ER-40 QF	420540014-60 0067740000	2:1	EC
ER-40 QF	420540015-60 0067740000	2:1	IC 80 bar

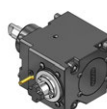

Porte-outil de fraisage axial avec arbre porte-fraise DIN 6358

Ø 22	M022-DNI-MS60A-090-E-T-A 00675000483	2:1	EC
Ø 27	M027-DNI-MS60A-090-E-T-A 00675000245	2:1	EC



Porte-outil d'alésage et de fraisage à angle réglable

ER 20	411013009-60 T32474 00675000928	1:1	EC
ER 20	411013010-60 00675000928	1:1	IC 80 bar
ER 16	411010001-60 00675000936	1:2	EC
ER 16	411010002-60 00675000936	1:2	IC 80 bar

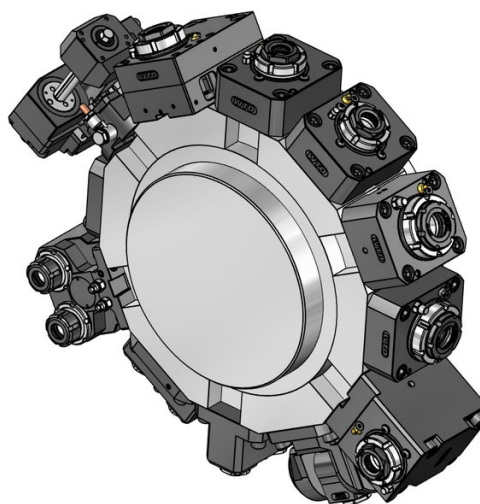
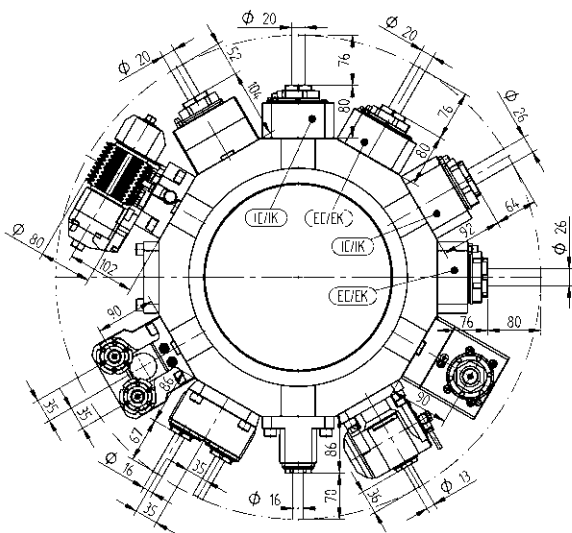

Porte-outils entraînés - Programme élargi

Porte-outils entraînés - Programme élargi



Porte-outil de fraisage pour fraise disque

- | | | | |
|------------------|--------------------|-----|----|
| Type 19-2 | 411500006-60 | 3:1 | EC |
| | 00675000855 | | |
| | 160022192 Ø 22 | | |
| | 160027192 Ø 27 | | |
| | 160032192 Ø 32 | | |
| | 160040192 Ø 40 | | |
| | 160023192 Ø 7/8" | | |
| | 160025192 Ø 1" | | |
| | 160031192 Ø 1 1/4" | | |
| | 160038192 Ø 1 1/2" | | |



Unité de taillage de dentures

- | | | | |
|------------------|--------------------|-----|----|
| Type 16-1 | 411500007-60 | 1:1 | EC |
| Type 16-1 | 411500008-60 | 2:1 | EC |
| | 00675000926 | | |
| | 160016161 Ø 16 | | |
| | 160022161 Ø 22 | | |
| | 160027161 Ø 27 | | |
| | 160015161 Ø 5/8" | | |
| | 160019161 Ø 3/4" | | |
| | 160025161 Ø 1" | | |
| | 160031161 Ø 1 1/4" | | |
| | 110587 | | |



Porte-outil d'alésage et de fraisage radial, deux côtés

- | | | | |
|--------------|--------------|-----|----|
| ER 25 | 413002001-60 | 1:1 | EC |
| | 00675000907 | | |



Porte-outil d'alésage et de fraisage radial, double, axe Y

- | | | | |
|--------------|--------------|-----|-----------|
| ER 25 | 413002000-60 | 1:1 | EC |
| | T32267 | | |
| | 00675000907 | | |
| ER 25 | 413002012-60 | 1:1 | IC 80 bar |
| | 00675000907 | | |

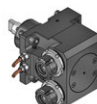

Porte-outil d'alésage et de fraisage axial double, axe Y

- | | | | |
|--------------|--------------|-----|-----------|
| ER 25 | 413502000-60 | 1:1 | EC |
| | T32264 | | |
| | 00675000915 | | |
| ER 25 | 413502002-60 | 1:1 | IC 80 bar |
| | 00675000915 | | |

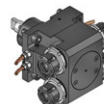

Porte-outil d'alésage et de fraisage axial double, deux côtés, axe Y

- | | | | |
|--------------|--------------|-----|----|
| ER 25 | 413502001-60 | 1:1 | EC |
| | 00675000915 | | |



Porte-outil d'alésage et de fraisage axial quadruple, deux côtés

- | | | | |
|--------------|--------------|-----|----|
| ER 20 | 413504000-60 | 1:1 | EC |
| | 00675000974 | | |

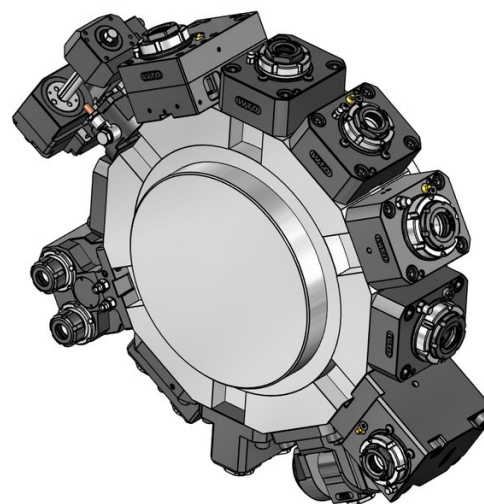
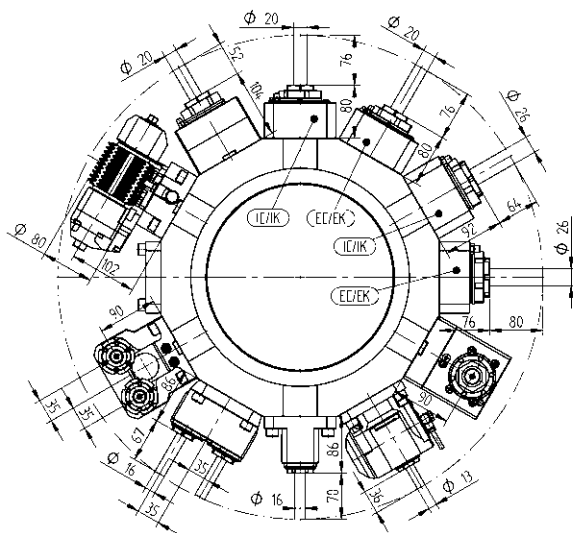

Porte-outils entraînés - Programme élargi



Unité de brochage intérieur et extérieur

Type 32	414532000-60	1:1	EC
Type 52	414552000-60	1:1	EC



Unité de Power Skiving

Hydra- lique	414920000-60	1:1	EC
-----------------	--------------	-----	----

 106445

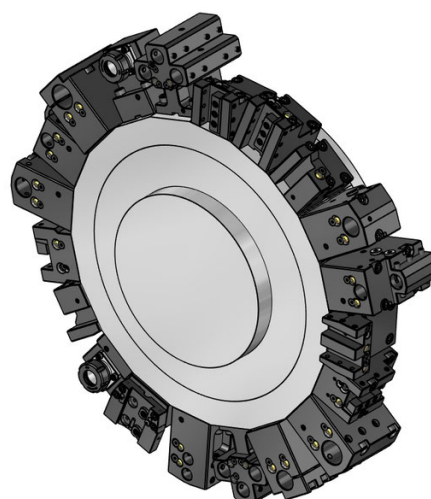
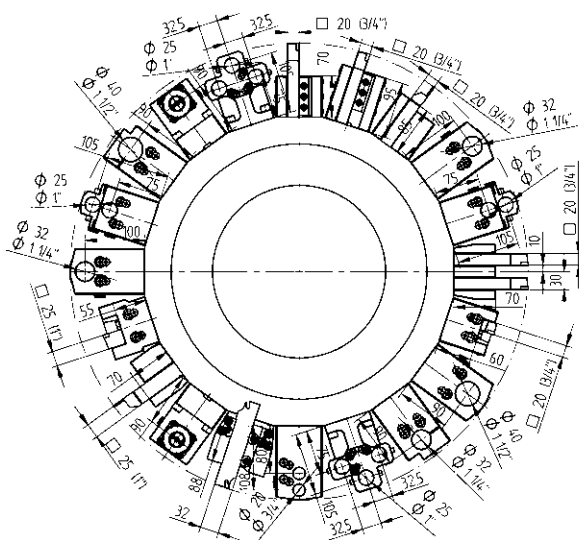

Porte-outils fixes - Programme standard



Porte-outil radial, court

- 20 48-T00224
T00224
- 25 48-T00267
T00267



Porte-outil radial, court, HP-IC

- 20 48-T00224-HP IC 80 bar
T00224
- 25 48-T00267-HP IC 80 bar
T00267



Porte-outil radial, long

- 20 48-T00225
T00225



Porte-outil radial, deux côtés, court

- 20 48-T00228
T00228
- 25 48-86523



Porte-outil radial, deux côtés, court, HP-IC

- 20 48-T00228-HP IC 80 bar
T00228
- 25 48-86523-HP IC 80 bar

Porte-outils fixes - Programme standard



Porte-outil radial, deux côtés, long

- 20 48-T00226
T00226



Porte-outil axial

- 25 48-T03024
T03024



Porte-outil axial, HP-IC

- 20 48-T03017-HP IC 80 bar
T03017



Porte-outil de tronçonnage, à droite

- 20 48-T00251
T00251
- 25 48-T00268
T00268, T00356



Porte-barre d'alésage

- Ø 32 48-T10115
T10115



Porte-outil combiné

- Ø 32 48-T13132 IC 80 bar
T13132
- Ø 40 48-77999 IC 80 bar

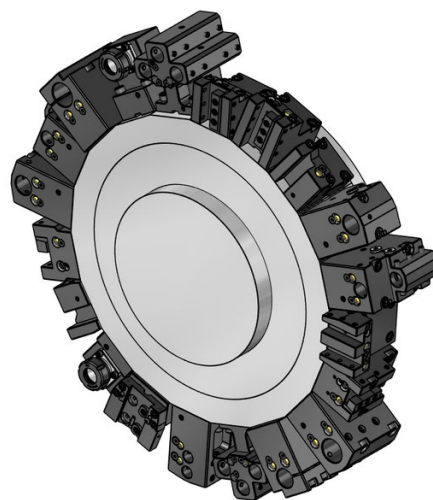
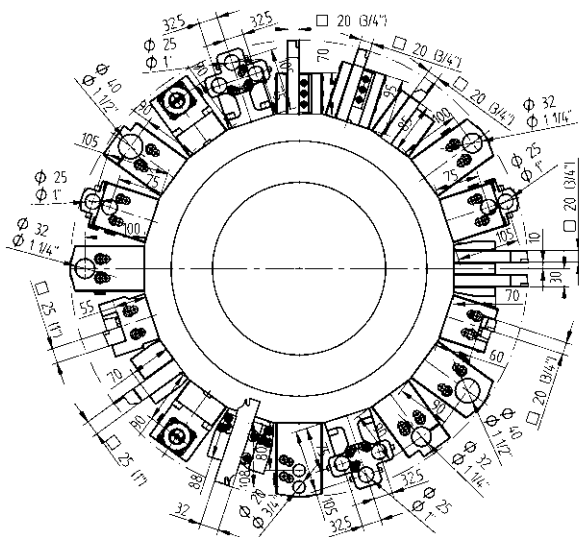

Porte-outils fixes - Programme standard

Porte-outils fixes - Programme élargi



Ø 25

Porte-barre d'alésage, deux côtés

48-T10117
T10117



20 (3/4")

Porte-outil radial, double, axe Y

48-77726



20 (3/4")

Porte-outil radial, deux côtés, double, axe Y

48-77727



20

Porte-outil axial, deux côtés

48-79608



SH 32

Porte-outil de tronçonnage, réglable

48-98891



SH 32

Porte-outil de tronçonnage, réglable, HP-IC

48-102261R

IC 80 bar

48-102261L

IC 80 bar



Ø 32

Porte-barre d'alésage, avec fente

Ø 40

48-82057

48-82058



Ø 20

Porte-barre d'alésage, double, universel

48-75406

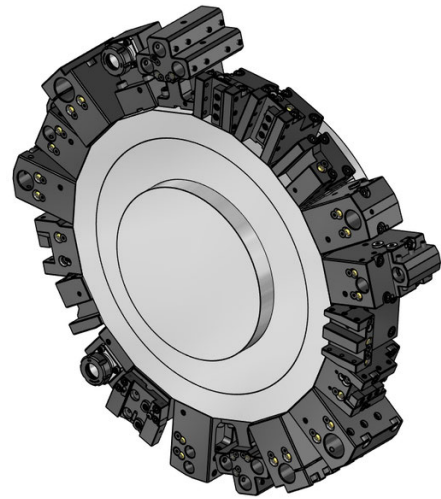
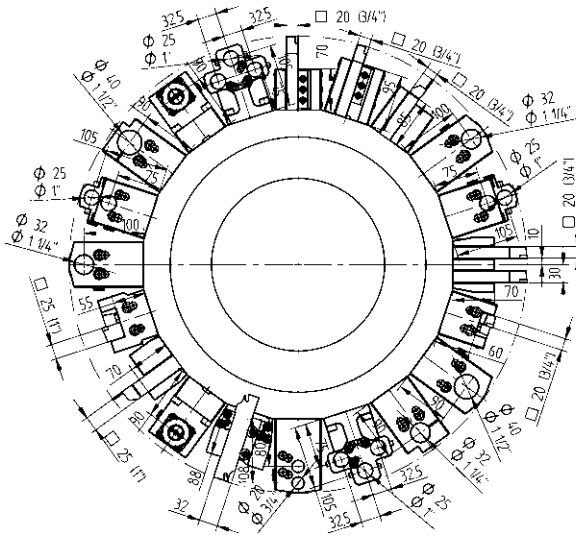

Porte-outils fixes - Programme élargi

Porte-outils fixes - Programme élargi



Ø 20

Porte-barre d'alésage, double, deux côtés

48-75404



48-80506

Porte-barre d'alésage, ébauche



Ø 25

Porte-outil combiné, deux côtés, triple, axe Y

48-85908

IC 80 bar



ER 25

Porte-pince

48-107230

IC 80 bar

107525000

ER 32

48-81031

IC 80 bar

107532000



ER 25

Porte-pince, deux côtés

48-107227

IC 80 bar

107525000

ER 32

48-80509

IC 80 bar

107532000



VDI 30

Adaptateur VDI, gauche

48-77732



VDI 30

Adaptateur VDI, droite

48-78687

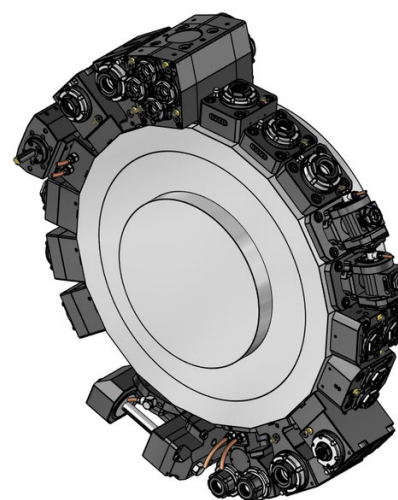
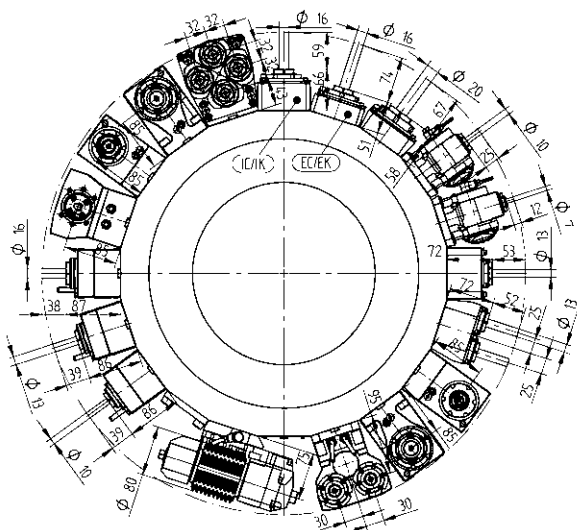

Porte-outils entraînés - QuickFlex®



Porte-outil d'alésage et de fraisage radial (12000 tr/min)

ER-25 QF	420125012-40 T32433	1:1	EC
	0067725000		
ER-25 QF	420125013-40	1:1	IC 80 bar
	0067725000		
ER-32 QF	QF32-DNE-MS40A-050-E-HS-A	1:1	EC
	0067732000		
ER-32 QF	QF32-DNE-MS40A-067-I-HS-A	1:1	IC 100 bar
	0067732000		



Porte-outil d'alésage et de fraisage radial (12000 tr/min) - QF smart (UE, US, CA, JP)

ER-32 QF	QF32-DNE-MS40A-067-I-HS-SB-A	1:1	IC 100 bar
	0067732000		
	LI-F12-01		



Porte-outil d'alésage et de fraisage radial (6000 tr/min, Heavy Duty)

ER-25 QF	420125010-40 T32274, T32450	1:1	EC
	0067725000		
ER-25 QF	420125011-40 T32287	1:1	IC 80 bar
	0067725000		
ER-32 QF	420132010-40 T32475, T32484	1:1	EC
	0067732000		
ER-32 QF	420132011-40	1:1	IC 80 bar
	0067732000		

Porte-outils entraînés - QuickFlex®



Porte-outil d'alésage et de fraisage axial (12000 tr/min)

ER-25 QF	420525013-40 T32434	1:1	EC
	0067725000		
ER-25 QF	420525014-40 T32436	1:1	IC 80 bar
	0067725000		
ER-32 QF	QF32-DNI-MS40A-085-E-HS-A	1:1	EC
	0067732000		
ER-32 QF	QF32-DNI-MS40A-085-I-HS-A	1:1	IC 100 bar
	0067732000		



Porte-outil d'alésage et de fraisage axial (12000 tr/min) - QF smart (UE, US, CA, JP)

ER-32 QF	QF32-DNI-MS40A-085-I-HS-SB-A	1:1	IC 100 bar
	0067732000		
	LI-F12-01		



Porte-outil d'alésage et de fraisage axial (6000 tr/min, Heavy Duty)

ER-25 QF	420525010-40 T32275, T32297	1:1	EC
	0067725000		
ER-25 QF	420525011-40 T32288, T32435	1:1	IC 80 bar
	0067725000		
ER-32 QF	420532010-40 T32476, T32485	1:1	EC
	0067732000		

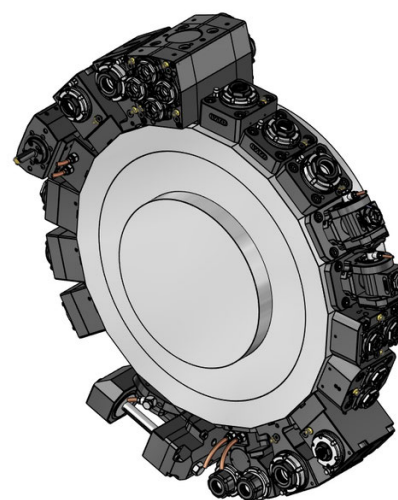
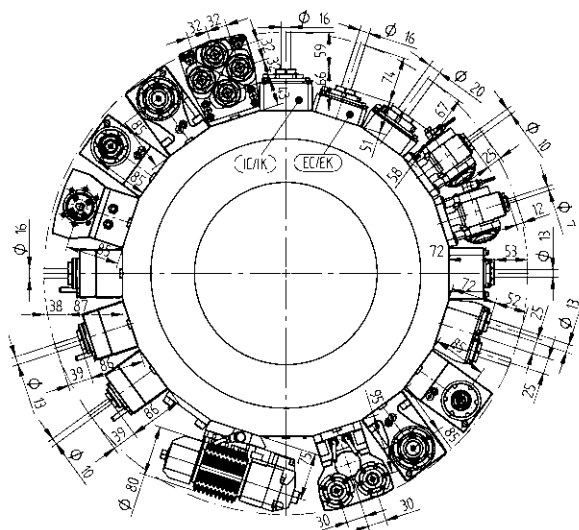

Porte-outils entrainés - QuickFlex®



Porte-outil d'alésage et de fraisage axial, deux côtés (12000 tr/min)

ER-25 QF	420525049-40 0067725000	1:1	EC
ER-32 QF	420532148-40 0067732000	1:1	EC



Porte-outil d'alésage et de fraisage axial pour pinces ER, deux côtés (6000 tr/min, Heavy Duty)

ER-25 QF	420525012-40 T32276, T32437 0067725000	1:1	EC
ER-32 QF	420532012-40 0067732000	1:1	EC

Porte-outils entrainés - Programme élargi

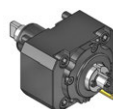

Porte-outil de fraisage radial avec arbre porte-fraise DIN 6358

Ø 16	410216010-40 00675000854	1:1	EC
Ø 22	410222016-40 T32280, T32486 00675000483	1:1	EC



Porte-outil d'alésage et de fraisage radial, décalé

ER 25	410116050-40 T32488 00675000932	1:1	EC
ER 25	410116057-40 00675000932	1:1	IC 80 bar
ER 20	410113060-40 00675000939	1:2	EC
ER 20	410113068-40 00675000939	1:2	IC 80 bar
ER 16	410410003-40 00675000937	1:3	EC
ER 16	410410004-40 00675000937	1:3	IC 80 bar
ER 25	410116051-40 00675000932	2:1	EC
ER 25	410116058-40 00675000932	2:1	IC 80 bar

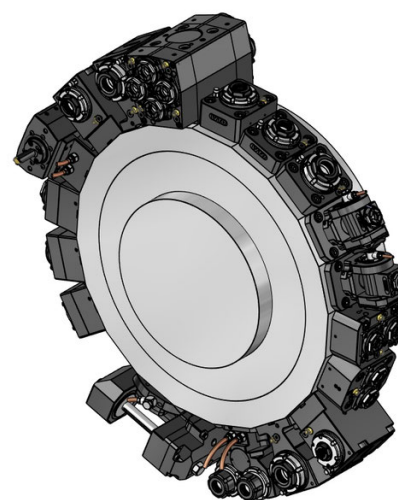
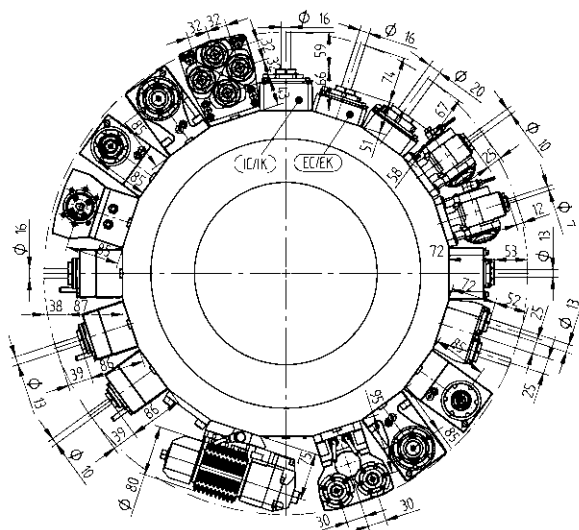

Porte-outils entraînés - Programme élargi



Porte-outil d'alésage et de fraisage radial, décalé (12000 tr/min)

ER 25	410116060-40	1:1	EC
	00675000932		
ER 25	410116059-40	1:1	IC 80 bar
	00675000932		



Porte-outil d'alésage et de fraisage axial

ER-20 QF	420520010-40	1:2	EC
	0067720001		
ER-20 QF	420520011-40	1:2	IC 80 bar
	0067720001		
ER 16	410810012-40	1:3	EC
	0067825001		
ER 16	410810013-40	1:3	IC 80 bar
	0067825001		
ER-32 QF	420532013-40	2:1	EC
	0067732000		
ER-32 QF	QF32-DNI-MS40A-085-I-T-A	2:1	IC 100 bar
	0067732000		



Porte-outil de fraisage axial avec arbre porte-fraise DIN 6358

Ø 16	410616013-40	1:1	EC
	00675000854		
Ø 22	410622030-40	1:1	EC
	00675000483		

Porte-outils entraînés - Programme élargi



Porte-outil d'alésage et de fraisage axial en retrait

ER 25	410516153-40	1:1	EC
	00675000801		
ER 25	410516154-40	1:1	IC 80 bar
	00675000801		



Porte-outil d'alésage et de fraisage à angle réglable

ER 16	411010008-40	1:1	EC
	00675000913		
ER 16	411010009-40	1:1	IC 80 bar
	00675000913		
ER 11	411007001-40	1:2	EC
	00675000914		
ER 11	411007002-40	1:2	IC 80 bar
	00675000914		

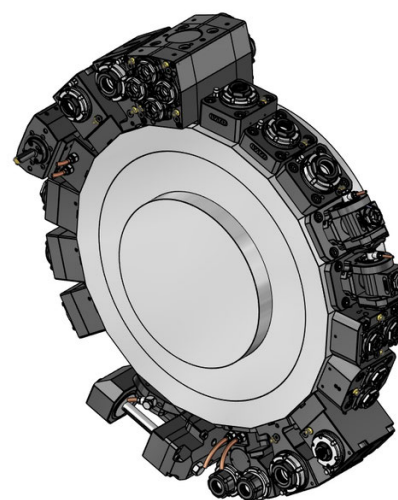
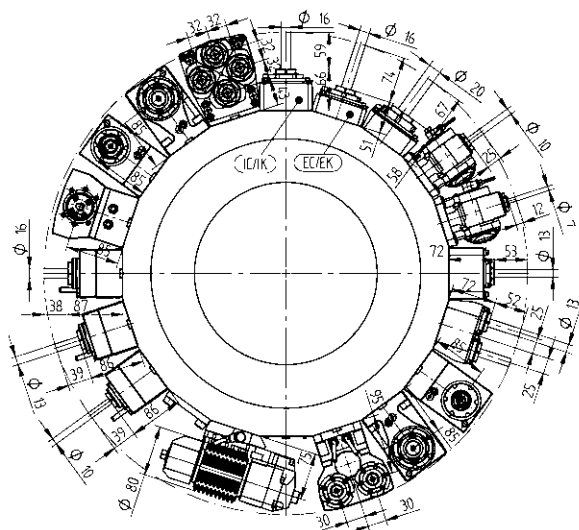

Porte-outils entraînés - Programme élargi



Unité de taillage de dentures

Type 16-1	411500017-40	1:1	EC
Type 16-1	411500018-40	2:1	EC
	00675000954		
	160016161 Ø 16		
	160022161 Ø 22		
	160027161 Ø 27		
	160015161 Ø 5/8"		
	160019161 Ø 3/4"		
	160025161 Ø 1"		
	160031161 Ø 1 1/4"		
	110587		



Porte-outil d'alésage et de fraisage radial, deux côtés

ER 20	413002015-40	1:1	EC
	00675000947		
ER 20	413002018-40	1:1	IC 80 bar
	00675000947		



Porte-outil d'alésage et de fraisage radial, double, axe Y

ER 20	413002014-40	1:1	EC
	00675000947		
ER 20	413002017-40	1:1	IC 80 bar
	00675000947		

Porte-outils entraînés - Programme élargi

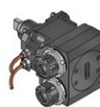

Porte-outil d'alésage et de fraisage axial double, axe Y

ER 25	413502008-40	1:1	EC
	00675000915		
ER 25	413502009-40	1:1	IC 80 bar
	00675000915		



Porte-outil d'alésage et de fraisage axial double, deux côtés, axe Y

ER 25	413502007-40	1:1	EC
	00675000915		



Porte-outil d'alésage et de fraisage axial quadruple

ER 20	413504001-40	1:1	EC
	00675000947		

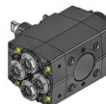

Porte-outil d'alésage et de fraisage axial quadruple, deux côtés

ER 20	413504000-40	1:1	EC
	00675000947		



Unité de brochage intérieur et extérieur

Type 32	414532000-40	1:1	EC
---------	--------------	-----	----



Unité de brochage intérieur et extérieur

Type 52	414552002-40	1:1	EC
---------	--------------	-----	----

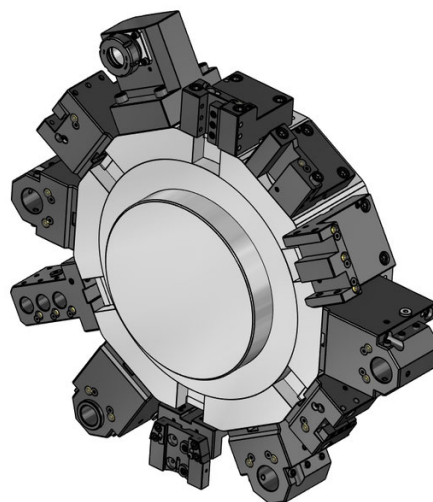
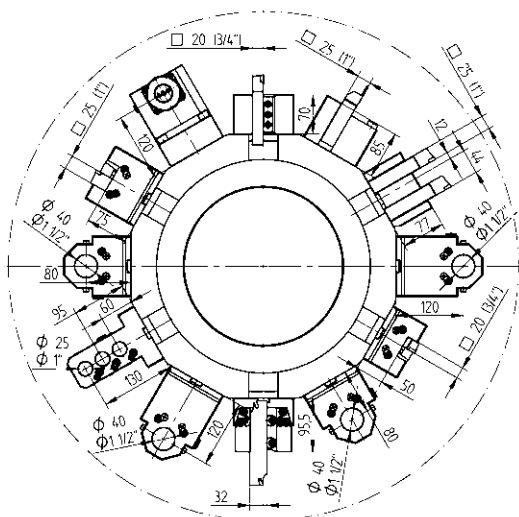

Porte-outils fixes - Programme standard



Porte-outil radial

- 20 48-T00187
T00187
- 25 48-T00186
T00186



Porte-outil radial, HP-IC

- 25 48-T00186-HP
T00186 IC 80 bar



Porte-outil axial

- 20 48-T03006
T03006
- 25 48-T03005
T03005



Porte-outil axial, HP-IC

- 25 48-T03005-HP
T03005 IC 80 bar



Porte-outil de tronçonnage, à droite

- 25 48-T00197
T00197

Porte-outils fixes - Programme standard



Porte-barre d'alésage, LF=80

- Ø 40 48-T10097
T10097
- Ø 50 48-T10098
T10098



Porte-barre d'alésage, LF=120

- Ø 40 48-T10113
T10113
- Ø 50 48-T10114
T10114



Porte-outil combiné, LF=80

- Ø 40 48-T13128
T13128 IC 80 bar
- Ø 50 48-T13139
T13139 IC 80 bar



Porte-outil combiné, LF=120

- Ø 40 48-T13131
T13131 IC 80 bar
- Ø 50 48-77902
IC 80 bar

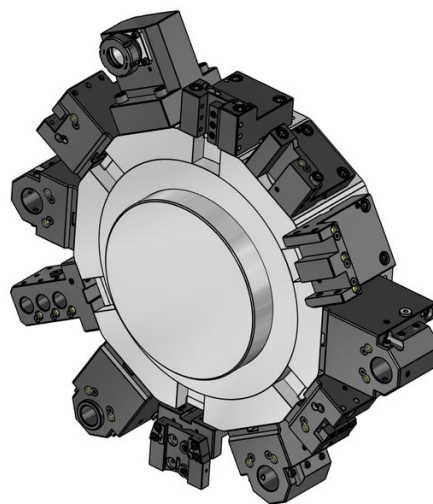
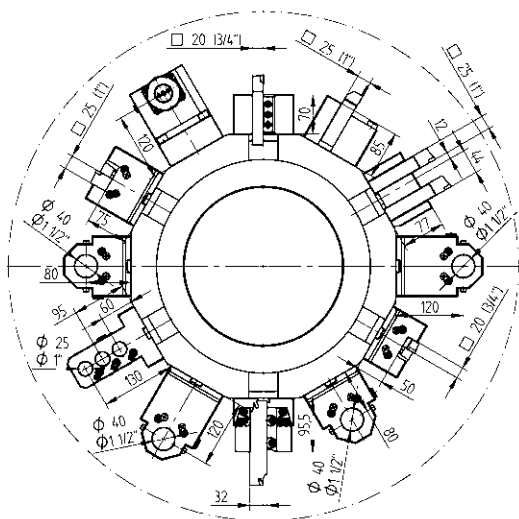



Porte-outils fixes - Programme élargi

Porte-outils fixes - Programme élargi

- 

Porte-outil radial, à droite, long, HP-IC
25 48-T00385-HP IC 80 bar
 T00385
- 

Porte-outil radial, gauche, long, HP-IC
25 48-T00387-HP IC 80 bar
 T00387
- 

Porte-outil radial, court
25 48-79591
- 

Porte-outil radial, allongé
25 48-T00236
 T00236
- 

Porte-outil radial, double, axe Y
25(1") 48-71865
 T00206, T00210
- 

Porte-outil axial, allongé
25 48-T03019
 T03019
32 48-113046

- 

Porte-outil de tronçonnage, réglable
SH 32 48-98901
- 

Porte-outil de tronçonnage, réglable, HP-IC
SH 32 48-102262R IC 80 bar
SH 32 48-102262L IC 80 bar
- 

Porte-outil de tronçonnage, réglable, allongé
SH 32 48-77478
- 

Porte-barre d'alésage, allongé
Ø 40 48-T13163
 T13163
Ø 50 48-T13161
 T13161
- 

Porte-barre d'alésage, avec fente
Ø 40 48-T10136
 T10136
Ø 50 48-T10137
 T10137
Ø 60 48-70811
- 

Porte-barre d'alésage, triple, universel
Ø 25 48-T10104
 T10104

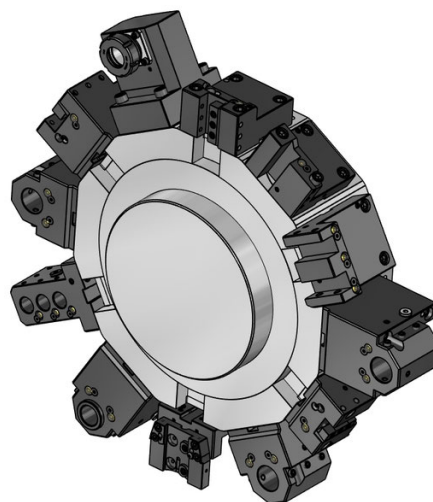
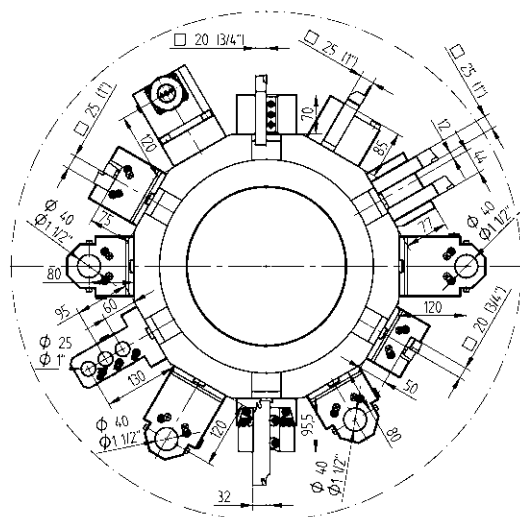

Porte-outils fixes - Programme élargi

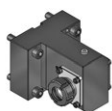

Porte-pince

- | | | |
|--------------|-----------|-----------|
| ER 32 | 48-94564 | IC 80 bar |
| | 107532000 | |
| ER 40 | 48-94566 | IC 80 bar |
| | 107540000 | |



Adaptateur VDI, gauche

- | | |
|---------------|----------|
| VDI 30 | 48-77127 |
| VDI 40 | 48-72984 |



Adaptateur VDI, droite

- | | |
|---------------|----------|
| VDI 30 | 48-74796 |
| VDI 40 | 48-77955 |



Porte-barre d'alésage, ébauche

48-81080

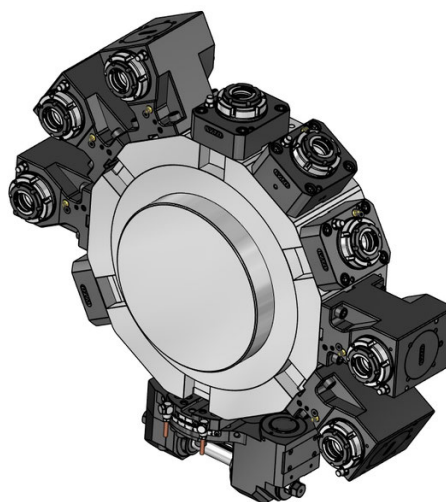
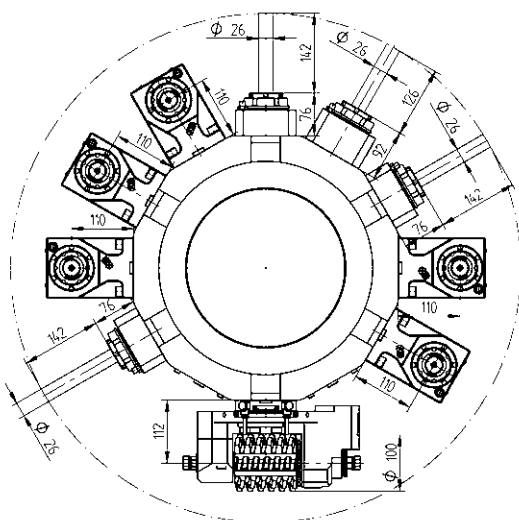

Porte-outils entraînés - QuickFlex®



Porte-outil d'alésage et de fraisage radial (12000 tr/min)

- ER-32 QF** QF32-DNE-MS60A-072-E-HS-A 1:1 EC
0067732000
- ER-32 QF** QF32-DNE-MS60A-072-I-HS-A 1:1 IC 100 bar
0067732000



Porte-outil d'alésage et de fraisage radial (12000 tr/min) - QF smart (UE, US, CA, JP)

- ER-32 QF** QF32-DNE-MS60A-072-I-HS-SB-A 1:1 IC 100 bar
0067732000
- LI-F12-01



Porte-outil d'alésage et de fraisage radial (6000 tr/min, Heavy Duty)

- ER-32 QF** 420132011-60 T32232, T32478 1:1 IC 80 bar
0067732000
- ER-40 QF** 420140010-60 T32213 1:1 EC
0067740000
- ER-40 QF** 420140011-60 T32234 1:1 IC 80 bar
0067740000



Porte-outil d'alésage et de fraisage radial (uniquement pour NLX 4000 version High Torque)

- ER-40 QF** 420140014-60 T32544 1:1 EC
0067740000
- ER-40 QF** 420140015-60 1:1 IC 80 bar
0067740000

Porte-outils entraînés - QuickFlex®



Porte-outil d'alésage et de fraisage axial (12000 tr/min)

- ER-32 QF** QF32-DNI-MS60A-090-E-HS-A 1:1 EC
0067732000
- ER-32 QF** QF32-DNI-MS60A-090-I-HS-A 1:1 IC 100 bar
0067732000



Porte-outil d'alésage et de fraisage axial (12000 tr/min) - QF smart (UE, US, CA, JP)

- ER-32 QF** QF32-DNI-MS60A-090-I-HS-SB-A 1:1 IC 100 bar
0067732000
- LI-F12-01



Porte-outil d'alésage et de fraisage axial (6000 tr/min, Heavy Duty)

- ER-40 QF** 420540012-60 T32214 1:1 EC
0067740000
- ER-40 QF** 420540013-60 T32235 1:1 IC 80 bar
0067740000



Porte-outil d'alésage et de fraisage axial (uniquement pour NLX 4000 version High Torque)

- ER-40 QF** 420540017-60 T32546 1:1 EC
0067740000
- ER-40 QF** 420540018-60 1:1 IC 80 bar
0067740000

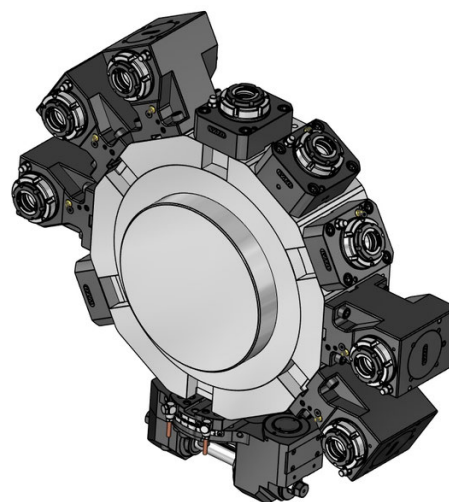
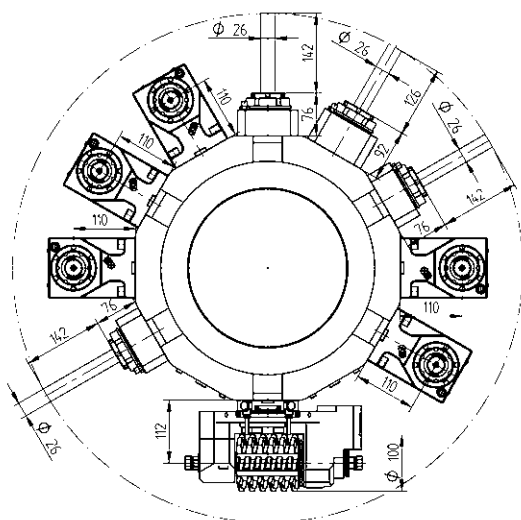

Porte-outils entraînés - Programme élargi



Porte-outil de fraisage radial avec arbre porte-fraise DIN 6358

Ø 16	410216000-60 00675000854	1:1	EC
Ø 22	410222007-60 T32268 00675000483	1:1	EC
Ø 27	410227008-60 00675000245	1:1	EC



Porte-outil d'alésage et de fraisage radial, décalé

ER-32 QF	420132019-60 0067732000	1:1	EC
ER-32 QF	420132020-60 0067732000	1:1	IC 80 bar
ER-25 QF	420125010-60 0067725001	1:2	EC
ER-25 QF	420125011-60 0067725001	1:2	IC 80 bar
ER-32 QF	420132021-60 0067732000	2:1	EC
ER-32 QF	420132022-60 0067732000	2:1	IC 80 bar



Porte-outil d'alésage et de fraisage axial

ER-25 QF	QF25-DNI-MS60A-090-E-S-A 0067725001	1:2	EC
ER-25 QF	QF25-DNI-MS60A-090-I-S-A 0067725001	1:2	IC 100 bar
ER-40 QF	420540014-60 0067740000	2:1	EC
ER-40 QF	420540015-60 0067740000	2:1	IC 80 bar

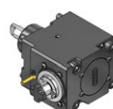

Porte-outil de fraisage axial avec arbre porte-fraise DIN 6358

Ø 22	M022-DNI-MS60A-090-E-T-A 00675000483	2:1	EC
Ø 27	M027-DNI-MS60A-090-E-T-A 00675000245	2:1	EC



Porte-outil d'alésage et de fraisage à angle réglable

ER 20	411013009-60 T32474 00675000928	1:1	EC
ER 20	411013010-60 00675000928	1:1	IC 80 bar
ER 16	411010001-60 00675000936	1:2	EC
ER 16	411010002-60 00675000936	1:2	IC 80 bar

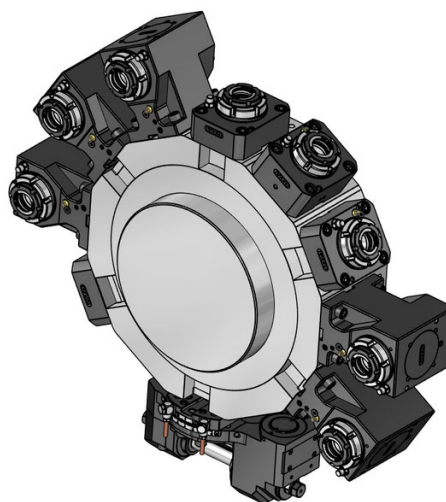
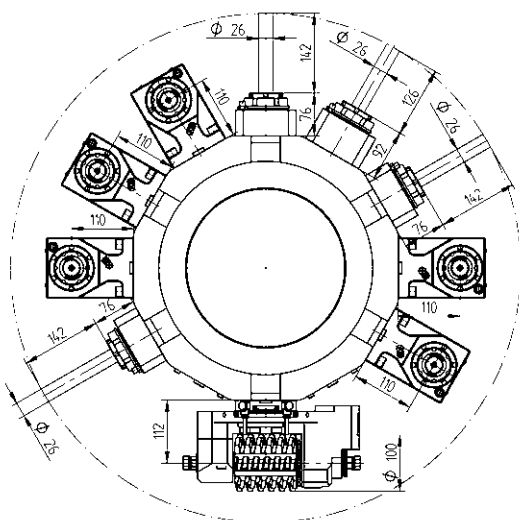

Porte-outils entraînés - Programme élargi

Porte-outils entraînés - Programme élargi



Porte-outil de fraisage pour fraise disque

Type 19-2	411500006-60	3:1	EC
	00675000855		
	160022192 Ø 22		
	160027192 Ø 27		
	160032192 Ø 32		
	160040192 Ø 40		
	160023192 Ø 7/8"		
	160025192 Ø 1"		
	160031192 Ø 1 1/4"		
	160038192 Ø 1 1/2"		



Unité de taillage de dentures (uniquement pour NLX 4000 version High Torque)

Type C5-1	410900003-60	2:1	EC
	00675001008		
	160022C51 Ø 22		
	160027C51 Ø 27		
	160032C51 Ø 32		
	160019C51 Ø 3/4"		
	160025C51 Ø 1"		
	160031C51 Ø 1 1/4"		
	110587		



Unité de taillage de dentures

Type 16-1	411500007-60	1:1	EC
Type 16-1	411500008-60	2:1	EC
	00675000926		
	160016161 Ø 16		
	160022161 Ø 22		
	160027161 Ø 27		
	160015161 Ø 5/8"		
	160019161 Ø 3/4"		
	160025161 Ø 1"		
	160031161 Ø 1 1/4"		
	110587		



Porte-outil d'alésage et de fraisage radial, double, axe Y

ER 25	413002000-60	1:1	EC
	T32267		
	00675000907		
ER 25	413002012-60	1:1	IC 80 bar
	00675000907		

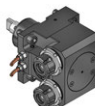

Porte-outil d'alésage et de fraisage axial double, axe Y

ER 25	413502000-60	1:1	EC
	T32264		
	00675000915		
ER 25	413502002-60	1:1	IC 80 bar
	00675000915		

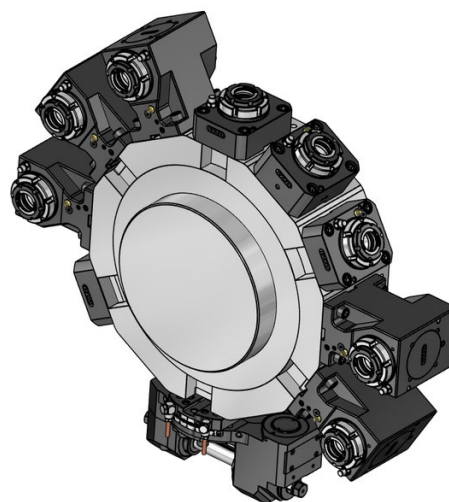
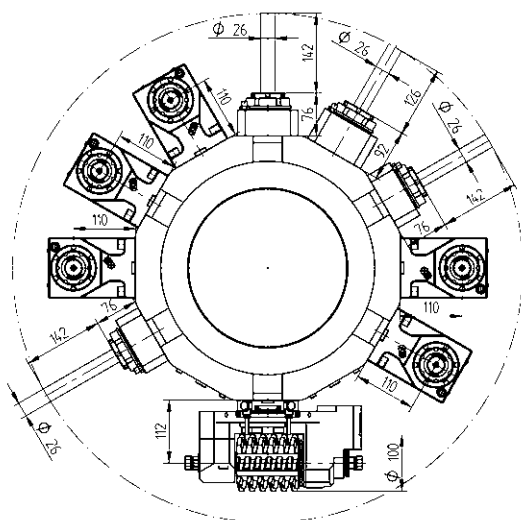

Porte-outils entraînés - Programme élargi



Unité de brochage intérieur et extérieur

Type 32	414532000-60	1:1	EC
Type 52	414552000-60	1:1	EC

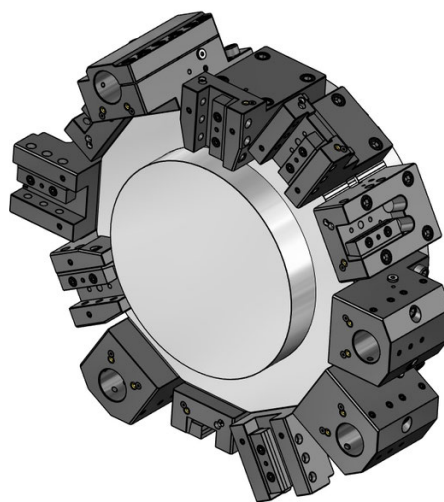
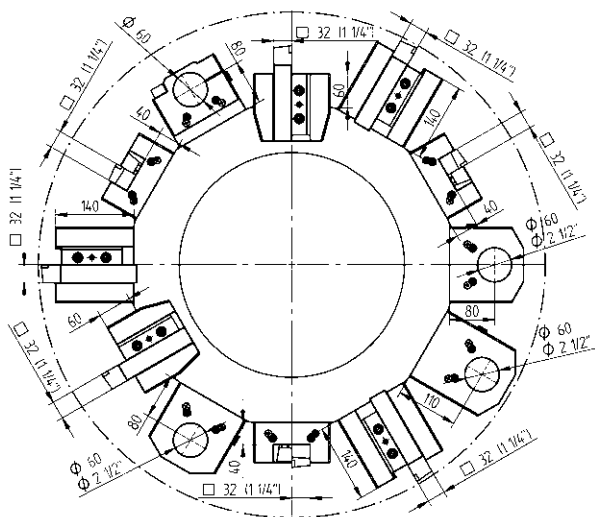

Porte-outils fixes - Programme standard



Porte-outil radial
 32 48-T00432
 T00432



Porte-outil radial, long (uniquement pour tourelle 1)
 32 48-T00434
 T00434



Porte-outil axial
 32 48-T03042
 T03042



Porte-outil combiné, LF=80
 Ø 60 48-T10203 IC 80 bar
 T10203
 Ø 80 48-115987 IC 80 bar



Porte-outil combiné, LF=110
 Ø 60 48-T12149 IC 80 bar
 T12149

Porte-outils fixes - Programme élargi



Porte-barre d'alésage, avec fente
 Ø 60 48-108639



Porte-barre d'alésage, avec fente (uniquement pour tourelle 1)
 Ø 80 48-118772

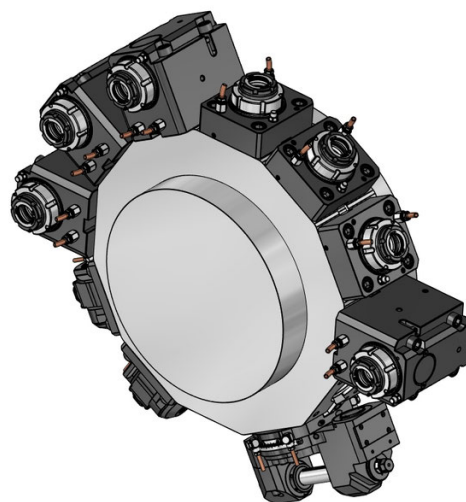
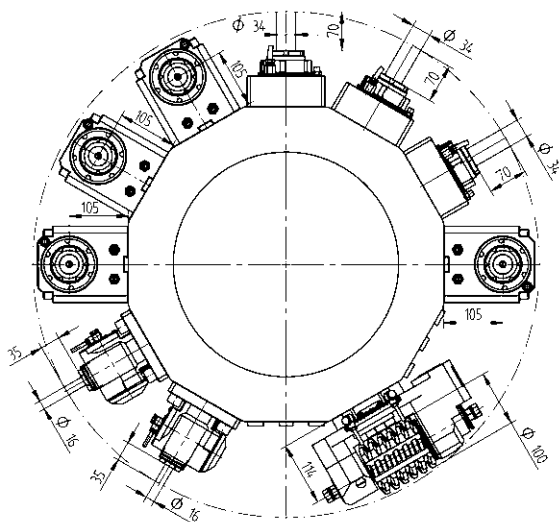

Porte-outils entraînés - QuickFlex®



Porte-outil d'alésage et de fraisage droit (8000 tr/min)

- | | | | |
|-----------------|------------------------|-----|-----------|
| ER-50 QF | 420150012-75
T32659 | 1:1 | EC |
| | 0067750000 | | |
| ER-50 QF | 420150013-75 | 1:1 | IC 80 bar |
| | 0067750000 | | |



Porte-outil d'alésage et de fraisage à renvoi d'angle (8000 tr/min)

- | | | | |
|-----------------|------------------------|-----|-----------|
| ER-50 QF | 420550012-75
T32660 | 1:1 | EC |
| | 0067750000 | | |
| ER-50 QF | 420550013-75 | 1:1 | IC 80 bar |
| | 0067750000 | | |

Porte-outils entraînés - Programme élargi



Porte-outil d'alésage et de fraisage à angle réglable

- | | | | |
|--------------|--------------|-----|-----------|
| ER 25 | 411016002-75 | 1:1 | EC |
| | 00675000934 | | |
| ER 25 | 411016003-75 | 1:1 | IC 80 bar |
| | 00675000934 | | |
| ER 16 | 411010004-75 | 1:2 | EC |
| | 00675000936 | | |
| ER 16 | 411010005-75 | 1:2 | IC 80 bar |
| | 00675000936 | | |



Unité de taillage de dentures

- | | | | |
|------------------|--------------------|-----|----|
| Type C5-1 | 410900000-75 | 2:1 | EC |
| | 00675001008 | | |
| | 160022C51 Ø 22 | | |
| | 160027C51 Ø 27 | | |
| | 160032C51 Ø 32 | | |
| | 160019C51 Ø 3/4" | | |
| | 160025C51 Ø 1" | | |
| | 160031C51 Ø 1 1/4" | | |
| | 110587 | | |

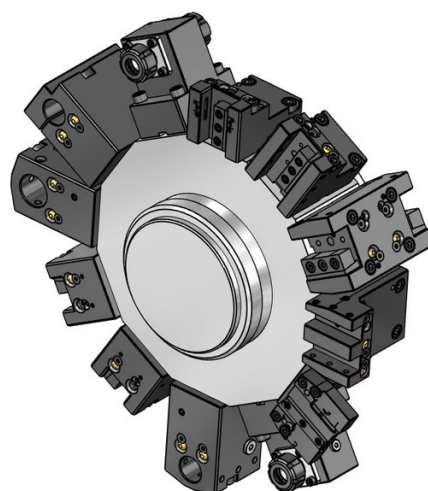
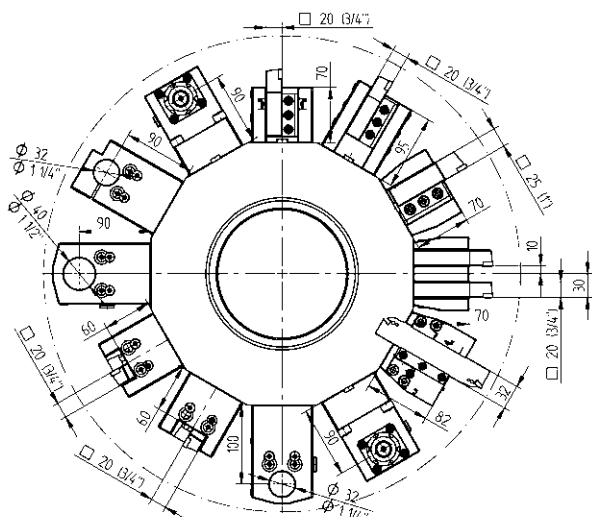

Porte-outils fixes - Programme standard



Porte-outil radial, court

- 20 48-T00224
T00224
- 25 48-T00267
T00267



Porte-outil radial, court, HP-IC

- 20 48-T00224-HP IC 80 bar
T00224
- 25 48-T00267-HP IC 80 bar
T00267



Porte-outil radial, long

- 20 48-T00225
T00225



Porte-outil radial, deux côtés, court

- 20 48-T00228
T00228
- 25 48-86523



Porte-outil radial, deux côtés, court, HP-IC

- 20 48-T00228-HP IC 80 bar
T00228
- 25 48-86523-HP IC 80 bar

Porte-outils fixes - Programme standard



Porte-outil radial, deux côtés, long

- 20 48-T00226
T00226



Porte-outil axial

- 25 48-T03024
T03024



Porte-outil axial, HP-IC

- 20 48-T03017-HP IC 80 bar
T03017



Porte-outil de tronçonnage, à droite

- 20 48-T00251
T00251
- 25 48-T00268
T00268, T00356



Porte-barre d'alésage

- Ø 32 48-T10115
T10115



Porte-outil combiné

- Ø 32 48-T13132 IC 80 bar
T13132
- Ø 40 48-77999 IC 80 bar

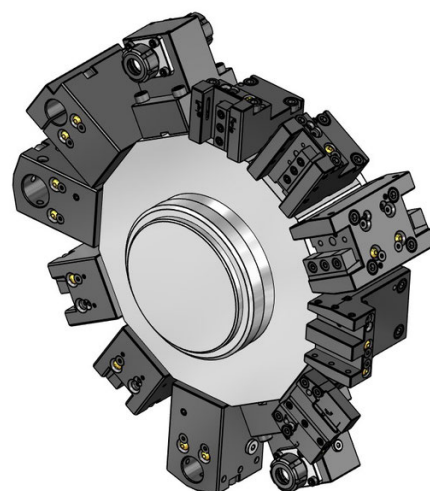
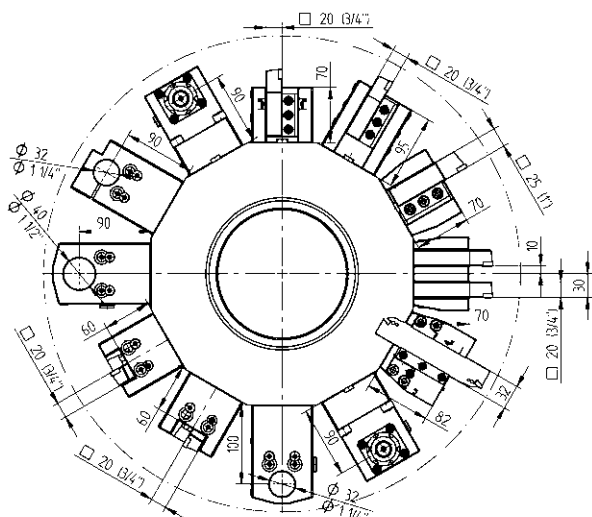

Porte-outils fixes - Programme élargi



Porte-outil radial, double, axe Y

20 (3/4") 48-77726



Porte-outil radial, deux côtés, double, axe Y

20 (3/4") 48-77727



Porte-outil axial, deux côtés

20 48-79608



Porte-outil de tronçonnage, réglable

SH 32 48-98891



Porte-outil de tronçonnage, réglable, HP-IC

SH 32 48-102261R IC 80 bar
SH 32 48-102261L IC 80 bar



Porte-barre d'alésage, avec fente

Ø 32 48-82057
Ø 40 48-82058

Porte-outils fixes - Programme élargi



Porte-pince

ER 25 48-107230 IC 80 bar

107525000

ER 32 48-81031 IC 80 bar

107532000



Porte-pince, deux côtés

ER 25 48-107227 IC 80 bar

107525000

ER 32 48-80509 IC 80 bar

107532000



Porte-barre d'alésage, ébauche

48-80506

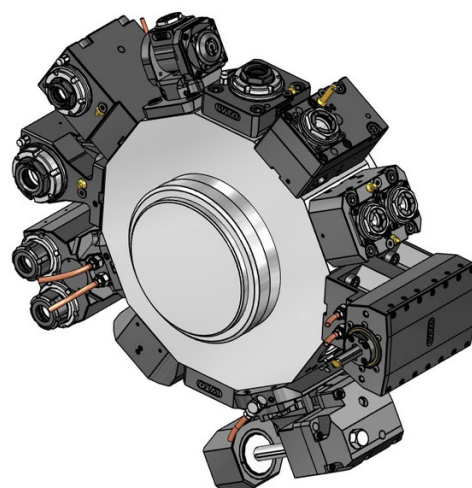
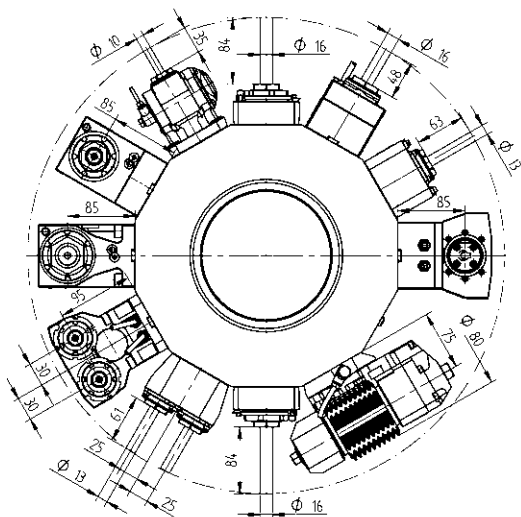

Porte-outils entraînés - QuickFlex®



Porte-outil d'alésage et de fraisage radial (12000 tr/min)

ER-25 QF	420125012-40 T32433	1:1	EC
	0067725000		
ER-25 QF	420125013-40	1:1	IC 80 bar
	0067725000		
ER-32 QF	QF32-DNE-MS40A-050-E-HS-A	1:1	EC
	0067732000		
ER-32 QF	QF32-DNE-MS40A-067-I-HS-A	1:1	IC 100 bar
	0067732000		



Porte-outil d'alésage et de fraisage radial (12000 tr/min) - QF smart (UE, US, CA, JP)

ER-32 QF	QF32-DNE-MS40A-067-I-HS-SB-A	1:1	IC 100 bar
	0067732000		
	LI-F12-01		



Porte-outil d'alésage et de fraisage radial (6000 tr/min, Heavy Duty)

ER-25 QF	420125010-40 T32274, T32450	1:1	EC
	0067725000		
ER-25 QF	420125011-40 T32287	1:1	IC 80 bar
	0067725000		
ER-32 QF	420132010-40 T32475, T32484	1:1	EC
	0067732000		
ER-32 QF	420132011-40	1:1	IC 80 bar
	0067732000		

Porte-outils entraînés - QuickFlex®



Porte-outil d'alésage et de fraisage axial (12000 tr/min)

ER-25 QF	420525013-40 T32434	1:1	EC
	0067725000		
ER-25 QF	420525014-40 T32436	1:1	IC 80 bar
	0067725000		
ER-32 QF	QF32-DNI-MS40A-085-E-HS-A	1:1	EC
	0067732000		
ER-32 QF	QF32-DNI-MS40A-085-I-HS-A	1:1	IC 100 bar
	0067732000		



Porte-outil d'alésage et de fraisage axial (12000 tr/min) - QF smart (UE, US, CA, JP)

ER-32 QF	QF32-DNI-MS40A-085-I-HS-SB-A	1:1	IC 100 bar
	0067732000		
	LI-F12-01		



Porte-outil d'alésage et de fraisage axial (6000 tr/min, Heavy Duty)

ER-25 QF	420525010-40 T32275, T32297	1:1	EC
	0067725000		
ER-25 QF	420525011-40 T32288, T32435	1:1	IC 80 bar
	0067725000		
ER-32 QF	420532010-40 T32476, T32485	1:1	EC
	0067732000		

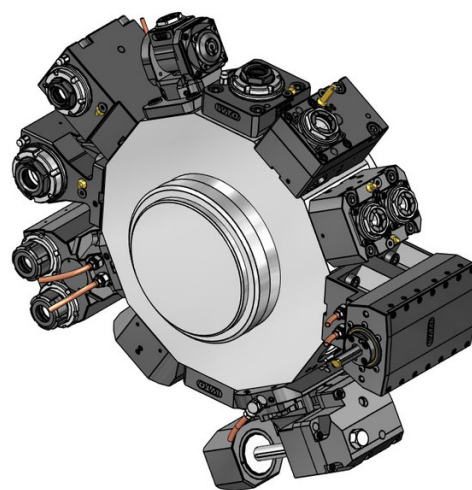
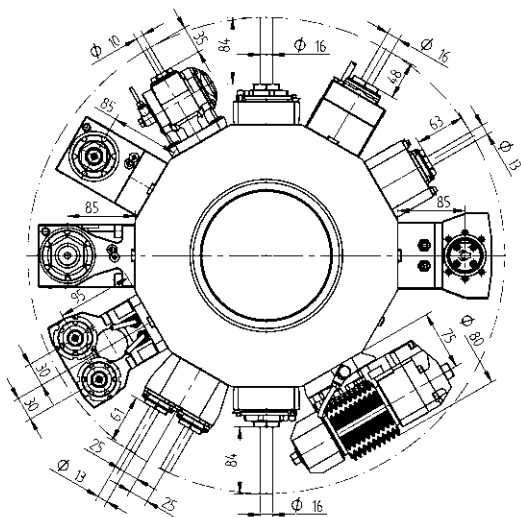

Porte-outils entrainés - QuickFlex®



Porte-outil d'alésage et de fraisage axial, deux côtés (12000 tr/min)

- ER-25 QF** 420525049-40 1:1 EC
 0067725000
- ER-32 QF** 420532148-40 1:1 EC
 0067732000



Porte-outil d'alésage et de fraisage axial pour pinces ER, deux côtés (6000 tr/min, Heavy Duty)

- ER-25 QF** 420525012-40 1:1 EC
 T32276, T32437
 0067725000
- ER-32 QF** 420532012-40 1:1 EC
 0067732000

Porte-outils entrainés - Programme élargi

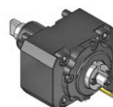

Porte-outil de fraisage radial avec arbre porte-fraise DIN 6358

- Ø 16** 410216010-40 1:1 EC
 00675000854
- Ø 22** 410222016-40 1:1 EC
 T32280, T32486
 00675000483



Porte-outil d'alésage et de fraisage radial, décalé

- ER 25** 410116050-40 1:1 EC
 T32488
 00675000932
- ER 25** 410116057-40 1:1 IC 80 bar
 00675000932
- ER 20** 410113060-40 1:2 EC
 00675000939
- ER 20** 410113068-40 1:2 IC 80 bar
 00675000939
- ER 16** 410410003-40 1:3 EC
 00675000937
- ER 16** 410410004-40 1:3 IC 80 bar
 00675000937
- ER 25** 410116051-40 2:1 EC
 00675000932
- ER 25** 410116058-40 2:1 IC 80 bar
 00675000932

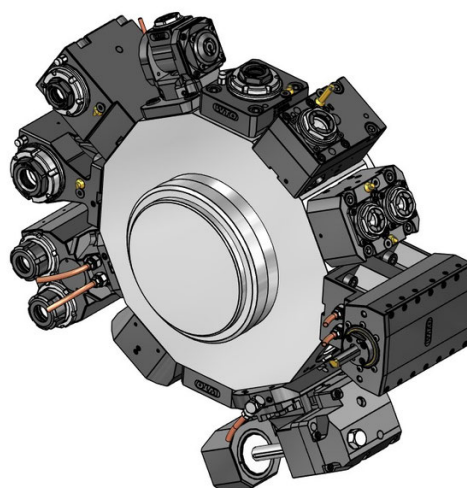
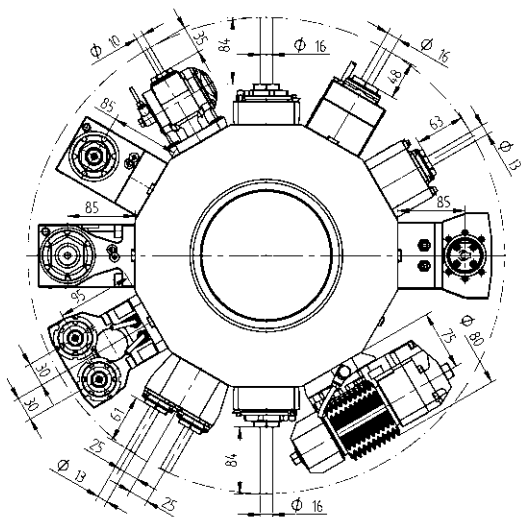

Porte-outils entraînés - Programme élargi



Porte-outil d'alésage et de fraisage radial, décalé (12000 tr/min)

- | | | | |
|--------------|--------------|-----|-----------|
| ER 25 | 410116060-40 | 1:1 | EC |
| | 00675000932 | | |
| ER 25 | 410116059-40 | 1:1 | IC 80 bar |
| | 00675000932 | | |



Porte-outil d'alésage et de fraisage axial

- | | | | |
|-----------------|--------------------------|-----|------------|
| ER-20 QF | 420520010-40 | 1:2 | EC |
| | 0067720001 | | |
| ER-20 QF | 420520011-40 | 1:2 | IC 80 bar |
| | 0067720001 | | |
| ER 16 | 410810012-40 | 1:3 | EC |
| | 0067825001 | | |
| ER 16 | 410810013-40 | 1:3 | IC 80 bar |
| | 0067825001 | | |
| ER-32 QF | 420532013-40 | 2:1 | EC |
| | 0067732000 | | |
| ER-32 QF | QF32-DNI-MS40A-085-I-T-A | 2:1 | IC 100 bar |
| | 0067732000 | | |



Porte-outil de fraisage axial avec arbre porte-fraise DIN 6358

- | | | | |
|-------------|--------------|-----|----|
| Ø 16 | 410616013-40 | 1:1 | EC |
| | 00675000854 | | |
| Ø 22 | 410622030-40 | 1:1 | EC |
| | 00675000483 | | |

Porte-outils entraînés - Programme élargi



Porte-outil d'alésage et de fraisage axial en retrait

- | | | | |
|--------------|--------------|-----|-----------|
| ER 25 | 410516153-40 | 1:1 | EC |
| | 00675000801 | | |
| ER 25 | 410516154-40 | 1:1 | IC 80 bar |
| | 00675000801 | | |



Porte-outil d'alésage et de fraisage à angle réglable

- | | | | |
|--------------|--------------|-----|-----------|
| ER 16 | 411010008-40 | 1:1 | EC |
| | 00675000913 | | |
| ER 16 | 411010009-40 | 1:1 | IC 80 bar |
| | 00675000913 | | |
| ER 11 | 411007001-40 | 1:2 | EC |
| | 00675000914 | | |
| ER 11 | 411007002-40 | 1:2 | IC 80 bar |
| | 00675000914 | | |

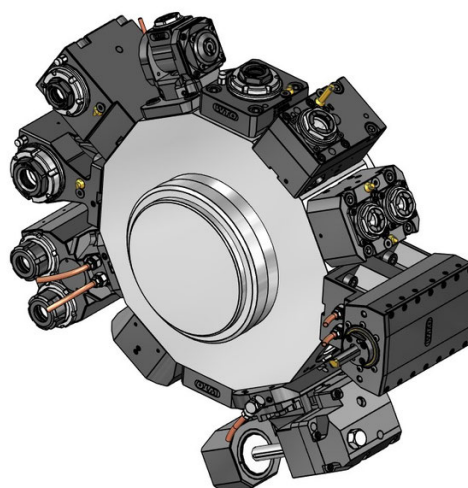
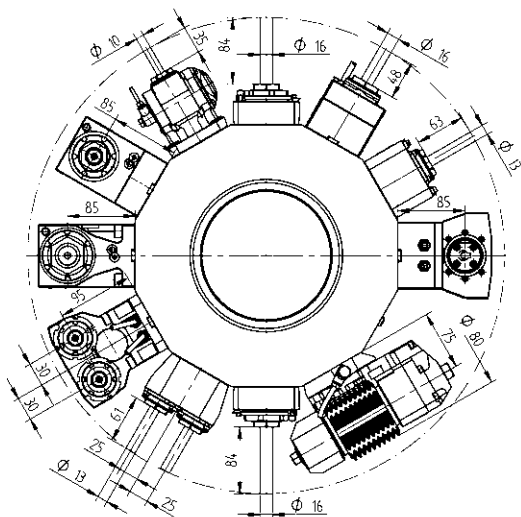

Porte-outils entrainés - Programme élargi



Unité de taillage de dentures

Type 16-1	411500017-40	1:1	EC
Type 16-1	411500018-40	2:1	EC
	00675000954		
	160016161 Ø 16		
	160022161 Ø 22		
	160027161 Ø 27		
	160015161 Ø 5/8"		
	160019161 Ø 3/4"		
	160025161 Ø 1"		
	160031161 Ø 1 1/4"		
	110587		



Porte-outil d'alésage et de fraisage radial, deux côtés

ER 20	413002015-40	1:1	EC
	00675000947		
ER 20	413002018-40	1:1	IC 80 bar
	00675000947		



Porte-outil d'alésage et de fraisage radial, double, axe Y

ER 20	413002014-40	1:1	EC
	00675000947		
ER 20	413002017-40	1:1	IC 80 bar
	00675000947		

Porte-outils entrainés - Programme élargi

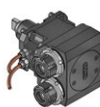

Porte-outil d'alésage et de fraisage axial double, axe Y

ER 25	413502008-40	1:1	EC
	00675000915		
ER 25	413502009-40	1:1	IC 80 bar
	00675000915		



Porte-outil d'alésage et de fraisage axial double, deux côtés, axe Y

ER 25	413502007-40	1:1	EC
	00675000915		



Unité de brochage intérieur et extérieur

Type 32	414532000-40	1:1	EC
----------------	--------------	-----	----



Unité de brochage intérieur et extérieur

Type 52	414552002-40	1:1	EC
----------------	--------------	-----	----

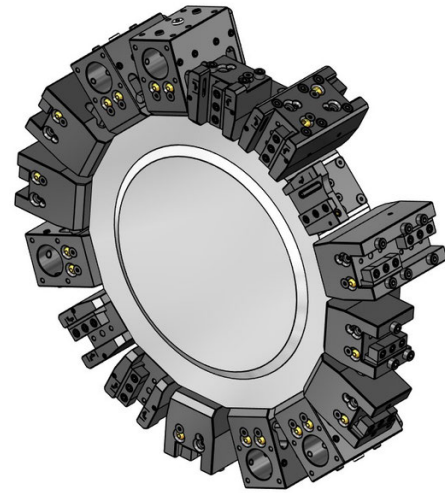
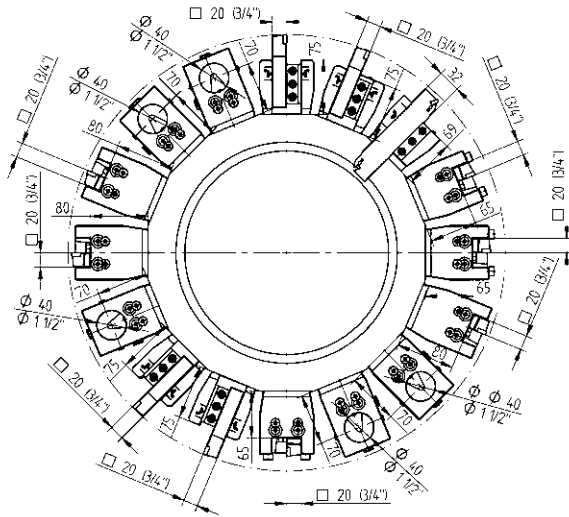

Porte-outils fixes - Programme standard

Porte-outils fixes - Programme élargi



Porte-outil radial, HP-IC

20 S020-TNE-MS42A-075-I-A IC 80 bar



Porte-outil radial, deux côtés, HP-IC

20 S020-TNE-MS42A-075-I-DT-A IC 80 bar



Porte-outil axial

20 S020-TNI-MS42A-087-E-A



Porte-outil axial

20 S020-TNI-MS42A-100-E-A



Porte-outil axial, deux côtés

20 S020-TNI-MS42A-087-E-DT-A

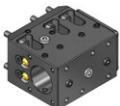

Porte-outil combiné, universel

Ø 40 D040-TNI-MS42A-070-I-DT-A IC 80 bar

241140020 ER32

241140026 ER40



Porte-outil de tronçonnage, réglable

SH 32 SH32-TNE-MS42A-077-E-A



Porte-outil de tronçonnage, réglable, HP-IC

SH 32 SH32-TRE-MS42A-077-I-A IC 80 bar

SH 32 SH32-TLE-MS42A-077-I-A IC 80 bar

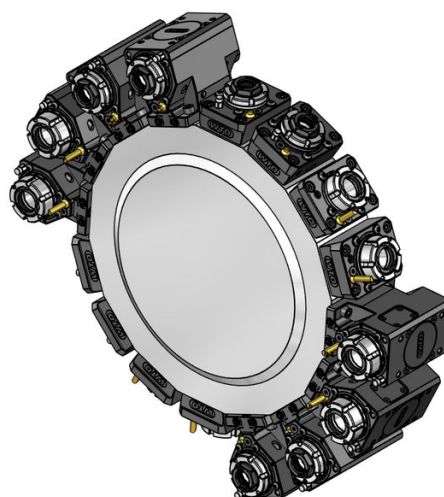
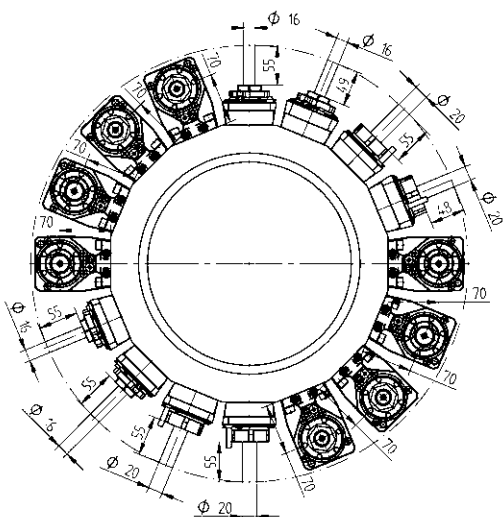

Porte-outils entrainés - QuickFlex®



Porte-outil d'alésage et de fraisage radial (12000 tr/min)

ER-25 QF	QF25-DNE-MS42A-047-E-A	1:1	EC
	0067725000		
ER-25 QF	QF25-DNE-MS42A-053-I-A	1:1	IC 100 bar
	0067725000		



Porte-outil d'alésage et de fraisage axial (12000 tr/min)

ER-25 QF	QF25-DNI-MS42A-070-E-A	1:1	EC
	0067725000		
ER-25 QF	QF25-DNI-MS42A-070-I-A	1:1	IC 100 bar
	0067725000		

Porte-outils entrainés - Programme élargi

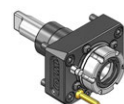

Porte-outil d'alésage et de fraisage radial (12000 tr/min)

ER 32	ER32-DNE-MS42A-055-E-A	1:1	EC
	0067725030		
ER 32	ER32-DNE-MS42A-062-I-A	1:1	IC 100 bar
	0067725030		



Porte-outil d'alésage et de fraisage axial (12000 tr/min)

ER 32	ER32-DNI-MS42A-070-E-A	1:1	EC
	0067725030		
ER 32	ER32-DNI-MS42A-070-I-A	1:1	IC 100 bar
	0067725030		

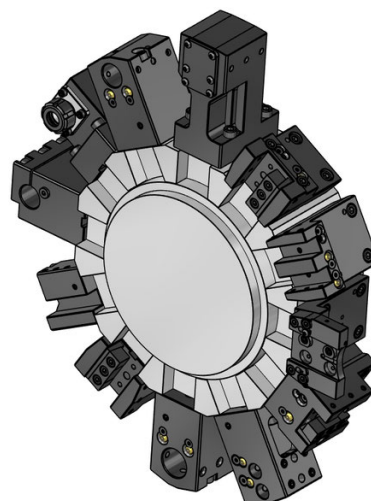
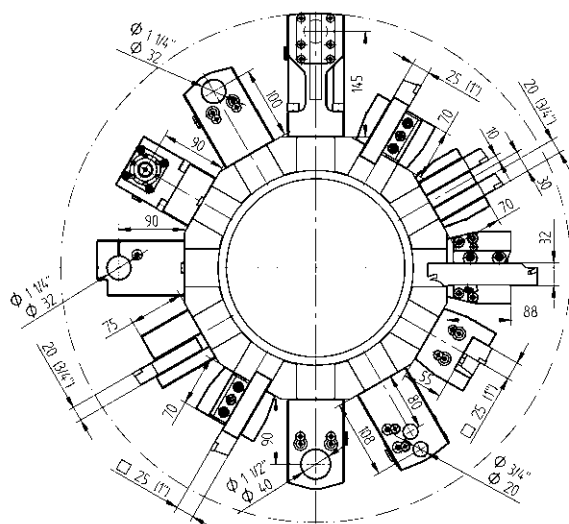

Porte-outils fixes - Programme standard



Porte-outil radial, court

- 20 48-T00224
T00224
- 25 48-T00267
T00267



Porte-outil radial, court, HP-IC

- 20 48-T00224-HP IC 80 bar
T00224
- 25 48-T00267-HP IC 80 bar
T00267



Porte-outil radial, long

- 20 48-T00225
T00225



Porte-outil radial, deux côtés, court

- 20 48-T00228
T00228
- 25 48-86523



Porte-outil radial, deux côtés, court, HP-IC

- 20 48-T00228-HP IC 80 bar
T00228
- 25 48-86523-HP IC 80 bar

Porte-outils fixes - Programme standard



Porte-outil radial, deux côtés, long

- 20 48-T00226
T00226



Porte-outil axial

- 25 48-T03024
T03024



Porte-outil axial, HP-IC

- 20 48-T03017-HP IC 80 bar
T03017



Porte-outil de tronçonnage, à droite

- 20 48-T00251
T00251
- 25 48-T00268
T00268, T00356



Porte-barre d'alésage

- Ø 32 48-T10115
T10115



Porte-outil combiné

- Ø 32 48-T13132 IC 80 bar
T13132
- Ø 40 48-77999 IC 80 bar

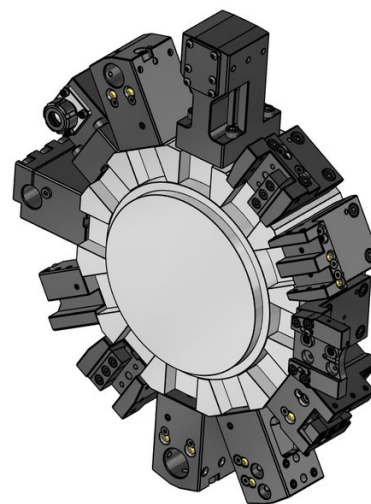
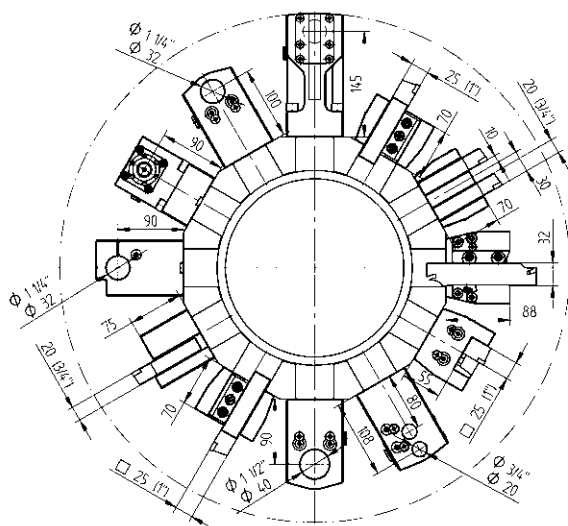

Porte-outils fixes - Programme standard



Ø 32

Porte-outil combiné, broche de reprise

48-T10260
T10260

IC 80 bar

Porte-outils fixes - Programme élargi



20 (3/4")

Porte-outil radial, double, axe Y

48-77726



20

Porte-outil radial, deux côtés, court, allongé

48-79403



20

Porte-outil radial, deux côtés, long, allongé

48-81414



SH 32

Porte-outil de tronçonnage, réglable

48-98891



SH 32

Porte-outil de tronçonnage, réglable, HP-IC

48-102261R

IC 80 bar

SH 32 48-102261L

IC 80 bar



Ø 32

Porte-barre d'alésage, avec fente

48-82057

Ø 40 48-82058



Ø 20

Porte-barre d'alésage, double, universel

48-75406

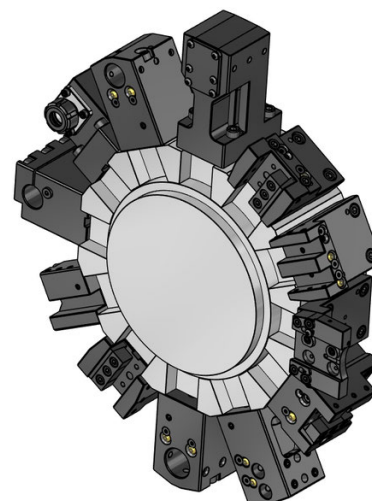
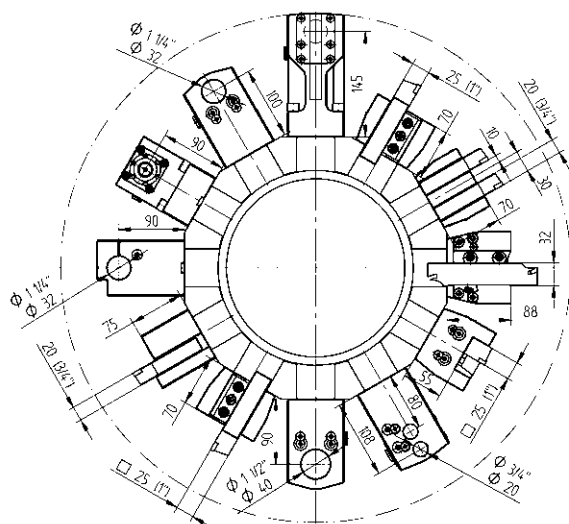

Porte-outils fixes - Programme élargi



Porte-pince

ER 25 48-107230 IC 80 bar

 107525000

ER 32 48-81031 IC 80 bar

 107532000



Adaptateur VDI, gauche

VDI 30 48-77732



Adaptateur VDI, droite

VDI 30 48-78687



Porte-barre d'alésage, ébauche

48-80506

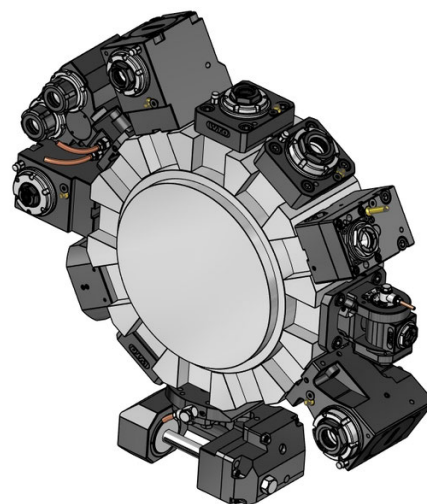
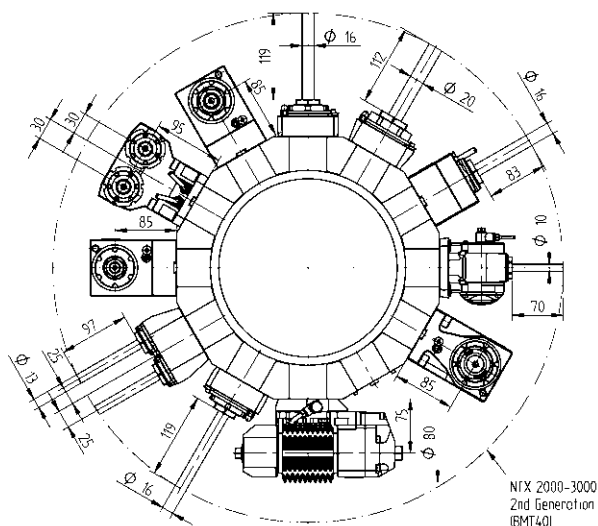

Porte-outils entrainés - QuickFlex®



Porte-outil d'alésage et de fraisage radial (12000 tr/min)

ER-25 QF	420125012-40 T32433	1:1	EC
	0067725000		
ER-25 QF	420125013-40	1:1	IC 80 bar
	0067725000		
ER-32 QF	QF32-DNE-MS40A-050-E-HS-A	1:1	EC
	0067732000		
ER-32 QF	QF32-DNE-MS40A-067-I-HS-A	1:1	IC 100 bar
	0067732000		



Porte-outil d'alésage et de fraisage radial (12000 tr/min) - QF smart (UE, US, CA, JP)

ER-32 QF	QF32-DNE-MS40A-067-I-HS-SB-A	1:1	IC 100 bar
	0067732000		
	LI-F12-01		



Porte-outil d'alésage et de fraisage radial (6000 tr/min, Heavy Duty)

ER-25 QF	420125010-40 T32274, T32450	1:1	EC
	0067725000		
ER-25 QF	420125011-40 T32287	1:1	IC 80 bar
	0067725000		
ER-32 QF	420132010-40 T32475, T32484	1:1	EC
	0067732000		
ER-32 QF	420132011-40	1:1	IC 80 bar
	0067732000		

Porte-outils entrainés - QuickFlex®



Porte-outil d'alésage et de fraisage axial (12000 tr/min)

ER-25 QF	420525013-40 T32434	1:1	EC
	0067725000		
ER-25 QF	420525014-40 T32436	1:1	IC 80 bar
	0067725000		
ER-32 QF	QF32-DNI-MS40A-085-E-HS-A	1:1	EC
	0067732000		
ER-32 QF	QF32-DNI-MS40A-085-I-HS-A	1:1	IC 100 bar
	0067732000		



Porte-outil d'alésage et de fraisage axial (12000 tr/min) - QF smart (UE, US, CA, JP)

ER-32 QF	QF32-DNI-MS40A-085-I-HS-SB-A	1:1	IC 100 bar
	0067732000		
	LI-F12-01		



Porte-outil d'alésage et de fraisage axial (6000 tr/min, Heavy Duty)

ER-25 QF	420525010-40 T32275, T32297	1:1	EC
	0067725000		
ER-25 QF	420525011-40 T32288, T32435	1:1	IC 80 bar
	0067725000		
ER-32 QF	420532010-40 T32476, T32485	1:1	EC
	0067732000		

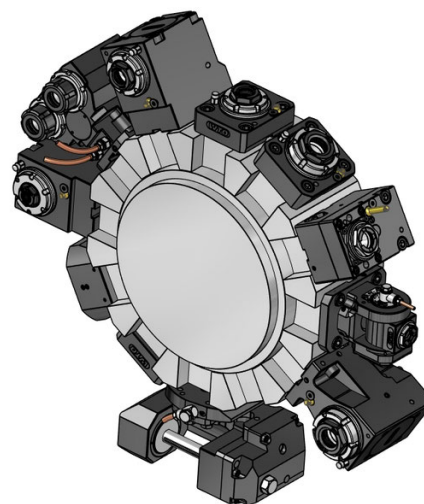
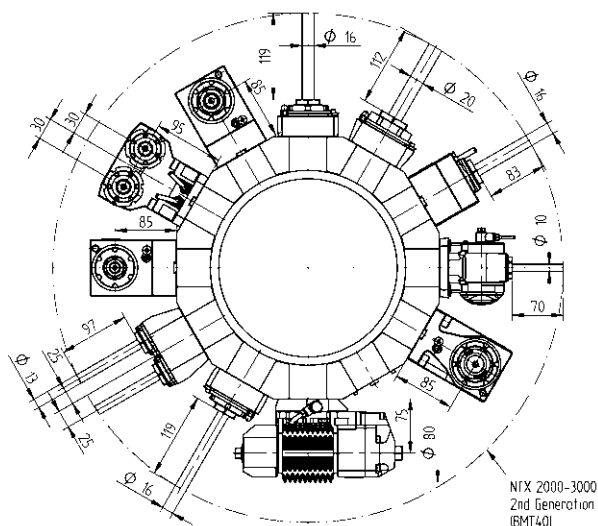

Porte-outils entrainés - QuickFlex®



Porte-outil d'alésage et de fraisage à renvoi d'angle en retrait, broche de Reprise (uniquement pour NTX 1000 S2 2nd Generation)

ER-25 QF	420525047-40	1:1	EC
	0067725010		
ER-25 QF	420525048-40	1:1	IC 80 bar
	0067725010		



Porte-outil d'alésage et de fraisage axial, broche de Reprise (uniquement pour NTX 2000-3000 S2 2nd Generation)

ER-20 QF	420520016-40	1:1	EC
	0067720000		
ER-20 QF	420520017-40	1:1	IC 80 bar
	0067720000		

Porte-outils entrainés - Programme élargi

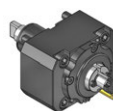

Porte-outil de fraisage radial avec arbre porte-fraise DIN 6358

Ø 16	410216010-40	1:1	EC
	00675000854		
Ø 22	410222016-40	1:1	EC
	T32280, T32486		
	00675000483		



Porte-outil d'alésage et de fraisage radial, décalé

ER 25	410116050-40	1:1	EC
	T32488		
	00675000932		
ER 25	410116057-40	1:1	IC 80 bar
	00675000932		
ER 20	410113060-40	1:2	EC
	00675000939		
ER 20	410113068-40	1:2	IC 80 bar
	00675000939		
ER 16	410410003-40	1:3	EC
	00675000937		
ER 16	410410004-40	1:3	IC 80 bar
	00675000937		
ER 25	410116051-40	2:1	EC
	00675000932		
ER 25	410116058-40	2:1	IC 80 bar
	00675000932		

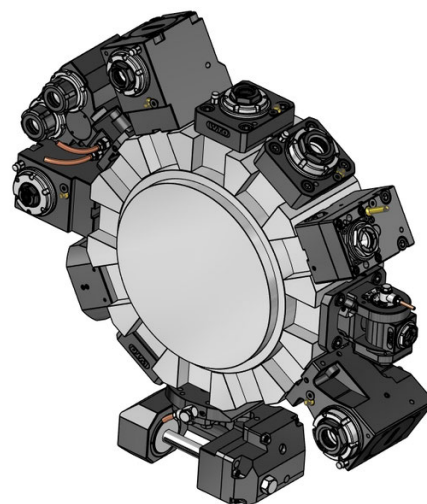
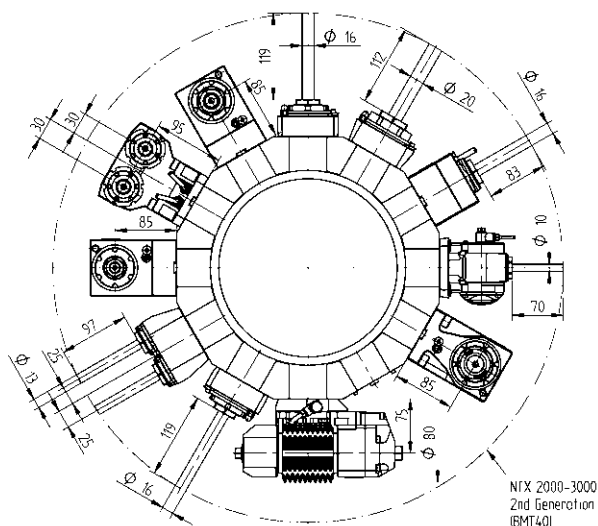

Porte-outils entraînés - Programme élargi



Porte-outil d'alésage et de fraisage radial, décalé (12000 tr/min)

ER 25	410116060-40	1:1	EC
	00675000932		
ER 25	410116059-40	1:1	IC 80 bar
	00675000932		



Porte-outil d'alésage et de fraisage axial

ER-20 QF	420520010-40	1:2	EC
	0067720001		
ER-20 QF	420520011-40	1:2	IC 80 bar
	0067720001		
ER 16	410810012-40	1:3	EC
	0067825001		
ER 16	410810013-40	1:3	IC 80 bar
	0067825001		
ER-32 QF	420532013-40	2:1	EC
	0067732000		
ER-32 QF	QF32-DNI-MS40A-085-I-T-A	2:1	IC 100 bar
	0067732000		



Porte-outil de fraisage axial avec arbre porte-fraise DIN 6358

Ø 16	410616013-40	1:1	EC
	00675000854		
Ø 22	410622030-40	1:1	EC
	00675000483		

Porte-outils entraînés - Programme élargi



Porte-outil d'alésage et de fraisage à angle réglable

ER 16	411010008-40	1:1	EC
	00675000913		
ER 16	411010009-40	1:1	IC 80 bar
	00675000913		
ER 11	411007001-40	1:2	EC
	00675000914		
ER 11	411007002-40	1:2	IC 80 bar
	00675000914		



Unité de taillage de dentures

Type 16-1	411500017-40	1:1	EC
Type 16-1	411500018-40	2:1	EC
	00675000954		
	160016161 Ø 16		
	160022161 Ø 22		
	160027161 Ø 27		
	160015161 Ø 5/8"		
	160019161 Ø 3/4"		
	160025161 Ø 1"		
	160031161 Ø 1 1/4"		
	110587		

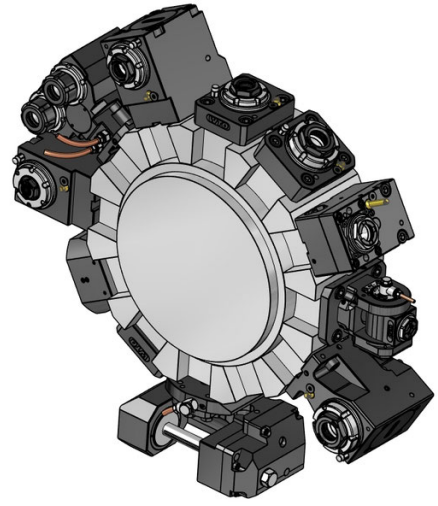
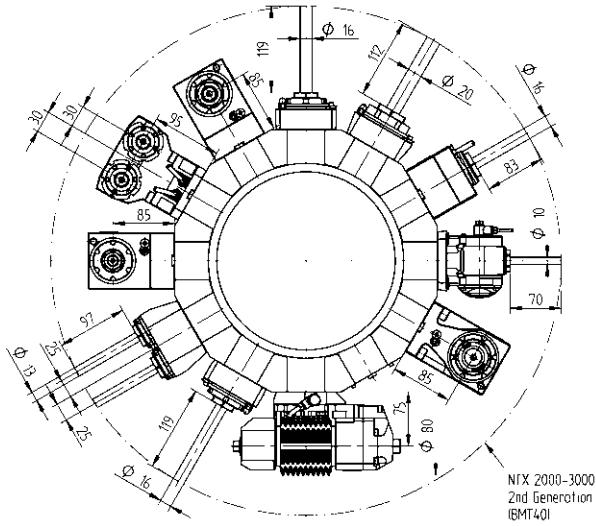

Porte-outils entrainés - Programme élargi



Porte-outil d'alésage et de fraisage radial, deux côtés

ER 20 413002015-40 1:1 EC
 00675000947

ER 20 413002018-40 1:1 IC 80 bar
 00675000947



Porte-outil d'alésage et de fraisage radial, double, axe Y

ER 20 413002014-40 1:1 EC
 00675000947

ER 20 413002017-40 1:1 IC 80 bar
 00675000947



Porte-outil d'alésage et de fraisage axial double, axe Y

ER 25 413502008-40 1:1 EC
 00675000915

ER 25 413502009-40 1:1 IC 80 bar
 00675000915

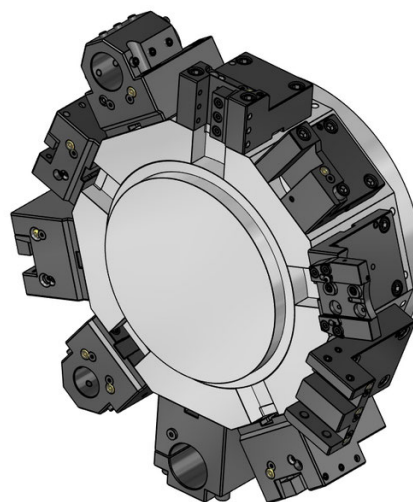
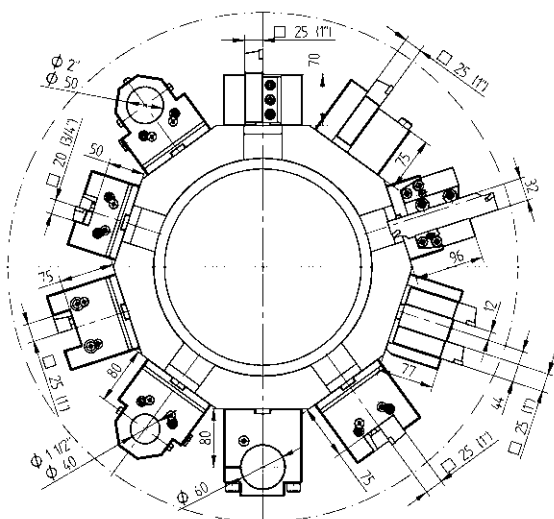

Porte-outils fixes - Programme standard



Porte-outil radial

- 20 48-T00187
T00187
- 25 48-T00186
T00186



Porte-outil radial, HP-IC

- 25 48-T00186-HP IC 80 bar
T00186



Porte-outil radial, deux côtés

- 20 48-T00185
T00185
- 25 48-T00184
T00184



Porte-outil radial, deux côtés, HP-IC

- 25 48-T00184-HP IC 80 bar
T00184



Porte-outil axial

- 20 48-T03006
T03006
- 25 48-T03005
T03005

Porte-outils fixes - Programme standard



Porte-outil axial, HP-IC

- 25 48-T03005-HP IC 80 bar
T03005



Porte-outil de tronçonnage, à droite

- 25 48-T00197
T00197



Porte-barre d'alésage, LF=80

- Ø 40 48-T10097
T10097
- Ø 50 48-T10098
T10098



Porte-outil combiné, LF=80

- Ø 40 48-T13128 IC 80 bar
T13128
- Ø 50 48-T13139 IC 80 bar
T13139

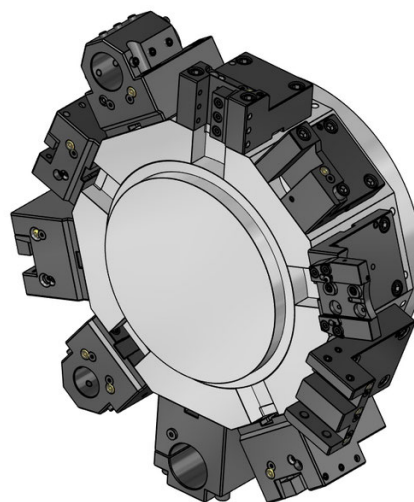
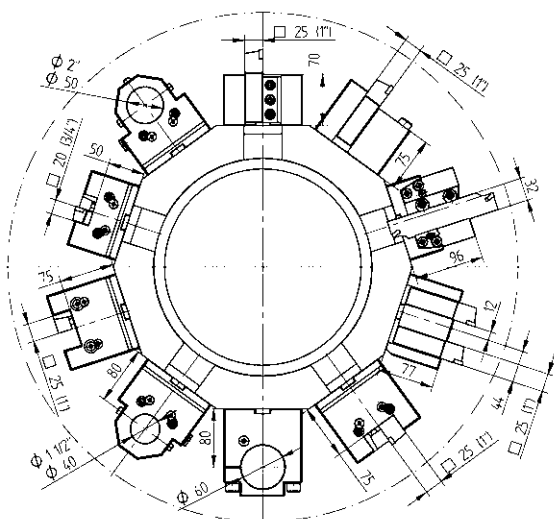

Porte-outils fixes - Programme élargi

Porte-outils fixes - Programme élargi



25

Porte-outil radial, à droite, long, HP-IC

48-T00385-HP IC 80 bar
T00385



25

Porte-outil radial, gauche, long, HP-IC

48-T00387-HP IC 80 bar
T00387



25(1")

Porte-outil radial, double, axe Y

48-71865
T00206, T00210



25(1")

Porte-outil radial, deux côtés, double, axe Y

48-71863
T00253, T00258



SH 32

Porte-outil de tronçonnage, réglable

48-98901



SH 32

Porte-outil de tronçonnage, réglable, HP-IC

48-102262R IC 80 bar
SH 32 48-102262L IC 80 bar



SH 32

Porte-outil de tronçonnage, réglable, allongé

48-77478



Ø 40

Porte-barre d'alésage, avec fente

48-T10136
T10136

Ø 50

48-T10137
T10137

Ø 60

48-70811



VDI 30

Adaptateur VDI, gauche

VDI 40

48-77127
48-72984



VDI 30

Adaptateur VDI, droite

VDI 40

48-74796
48-77955



48-81080

Porte-barre d'alésage, ébauche

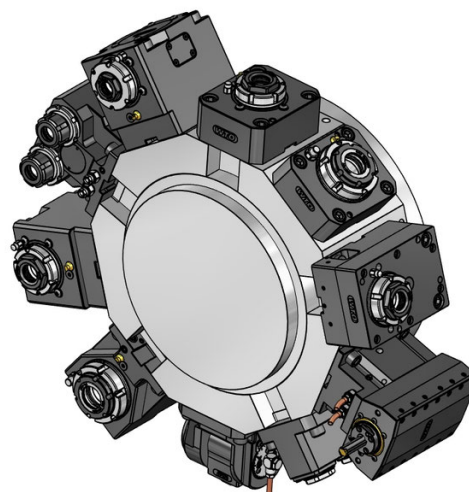
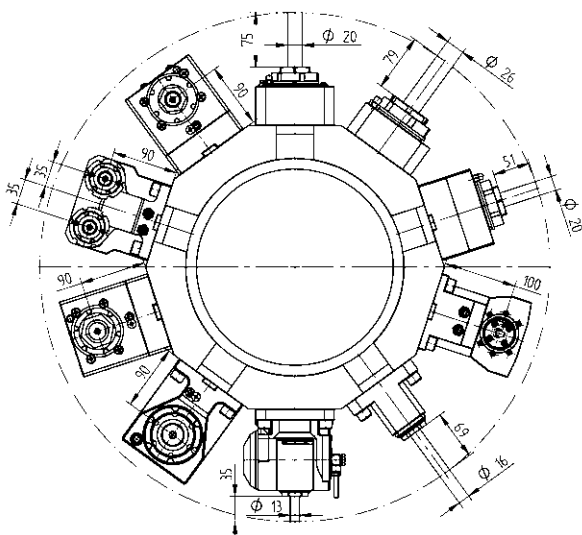

Porte-outils entraînés - QuickFlex®



Porte-outil d'alésage et de fraisage radial (12000 tr/min)

- ER-32 QF QF32-DNE-MS60A-072-E-HS-A 1:1 EC
0067732000
- ER-32 QF QF32-DNE-MS60A-072-I-HS-A 1:1 IC 100 bar
0067732000



Porte-outil d'alésage et de fraisage radial (12000 tr/min) - QF smart (UE, US, CA, JP)

- ER-32 QF QF32-DNE-MS60A-072-I-HS-SB-A 1:1 IC 100 bar
0067732000
- LI-F12-01



Porte-outil d'alésage et de fraisage radial (6000 tr/min, Heavy Duty)

- ER-32 QF 420132011-60 1:1 IC 80 bar
T32232, T32478
0067732000
- ER-40 QF 420140010-60 1:1 EC
T32213
0067740000
- ER-40 QF 420140011-60 1:1 IC 80 bar
T32234
0067740000



Porte-outil d'alésage et de fraisage axial (12000 tr/min)

- ER-32 QF QF32-DNI-MS60A-090-E-HS-A 1:1 EC
0067732000
- ER-32 QF QF32-DNI-MS60A-090-I-HS-A 1:1 IC 100 bar
0067732000

Porte-outils entraînés - QuickFlex®



Porte-outil d'alésage et de fraisage axial (12000 tr/min) - QF smart (UE, US, CA, JP)

- ER-32 QF QF32-DNI-MS60A-090-I-HS-SB-A 1:1 IC 100 bar
0067732000
- LI-F12-01



Porte-outil d'alésage et de fraisage axial (6000 tr/min, Heavy Duty)

- ER-40 QF 420540012-60 1:1 EC
T32214
0067740000
- ER-40 QF 420540013-60 1:1 IC 80 bar
T32235
0067740000

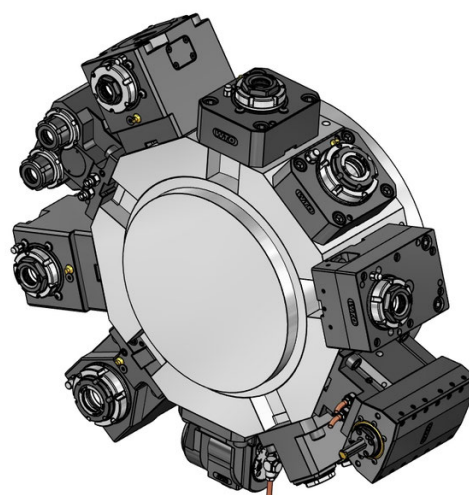
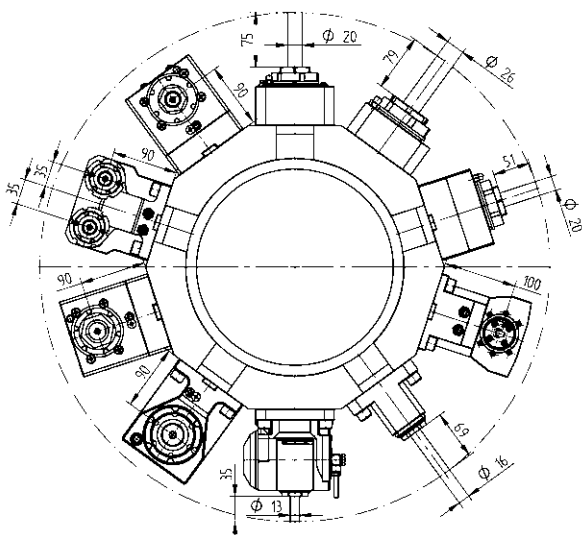

Porte-outils entraînés - Programme élargi



Porte-outil de fraisage radial avec arbre porte-fraise DIN 6358

Ø 16	410216000-60 00675000854	1:1	EC
Ø 22	410222007-60 T32268 00675000483	1:1	EC
Ø 27	410227008-60 00675000245	1:1	EC



Porte-outil d'alésage et de fraisage radial, décalé

ER-32 QF	420132019-60 0067732000	1:1	EC
ER-32 QF	420132020-60 0067732000	1:1	IC 80 bar
ER-25 QF	420125010-60 0067725001	1:2	EC
ER-25 QF	420125011-60 0067725001	1:2	IC 80 bar
ER-32 QF	420132021-60 0067732000	2:1	EC
ER-32 QF	420132022-60 0067732000	2:1	IC 80 bar



Porte-outil d'alésage et de fraisage axial

ER-25 QF	QF25-DNI-MS60A-090-E-S-A 0067725001	1:2	EC
ER-25 QF	QF25-DNI-MS60A-090-I-S-A 0067725001	1:2	IC 100 bar
ER-40 QF	420540014-60 0067740000	2:1	EC
ER-40 QF	420540015-60 0067740000	2:1	IC 80 bar

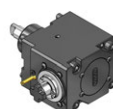

Porte-outil de fraisage axial avec arbre porte-fraise DIN 6358

Ø 22	M022-DNI-MS60A-090-E-T-A 00675000483	2:1	EC
Ø 27	M027-DNI-MS60A-090-E-T-A 00675000245	2:1	EC



Porte-outil d'alésage et de fraisage à angle réglable

ER 20	411013009-60 T32474 00675000928	1:1	EC
ER 20	411013010-60 00675000928	1:1	IC 80 bar
ER 16	411010001-60 00675000936	1:2	EC
ER 16	411010002-60 00675000936	1:2	IC 80 bar

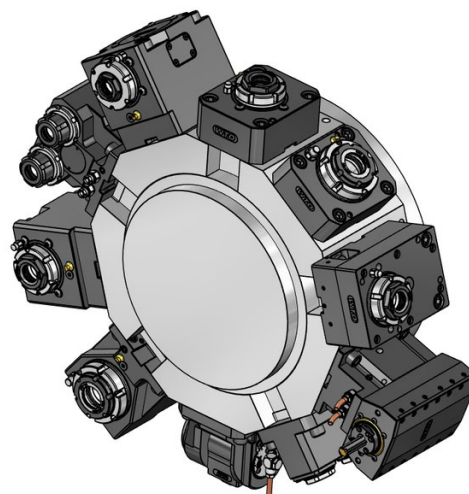
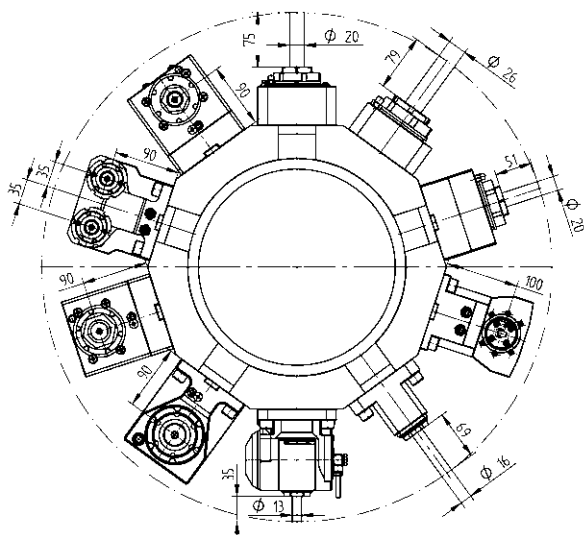

Porte-outils entrainés - Programme élargi



Porte-outil d'alésage et de fraisage radial, deux côtés

ER 25 413002001-60 1:1 EC
 00675000907



Porte-outil d'alésage et de fraisage radial, double, axe Y

ER 25 413002000-60 1:1 EC
 T32267

00675000907

ER 25 413002012-60 1:1 IC 80 bar

00675000907



Porte-outil d'alésage et de fraisage axial double, axe Y

ER 25 413502000-60 1:1 EC
 T32264

00675000915

ER 25 413502002-60 1:1 IC 80 bar

00675000915



Unité de brochage intérieur et extérieur

Type 32 414532000-60 1:1 EC

Type 52 414552000-60 1:1 EC

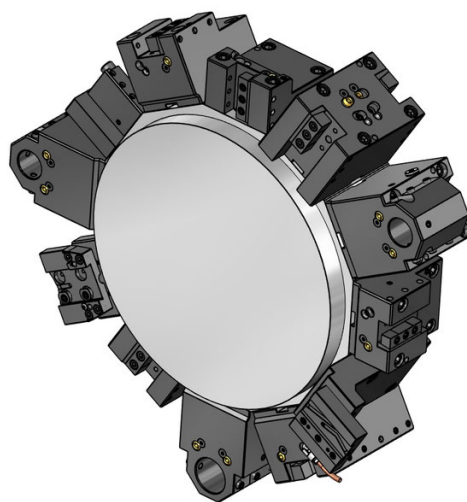
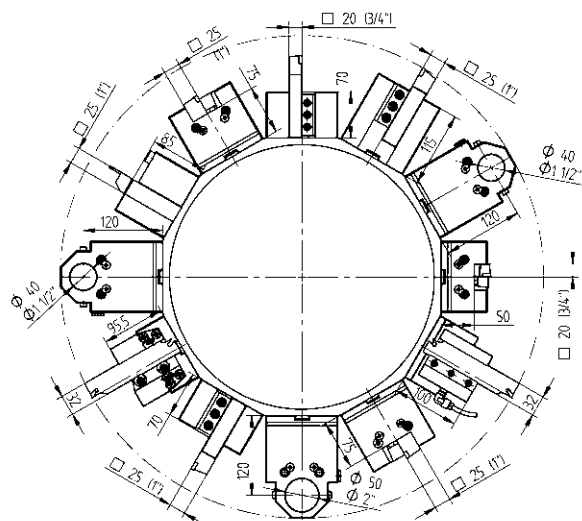

Porte-outils fixes - Programme standard



Porte-outil radial

- 20 48-T00187
T00187
- 25 48-T00186
T00186



Porte-outil radial, HP-IC

- 25 48-T00186-HP IC 80 bar
T00186



Porte-outil radial, deux côtés

- 20 48-T00185
T00185
- 25 48-T00184
T00184



Porte-outil radial, deux côtés, HP-IC

- 25 48-T00184-HP IC 80 bar
T00184



Porte-outil radial, deux côtés, long

- 25 48-T00237
T00237

Porte-outils fixes - Programme standard

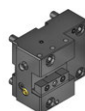

Porte-outil axial

- 20 48-T03006
T03006
- 25 48-T03005
T03005



Porte-outil axial, HP-IC

- 25 48-T03005-HP IC 80 bar
T03005



Porte-outil de tronçonnage, à droite

- 25 48-T00197
T00197



Porte-barre d'alésage, LF=120

- Ø 40 48-T10113
T10113
- Ø 50 48-T10114
T10114



Porte-outil combiné, LF=120

- Ø 40 48-T13131 IC 80 bar
T13131
- Ø 50 48-77902 IC 80 bar

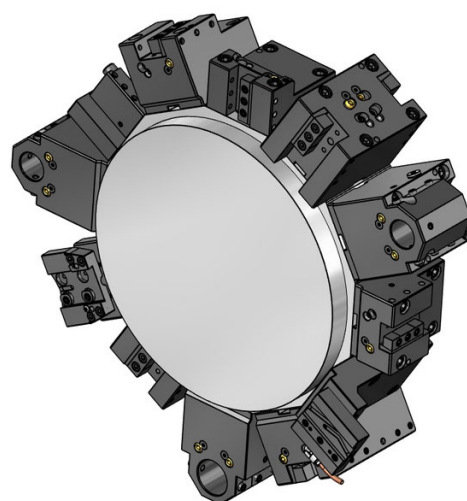
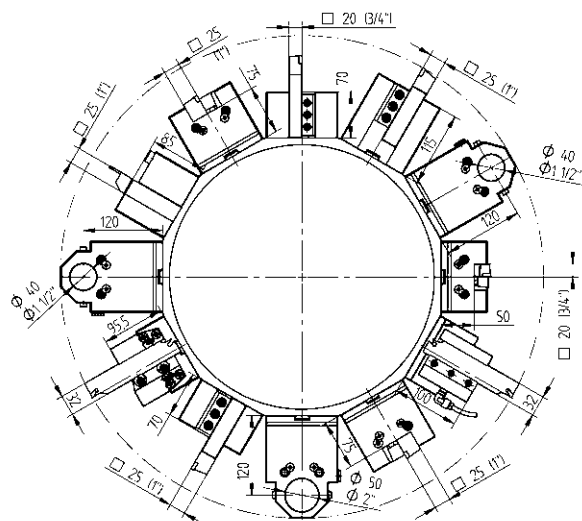

Porte-outils fixes - Programme élargi



Porte-outil radial, à droite, long, HP-IC
25 48-T00385-HP IC 80 bar
 T00385



Porte-outil radial, gauche, long, HP-IC
25 48-T00387-HP IC 80 bar
 T00387



Porte-outil radial, allongé
25 48-76267

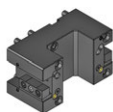

Porte-outil radial, deux côtés, allongé
25 48-81627



Porte-outil axial, deux côtés
25 48-78995



Porte-outil de tronçonnage, réglable
SH 32 48-98901



Porte-outil de tronçonnage, réglable, HP-IC
SH 32 48-102262R IC 80 bar
SH 32 48-102262L IC 80 bar

Porte-outils fixes - Programme élargi



Porte-outil de tronçonnage, réglable, allongé
SH 32 48-77478

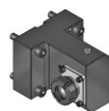

Porte-pince
ER 32 48-94564 IC 80 bar
 107532000

ER 40 48-94566 IC 80 bar
 107540000



Porte-pince, deux côtés
ER 32 48-94565 IC 80 bar
 107532000

ER 40 48-94567 IC 80 bar
 107540000



Adaptateur VDI, gauche
VDI 30 48-77127
VDI 40 48-72984



Adaptateur VDI, droite
VDI 30 48-74796
VDI 40 48-77955

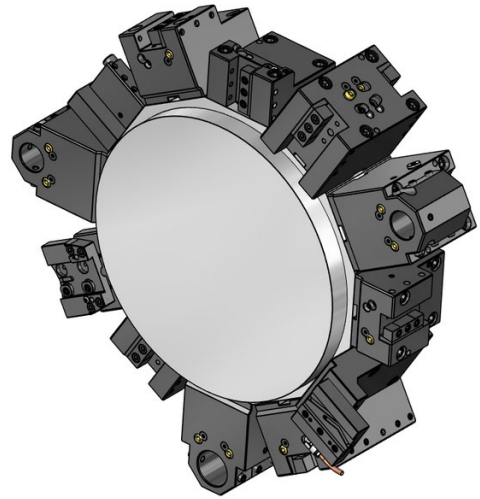
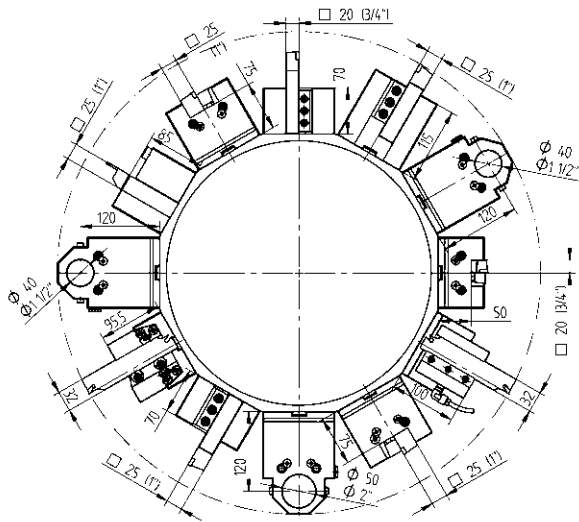

Porte-outils fixes - Programme élargi



Porte-barre d'alésage, ébauche

48-81081

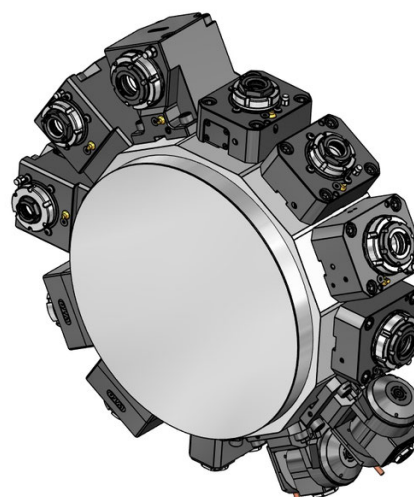
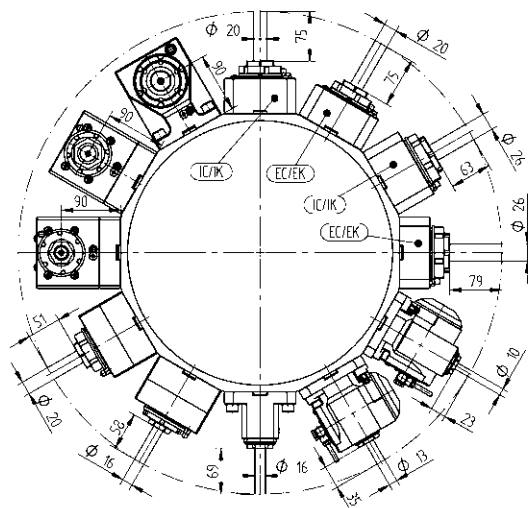

Porte-outils entrainés - QuickFlex®



Porte-outil d'alésage et de fraisage radial (12000 tr/min)

- ER-32 QF** QF32-DNE-MS60A-072-E-HS-A 1:1 EC
0067732000
- ER-32 QF** QF32-DNE-MS60A-072-I-HS-A 1:1 IC 100 bar
0067732000



Porte-outil d'alésage et de fraisage radial (12000 tr/min) - QF smart (UE, US, CA, JP)

- ER-32 QF** QF32-DNE-MS60A-072-I-HS-SB-A 1:1 IC 100 bar
0067732000
- LI-F12-01



Porte-outil d'alésage et de fraisage radial (6000 tr/min, Heavy Duty)

- ER-32 QF** 420132011-60 T32232, T32478 1:1 IC 80 bar
0067732000
- ER-40 QF** 420140010-60 T32213 1:1 EC
0067740000
- ER-40 QF** 420140011-60 T32234 1:1 IC 80 bar
0067740000



Porte-outil d'alésage et de fraisage axial (12000 tr/min)

- ER-32 QF** QF32-DNI-MS60A-090-E-HS-A 1:1 EC
0067732000
- ER-32 QF** QF32-DNI-MS60A-090-I-HS-A 1:1 IC 100 bar
0067732000

Porte-outils entrainés - QuickFlex®



Porte-outil d'alésage et de fraisage axial (12000 tr/min) - QF smart (UE, US, CA, JP)

- ER-32 QF** QF32-DNI-MS60A-090-I-HS-SB-A 1:1 IC 100 bar
0067732000
- LI-F12-01



Porte-outil d'alésage et de fraisage axial (6000 tr/min, Heavy Duty)

- ER-40 QF** 420540012-60 T32214 1:1 EC
0067740000
- ER-40 QF** 420540013-60 T32235 1:1 IC 80 bar
0067740000



Porte-outil d'alésage et de fraisage axial pour pinces ER, deux côtés (6000 tr/min, Heavy Duty)

- ER-32 QF** 420532019-60 T32216 1:1 EC
0067732000
- ER-40 QF** 420540016-60 T32248 1:1 EC
0067740000

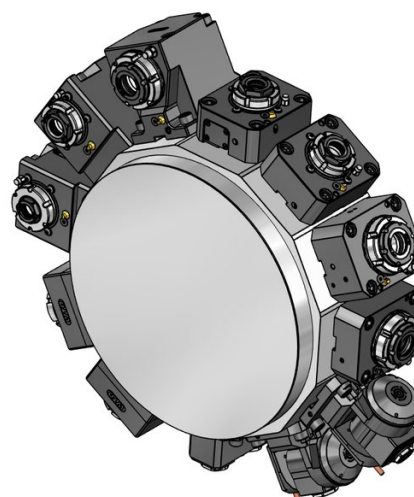
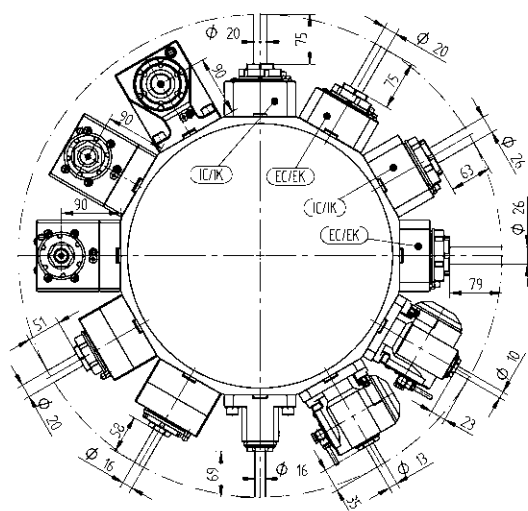

Porte-outils entraînés - Programme élargi



Porte-outil de fraisage radial avec arbre porte-fraise DIN 6358

Ø 16	410216000-60 00675000854	1:1	EC
Ø 22	410222007-60 T32268 00675000483	1:1	EC
Ø 27	410227008-60 00675000245	1:1	EC



Porte-outil d'alésage et de fraisage radial, décalé

ER-32 QF	420132019-60 0067732000	1:1	EC
ER-32 QF	420132020-60 0067732000	1:1	IC 80 bar
ER-25 QF	420125010-60 0067725001	1:2	EC
ER-25 QF	420125011-60 0067725001	1:2	IC 80 bar
ER-32 QF	420132021-60 0067732000	2:1	EC
ER-32 QF	420132022-60 0067732000	2:1	IC 80 bar



Porte-outil d'alésage et de fraisage axial

ER-25 QF	QF25-DNI-MS60A-090-E-S-A 0067725001	1:2	EC
ER-25 QF	QF25-DNI-MS60A-090-I-S-A 0067725001	1:2	IC 100 bar
ER-40 QF	420540014-60 0067740000	2:1	EC
ER-40 QF	420540015-60 0067740000	2:1	IC 80 bar

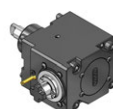

Porte-outil de fraisage axial avec arbre porte-fraise DIN 6358

Ø 22	M022-DNI-MS60A-090-E-T-A 00675000483	2:1	EC
Ø 27	M027-DNI-MS60A-090-E-T-A 00675000245	2:1	EC



Porte-outil d'alésage et de fraisage à angle réglable

ER 20	411013009-60 T32474 00675000928	1:1	EC
ER 20	411013010-60 00675000928	1:1	IC 80 bar
ER 16	411010001-60 00675000936	1:2	EC
ER 16	411010002-60 00675000936	1:2	IC 80 bar

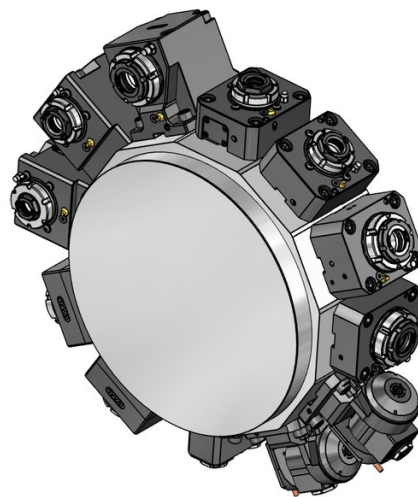
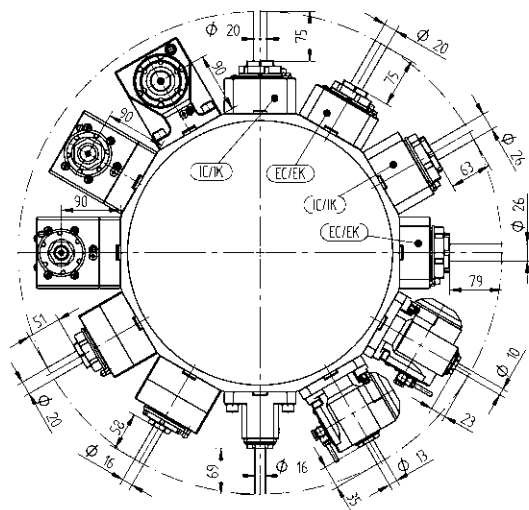

Porte-outils entraînés - Programme élargi



Porte-outil d'alésage et de fraisage radial, deux côtés

ER 25

413002001-60

1:1 EC

00675000907

Douilles de réduction standard - cylindriques

Douilles de réduction standard - cylindriques, fendues



Douille de réduction Ø 20

240020006	ø 6
240020008	ø 8
240020010	ø 10
240020012	ø 12
240020014	ø 14
240020016	ø 16



Douille de réduction Ø 25

240025006	ø 6
240025008	ø 8
240025010	ø 10
240025012	ø 12
240025014	ø 14
240025016	ø 16
240025020	ø 20



Douille de réduction Ø 32

240032006	ø 6
240032008	ø 8
240032010	ø 10
240032012	ø 12
240032014	ø 14
240032016	ø 16
240032018	ø 18
240032020	ø 20
240032025	ø 25



Douille de réduction Ø 40

240040006	ø 6
240040008	ø 8
240040010	ø 10
240040012	ø 12
240040014	ø 14
240040016	ø 16
240040020	ø 20
240040025	ø 25
240040032	ø 32



Douille de réduction Ø 50

240050010	ø 10
240050012	ø 12
240050016	ø 16
240050020	ø 20
240050025	ø 25
240050032	ø 32
240050040	ø 40



Douille de réduction Ø 25

240125006	ø 6
240125008	ø 8
240125010	ø 10
240125012	ø 12
240125014	ø 14
240125015	ø 15
240125016	ø 16
240125020	ø 20

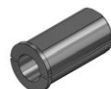

Douille de réduction Ø 32

240132008	ø 8
240132010	ø 10
240132012	ø 12
240132015	ø 15
240132016	ø 16
240132020	ø 20
240132025	ø 25



Douille de réduction Ø 40

240140010	ø 10
240140012	ø 12
240140015	ø 15
240140016	ø 16
240140020	ø 20
240140025	ø 25
240140032	ø 32



Douille de réduction Ø 50

240150020	ø 20
240150025	ø 25
240150032	ø 32
240150040	ø 40

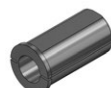

Douille de réduction Ø 60

240160032	ø 32
240160040	ø 40
240160050	ø 50

Douilles de réduction standard - cône morse

Douilles de réduction pour porte-barre d'alésage - cylindriques



Douille de réduction Ø 32

240532001	CM 1
240532002	CM 2
240532003	CM 3

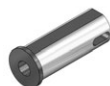

Douille de réduction Ø 40

240540001	CM 1
240540002	CM 2
240540003	CM 3
240540004	CM 4



Douille de réduction Ø 25

24-T20180	ø 8
24-T20182	ø 10
24-T20184	ø 12
24-T20186	ø 16
24-T20188	ø 20



Douille de réduction Ø 32

24-T20112	ø 8
24-T20114	ø 10
24-T20116	ø 12
24-T20118	ø 16
24-T20120	ø 20
24-T20122	ø 25



Douille de réduction Ø 40

24-T20086	ø 8
24-T20088	ø 10
24-T20090	ø 12
24-T20092	ø 16
24-T20094	ø 20
24-T20096	ø 25
24-T20098	ø 32



Douille de réduction Ø 50

24-T20160	ø 10
24-T20162	ø 12
24-T20164	ø 16
24-T20166	ø 20
24-T20168	ø 25
24-T20170	ø 32
24-T20172	ø 40



Douille de réduction Ø 60

24-T20136	ø 32
24-T20138	ø 40
24-T20140	ø 50

Douilles de réduction pour porte-barre d'alésage - cylindriques, allongées

Douilles de réduction pour porte-barre d'alésage - cône morse



Douille de réduction Ø 32

24-T20124	ø 8
24-T20126	ø 10
24-T20128	ø 12
24-T20130	ø 16



Douille de réduction Ø 40

24-T20106	ø 8
24-T20108	ø 10
24-T20110	ø 12
24-T20194	ø 16
24-T20196	ø 20
24-T20216	ø 25

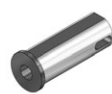

Douille de réduction Ø 40

24-T22046	CM 2
24-T22042	CM 3

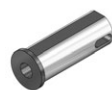

Douille de réduction Ø 50

24-T22044	CM 4
-----------	------

Pinces DIN 6499B (ER/ESX)



ER 11

190011000	∅ 7-0.5	∅ 0.276-0.020
190011010	∅ 1-0.5	∅ 0.039-0.020
190011015	∅ 1.5-1	∅ 0.059-0.039
190011020	∅ 2-1.5	∅ 0.079-0.059
190011025	∅ 2.5-2	∅ 0.098-0.079
190011030	∅ 3-2.5	∅ 0.118-0.098
190011035	∅ 3.5-3	∅ 0.138-0.118
190011040	∅ 4-3.5	∅ 0.158-0.138
190011045	∅ 4.5-4	∅ 0.177-0.158
190011050	∅ 5-4.5	∅ 0.197-0.177
190011055	∅ 5.5-5	∅ 0.217-0.197
190011060	∅ 6-5.5	∅ 0.236-0.217
190011065	∅ 6.5-6	∅ 0.256-0.236
190011070	∅ 7-6.5	∅ 0.276-0.256



ER 16

190016000	∅ 10-0.5	∅ 0.394-0.020
190016010	∅ 1-0.5	∅ 0.039-0.020
190016020	∅ 2-1	∅ 0.079-0.039
190016030	∅ 3-2	∅ 0.118-0.079
190016040	∅ 4-3	∅ 0.158-0.118
190016050	∅ 5-4	∅ 0.197-0.158
190016060	∅ 6-5	∅ 0.236-0.197
190016070	∅ 7-6	∅ 0.276-0.236
190016080	∅ 8-7	∅ 0.315-0.276
190016090	∅ 9-8	∅ 0.354-0.315
190016100	∅ 10-9	∅ 0.394-0.354



ER 20

190020000	∅ 13-1	∅ 0.512-0.039
190020010	∅ 1-0.5	∅ 0.039-0.020
190020020	∅ 2-1	∅ 0.079-0.039
190020030	∅ 3-2	∅ 0.118-0.079
190020040	∅ 4-3	∅ 0.157-0.118
190020050	∅ 5-4	∅ 0.197-0.157
190020060	∅ 6-5	∅ 0.236-0.197
190020070	∅ 7-6	∅ 0.276-0.236
190020080	∅ 8-7	∅ 0.315-0.276
190020090	∅ 9-8	∅ 0.354-0.315
190020100	∅ 10-9	∅ 0.394-0.354
190020110	∅ 11-10	∅ 0.433-0.394
190020120	∅ 12-11	∅ 0.472-0.433
190020130	∅ 13-12	∅ 0.512-0.472

Pinces DIN 6499B (ER/ESX)



ER 25

190025000	∅ 16-1	∅ 0.630-0.039
190025010	∅ 1-0.5	∅ 0.039-0.020
190025020	∅ 2-1	∅ 0.079-0.039
190025030	∅ 3-2	∅ 0.118-0.079
190025040	∅ 4-3	∅ 0.157-0.118
190025050	∅ 5-4	∅ 0.197-0.157
190025060	∅ 6-5	∅ 0.236-0.197
190025070	∅ 7-6	∅ 0.276-0.236
190025080	∅ 8-7	∅ 0.315-0.276
190025090	∅ 9-8	∅ 0.354-0.315
190025100	∅ 10-9	∅ 0.394-0.354
190025110	∅ 11-10	∅ 0.433-0.394
190025120	∅ 12-11	∅ 0.472-0.433
190025130	∅ 13-12	∅ 0.512-0.472
190025140	∅ 14-13	∅ 0.551-0.512
190025150	∅ 15-14	∅ 0.591-0.551
190025160	∅ 16-15	∅ 0.630-0.591



ER 32

190032000	∅ 20-2	∅ 0.787-0.079
190032020	∅ 2-1	∅ 0.079-0.039
190032030	∅ 3-2	∅ 0.118-0.079
190032040	∅ 4-3	∅ 0.157-0.118
190032050	∅ 5-4	∅ 0.197-0.157
190032060	∅ 6-5	∅ 0.236-0.197
190032070	∅ 7-6	∅ 0.276-0.236
190032080	∅ 8-7	∅ 0.315-0.276
190032090	∅ 9-8	∅ 0.354-0.315
190032100	∅ 10-9	∅ 0.394-0.354
190032110	∅ 11-10	∅ 0.433-0.394
190032120	∅ 12-11	∅ 0.472-0.433
190032130	∅ 13-12	∅ 0.512-0.472
190032140	∅ 14-13	∅ 0.551-0.512
190032150	∅ 15-14	∅ 0.591-0.551
190032160	∅ 16-15	∅ 0.630-0.591
190032170	∅ 17-16	∅ 0.669-0.630
190032180	∅ 18-17	∅ 0.709-0.669
190032190	∅ 19-18	∅ 0.748-0.709
190032200	∅ 20-19	∅ 0.787-0.748

Pinces DIN 6499B (ER/ESX)



ER 40

190040000	ø 26-3	ø 1.024-0.118
190040030	ø 3-2	ø 0.118-0.079
190040040	ø 4-3	ø 0.157-0.118
190040050	ø 5-4	ø 0.197-0.157
190040060	ø 6-5	ø 0.236-0.197
190040070	ø 7-6	ø 0.276-0.236
190040080	ø 8-7	ø 0.315-0.276
190040090	ø 9-8	ø 0.354-0.315
190040100	ø 10-9	ø 0.394-0.354
190040110	ø 11-10	ø 0.433-0.394
190040120	ø 12-11	ø 0.472-0.433
190040130	ø 13-12	ø 0.512-0.472
190040140	ø 14-13	ø 0.551-0.512
190040150	ø 15-14	ø 0.591-0.551
190040160	ø 16-15	ø 0.630-0.591
190040170	ø 17-16	ø 0.669-0.630
190040180	ø 18-17	ø 0.709-0.669
190040190	ø 19-18	ø 0.748-0.709
190040200	ø 20-19	ø 0.787-0.748
190040210	ø 21-20	ø 0.827-0.787
190040220	ø 22-21	ø 0.866-0.827
190040230	ø 23-22	ø 0.906-0.866
190040240	ø 24-23	ø 0.945-0.906
190040250	ø 25-24	ø 0.984-0.945
190040260	ø 26-25	ø 1.024-0.984



ER 50

190050000	ø 34-10	ø 1.339-0.394
190050060	ø 6-4	ø 0.236-0.157
190050080	ø 8-6	ø 0.315-0.236
190050100	ø 10-8	ø 0.394-0.315
190050120	ø 12-10	ø 0.472-0.394
190050140	ø 14-12	ø 0.551-0.472
190050160	ø 16-14	ø 0.630-0.551
190050180	ø 18-16	ø 0.709-0.630
190050200	ø 20-18	ø 0.787-0.709
190050220	ø 22-20	ø 0.866-0.787
190050240	ø 24-22	ø 0.945-0.866
190050260	ø 26-24	ø 1.024-0.945
190050280	ø 28-26	ø 1.102-1.024
190050300	ø 30-28	ø 1.181-1.102
190050320	ø 32-30	ø 1.260-1.181
190050340	ø 32-30	ø 1.260-1.181

Pinces DIN 6499D (ER/ESX) - étanches, pour IC



ER 11

191011030	ø 3
191011040	ø 4
191011050	ø 5
191011060	ø 6



ER 16

191016000	ø 3-10
191016030	ø 3
191016040	ø 4
191016050	ø 5
191016060	ø 6
191016070	ø 7
191016080	ø 8
191016090	ø 9
191016100	ø 10



ER 20

191020000	ø 3-12
191020030	ø 3
191020040	ø 4
191020050	ø 5
191020060	ø 6
191020070	ø 7
191020080	ø 8
191020090	ø 9
191020100	ø 10
191020110	ø 11
191020120	ø 12



ER 25

191025000	ø 4-16
191025030	ø 3
191025040	ø 4
191025050	ø 5
191025060	ø 6
191025070	ø 7
191025080	ø 8
191025090	ø 9
191025100	ø 10
191025110	ø 11
191025120	ø 12
191025130	ø 13
191025140	ø 14
191025150	ø 15
191025160	ø 16

Pinces DIN 6499D (ER/ESX) - étanches,
pour IC**ER 32**

191032000	ø 4-20
191032030	ø 3
191032040	ø 4
191032050	ø 5
191032060	ø 6
191032070	ø 7
191032080	ø 8
191032090	ø 9
191032100	ø 10
191032110	ø 11
191032120	ø 12
191032130	ø 13
191032140	ø 14
191032150	ø 15
191032160	ø 16
191032170	ø 17
191032180	ø 18
191032190	ø 19
191032200	ø 20

**ER 40**

191040060	ø 6
191040080	ø 8
191040100	ø 10
191040120	ø 12
191040140	ø 14
191040160	ø 16
191040180	ø 18
191040200	ø 20
191040220	ø 22
191040250	ø 25

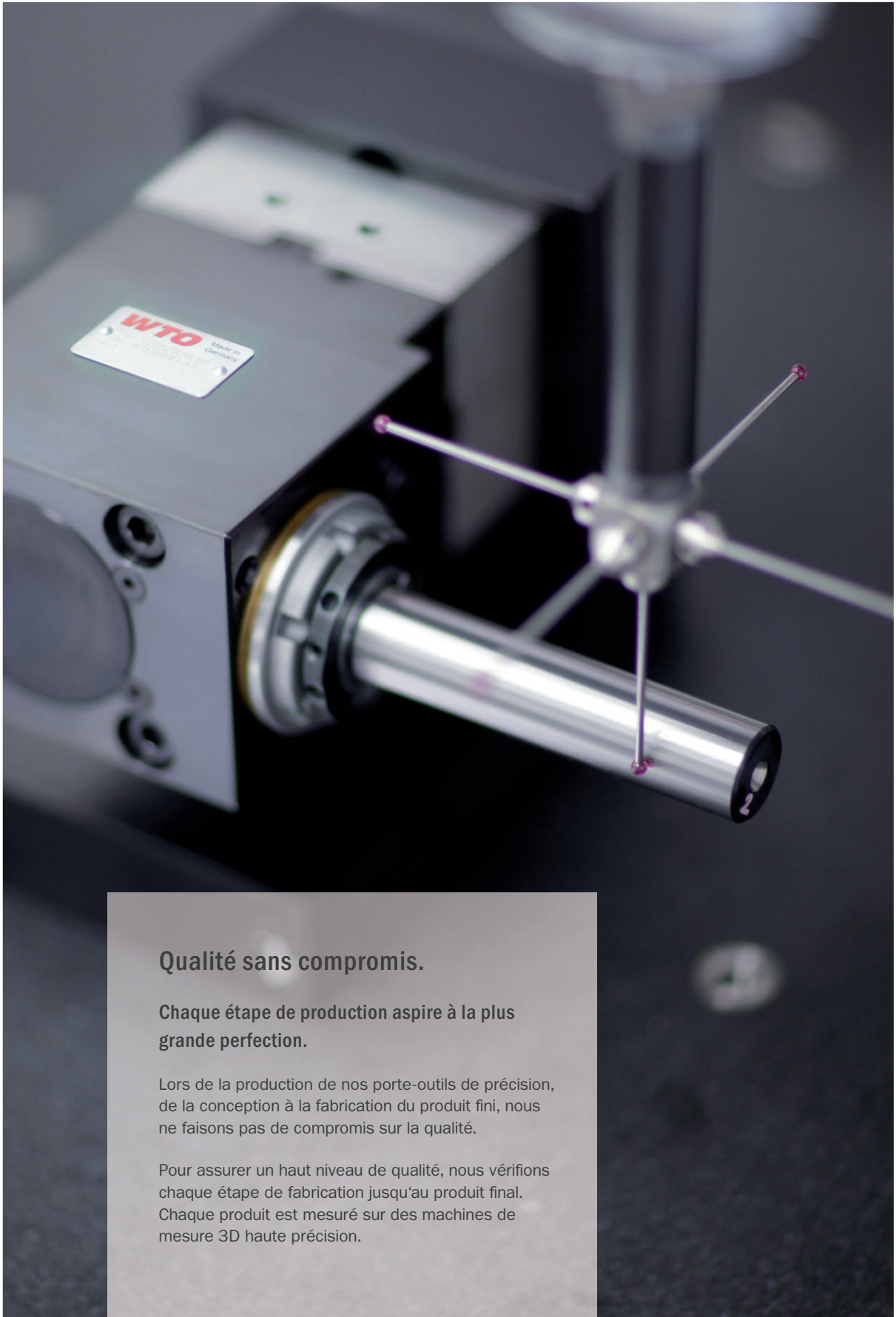

Qualité sans compromis.

Chaque étape de production aspire à la plus grande perfection.

Lors de la production de nos porte-outils de précision, de la conception à la fabrication du produit fini, nous ne faisons pas de compromis sur la qualité.

Pour assurer un haut niveau de qualité, nous vérifions chaque étape de fabrication jusqu'au produit final. Chaque produit est mesuré sur des machines de mesure 3D haute précision.

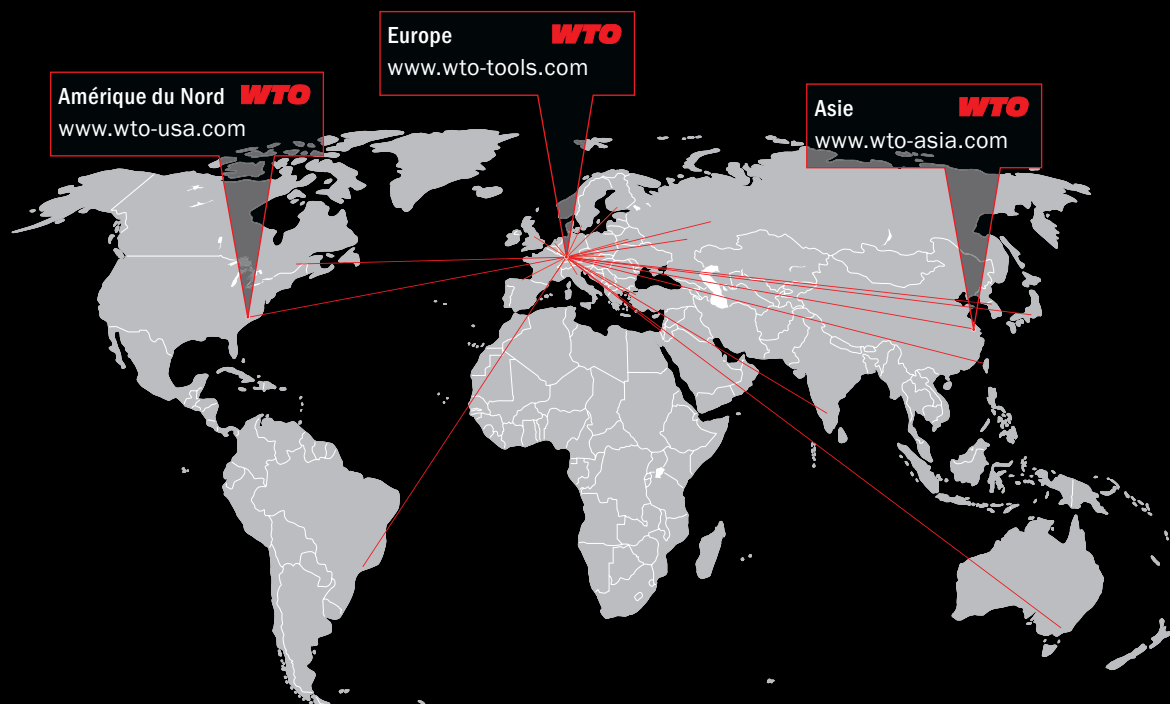

WTO Werkzeug-
Einrichtungen GmbH
Neuer Hohdammweg 1
77797 Ohlsbach
Allemagne

WTO Inc.
13900-F South Lakes Dr.
Charlotte, NC 28273
États-Unis

WTO Asia
WTO Precision Tool Holders
(Shanghai) Co. Ltd.
Room 109-110, Building 2
No. 228 Banting Road
Jiuting Town,
Songjiang District
201615 Shanghai
Chine

Partenaires de distribution – la compétence sur place

Australie
Dimac Tooling Ltd.
sales@dimac.com.au

Finlande
Suomen Terästuonti Oy
myynti@stt.as

Italie
Prymark srl
commerciale@prymark.it

Roumanie
SC Elif Trading SRL
bulent.ozkan@eliftrading.com

Brésil
TF2
tfdois@tfdois.com.br

France Est
Alexandre Mathelin
alm@wto.de

Japon
NK Works Co. Ltd.
k_samba@nk-works.co.jp

Suède
Bonthron & Ewing AB
info@bonthron-ewing.se

Canada
Mittmann Industrial Inc.
info@mittmann.com

France Ouest
Christophe Archambault
car@wto.de

Mexique
Workholding Engineering De México
info@wem.com.mx

Suisse
Utilis AG
info@utilis.com

Chine
Shanghai Gangde
wtocando@yahoo.com

Grande Bretagne
Cutwel Ltd.
sales@cutwel.net

Norvège
Helge Karlsen Verktøy og Maskin AS
hkvm@hkvm.no

Slovaquie
ALBA precision s.r.o.
albabprecision@albabprecision.sk

Corée
WTO Office Korea
is.chon@wto-korea.com

Hongrie
Prevotex Hungary Kft.
info@prevotex.hu

Pays-Bas
Toologic BeNeLux B.V.
info@toologic-benelux.nl

Taiwan
Kaiko Co., Ltd.
info@kaiko.com.tw

Danemark
AVN Teknik A/S
cjo@avn.dk

Inde
Ulhas Patil
u.patil@wto-asia.com

Pologne
ARCO Andrzej Rudenko
info@arcotools.pl

Turquie
MYK CNC MAKINA SAN. VE
huseyin.tatlidil@mykcnc.com.tr

Espagne
ITALMATIC, S.A.
italmatic@italmatic.es

Israël
E.Y.A.R. Ltd.
boris@eyar.co.il

République Tchèque
ALBA precision, spol. s.r.o.
info@albabprecision.cz

Ukraine
«LLC» SPA Stankopromimport
info@phoenix-ua.com