

Tool Holder Program

ALX 1500, 2000, 2500

NLX 2500 (static turret only)

NLX 1500, 2000, 2500, 3000

NLX 1500, 2000, 2500 (20 ST)

NLX 4000

NLX 6000

NTX 500 (BMT40)

NTX 500 (BMT42/64)

NTX 1000, 2000, 2500, 3000 Gen. 2 (BMT40)

NTX 2000, 2500, 3000 Gen. 2 (BMT60)

NT 4200, 4250, 4300, 5400

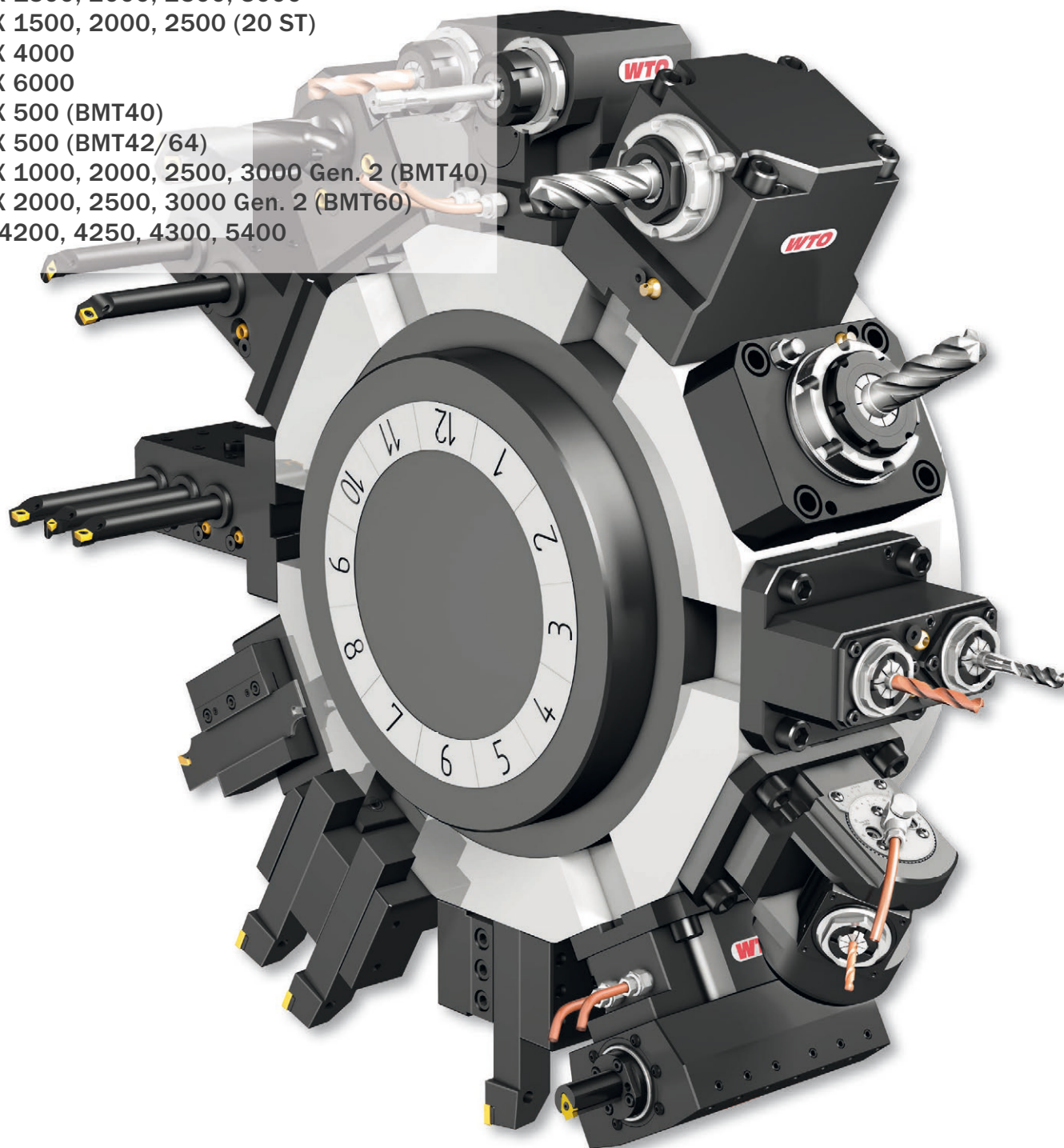

DMG MORI



QuickFlex®

The new quick change system for high performance and precision.

Minimal investment, maximal expandability.

Designed
for



ALX 1500, 2000, 2500	Page	4 - 10
NLX 2500 (static turret only)	Page	11 - 12
NLX 1500, 2000, 2500, 3000	Page	13 - 20
NLX 1500, 2000, 2500 (20 ST)	Page	21 - 27
NLX 4000	Page	28 - 35
NLX 6000	Page	36 - 38
NTX 500 (BMT40)	Page	39 - 45
NTX 500 (BMT42/64)	Page	46 - 47
NTX 1000,2000,2500,3000 Gen.2(BMT40)	Page	48 - 54
NTX 2000, 2500, 3000 Gen. 2 (BMT60)	Page	55 - 60
NT 4200, 4250, 4300, 5400	Page	61 - 66
Reduction sleeves	Page	67 - 70
Collets	Page	71 - 74

EC = External coolant supply
HP-IC = High pressure internal coolant supply through cutting tool
IC 80 bar = Internal and external coolant supply
 Max. coolant pressure = 80 bar
IC 30 bar = Internal and external coolant supply
 Max. coolant pressure = 30 bar
 Only use filtered coolant fluid (max. particle size = 50 µm)
 Do not run without coolant
 Do not use for machining abrasive materials such as cast iron, etc.

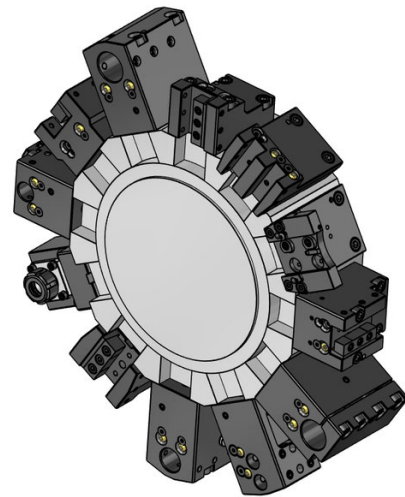
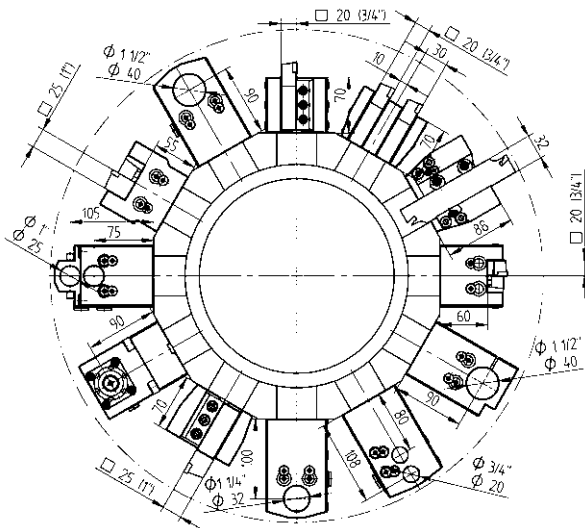

Static Toolholders - Standard Program

Static Toolholders - Standard Program



20	OD cutting holder, short	48-T00224 T00224
25		48-T00267 T00267
3/4"		48-T00234 T00234
1"		48-T00272 T00272



20	OD cutting holder, short, HP-IC	48-T00224-HP T00224	IC 80 bar
25		48-T00267-HP T00267	IC 80 bar
3/4"		48-T00234-HP T00234	IC 80 bar
1"		48-T00272-HP T00272	IC 80 bar



20	OD cutting holder, both sides, short	48-T00228 T00228
25		48-86523
3/4"		48-T00250 T00250
1"		48-86524



20	OD cutting holder, both sides, short, HP-IC	48-T00228-HP T00228	IC 80 bar
25		48-86523-HP	IC 80 bar
3/4"		48-T00250-HP T00250	IC 80 bar
1"		48-86524-HP	IC 80 bar



25	Face cutting holder	48-T03024 T03024
3/4"		48-T03018 T03018
1"		48-T03025 T03025



20	Face cutting holder, HP-IC	48-T03017-HP T03017	IC 80 bar
3/4"		48-T03018-HP T03018	IC 80 bar



20	Cut-off holder, right hand	48-T00251 T00251
25		48-T00268 T00268, T00356
3/4"		48-T00252 T00252
1"		48-T00359 T00359, T00357

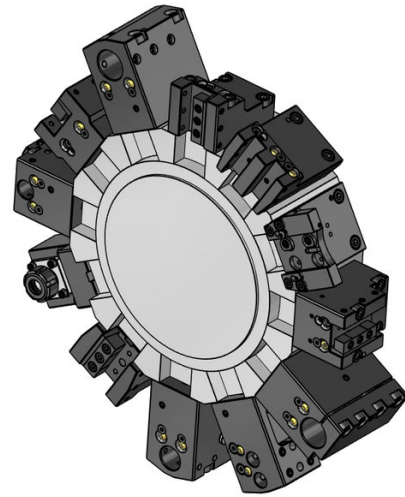
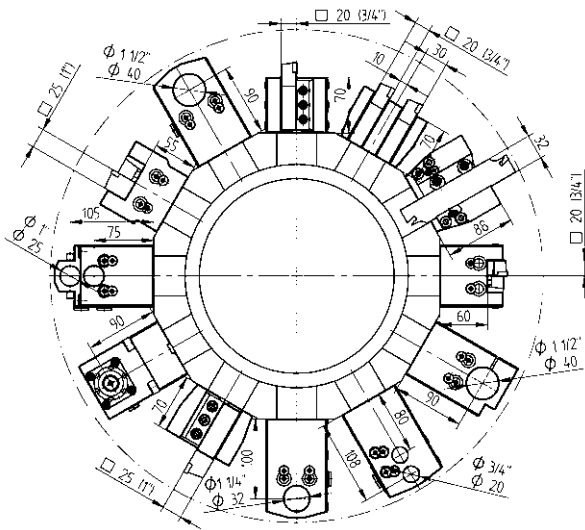

Static Toolholders - Standard Program



- Boring bar holder**
 Ø 32 48-T10115
 T10115
 Ø 1 1/4" 48-T10119
 T10119



- Combination toolholder**
 Ø 32 48-T13132 IC 80 bar
 T13132
 Ø 40 48-77999 IC 80 bar
 Ø 1 1/4" 48-T13135 IC 80 bar
 T13135
 Ø 1 1/2" 48-80016 IC 80 bar



- Boring bar holder, both sides**
 Ø 25 48-T10117
 T10117
 Ø 1" 48-T10139
 T10139

Static Toolholders - Enhanced Program



- OD cutting holder, double, Y axis**
 20 (3/4") 48-77726



- OD cutting holder, both sides, double, Y axis**
 20 (3/4") 48-77727



- Face cutting holder, both sides**
 20 48-79608
 3/4" 48-79609



- Cut-off holder, adjustable**
 SH 32 48-98891



- Cut-off holder, adjustable, HP-IC**
 SH 32 48-102261R IC 80 bar
 SH 32 48-102261L IC 80 bar



- Boring bar holder, with slot**
 Ø 32 48-82057
 Ø 40 48-82058
 Ø 1 1/4" 48-82059
 Ø 1 1/2" 48-82060

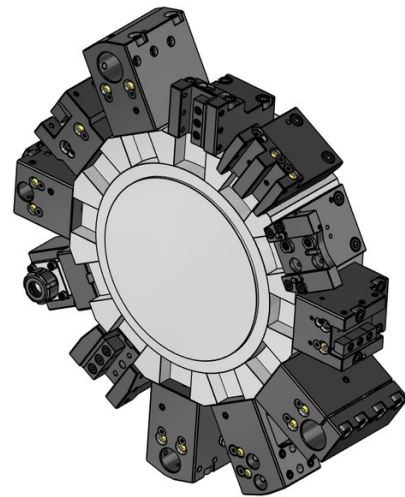
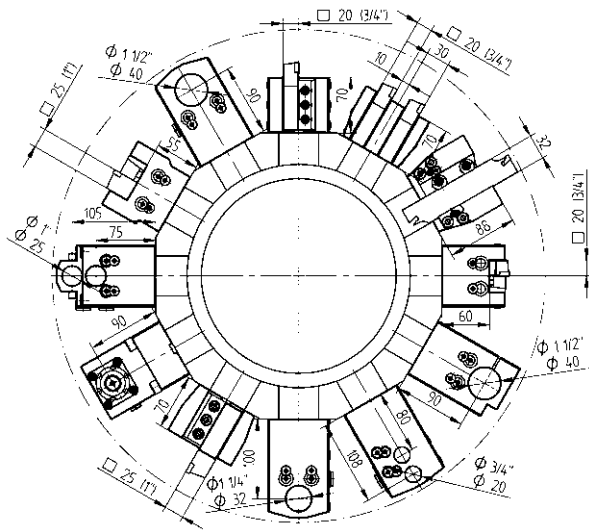

Static Toolholders - Enhanced Program



$\phi 20$
 $\phi 3/4"$

Boring bar holder, double, universal

48-75406
48-75416



ER 25

Collet face drill holder IC 80 bar

107525000

ER 32

48-81031 IC 80 bar

107532000



VDI 30

VDI adapter, left

48-77732



VDI 30

VDI adapter, right

48-78687



48-80506

Boring bar holder, blank

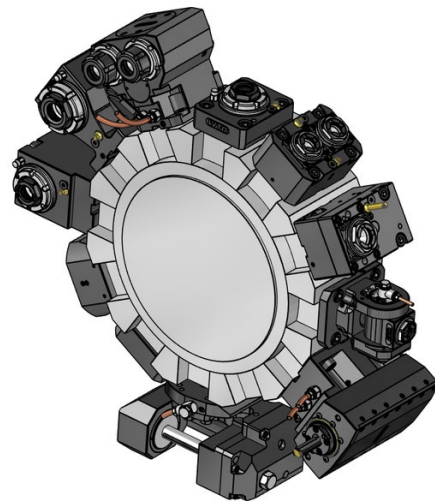
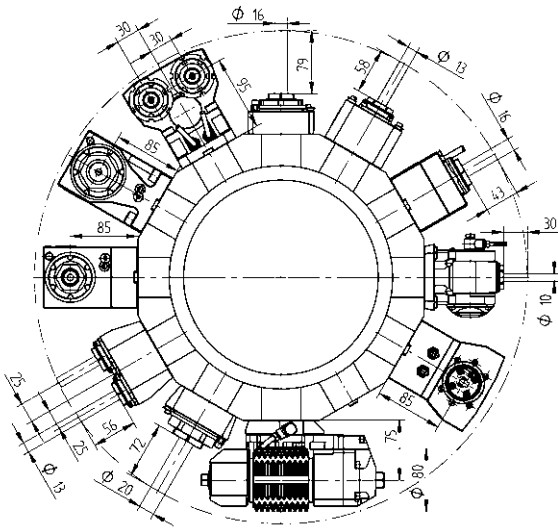

Driven Toolholders - QuickFlex®

Driven Toolholders - QuickFlex®



OD drill/milling unit (12000 RPM)

- ER-25 QF** 420125012-40 1:1 EC
T32433
0067725000
- ER-25 QF** 420125013-40 1:1 IC 80 bar
0067725000
- ER-32 QF** QF32-DNE-MS40A-050-E-HS-A 1:1 EC
0067732000
- ER-32 QF** QF32-DNE-MS40A-067-I-HS-A 1:1 IC 100 bar
0067732000



OD drill/milling unit (12000 RPM) - QF smart (EU, US, CA, JP)

- ER-32 QF** QF32-DNE-MS40A-067-I-HS-SB-A 1:1 IC 100 bar
0067732000
LI-F12-01



OD drill/milling unit (6000 RPM, Heavy Duty)

- ER-25 QF** 420125010-40 1:1 EC
T32274, T32450
0067725000
- ER-25 QF** 420125011-40 1:1 IC 80 bar
T32287
0067725000
- ER-32 QF** 420132010-40 1:1 EC
T32475, T32484
0067732000
- ER-32 QF** 420132011-40 1:1 IC 80 bar
0067732000



Face drill/milling unit (12000 RPM)

- ER-25 QF** 420525013-40 1:1 EC
T32434
0067725000
- ER-25 QF** 420525014-40 1:1 IC 80 bar
T32436
0067725000
- ER-32 QF** QF32-DNI-MS40A-085-E-HS-A 1:1 EC
0067732000
- ER-32 QF** QF32-DNI-MS40A-085-I-HS-A 1:1 IC 100 bar
0067732000



Face drill/milling unit (12000 RPM) - QF smart (EU, US, CA, JP)

- ER-32 QF** QF32-DNI-MS40A-085-I-HS-SB-A 1:1 IC 100 bar
0067732000
LI-F12-01



Face drill/milling unit (6000 RPM, Heavy Duty)

- ER-25 QF** 420525010-40 1:1 EC
T32275, T32297
0067725000
- ER-25 QF** 420525011-40 1:1 IC 80 bar
T32288, T32435
0067725000
- ER-32 QF** 420532010-40 1:1 EC
T32476, T32485
0067732000

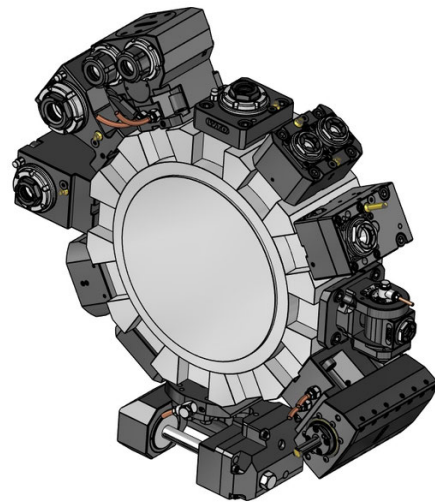
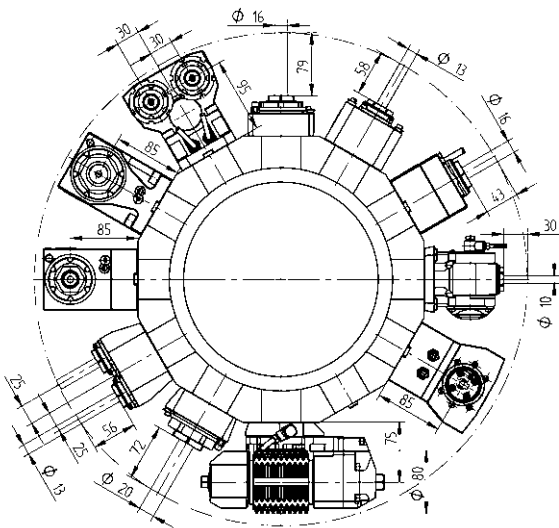

Driven Toolholders - QuickFlex®



Face drill/milling unit, both sides (12000 RPM)

- | | | | |
|-----------------|--------------|-----|----|
| ER-25 QF | 420525049-40 | 1:1 | EC |
| | 0067725000 | | |
| ER-32 QF | 420532148-40 | 1:1 | EC |
| | 0067732000 | | |



Face drill/milling unit, both sides (6000 RPM, Heavy Duty)

- | | | | |
|-----------------|----------------|-----|----|
| ER-25 QF | 420525012-40 | 1:1 | EC |
| | T32276, T32437 | | |
| | 0067725000 | | |
| ER-32 QF | 420532012-40 | 1:1 | EC |
| | 0067732000 | | |

Driven Toolholders - Enhanced Program



OD milling unit with combination mill arbor DIN 6358

- | | | | |
|---------------|----------------|-----|----|
| Ø 16 | 410216010-40 | 1:1 | EC |
| | 00675000854 | | |
| Ø 22 | 410222016-40 | 1:1 | EC |
| | T32280, T32486 | | |
| | 00675000483 | | |
| Ø 3/4" | 410219003-40 | 1:1 | EC |
| | 00675000483 | | |



OD drill/milling unit, offset

- | | | | |
|--------------|--------------|-----|-----------|
| ER 25 | 410116050-40 | 1:1 | EC |
| | T32488 | | |
| | 00675000932 | | |
| ER 25 | 410116057-40 | 1:1 | IC 80 bar |
| | 00675000932 | | |
| ER 20 | 410113060-40 | 1:2 | EC |
| | 00675000939 | | |
| ER 20 | 410113068-40 | 1:2 | IC 80 bar |
| | 00675000939 | | |
| ER 16 | 410410003-40 | 1:3 | EC |
| | 00675000937 | | |
| ER 16 | 410410004-40 | 1:3 | IC 80 bar |
| | 00675000937 | | |
| ER 25 | 410116051-40 | 2:1 | EC |
| | 00675000932 | | |
| ER 25 | 410116058-40 | 2:1 | IC 80 bar |
| | 00675000932 | | |

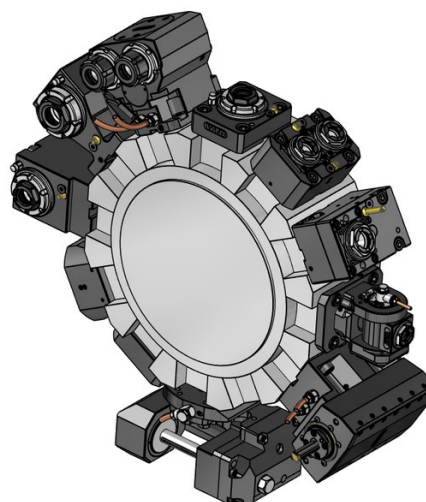
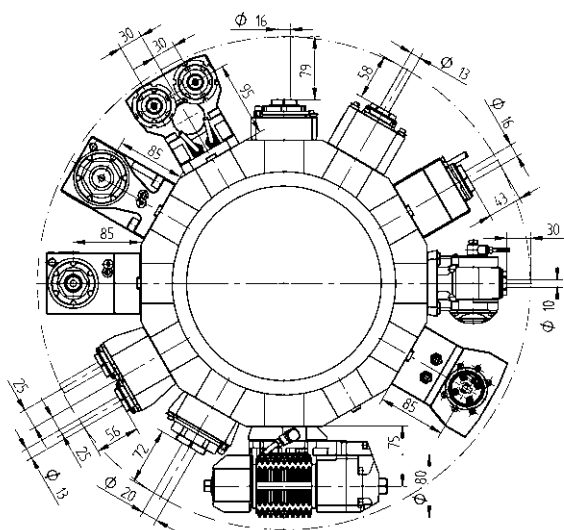

Driven Toolholders - Enhanced Program

Driven Toolholders - Enhanced Program



OD drill/milling unit, offset (12000 RPM)

- ER 25** 410116060-40 1:1 EC
 00675000932
- ER 25** 410116059-40 1:1 IC 80 bar
 00675000932



Face drill/milling unit

- ER-20 QF** 420520010-40 1:2 EC
 0067720001
- ER-20 QF** 420520011-40 1:2 IC 80 bar
 0067720001
- ER 16** 410810012-40 1:3 EC
 0067825001
- ER 16** 410810013-40 1:3 IC 80 bar
 0067825001
- ER-32 QF** 420532013-40 2:1 EC
 0067732000
- ER-32 QF** QF32-DNI-MS40A-085-I-T-A 2:1 IC 100 bar
 0067732000



**Face milling unit with combination mill arbor
DIN 6358**

- Ø 16** 410616013-40 1:1 EC
 00675000854
- Ø 22** 410622030-40 1:1 EC
 00675000483
- Ø 3/4"** 410619003-40 1:1 EC
 00675000483

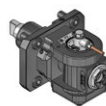

Adjustable angle drill/milling unit

- ER 16** 411010008-40 1:1 EC
 00675000913
- ER 16** 411010009-40 1:1 IC 80 bar
 00675000913
- ER 11** 411007001-40 1:2 EC
 00675000914
- ER 11** 411007002-40 1:2 IC 80 bar
 00675000914



Gear hobbing unit

- Type 16-1** 411500017-40 1:1 EC
- Type 16-1** 411500018-40 2:1 EC
 00675000954
- 160016161 Ø 16
- 160022161 Ø 22
- 160027161 Ø 27
- 160015161 Ø 5/8"
- 160019161 Ø 3/4"
- 160025161 Ø 1"
- 160031161 Ø 1 1/4"
- 110587

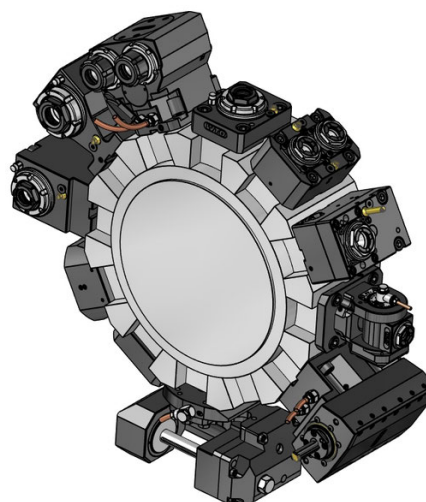
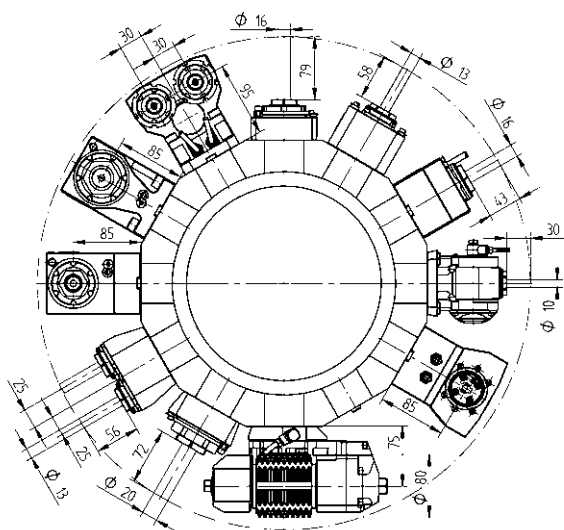

Driven Toolholders - Enhanced Program

Driven Toolholders - Enhanced Program



- OD drill/milling unit, both sides**
- ER 20 413002015-40 1:1 EC
 00675000947
- ER 20 413002018-40 1:1 IC 80 bar
 00675000947

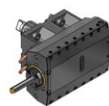

- Broaching unit for ID and OD**
- Type 52 414552002-40 1:1 EC



- OD drill/milling unit, double, Y axis**
- ER 20 413002014-40 1:1 EC
 00675000947
- ER 20 413002017-40 1:1 IC 80 bar
 00675000947

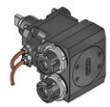

- 2-spindle - Face drill/milling unit, Y axis**
- ER 25 413502008-40 1:1 EC
 00675000915
- ER 25 413502009-40 1:1 IC 80 bar
 00675000915



- 2-spindle - Face drill/milling unit, both sides, Y axis**
- ER 25 413502007-40 1:1 EC
 00675000915



- Broaching unit for ID and OD**
- Type 32 414532000-40 1:1 EC

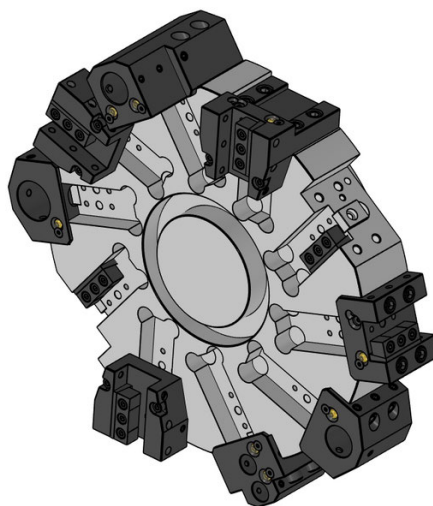
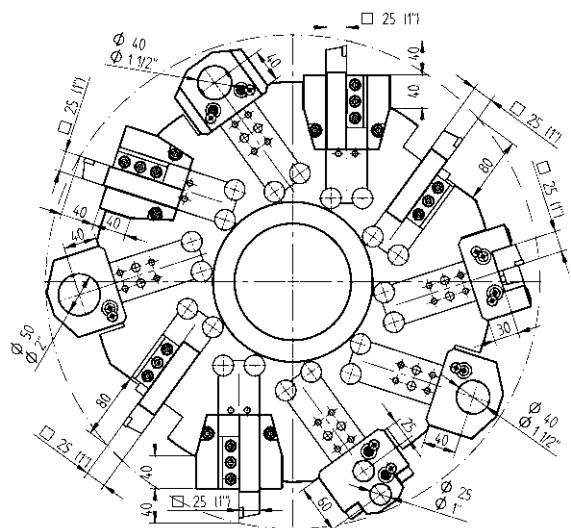

Static Toolholders - Standard Program

Static Toolholders - Standard Program



Wedge block
25(1") 48-B27036

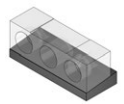

Wedge shim
25 48-B27037
1" 48-B27038



OD cutting holder
25 48-T00074
1" 48-T00075



Face cutting holder
25 48-T00068
1" 48-T00069



Boring bar holder
Ø 40 48-T10036
Ø 50 48-T10044
Ø 1 1/2" 48-T10037
Ø 2" 48-T10045



Combination toolholder
Ø 40 48-T13064 IC 80 bar
Ø 50 48-83292 IC 80 bar
Ø 1 1/2" 48-T13065 IC 80 bar
Ø 2" 48-83294 IC 80 bar



Combination toolholder, extended
Ø 40 48-T10038 IC 80 bar
Ø 1 1/2" 48-T10039 IC 80 bar

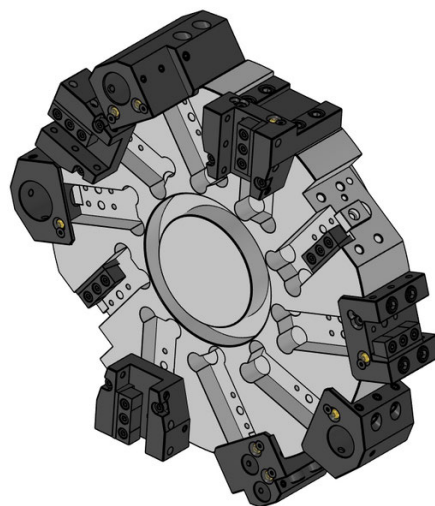
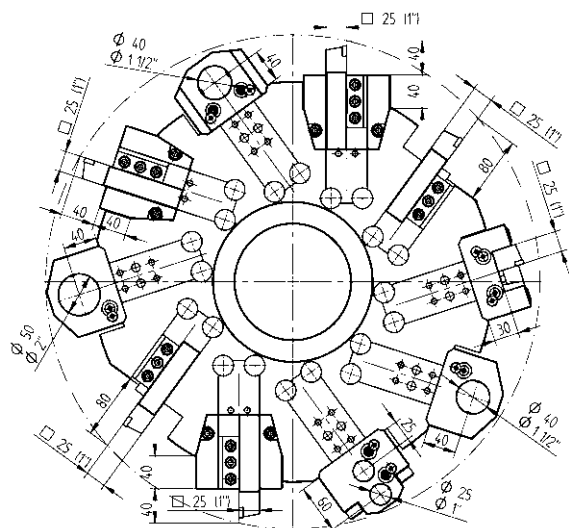

Static Toolholders - Enhanced Program



Work stopper

48-T17002



OD cutting holder, HP-IC

25 48-T00074-HP IC 80 bar



Face cutting holder, HP-IC

25 48-T00068-HP IC 80 bar
1" 48-T00069-HP IC 80 bar



Boring bar holder, double

Ø 25 48-83452
Ø 1" 48-83592



VDI adapter, left

VDI 30 48-83473



VDI adapter, right

VDI 30 48-49950

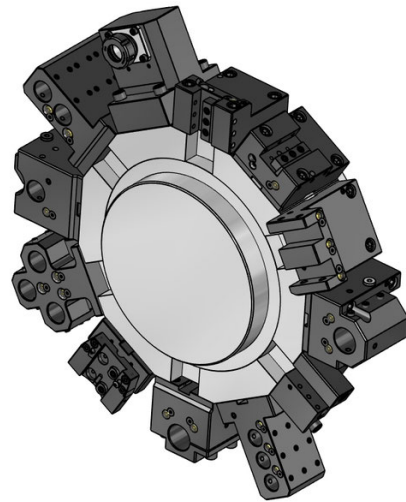
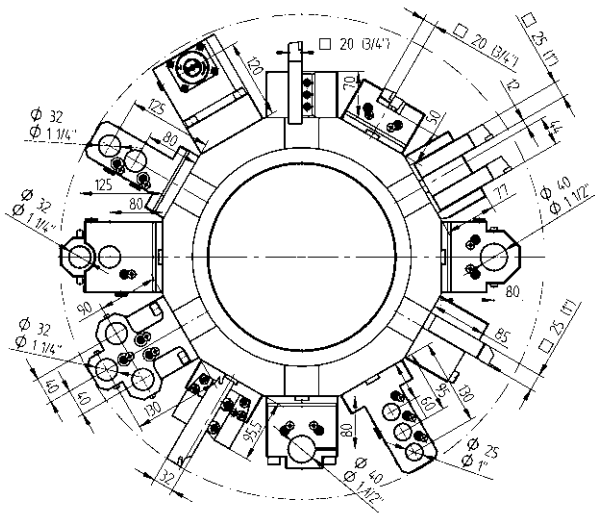

Static Toolholders - Standard Program

Static Toolholders - Standard Program



- OD cutting holder**
- 20 48-T00187
T00187
 - 25 48-T00186
T00186
 - 3/4" 48-T00203
T00203
 - 1" 48-T00202
T00202



- OD cutting holder, HP-IC**
- 25 48-T00186-HP IC 80 bar
T00186
 - 1" 48-T00202-HP IC 80 bar
T00202



- OD cutting holder, both sides**
- 20 48-T00185
T00185
 - 25 48-T00184
T00184
 - 3/4" 48-T00201
T00201
 - 1" 48-T00199
T00199



- OD cutting holder, both sides, HP-IC**
- 25 48-T00184-HP IC 80 bar
T00184
 - 1" 48-T00199-HP IC 80 bar
T00199



- Face cutting holder**
- 20 48-T03006
T03006
 - 25 48-T03005
T03005
 - 3/4" 48-T03014
T03014
 - 1" 48-T03013
T03013



- Face cutting holder, HP-IC**
- 25 48-T03005-HP IC 80 bar
T03005
 - 1" 48-T03013-HP IC 80 bar
T03013



- Cut-off holder, right hand**
- 25 48-T00197
T00197
 - 1" 48-T00198
T00198



- Boring bar holder, LF=80**
- Ø 40 48-T10097
T10097
 - Ø 50 48-T10098
T10098
 - Ø 1 1/2" 48-T10101
T10101
 - Ø 2" 48-T10102
T10102
 - Ø 2 1/2" 48-70080

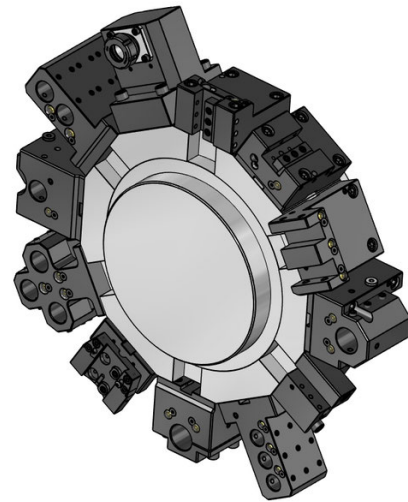
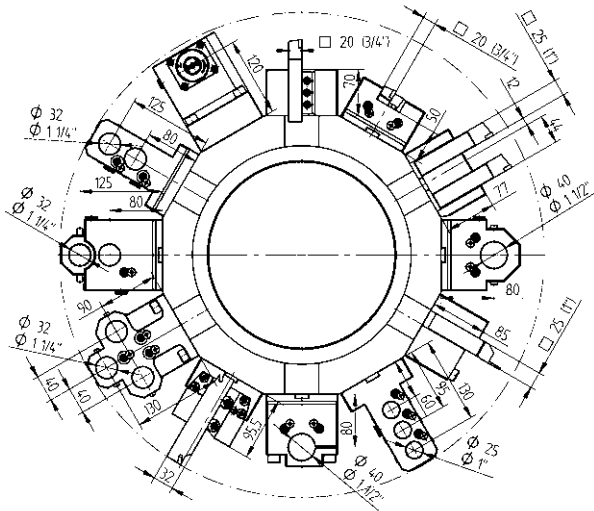

Static Toolholders - Standard Program



Boring bar holder, LF=120

- Ø 40 48-T10113
T10113
- Ø 50 48-T10114
T10114
- Ø 1 1/2" 48-T10134
T10134
- Ø 2" 48-T10135
T10135



Combination toolholder, LF=80

- Ø 40 48-T13128 IC 80 bar
T13128
- Ø 50 48-T13139 IC 80 bar
T13139
- Ø 1 1/2" 48-T13130 IC 80 bar
T13130
- Ø 2" 48-T13140 IC 80 bar
T13140



Combination toolholder, LF=120

- Ø 40 48-T13131 IC 80 bar
T13131
- Ø 50 48-77902 IC 80 bar
- Ø 1 1/2" 48-T13137 IC 80 bar
T13137
- Ø 2" 48-77901 IC 80 bar

Static Toolholders - Standard Program



Boring bar holder, both sides

- Ø 32 48-T10096
T10096
- Ø 1 1/4" 48-T10100
T10100
- Ø 1 1/2" 48-89192



Combination toolholder, both sides

- Ø 40 48-89027 IC 80 bar
- Ø 1 1/2" 48-89195 IC 80 bar

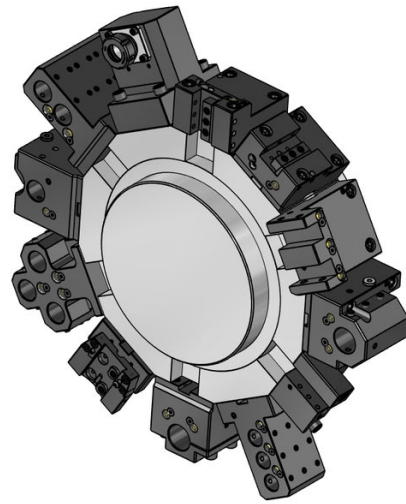
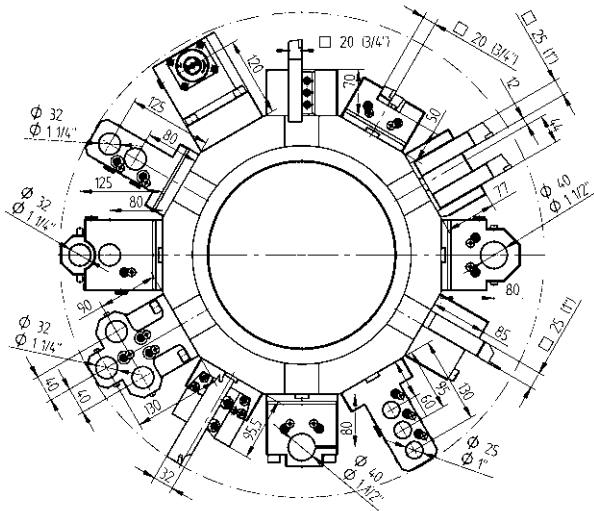

Static Toolholders - Enhanced Program



OD cutting holder, right hand, long, HP-IC
25 48-T00385-HP IC 80 bar
 T00385
1" 48-T00386-HP IC 80 bar
 T00386



OD cutting holder, left hand, long, HP-IC
25 48-T00387-HP IC 80 bar
 T00387
1" 48-T00388-HP IC 80 bar
 T00388



OD cutting holder, short
25 48-79591
1" 48-79593



OD cutting holder, extended
25 48-T00236
 T00236
1" 48-T00245
 T00245



OD cutting holder, double, Y axis
25(1") 48-71865
 T00206, T00210

Static Toolholders - Enhanced Program

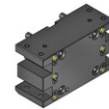

OD cutting holder, both sides, double, Y axis
25(1") 48-71863
 T00253, T00258



Face cutting holder, extended
25 48-T03019
 T03019
32 48-113046
1" 48-T03020
 T03020
1 1/4" 48-112853



Face cutting holder, both sides
25 48-78995
1" 48-78996



Cut-off holder, adjustable
SH 32 48-98901



Cut-off holder, adjustable, HP-IC
SH 32 48-102262R IC 80 bar
SH 32 48-102262L IC 80 bar



Cut-off holder, adjustable, extended
SH 32 48-77478

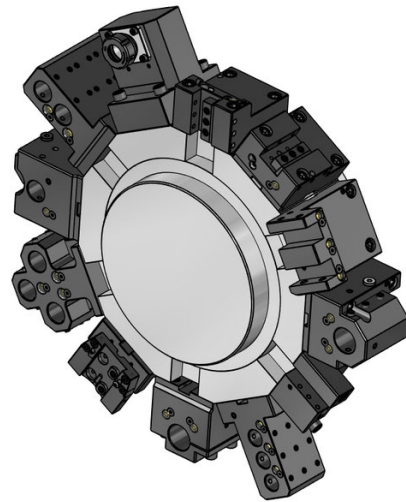
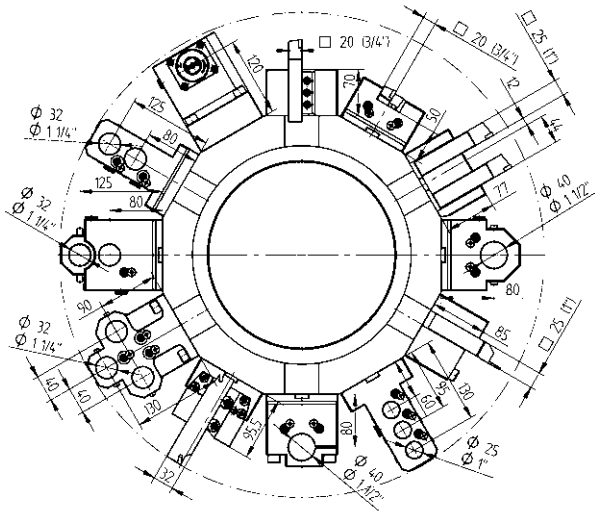

Static Toolholders - Enhanced Program



- Boring bar holder, with slot**
- Ø 40 48-T10136
T10136
 - Ø 50 48-T10137
T10137
 - Ø 60 48-70811
 - Ø 1 1/2" 48-T10143
T10143
 - Ø 2" 48-T10142
T10142



- Boring bar holder, triple, universal**
- Ø 25 48-T10104
T10104
 - Ø 1" 48-T10107
T10107



- Boring bar holder, double, both sides**
- Ø 32 48-71889
 - Ø 1 1/4" 48-72951

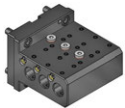

- Boring bar holder, triple, both sides**
- Ø 25 48-71875
 - Ø 1" 48-72949



- Boring bar holder, triple, both sides, Y axis**
- Ø 32 48-85932
 - Ø 1 1/4" 48-101078

Static Toolholders - Enhanced Program



- Collet face drill holder**
- ER 32 48-94564 IC 80 bar
107532000
 - ER 40 48-94566 IC 80 bar
107540000



- Collet face drill holder, both sides**
- ER 32 48-94565 IC 80 bar
107532000
 - ER 40 48-94567 IC 80 bar
107540000



- VDI adapter, left**
- VDI 30 48-77127
 - VDI 40 48-72984



- VDI adapter, right**
- VDI 30 48-74796
 - VDI 40 48-77955



- Boring bar holder, blank**
- 48-81080

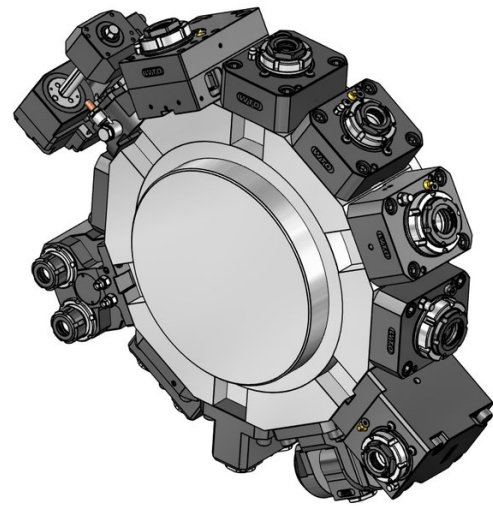
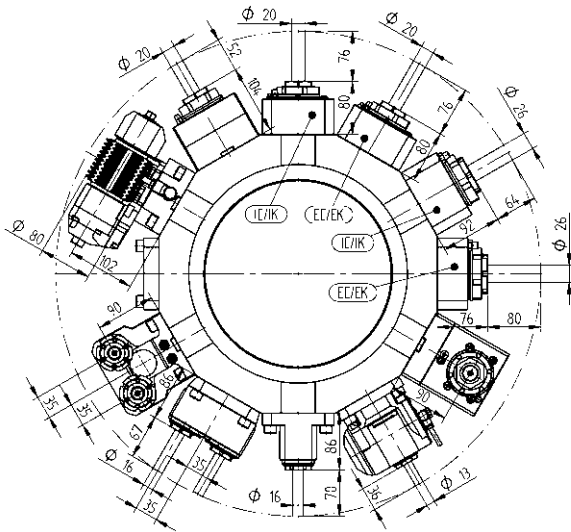

Driven Toolholders - QuickFlex®



OD drill/milling unit (12000 RPM)

- ER-32 QF** QF32-DNE-MS60A-072-E-HS-A 1:1 EC
0067732000
- ER-32 QF** QF32-DNE-MS60A-072-I-HS-A 1:1 IC 100 bar
0067732000



OD drill/milling unit (12000 RPM) - QF smart (EU, US, CA, JP)

- ER-32 QF** QF32-DNE-MS60A-072-I-HS-SB-A 1:1 IC 100 bar
0067732000
- LI-F12-01



OD drill/milling unit (6000 RPM, Heavy Duty)

- ER-32 QF** 420132011-60 T32232, T32478 1:1 IC 80 bar
0067732000
- ER-40 QF** 420140010-60 T32213 1:1 EC
0067740000
- ER-40 QF** 420140011-60 T32234 1:1 IC 80 bar
0067740000



Face drill/milling unit (12000 RPM)

- ER-32 QF** QF32-DNI-MS60A-090-E-HS-A 1:1 EC
0067732000
- ER-32 QF** QF32-DNI-MS60A-090-I-HS-A 1:1 IC 100 bar
0067732000

Driven Toolholders - QuickFlex®



Face drill/milling unit (12000 RPM) - QF smart (EU, US, CA, JP)

- ER-32 QF** QF32-DNI-MS60A-090-I-HS-SB-A 1:1 IC 100 bar
0067732000
- LI-F12-01



Face drill/milling unit (6000 RPM, Heavy Duty)

- ER-40 QF** 420540012-60 T32214 1:1 EC
0067740000
- ER-40 QF** 420540013-60 T32235 1:1 IC 80 bar
0067740000



Face drill/milling unit, both sides (10000 RPM)

- ER-32 QF** 420532041-60 1:1 EC
0067732000



Face drill/milling unit, both sides (6000 RPM, Heavy Duty)

- ER-32 QF** 420532019-60 T32216 1:1 EC
0067732000
- ER-40 QF** 420540016-60 T32248 1:1 EC
0067740000

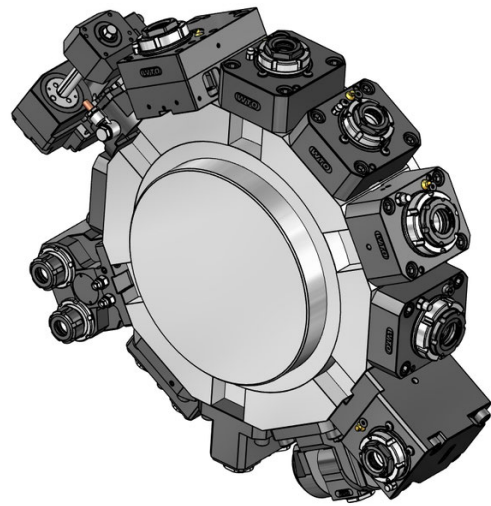
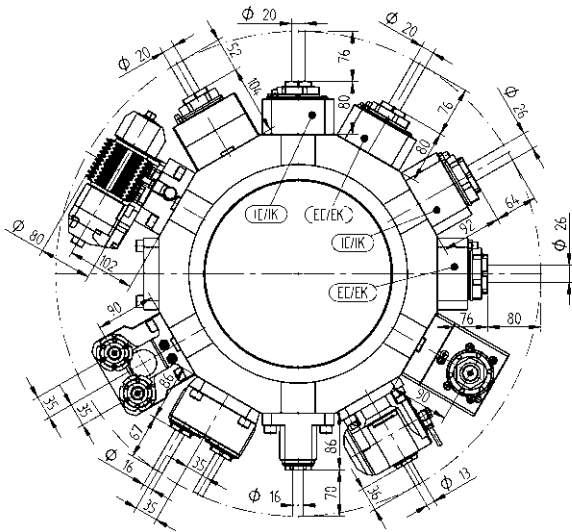

Driven Toolholders - Enhanced Program



**OD milling unit with combination mill arbor
DIN 6358**

Ø 16	410216000-60 00675000854	1:1	EC
Ø 22	410222007-60 T32268 00675000483	1:1	EC
Ø 27	410227008-60 00675000245	1:1	EC
Ø 3/4"	410219000-60 00675000483	1:1	EC
Ø 1"	410225000-60 T32217 00675000483	1:1	EC



OD drill/milling unit, offset

ER-32 QF	420132019-60 0067732000	1:1	EC
ER-32 QF	420132020-60 0067732000	1:1	IC 80 bar
ER-25 QF	420125010-60 0067725001	1:2	EC
ER-25 QF	420125011-60 0067725001	1:2	IC 80 bar
ER-32 QF	420132021-60 0067732000	2:1	EC
ER-32 QF	420132022-60 0067732000	2:1	IC 80 bar

Driven Toolholders - Enhanced Program



Face drill/milling unit

ER-25 QF	QF25-DNI-MS60A-090-E-S-A 0067725001	1:2	EC
ER-25 QF	QF25-DNI-MS60A-090-I-S-A 0067725001	1:2	IC 100 bar
ER-40 QF	420540014-60 0067740000	2:1	EC
ER-40 QF	420540015-60 0067740000	2:1	IC 80 bar

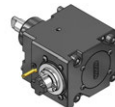

**Face milling unit with combination mill arbor
DIN 6358**

Ø 22	M022-DNI-MS60A-090-E-T-A 00675000483	2:1	EC
Ø 27	M027-DNI-MS60A-090-E-T-A 00675000245	2:1	EC
Ø 1"	M100-DNI-MS60A-090-E-T-A 00675000483	2:1	EC



Adjustable angle drill/milling unit

ER 20	411013009-60 T32474 00675000928	1:1	EC
ER 20	411013010-60 00675000928	1:1	IC 80 bar
ER 16	411010001-60 00675000936	1:2	EC
ER 16	411010002-60 00675000936	1:2	IC 80 bar

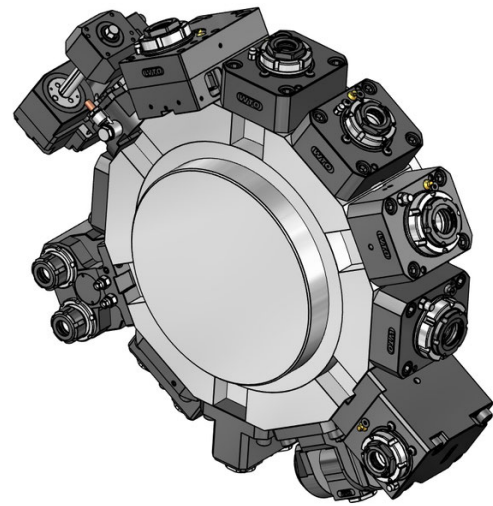
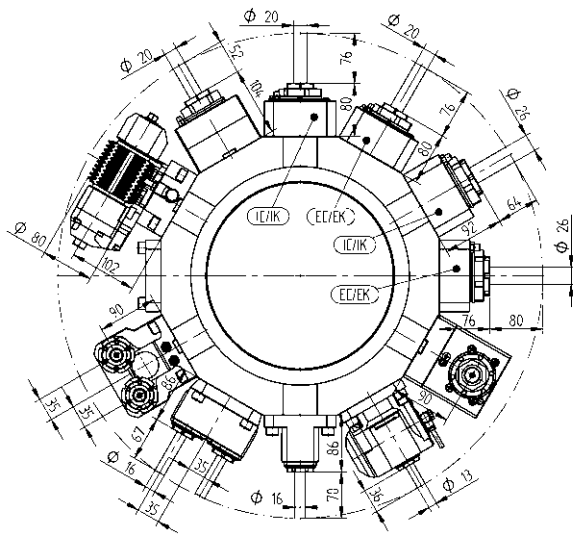

Driven Toolholders - Enhanced Program

Driven Toolholders - Enhanced Program



- Slitting saw unit**
- Type 19-2 411500006-60 3:1 EC
 00675000855
 160022192 Ø 22
 160027192 Ø 27
 160032192 Ø 32
 160040192 Ø 40
 160023192 Ø 7/8"
 160025192 Ø 1"
 160031192 Ø 1 1/4"
 160038192 Ø 1 1/2"



- OD drill/milling unit, both sides**
- ER 25 413002001-60 1:1 EC
 00675000907



- OD drill/milling unit, double, Y axis**
- ER 25 413002000-60 1:1 EC
 T32267
 00675000907
- ER 25 413002012-60 1:1 IC 80 bar
 00675000907



- Gear hobbing unit**
- Type 16-1 411500007-60 1:1 EC
 Type 16-1 411500008-60 2:1 EC
 00675000926
 160016161 Ø 16
 160022161 Ø 22
 160027161 Ø 27
 160015161 Ø 5/8"
 160019161 Ø 3/4"
 160025161 Ø 1"
 160031161 Ø 1 1/4"
 110587

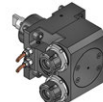

- 2-spindle - Face drill/milling unit, Y axis**
- ER 25 413502000-60 1:1 EC
 T32264
 00675000915
- ER 25 413502002-60 1:1 IC 80 bar
 00675000915

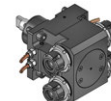

- 2-spindle - Face drill/milling unit, both sides, Y axis**
- ER 25 413502001-60 1:1 EC
 00675000915



- 4-spindle - Face drill/milling unit, both sides**
- ER 20 413504000-60 1:1 EC
 00675000974

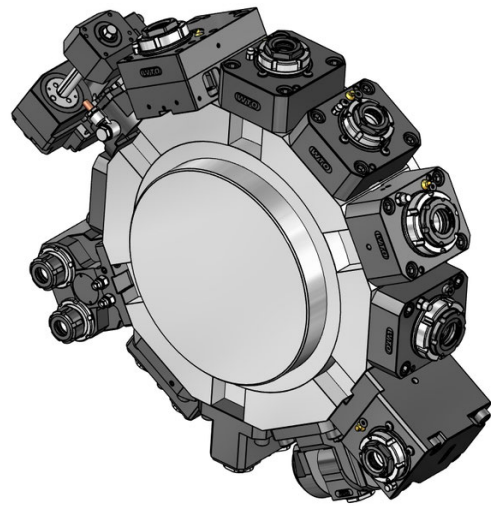
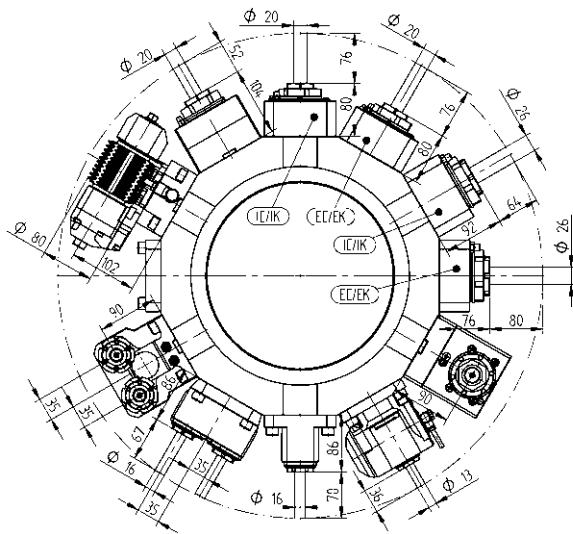

Driven Toolholders - Enhanced Program

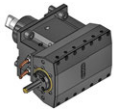

Broaching unit for ID and OD

Type 32	414532000-60	1:1	EC
Type 52	414552000-60	1:1	EC



Power Skiving Unit

Hydraulic	414920000-60	1:1	EC
	106445		

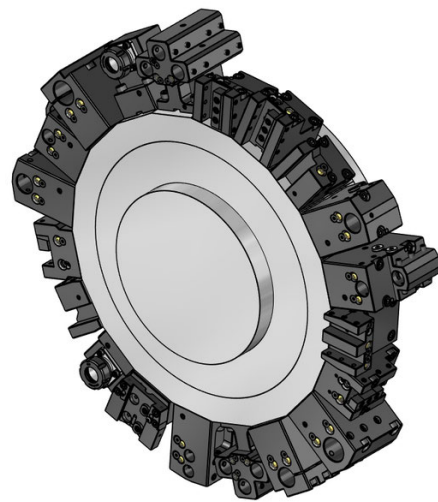
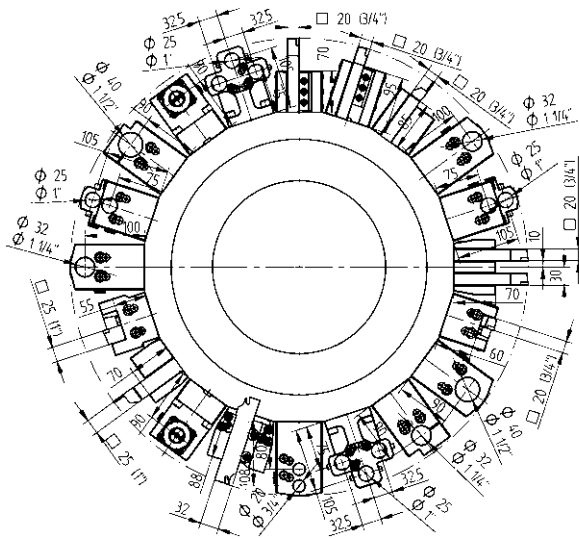

Static Toolholders - Standard Program

Static Toolholders - Standard Program



- OD cutting holder, short**
- 20 48-T00224
T00224
 - 25 48-T00267
T00267
 - 3/4" 48-T00234
T00234
 - 1" 48-T00272
T00272



- OD cutting holder, both sides, short, HP-IC**
- 20 48-T00228-HP IC 80 bar
T00228
 - 25 48-86523-HP IC 80 bar
 - 3/4" 48-T00250-HP IC 80 bar
T00250
 - 1" 48-86524-HP IC 80 bar



- OD cutting holder, short, HP-IC**
- 20 48-T00224-HP IC 80 bar
T00224
 - 25 48-T00267-HP IC 80 bar
T00267
 - 3/4" 48-T00234-HP IC 80 bar
T00234
 - 1" 48-T00272-HP IC 80 bar
T00272



- OD cutting holder, both sides, long**
- 20 48-T00226
T00226
 - 3/4" 48-T00249
T00249



- OD cutting holder, long**
- 20 48-T00225
T00225
 - 3/4" 48-T00235
T00235



- Face cutting holder**
- 25 48-T03024
T03024
 - 3/4" 48-T03018
T03018
 - 1" 48-T03025
T03025



- OD cutting holder, both sides, short**
- 20 48-T00228
T00228
 - 25 48-86523
 - 3/4" 48-T00250
T00250
 - 1" 48-86524



- Face cutting holder, HP-IC**
- 20 48-T03017-HP IC 80 bar
T03017
 - 3/4" 48-T03018-HP IC 80 bar
T03018

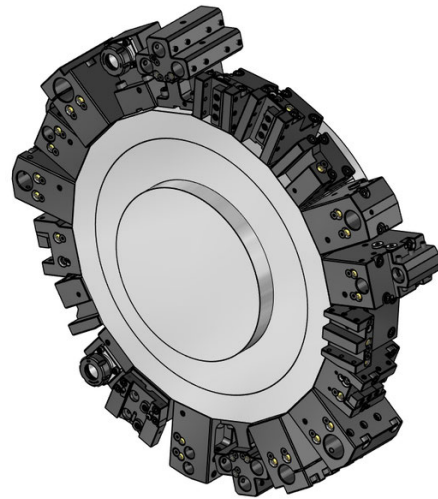
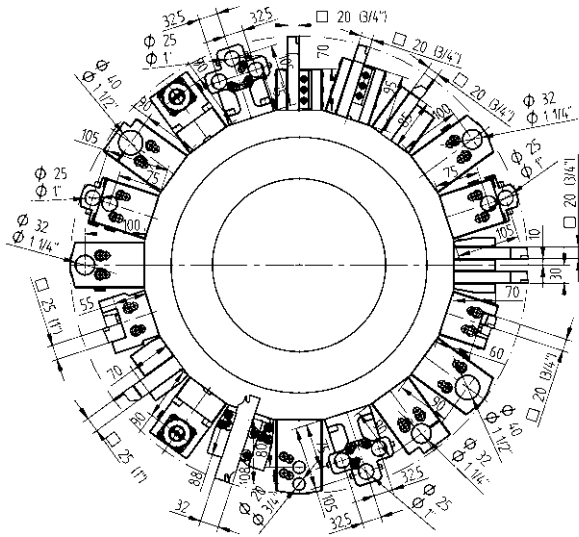

Static Toolholders - Standard Program



- Cut-off holder, right hand**
- 20 48-T00251
T00251
 - 25 48-T00268
T00268, T00356
 - 3/4" 48-T00252
T00252
 - 1" 48-T00359
T00359, T00357



- Boring bar holder**
- Ø 32 48-T10115
T10115
 - Ø 1 1/4" 48-T10119
T10119



- Combination toolholder**
- Ø 32 48-T13132 IC 80 bar
T13132
 - Ø 40 48-77999 IC 80 bar
 - Ø 1 1/4" 48-T13135 IC 80 bar
T13135
 - Ø 1 1/2" 48-80016 IC 80 bar



- Boring bar holder, both sides**
- Ø 25 48-T10117
T10117
 - Ø 1" 48-T10139
T10139

Static Toolholders - Enhanced Program



- OD cutting holder, double, Y axis**
- 20 (3/4") 48-77726



- OD cutting holder, both sides, double, Y axis**
- 20 (3/4") 48-77727



- Face cutting holder, both sides**
- 20 48-79608
 - 3/4" 48-79609



- Cut-off holder, adjustable**
- SH 32 48-98891



- Cut-off holder, adjustable, HP-IC**
- SH 32 48-102261R IC 80 bar
 - SH 32 48-102261L IC 80 bar



- Boring bar holder, with slot**
- Ø 32 48-82057
 - Ø 40 48-82058
 - Ø 1 1/4" 48-82059
 - Ø 1 1/2" 48-82060

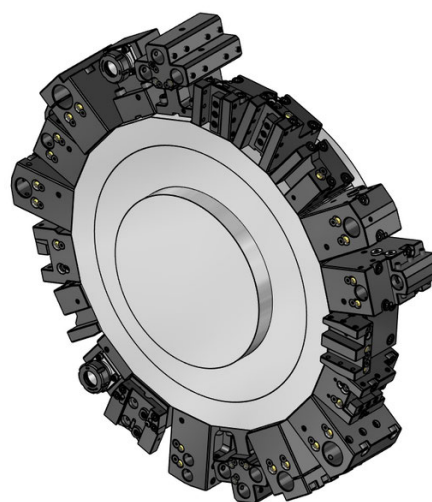
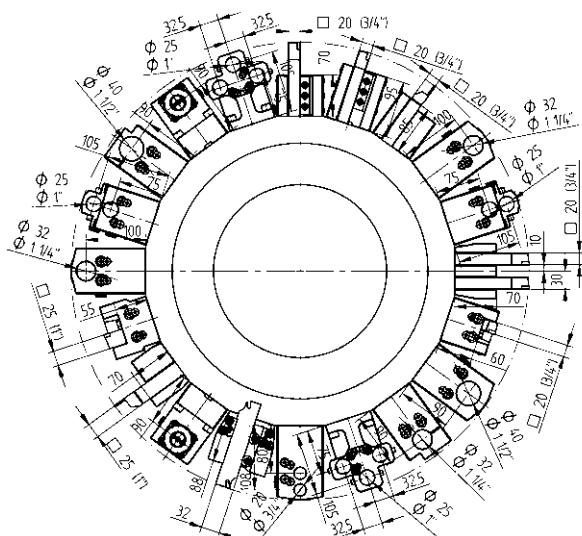

Static Toolholders - Enhanced Program

Static Toolholders - Enhanced Program



Boring bar holder, double, universal
 Ø 20 48-75406
 Ø 3/4" 48-75416



Boring bar holder, double, both sides
 Ø 20 48-75404
 Ø 3/4" 48-75417



Combination toolholder, both sides, triple, Y axis
 Ø 25 48-85908 IC 80 bar
 Ø 1" 48-85985 IC 80 bar



Collet face drill holder
 ER 25 48-107230 IC 80 bar
 107525000
 ER 32 48-81031 IC 80 bar
 107532000



Collet face drill holder, both sides
 ER 25 48-107227 IC 80 bar
 107525000
 ER 32 48-80509 IC 80 bar
 107532000



VDI adapter, left
 VDI 30 48-77732



VDI adapter, right
 VDI 30 48-78687



Boring bar holder, blank
 48-80506

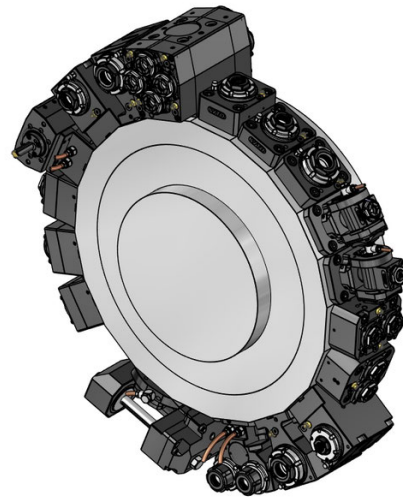
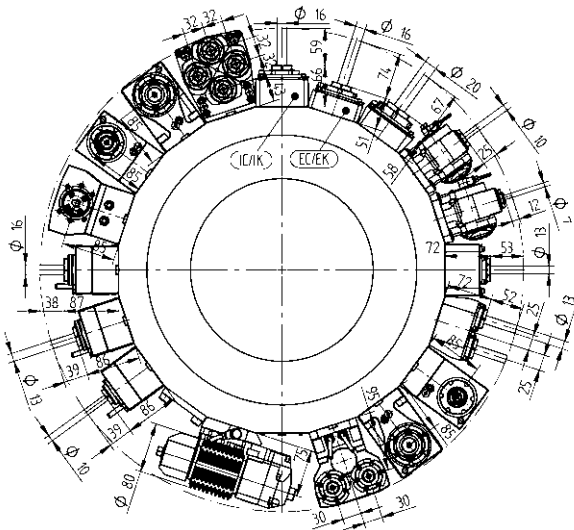

Driven Toolholders - QuickFlex®

Driven Toolholders - QuickFlex®



- OD drill/milling unit (12000 RPM)**
- | | | | |
|-----------------|---------------------------|-----|------------|
| ER-25 QF | 420125012-40
T32433 | 1:1 | EC |
| | 0067725000 | | |
| ER-25 QF | 420125013-40 | 1:1 | IC 80 bar |
| | 0067725000 | | |
| ER-32 QF | QF32-DNE-MS40A-050-E-HS-A | 1:1 | EC |
| | 0067732000 | | |
| ER-32 QF | QF32-DNE-MS40A-067-I-HS-A | 1:1 | IC 100 bar |
| | 0067732000 | | |



- Face drill/milling unit (12000 RPM)**
- | | | | |
|-----------------|---------------------------|-----|------------|
| ER-25 QF | 420525013-40
T32434 | 1:1 | EC |
| | 0067725000 | | |
| ER-25 QF | 420525014-40
T32436 | 1:1 | IC 80 bar |
| | 0067725000 | | |
| ER-32 QF | QF32-DNI-MS40A-085-E-HS-A | 1:1 | EC |
| | 0067732000 | | |
| ER-32 QF | QF32-DNI-MS40A-085-I-HS-A | 1:1 | IC 100 bar |
| | 0067732000 | | |



- OD drill/milling unit (12000 RPM) - QF smart (EU, US, CA, JP)**
- | | | | |
|-----------------|------------------------------|-----|------------|
| ER-32 QF | QF32-DNE-MS40A-067-I-HS-SB-A | 1:1 | IC 100 bar |
| | 0067732000 | | |
| | LI-F12-01 | | |



- Face drill/milling unit (12000 RPM) - QF smart (EU, US, CA, JP)**
- | | | | |
|-----------------|------------------------------|-----|------------|
| ER-32 QF | QF32-DNI-MS40A-085-I-HS-SB-A | 1:1 | IC 100 bar |
| | 0067732000 | | |
| | LI-F12-01 | | |



- OD drill/milling unit (6000 RPM, Heavy Duty)**
- | | | | |
|-----------------|--------------------------------|-----|-----------|
| ER-25 QF | 420125010-40
T32274, T32450 | 1:1 | EC |
| | 0067725000 | | |
| ER-25 QF | 420125011-40
T32287 | 1:1 | IC 80 bar |
| | 0067725000 | | |
| ER-32 QF | 420132010-40
T32475, T32484 | 1:1 | EC |
| | 0067732000 | | |
| ER-32 QF | 420132011-40 | 1:1 | IC 80 bar |
| | 0067732000 | | |



- Face drill/milling unit (6000 RPM, Heavy Duty)**
- | | | | |
|-----------------|--------------------------------|-----|-----------|
| ER-25 QF | 420525010-40
T32275, T32297 | 1:1 | EC |
| | 0067725000 | | |
| ER-25 QF | 420525011-40
T32288, T32435 | 1:1 | IC 80 bar |
| | 0067725000 | | |
| ER-32 QF | 420532010-40
T32476, T32485 | 1:1 | EC |
| | 0067732000 | | |

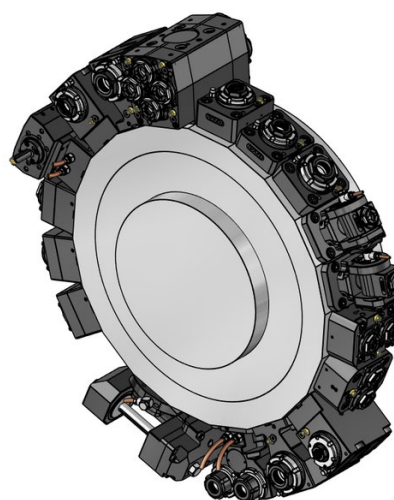
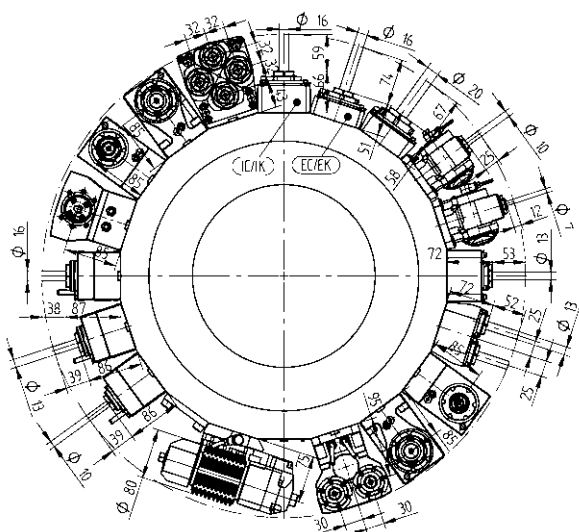

Driven Toolholders - QuickFlex®



Face drill/milling unit, both sides (12000 RPM)

ER-25 QF 420525049-40 1:1 EC
 0067725000

ER-32 QF 420532148-40 1:1 EC
 0067732000



Face drill/milling unit, both sides (6000 RPM, Heavy Duty)

ER-25 QF 420525012-40 1:1 EC
 T32276, T32437
 0067725000

ER-32 QF 420532012-40 1:1 EC
 0067732000

Driven Toolholders - Enhanced Program

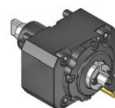

OD milling unit with combination mill arbor DIN 6358

Ø 16 410216010-40 1:1 EC
 00675000854

Ø 22 410222016-40 1:1 EC
 T32280, T32486
 00675000483

Ø 3/4" 410219003-40 1:1 EC
 00675000483



OD drill/milling unit, offset

ER 25 410116050-40 1:1 EC
 T32488
 00675000932

ER 25 410116057-40 1:1 IC 80 bar
 00675000932

ER 20 410113060-40 1:2 EC
 00675000939

ER 20 410113068-40 1:2 IC 80 bar
 00675000939

ER 16 410410003-40 1:3 EC
 00675000937

ER 16 410410004-40 1:3 IC 80 bar
 00675000937

ER 25 410116051-40 2:1 EC
 00675000932

ER 25 410116058-40 2:1 IC 80 bar
 00675000932

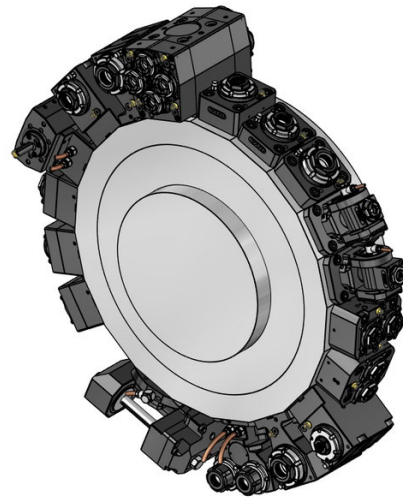
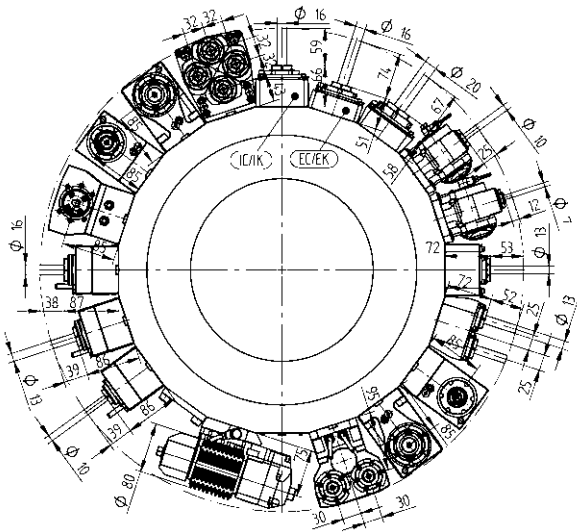

Driven Toolholders - Enhanced Program

Driven Toolholders - Enhanced Program



- OD drill/milling unit, offset (12000 RPM)**
- ER 25** 410116060-40 1:1 EC
00675000932
 - ER 25** 410116059-40 1:1 IC 80 bar
00675000932



- Face back set drill/milling unit**
- ER 25** 410516153-40 1:1 EC
00675000801
 - ER 25** 410516154-40 1:1 IC 80 bar
00675000801



- Face drill/milling unit**
- ER-20 QF** 420520010-40 1:2 EC
0067720001
 - ER-20 QF** 420520011-40 1:2 IC 80 bar
0067720001
 - ER 16** 410810012-40 1:3 EC
0067825001
 - ER 16** 410810013-40 1:3 IC 80 bar
0067825001
 - ER-32 QF** 420532013-40 2:1 EC
0067732000
 - ER-32 QF** QF32-DNI-MS40A-085-I-T-A 2:1 IC 100 bar
0067732000



- Adjustable angle drill/milling unit**
- ER 16** 411010008-40 1:1 EC
00675000913
 - ER 16** 411010009-40 1:1 IC 80 bar
00675000913
 - ER 11** 411007001-40 1:2 EC
00675000914
 - ER 11** 411007002-40 1:2 IC 80 bar
00675000914



- Face milling unit with combination mill arbor DIN 6358**
- Ø 16** 410616013-40 1:1 EC
00675000854
 - Ø 22** 410622030-40 1:1 EC
00675000483
 - Ø 3/4"** 410619003-40 1:1 EC
00675000483

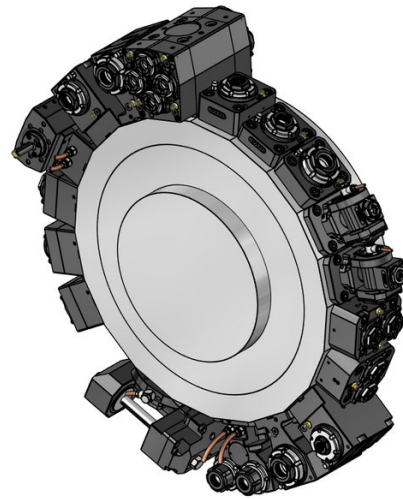
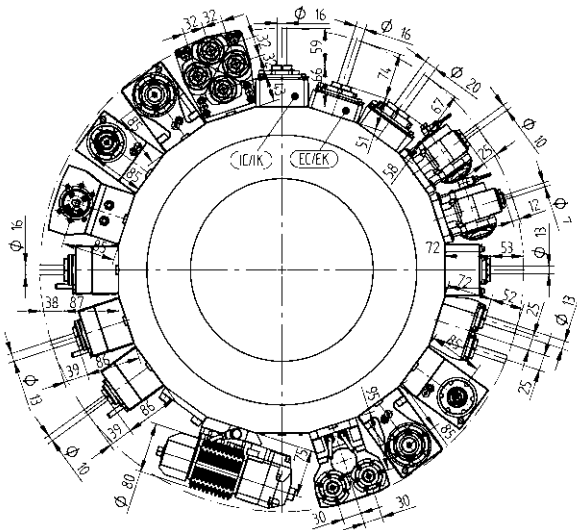

Driven Toolholders - Enhanced Program

Driven Toolholders - Enhanced Program



- Gear hobbing unit**
- | | | | |
|------------------|--------------------|-----|----|
| Type 16-1 | 411500017-40 | 1:1 | EC |
| Type 16-1 | 411500018-40 | 2:1 | EC |
| | 00675000954 | | |
| | 160016161 Ø 16 | | |
| | 160022161 Ø 22 | | |
| | 160027161 Ø 27 | | |
| | 160015161 Ø 5/8" | | |
| | 160019161 Ø 3/4" | | |
| | 160025161 Ø 1" | | |
| | 160031161 Ø 1 1/4" | | |
| | 110587 | | |



- OD drill/milling unit, both sides**
- | | | | |
|--------------|--------------|-----|-----------|
| ER 20 | 413002015-40 | 1:1 | EC |
| | 00675000947 | | |
| ER 20 | 413002018-40 | 1:1 | IC 80 bar |
| | 00675000947 | | |



- OD drill/milling unit, double, Y axis**
- | | | | |
|--------------|--------------|-----|-----------|
| ER 20 | 413002014-40 | 1:1 | EC |
| | 00675000947 | | |
| ER 20 | 413002017-40 | 1:1 | IC 80 bar |
| | 00675000947 | | |

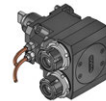

- 2-spindle - Face drill/milling unit, Y axis**
- | | | | |
|--------------|--------------|-----|-----------|
| ER 25 | 413502008-40 | 1:1 | EC |
| | 00675000915 | | |
| ER 25 | 413502009-40 | 1:1 | IC 80 bar |
| | 00675000915 | | |



- 2-spindle - Face drill/milling unit, both sides, Y axis**
- | | | | |
|--------------|--------------|-----|----|
| ER 25 | 413502007-40 | 1:1 | EC |
| | 00675000915 | | |



- 4-spindle - Face drill/milling unit**
- | | | | |
|--------------|--------------|-----|----|
| ER 20 | 413504001-40 | 1:1 | EC |
| | 00675000947 | | |



- 4-spindle - Face drill/milling unit, both sides**
- | | | | |
|--------------|--------------|-----|----|
| ER 20 | 413504000-40 | 1:1 | EC |
| | 00675000947 | | |



- Broaching unit for ID and OD**
- | | | | |
|----------------|--------------|-----|----|
| Type 32 | 414532000-40 | 1:1 | EC |
|----------------|--------------|-----|----|



- Broaching unit for ID and OD**
- | | | | |
|----------------|--------------|-----|----|
| Type 52 | 414552002-40 | 1:1 | EC |
|----------------|--------------|-----|----|

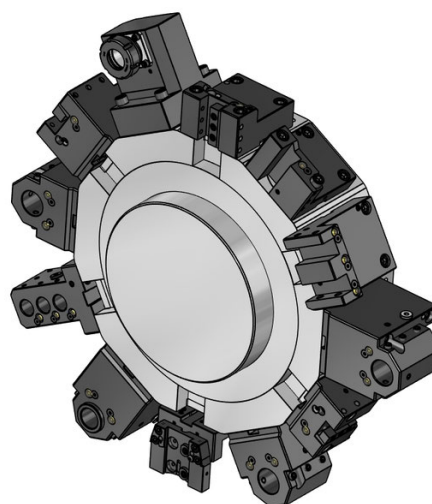
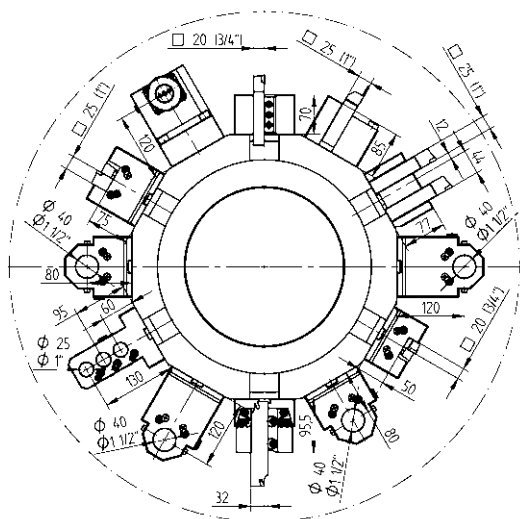

Static Toolholders - Standard Program

Static Toolholders - Standard Program



- OD cutting holder**
- 20 48-T00187
T00187
 - 25 48-T00186
T00186
 - 3/4" 48-T00203
T00203
 - 1" 48-T00202
T00202



- OD cutting holder, HP-IC**
- 25 48-T00186-HP IC 80 bar
T00186
 - 1" 48-T00202-HP IC 80 bar
T00202



- Face cutting holder**
- 20 48-T03006
T03006
 - 25 48-T03005
T03005
 - 3/4" 48-T03014
T03014
 - 1" 48-T03013
T03013



- Face cutting holder, HP-IC**
- 25 48-T03005-HP IC 80 bar
T03005
 - 1" 48-T03013-HP IC 80 bar
T03013



- Cut-off holder, right hand**
- 25 48-T00197
T00197
 - 1" 48-T00198
T00198



- Boring bar holder, LF=80**
- Ø 40 48-T10097
T10097
 - Ø 50 48-T10098
T10098
 - Ø 1 1/2" 48-T10101
T10101
 - Ø 2" 48-T10102
T10102
 - Ø 2 1/2" 48-70080



- Boring bar holder, LF=120**
- Ø 40 48-T10113
T10113
 - Ø 50 48-T10114
T10114
 - Ø 1 1/2" 48-T10134
T10134
 - Ø 2" 48-T10135
T10135

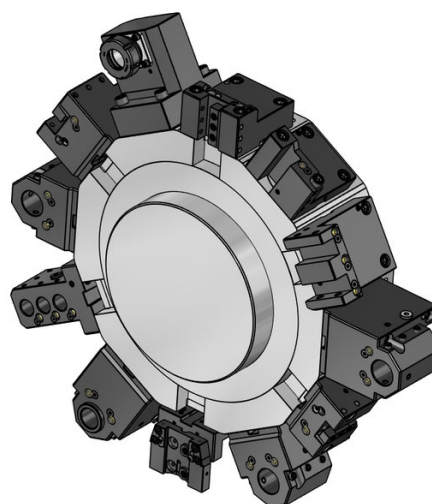
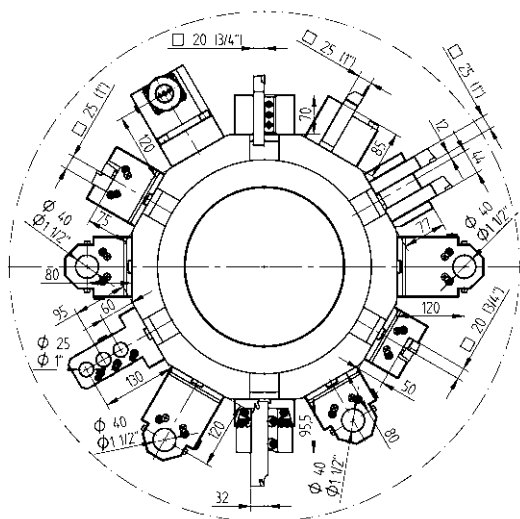

Static Toolholders - Standard Program



Combination toolholder, LF=80

Ø 40	48-T13128 T13128	IC 80 bar
Ø 50	48-T13139 T13139	IC 80 bar
Ø 1 1/2"	48-T13130 T13130	IC 80 bar
Ø 2"	48-T13140 T13140	IC 80 bar



Combination toolholder, LF=120

Ø 40	48-T13131 T13131	IC 80 bar
Ø 50	48-77902	IC 80 bar
Ø 1 1/2"	48-T13137 T13137	IC 80 bar
Ø 2"	48-77901	IC 80 bar

Static Toolholders - Enhanced Program



OD cutting holder, right hand, long, HP-IC

25	48-T00385-HP T00385	IC 80 bar
1"	48-T00386-HP T00386	IC 80 bar



OD cutting holder, left hand, long, HP-IC

25	48-T00387-HP T00387	IC 80 bar
1"	48-T00388-HP T00388	IC 80 bar

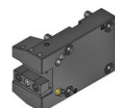

OD cutting holder, short

25	48-79591
1"	48-79593



OD cutting holder, extended

25	48-T00236 T00236
1"	48-T00245 T00245



OD cutting holder, double, Y axis

25(1")	48-71865 T00206, T00210
---------------	----------------------------

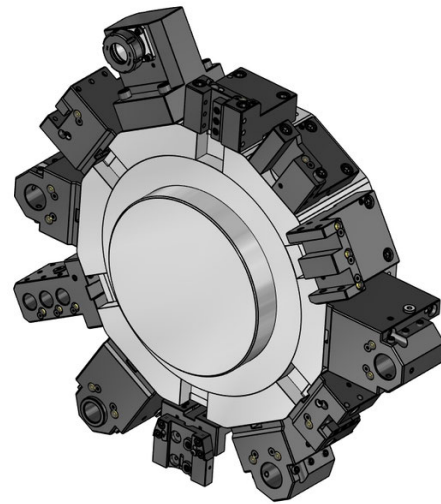
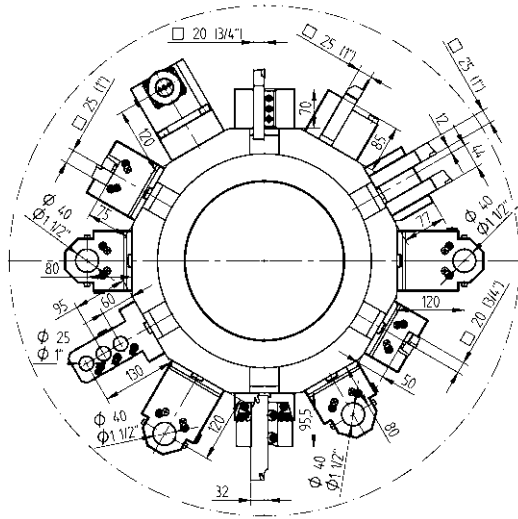

Static Toolholders - Enhanced Program

Static Toolholders - Enhanced Program

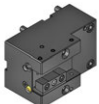

- Face cutting holder, extended**
- 25 48-T03019
T03019
 - 32 48-113046
 - 1" 48-T03020
T03020
 - 1 1/4" 48-112853



- Cut-off holder, adjustable**
- SH 32 48-98901



- Cut-off holder, adjustable, HP-IC**
- SH 32 48-102262R IC 80 bar
 - SH 32 48-102262L IC 80 bar



- Cut-off holder, adjustable, extended**
- SH 32 48-77478



- Boring bar holder, extended**
- Ø 40 48-T13163
T13163
 - Ø 50 48-T13161
T13161
 - Ø 1 1/2" 48-T13164
T13164
 - Ø 2" 48-T13162
T13162



- Boring bar holder, with slot**
- Ø 40 48-T10136
T10136
 - Ø 50 48-T10137
T10137
 - Ø 60 48-70811
 - Ø 1 1/2" 48-T10143
T10143
 - Ø 2" 48-T10142
T10142



- Boring bar holder, triple, universal**
- Ø 25 48-T10104
T10104
 - Ø 1" 48-T10107
T10107

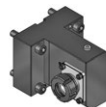

- Collet face drill holder**
- ER 32 48-94564 IC 80 bar
107532000
 - ER 40 48-94566 IC 80 bar
107540000



- VDI adapter, left**
- VDI 30 48-77127
 - VDI 40 48-72984

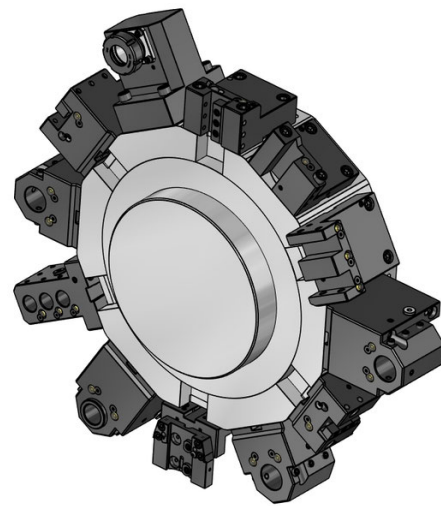
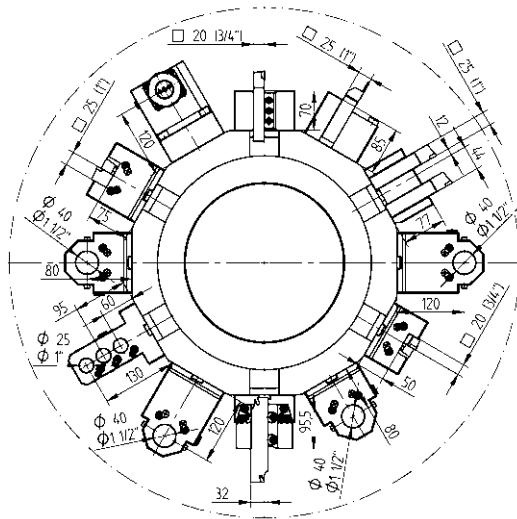

Static Toolholders - Enhanced Program



VDI adapter, right

VDI 30 48-74796
VDI 40 48-77955



Boring bar holder, blank

48-81080

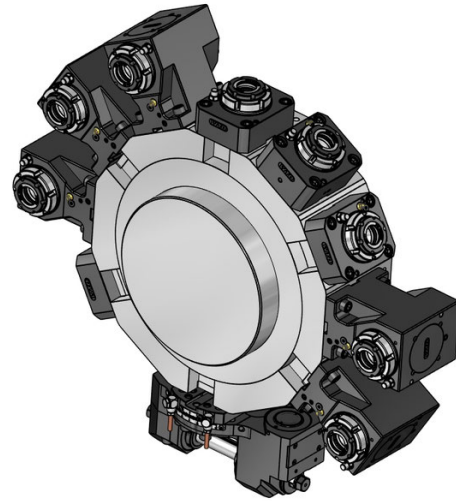
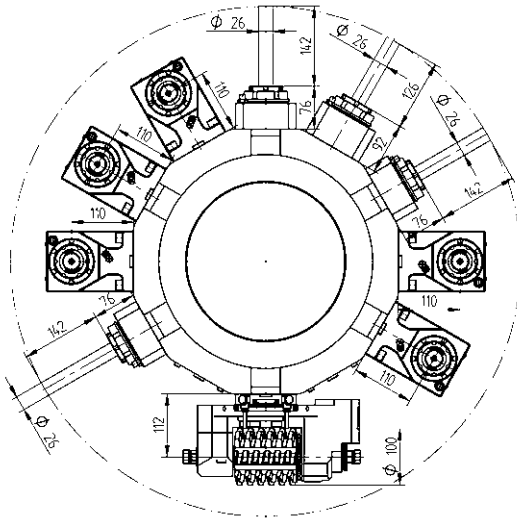

Driven Toolholders - QuickFlex®

Driven Toolholders - QuickFlex®



OD drill/milling unit (12000 RPM)

- ER-32 QF** QF32-DNE-MS60A-072-E-HS-A 1:1 EC
0067732000
- ER-32 QF** QF32-DNE-MS60A-072-I-HS-A 1:1 IC 100 bar
0067732000



OD drill/milling unit (12000 RPM) - QF smart (EU, US, CA, JP)

- ER-32 QF** QF32-DNE-MS60A-072-I-HS-SB-A 1:1 IC 100 bar
0067732000
- LI-F12-01



OD drill/milling unit (6000 RPM, Heavy Duty)

- ER-32 QF** 420132011-60 T32232, T32478 1:1 IC 80 bar
0067732000
- ER-40 QF** 420140010-60 T32213 1:1 EC
0067740000
- ER-40 QF** 420140011-60 T32234 1:1 IC 80 bar
0067740000



OD drill/milling unit (only for NLX 4000 High Torque version)

- ER-40 QF** 420140014-60 T32544 1:1 EC
0067740000
- ER-40 QF** 420140015-60 1:1 IC 80 bar
0067740000



Face drill/milling unit (12000 RPM)

- ER-32 QF** QF32-DNI-MS60A-090-E-HS-A 1:1 EC
0067732000
- ER-32 QF** QF32-DNI-MS60A-090-I-HS-A 1:1 IC 100 bar
0067732000



Face drill/milling unit (12000 RPM) - QF smart (EU, US, CA, JP)

- ER-32 QF** QF32-DNI-MS60A-090-I-HS-SB-A 1:1 IC 100 bar
0067732000
- LI-F12-01



Face drill/milling unit (6000 RPM, Heavy Duty)

- ER-40 QF** 420540012-60 T32214 1:1 EC
0067740000
- ER-40 QF** 420540013-60 T32235 1:1 IC 80 bar
0067740000



Face drill/milling unit (only for NLX 4000 High Torque version)

- ER-40 QF** 420540017-60 T32546 1:1 EC
0067740000
- ER-40 QF** 420540018-60 1:1 IC 80 bar
0067740000

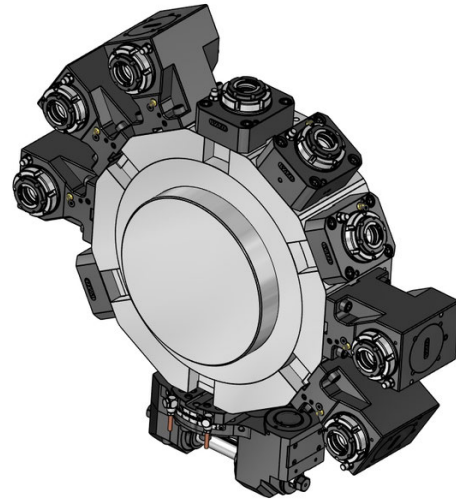
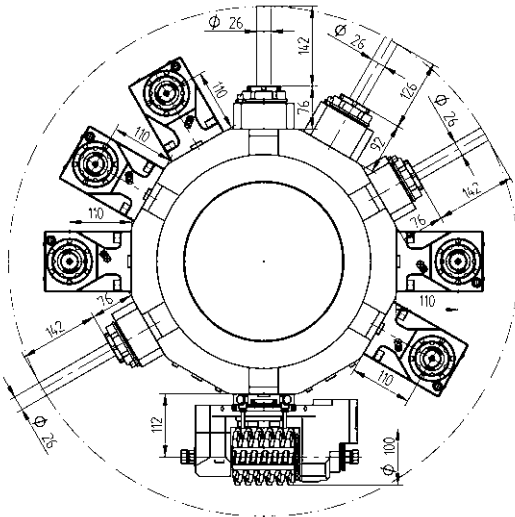

Driven Toolholders - Enhanced Program



**OD milling unit with combination mill arbor
DIN 6358**

Ø 16	410216000-60 00675000854	1:1	EC
Ø 22	410222007-60 T32268 00675000483	1:1	EC
Ø 27	410227008-60 00675000245	1:1	EC
Ø 3/4"	410219000-60 00675000483	1:1	EC
Ø 1"	410225000-60 T32217 00675000483	1:1	EC



OD drill/milling unit, offset

ER-32 QF	420132019-60 0067732000	1:1	EC
ER-32 QF	420132020-60 0067732000	1:1	IC 80 bar
ER-25 QF	420125010-60 0067725001	1:2	EC
ER-25 QF	420125011-60 0067725001	1:2	IC 80 bar
ER-32 QF	420132021-60 0067732000	2:1	EC
ER-32 QF	420132022-60 0067732000	2:1	IC 80 bar



Face drill/milling unit

ER-25 QF	QF25-DNI-MS60A-090-E-S-A 0067725001	1:2	EC
ER-25 QF	QF25-DNI-MS60A-090-I-S-A 0067725001	1:2	IC 100 bar
ER-40 QF	420540014-60 0067740000	2:1	EC
ER-40 QF	420540015-60 0067740000	2:1	IC 80 bar

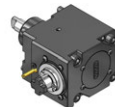

**Face milling unit with combination mill arbor
DIN 6358**

Ø 22	M022-DNI-MS60A-090-E-T-A 00675000483	2:1	EC
Ø 27	M027-DNI-MS60A-090-E-T-A 00675000245	2:1	EC
Ø 1"	M100-DNI-MS60A-090-E-T-A 00675000483	2:1	EC



Adjustable angle drill/milling unit

ER 20	411013009-60 T32474 00675000928	1:1	EC
ER 20	411013010-60 00675000928	1:1	IC 80 bar
ER 16	411010001-60 00675000936	1:2	EC
ER 16	411010002-60 00675000936	1:2	IC 80 bar

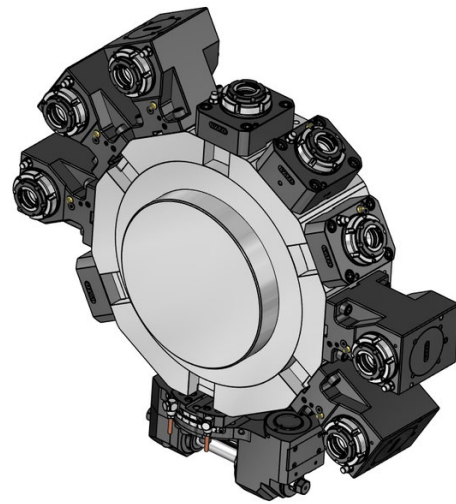
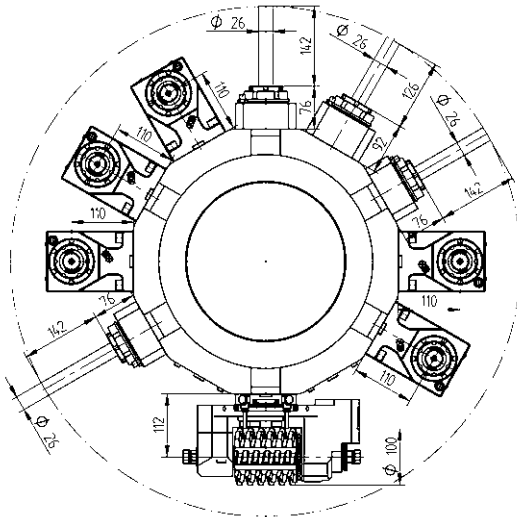

Driven Toolholders - Enhanced Program

Driven Toolholders - Enhanced Program



Slitting saw unit

Type 19-2	411500006-60	3:1	EC
	00675000855		
	160022192 Ø 22		
	160027192 Ø 27		
	160032192 Ø 32		
	160040192 Ø 40		
	160023192 Ø 7/8"		
	160025192 Ø 1"		
	160031192 Ø 1 1/4"		
	160038192 Ø 1 1/2"		



Gear hobbing unit

Type 16-1	411500007-60	1:1	EC
Type 16-1	411500008-60	2:1	EC
	00675000926		
	160016161 Ø 16		
	160022161 Ø 22		
	160027161 Ø 27		
	160015161 Ø 5/8"		
	160019161 Ø 3/4"		
	160025161 Ø 1"		
	160031161 Ø 1 1/4"		
	110587		



Gear hobbing unit (only for NLX 4000 High Torque version)

Type C5-1	410900003-60	2:1	EC
	00675001008		
	160022C51 Ø 22		
	160027C51 Ø 27		
	160032C51 Ø 32		
	160019C51 Ø 3/4"		
	160025C51 Ø 1"		
	160031C51 Ø 1 1/4"		
	110587		



OD drill/milling unit, double, Y axis

ER 25	413002000-60	1:1	EC
	T32267		
	00675000907		
ER 25	413002012-60	1:1	IC 80 bar
	00675000907		

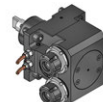

2-spindle - Face drill/milling unit, Y axis

ER 25	413502000-60	1:1	EC
	T32264		
	00675000915		
ER 25	413502002-60	1:1	IC 80 bar
	00675000915		

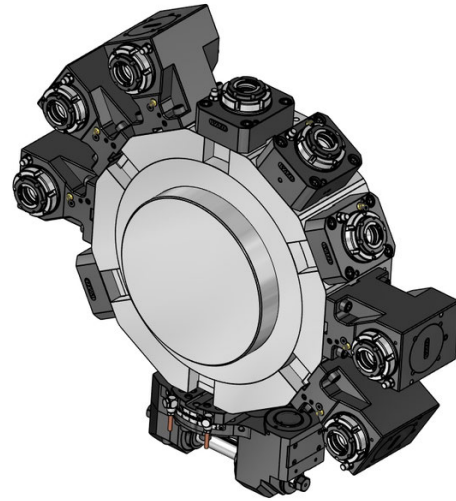
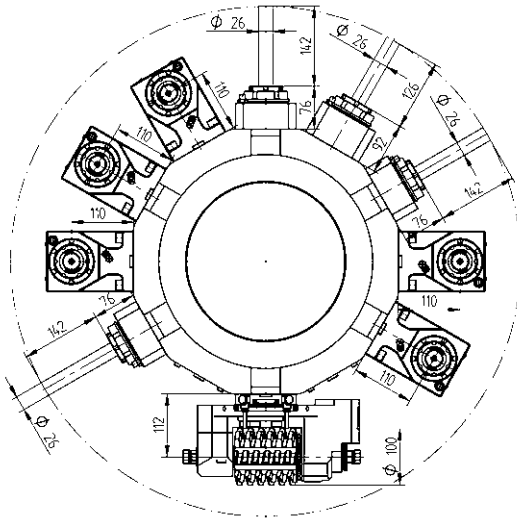

Driven Toolholders - Enhanced Program

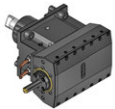

Broaching unit for ID and OD

Type 32	414532000-60	1:1	EC
Type 52	414552000-60	1:1	EC

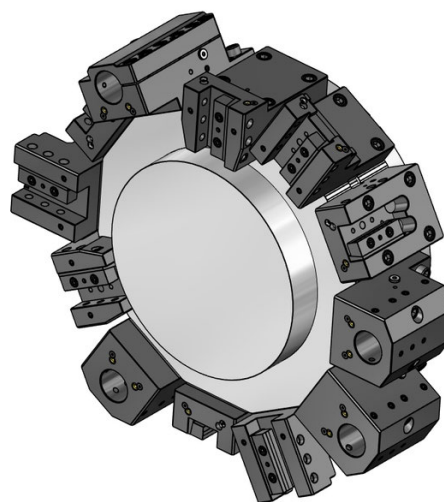
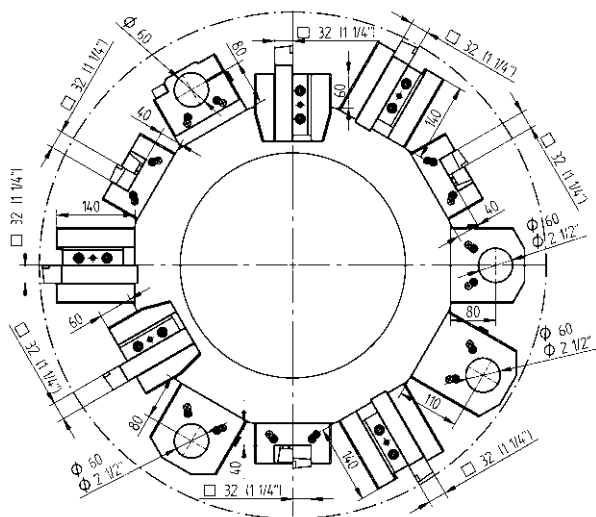

Static Toolholders - Standard Program

Static Toolholders - Standard Program



- OD cutting holder**
- 32** 48-T00432
T00432
 - 1 1/4"** 48-T00433
T00433



- Combination toolholder, LF=110**
- Ø 60** 48-T12149 IC 80 bar
T12149
 - Ø 2 1/2"** 48-T12150 IC 80 bar
T12150



- OD cutting holder, long (only for turret 1)**
- 32** 48-T00434
T00434
 - 1 1/4"** 48-T00435
T00435



- Face cutting holder**
- 32** 48-T03042
T03042
 - 1 1/4"** 48-T03043
T03043



- Combination toolholder, LF=80**
- Ø 60** 48-T10203 IC 80 bar
T10203
 - Ø 2 1/2"** 48-T10204 IC 80 bar
T10204
 - Ø 80** 48-115987 IC 80 bar
 - Ø 3"** 48-115988 IC 80 bar

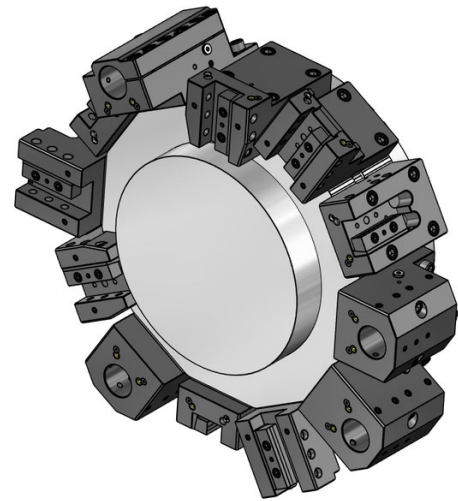
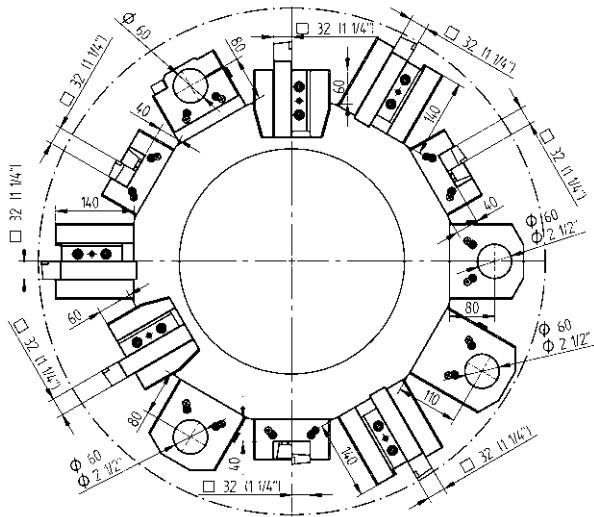

Static Toolholders - Enhanced Program



Ø 60

Boring bar holder, with slot

48-108639



Ø 80

Boring bar holder, with slot (only for turret 1)

48-118772

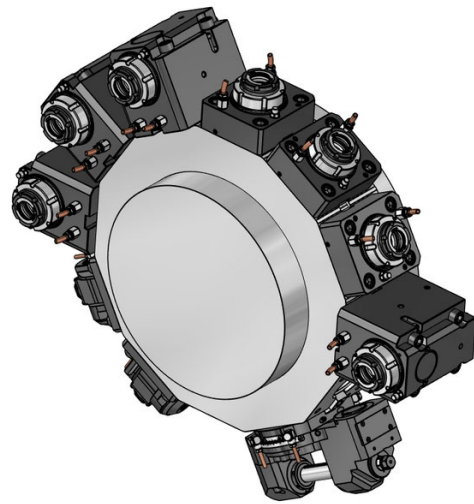
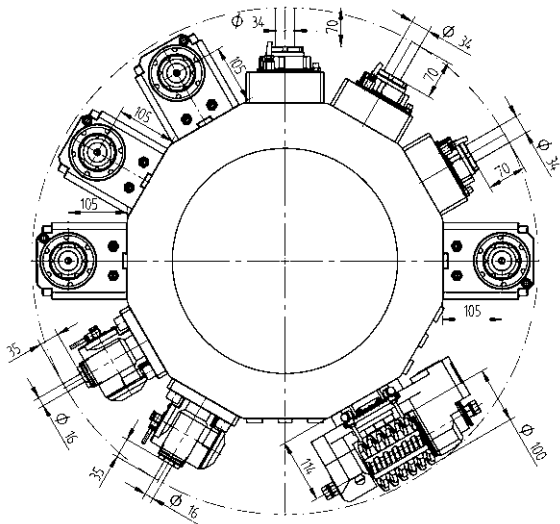

Driven Toolholders - QuickFlex®



OD drill/milling unit (8000 RPM)

- ER-50 QF** 420150012-75 1:1 EC
T32659
0067750000
- ER-50 QF** 420150013-75 1:1 IC 80 bar
0067750000



Face drill/milling unit (8000 RPM)

- ER-50 QF** 420550012-75 1:1 EC
T32660
0067750000
- ER-50 QF** 420550013-75 1:1 IC 80 bar
0067750000

Driven Toolholders - Enhanced Program



Adjustable angle drill/milling unit

- ER 25** 411016002-75 1:1 EC
00675000934
- ER 25** 411016003-75 1:1 IC 80 bar
00675000934
- ER 16** 411010004-75 1:2 EC
00675000936
- ER 16** 411010005-75 1:2 IC 80 bar
00675000936



Gear hobbing unit

- Type C5-1** 410900000-75 2:1 EC
00675001008
- 160022C51 Ø 22
- 160027C51 Ø 27
- 160032C51 Ø 32
- 160019C51 Ø 3/4"
- 160025C51 Ø 1"
- 160031C51 Ø 1 1/4"
- 110587

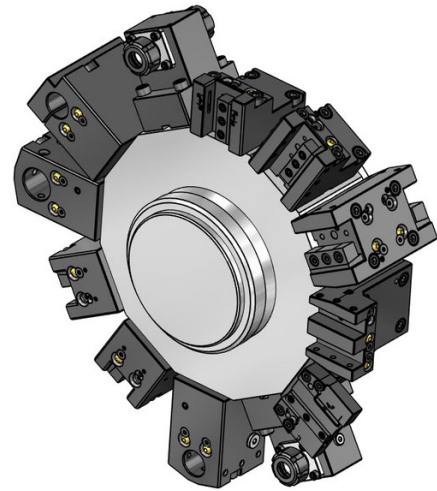
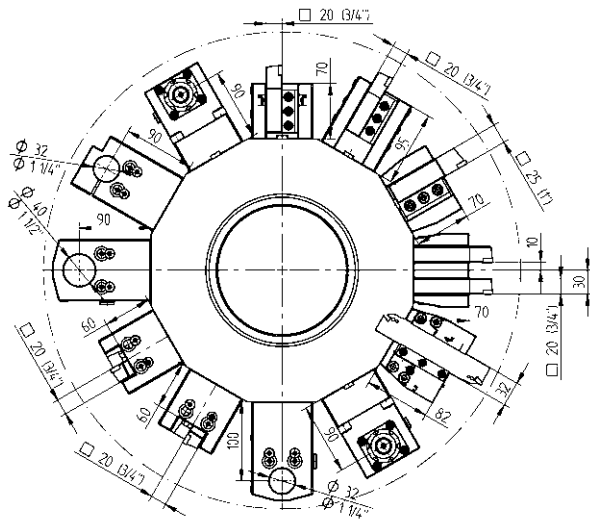

Static Toolholders - Standard Program

Static Toolholders - Standard Program



- OD cutting holder, short**
- 20 48-T00224
T00224
 - 25 48-T00267
T00267
 - 3/4" 48-T00234
T00234
 - 1" 48-T00272
T00272



- OD cutting holder, both sides, short, HP-IC**
- 20 48-T00228-HP IC 80 bar
T00228
 - 25 48-86523-HP IC 80 bar
 - 3/4" 48-T00250-HP IC 80 bar
T00250
 - 1" 48-86524-HP IC 80 bar



- OD cutting holder, short, HP-IC**
- 20 48-T00224-HP IC 80 bar
T00224
 - 25 48-T00267-HP IC 80 bar
T00267
 - 3/4" 48-T00234-HP IC 80 bar
T00234
 - 1" 48-T00272-HP IC 80 bar
T00272



- OD cutting holder, both sides, long**
- 20 48-T00226
T00226
 - 3/4" 48-T00249
T00249



- OD cutting holder, long**
- 20 48-T00225
T00225
 - 3/4" 48-T00235
T00235



- Face cutting holder**
- 25 48-T03024
T03024
 - 3/4" 48-T03018
T03018
 - 1" 48-T03025
T03025



- OD cutting holder, both sides, short**
- 20 48-T00228
T00228
 - 25 48-86523
 - 3/4" 48-T00250
T00250
 - 1" 48-86524



- Face cutting holder, HP-IC**
- 20 48-T03017-HP IC 80 bar
T03017
 - 3/4" 48-T03018-HP IC 80 bar
T03018

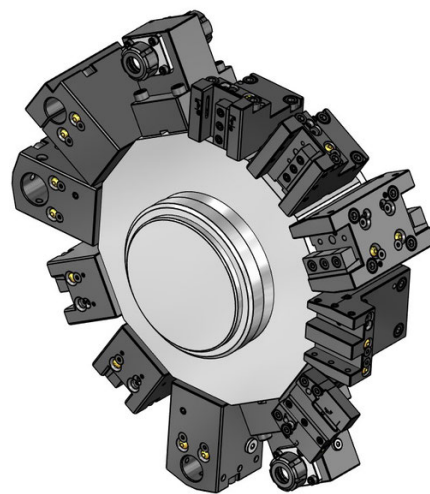
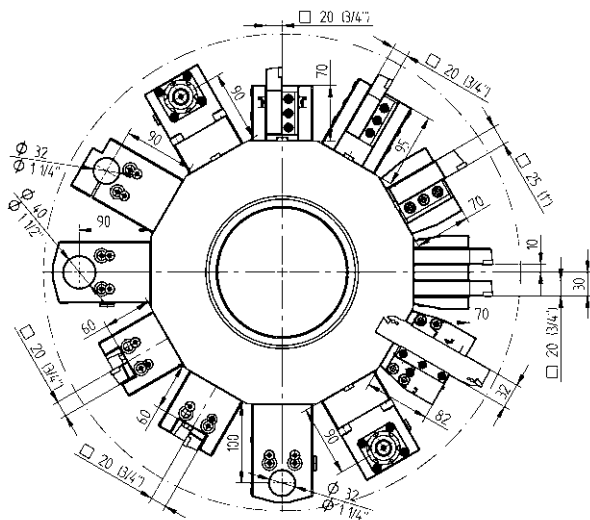

Static Toolholders - Standard Program



- Cut-off holder, right hand**
- 20 48-T00251
T00251
 - 25 48-T00268
T00268, T00356
 - 3/4" 48-T00252
T00252
 - 1" 48-T00359
T00359, T00357



- Boring bar holder**
- Ø 32 48-T10115
T10115
 - Ø 1 1/4" 48-T10119
T10119



- Combination toolholder**
- Ø 32 48-T13132 IC 80 bar
T13132
 - Ø 40 48-77999 IC 80 bar
 - Ø 1 1/4" 48-T13135 IC 80 bar
T13135
 - Ø 1 1/2" 48-80016 IC 80 bar

Static Toolholders - Enhanced Program



- OD cutting holder, double, Y axis**
- 20 (3/4") 48-77726



- OD cutting holder, both sides, double, Y axis**
- 20 (3/4") 48-77727



- Face cutting holder, both sides**
- 20 48-79608
 - 3/4" 48-79609



- Cut-off holder, adjustable**
- SH 32 48-98891



- Cut-off holder, adjustable, HP-IC**
- SH 32 48-102261R IC 80 bar
 - SH 32 48-102261L IC 80 bar



- Boring bar holder, with slot**
- Ø 32 48-82057
 - Ø 40 48-82058
 - Ø 1 1/4" 48-82059
 - Ø 1 1/2" 48-82060

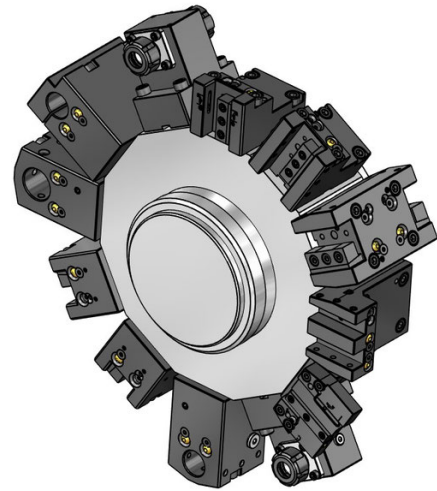
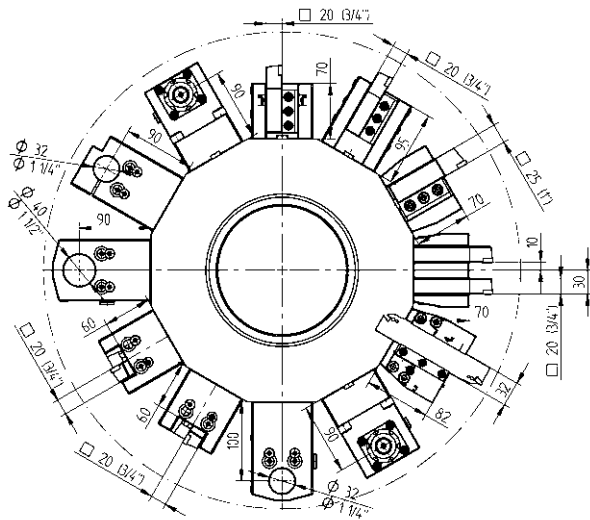

Static Toolholders - Enhanced Program



- Collet face drill holder**
- ER 25 48-107230 IC 80 bar
 107525000
 - ER 32 48-81031 IC 80 bar
 107532000



- Collet face drill holder, both sides**
- ER 25 48-107227 IC 80 bar
 107525000
 - ER 32 48-80509 IC 80 bar
 107532000



- Boring bar holder, blank**
- 48-80506

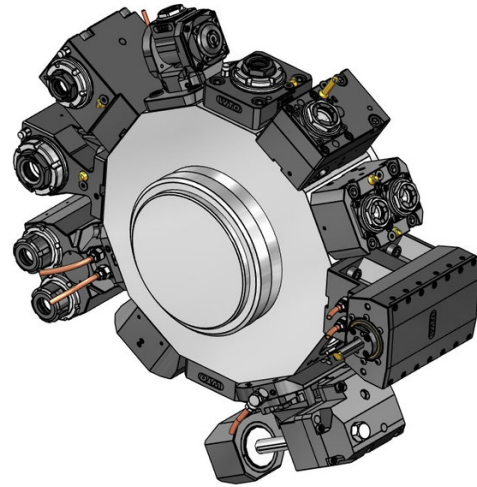
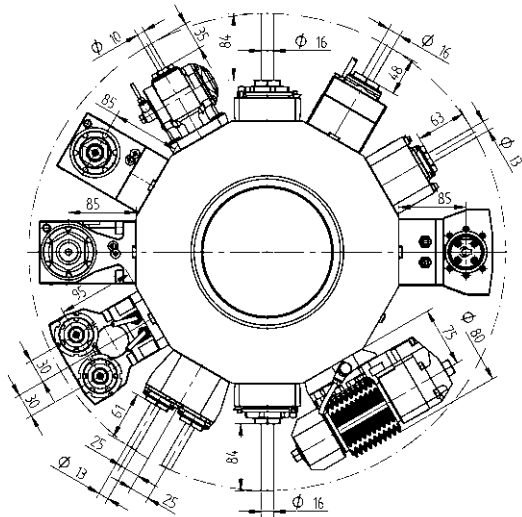

Driven Toolholders - QuickFlex®

Driven Toolholders - QuickFlex®



- OD drill/milling unit (12000 RPM)**
- ER-25 QF** 420125012-40 1:1 EC
T32433
0067725000
 - ER-25 QF** 420125013-40 1:1 IC 80 bar
0067725000
 - ER-32 QF** QF32-DNE-MS40A-050-E-HS-A 1:1 EC
0067732000
 - ER-32 QF** QF32-DNE-MS40A-067-I-HS-A 1:1 IC 100 bar
0067732000



- Face drill/milling unit (12000 RPM)**
- ER-25 QF** 420525013-40 1:1 EC
T32434
0067725000
 - ER-25 QF** 420525014-40 1:1 IC 80 bar
T32436
0067725000
 - ER-32 QF** QF32-DNI-MS40A-085-E-HS-A 1:1 EC
0067732000
 - ER-32 QF** QF32-DNI-MS40A-085-I-HS-A 1:1 IC 100 bar
0067732000



- OD drill/milling unit (12000 RPM) - QF smart (EU, US, CA, JP)**
- ER-32 QF** QF32-DNE-MS40A-067-I-HS-SB-A 1:1 IC 100 bar
0067732000
LI-F12-01



- Face drill/milling unit (12000 RPM) - QF smart (EU, US, CA, JP)**
- ER-32 QF** QF32-DNI-MS40A-085-I-HS-SB-A 1:1 IC 100 bar
0067732000
LI-F12-01





- OD drill/milling unit (6000 RPM, Heavy Duty)**
- ER-25 QF** 420125010-40 1:1 EC
T32274, T32450
0067725000
 - ER-25 QF** 420125011-40 1:1 IC 80 bar
T32287
0067725000
 - ER-32 QF** 420132010-40 1:1 EC
T32475, T32484
0067732000
 - ER-32 QF** 420132011-40 1:1 IC 80 bar
0067732000



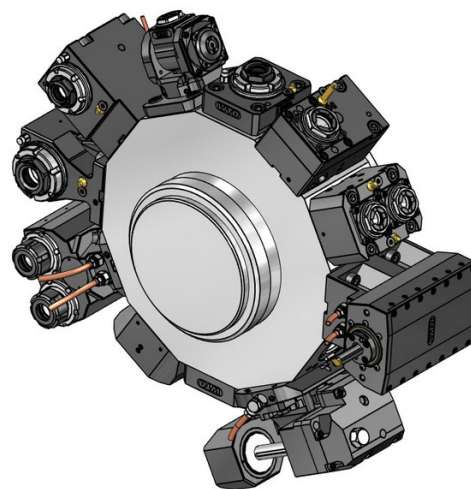
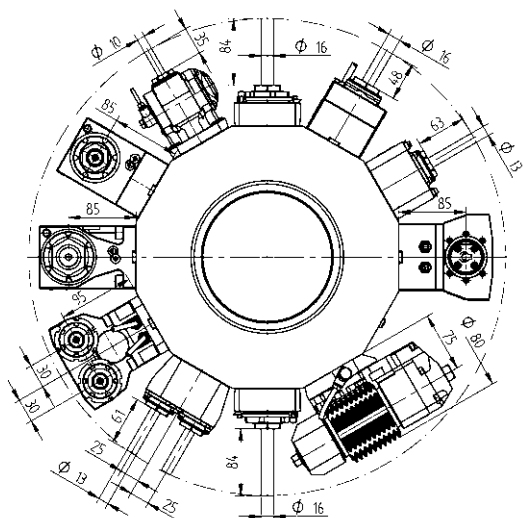

- Face drill/milling unit (6000 RPM, Heavy Duty)**
- ER-25 QF** 420525010-40 1:1 EC
T32275, T32297
0067725000
 - ER-25 QF** 420525011-40 1:1 IC 80 bar
T32288, T32435
0067725000
 - ER-32 QF** 420532010-40 1:1 EC
T32476, T32485
0067732000















Driven Toolholders - QuickFlex®

- 
- Face drill/milling unit, both sides (12000 RPM)**
- | | | | |
|-----------------|--|-----|----|
| ER-25 QF | 420525049-40 | 1:1 | EC |
| |  0067725000 | | |
| ER-32 QF | 420532148-40 | 1:1 | EC |
| |  0067732000 | | |

- 
- Face drill/milling unit, both sides (6000 RPM, Heavy Duty)**
- | | | | |
|-----------------|--|-----|----|
| ER-25 QF | 420525012-40 | 1:1 | EC |
| | T32276, T32437 | | |
| |  0067725000 | | |
| ER-32 QF | 420532012-40 | 1:1 | EC |
| |  0067732000 | | |

Driven Toolholders - Enhanced Program

- 
- OD milling unit with combination mill arbor
DIN 6358**
- | | | | |
|---------------|---|-----|----|
| Ø 16 | 410216010-40 | 1:1 | EC |
| |  00675000854 | | |
| Ø 22 | 410222016-40 | 1:1 | EC |
| | T32280, T32486 | | |
| |  00675000483 | | |
| Ø 3/4" | 410219003-40 | 1:1 | EC |
| |  00675000483 | | |

- 
- OD drill/milling unit, offset**
- | | | | |
|--------------|---|-----|-----------|
| ER 25 | 410116050-40 | 1:1 | EC |
| | T32488 | | |
| |  00675000932 | | |
| ER 25 | 410116057-40 | 1:1 | IC 80 bar |
| |  00675000932 | | |
| ER 20 | 410113060-40 | 1:2 | EC |
| |  00675000939 | | |
| ER 20 | 410113068-40 | 1:2 | IC 80 bar |
| |  00675000939 | | |
| ER 16 | 410410003-40 | 1:3 | EC |
| |  00675000937 | | |
| ER 16 | 410410004-40 | 1:3 | IC 80 bar |
| |  00675000937 | | |
| ER 25 | 410116051-40 | 2:1 | EC |
| |  00675000932 | | |
| ER 25 | 410116058-40 | 2:1 | IC 80 bar |
| |  00675000932 | | |

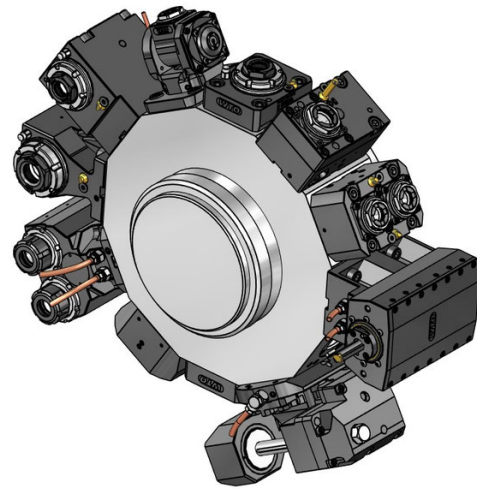
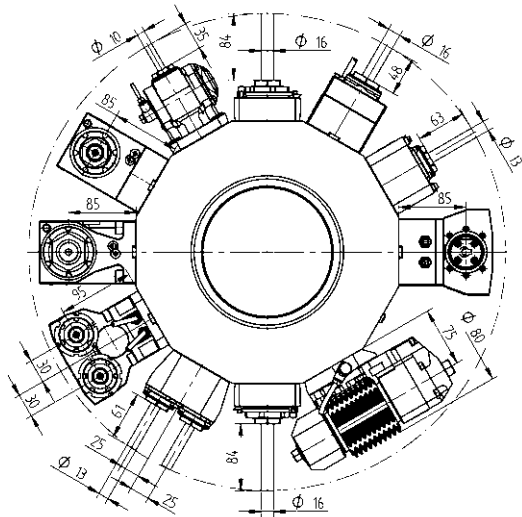

Driven Toolholders - Enhanced Program



OD drill/milling unit, offset (12000 RPM)

- ER 25** 410116060-40 1:1 EC
 00675000932
- ER 25** 410116059-40 1:1 IC 80 bar
 00675000932



Face drill/milling unit

- ER-20 QF** 420520010-40 1:2 EC
 0067720001
- ER-20 QF** 420520011-40 1:2 IC 80 bar
 0067720001
- ER 16** 410810012-40 1:3 EC
 0067825001
- ER 16** 410810013-40 1:3 IC 80 bar
 0067825001
- ER-32 QF** 420532013-40 2:1 EC
 0067732000
- ER-32 QF** QF32-DNI-MS40A-085-I-T-A 2:1 IC 100 bar
 0067732000



**Face milling unit with combination mill arbor
DIN 6358**

- Ø 16** 410616013-40 1:1 EC
 00675000854
- Ø 22** 410622030-40 1:1 EC
 00675000483
- Ø 3/4"** 410619003-40 1:1 EC
 00675000483

Driven Toolholders - Enhanced Program



Face back set drill/milling unit

- ER 25** 410516153-40 1:1 EC
 00675000801
- ER 25** 410516154-40 1:1 IC 80 bar
 00675000801

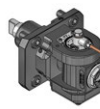

Adjustable angle drill/milling unit

- ER 16** 411010008-40 1:1 EC
 00675000913
- ER 16** 411010009-40 1:1 IC 80 bar
 00675000913
- ER 11** 411007001-40 1:2 EC
 00675000914
- ER 11** 411007002-40 1:2 IC 80 bar
 00675000914

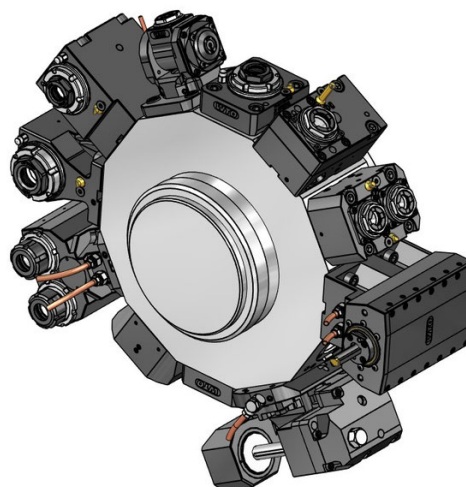
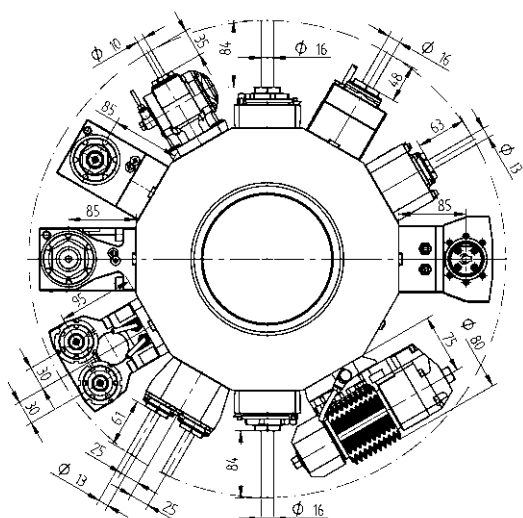

Driven Toolholders - Enhanced Program



Gear hobbing unit			
Type 16-1	411500017-40	1:1	EC
Type 16-1	411500018-40	2:1	EC
	00675000954		
	160016161 Ø 16		
	160022161 Ø 22		
	160027161 Ø 27		
	160015161 Ø 5/8"		
	160019161 Ø 3/4"		
	160025161 Ø 1"		
	160031161 Ø 1 1/4"		
	110587		



OD drill/milling unit, both sides			
ER 20	413002015-40	1:1	EC
	00675000947		
ER 20	413002018-40	1:1	IC 80 bar
	00675000947		



OD drill/milling unit, double, Y axis			
ER 20	413002014-40	1:1	EC
	00675000947		
ER 20	413002017-40	1:1	IC 80 bar
	00675000947		

Driven Toolholders - Enhanced Program

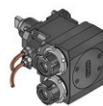

2-spindle - Face drill/milling unit, Y axis			
ER 25	413502008-40	1:1	EC
	00675000915		
ER 25	413502009-40	1:1	IC 80 bar
	00675000915		



2-spindle - Face drill/milling unit, both sides, Y axis			
ER 25	413502007-40	1:1	EC
	00675000915		



Broaching unit for ID and OD			
Type 32	414532000-40	1:1	EC



Broaching unit for ID and OD			
Type 52	414552002-40	1:1	EC

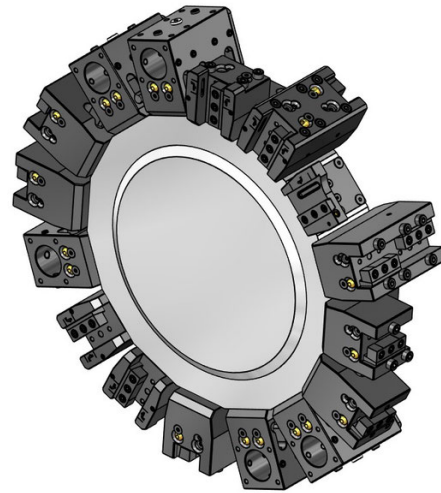
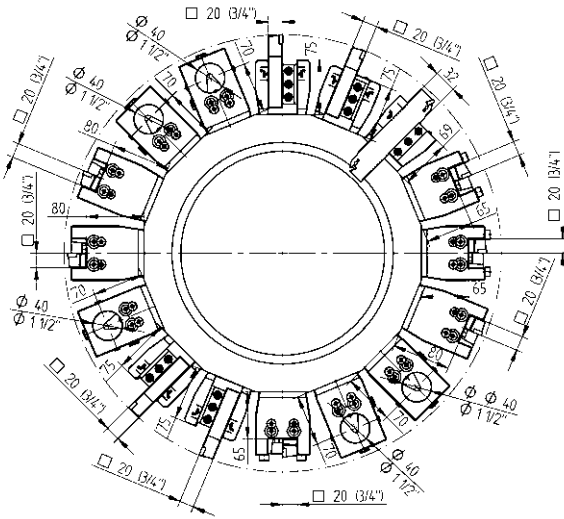

Static Toolholders - Standard Program

Static Toolholders - Enhanced Program



20
3/4"

OD cutting holder, HP-IC

S020-TNE-MS42A-075-I-A IC 80 bar
S075-TNE-MS42A-075-I-A IC 80 bar



20
3/4"

OD cutting holder, both sides, HP-IC

S020-TNE-MS42A-075-I-DT-A IC 80 bar
S075-TNE-MS42A-075-I-DT-A IC 80 bar



20
3/4"

Face cutting holder

S020-TNI-MS42A-087-E-A
S075-TNI-MS42A-087-E-A



20
3/4"

Face cutting holder

S020-TNI-MS42A-100-E-A
S075-TNI-MS42A-100-E-A



20
3/4"

Face cutting holder, both sides

S020-TNI-MS42A-087-E-DT-A
S075-TNI-MS42A-087-E-DT-A

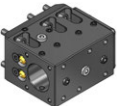

Ø 40

Combination toolholder, universal

D040-TNI-MS42A-070-I-DT-A IC 80 bar
241140020 ER32
241140026 ER40

Ø 1 1/2"

D150-TNI-MS42A-070-I-DT-A IC 80 bar



SH 32

Cut-off holder, adjustable

SH32-TNE-MS42A-077-E-A



SH 32
SH 32

Cut-off holder, adjustable, HP-IC

SH32-TRE-MS42A-077-I-A IC 80 bar
SH32-TLE-MS42A-077-I-A IC 80 bar

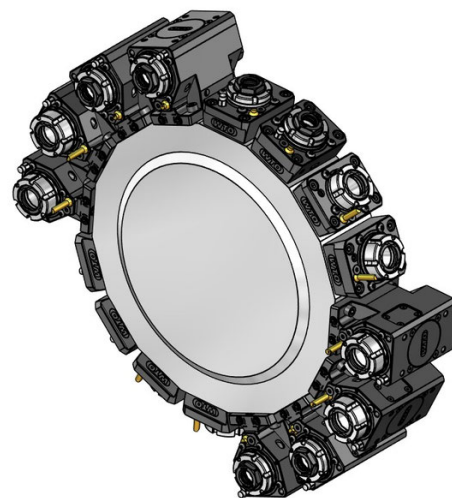
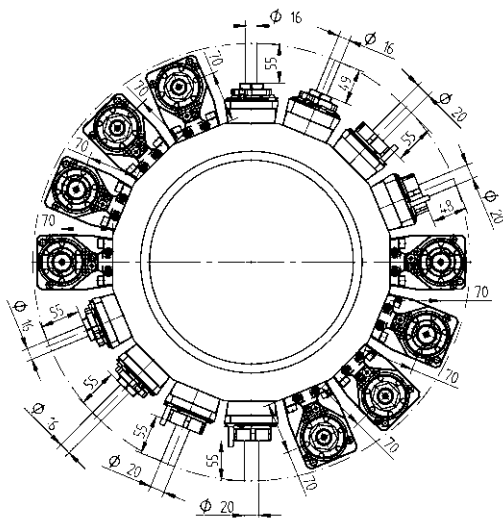

Driven Toolholders - QuickFlex®



OD drill/milling unit (12000 RPM)

ER-25 QF QF25-DNE-MS42A-047-E-A 1:1 EC
 0067725000

ER-25 QF QF25-DNE-MS42A-053-I-A 1:1 IC 100 bar
 0067725000



Face drill/milling unit (12000 RPM)

ER-25 QF QF25-DNI-MS42A-070-E-A 1:1 EC
 0067725000

ER-25 QF QF25-DNI-MS42A-070-I-A 1:1 IC 100 bar
 0067725000

Driven Toolholders - Enhanced Program



OD drill/milling unit (12000 RPM)

ER 32 ER32-DNE-MS42A-055-E-A 1:1 EC
 0067725030

ER 32 ER32-DNE-MS42A-062-I-A 1:1 IC 100 bar
 0067725030

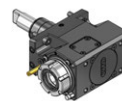

Face drill/milling unit (12000 RPM)

ER 32 ER32-DNI-MS42A-070-E-A 1:1 EC
 0067725030

ER 32 ER32-DNI-MS42A-070-I-A 1:1 IC 100 bar
 0067725030

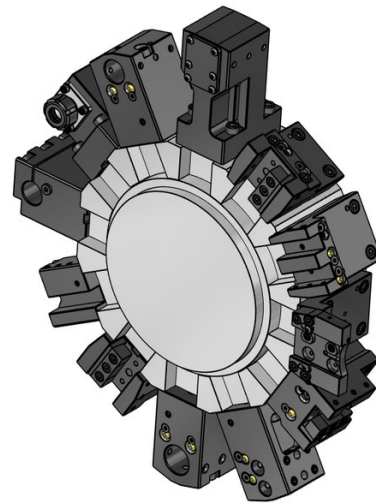
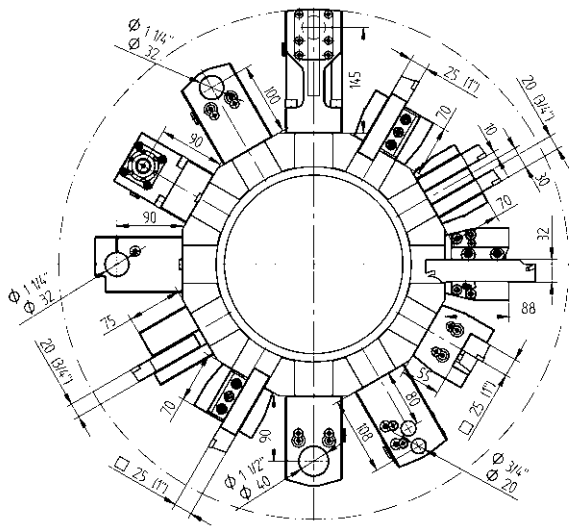

Static Toolholders - Standard Program

Static Toolholders - Standard Program



- OD cutting holder, short**
- 20 48-T00224
T00224
 - 25 48-T00267
T00267
 - 3/4" 48-T00234
T00234
 - 1" 48-T00272
T00272



- OD cutting holder, short, HP-IC**
- 20 48-T00224-HP IC 80 bar
T00224
 - 25 48-T00267-HP IC 80 bar
T00267
 - 3/4" 48-T00234-HP IC 80 bar
T00234
 - 1" 48-T00272-HP IC 80 bar
T00272



- OD cutting holder, long**
- 20 48-T00225
T00225
 - 3/4" 48-T00235
T00235



- OD cutting holder, both sides, short**
- 20 48-T00228
T00228
 - 25 48-86523
 - 3/4" 48-T00250
T00250
 - 1" 48-86524



- OD cutting holder, both sides, short, HP-IC**
- 20 48-T00228-HP IC 80 bar
T00228
 - 25 48-86523-HP IC 80 bar
 - 3/4" 48-T00250-HP IC 80 bar
T00250
 - 1" 48-86524-HP IC 80 bar



- OD cutting holder, both sides, long**
- 20 48-T00226
T00226
 - 3/4" 48-T00249
T00249



- Face cutting holder**
- 25 48-T03024
T03024
 - 3/4" 48-T03018
T03018
 - 1" 48-T03025
T03025



- Face cutting holder, HP-IC**
- 20 48-T03017-HP IC 80 bar
T03017
 - 3/4" 48-T03018-HP IC 80 bar
T03018

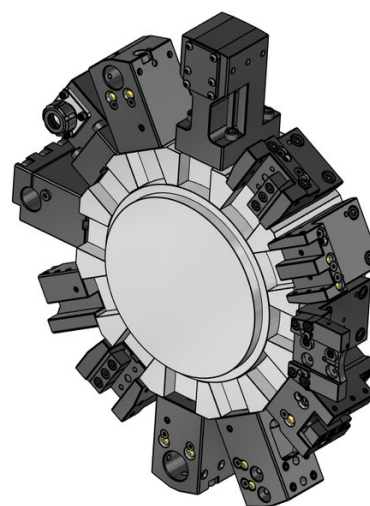
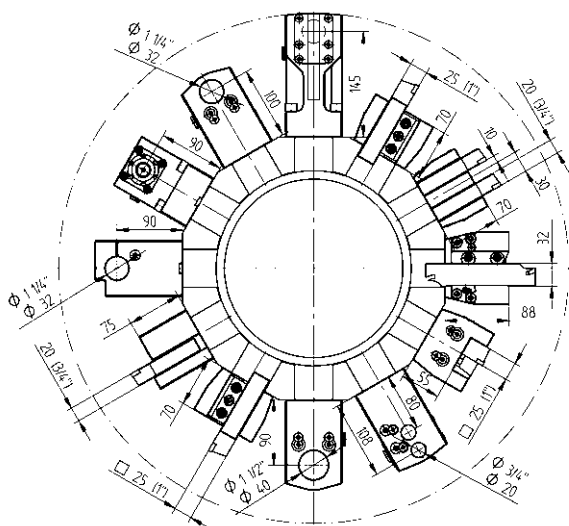

Static Toolholders - Standard Program



- Cut-off holder, right hand**
- 20 48-T00251
T00251
 - 25 48-T00268
T00268, T00356
 - 3/4" 48-T00252
T00252
 - 1" 48-T00359
T00359, T00357



- Boring bar holder**
- Ø 32 48-T10115
T10115
 - Ø 1 1/4" 48-T10119
T10119



- Combination toolholder**
- Ø 32 48-T13132 IC 80 bar
T13132
 - Ø 40 48-77999 IC 80 bar
 - Ø 1 1/4" 48-T13135 IC 80 bar
T13135
 - Ø 1 1/2" 48-80016 IC 80 bar



- Combination toolholder, sub spindle**
- Ø 32 48-T10260 IC 80 bar
T10260
 - Ø 1 1/4" 48-T10261 IC 80 bar
T10261

Static Toolholders - Enhanced Program



- OD cutting holder, double, Y axis**
- 20 (3/4") 48-77726



- OD cutting holder, both sides, short, extended**
- 20 48-79403
 - 3/4" 48-82167



- OD cutting holder, both sides, long, extended**
- 20 48-81414
 - 3/4" 48-82168



- Cut-off holder, adjustable**
- SH 32 48-98891



- Cut-off holder, adjustable, HP-IC**
- SH 32 48-102261R IC 80 bar
 - SH 32 48-102261L IC 80 bar



- Boring bar holder, with slot**
- Ø 32 48-82057
 - Ø 40 48-82058
 - Ø 1 1/4" 48-82059
 - Ø 1 1/2" 48-82060

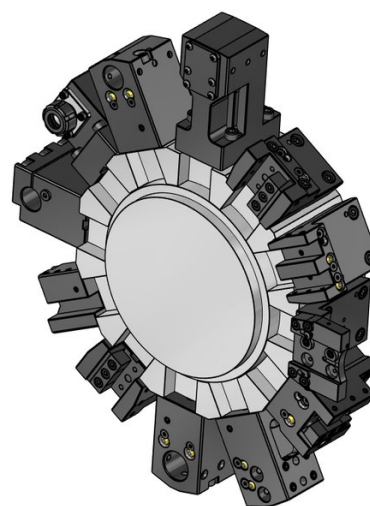
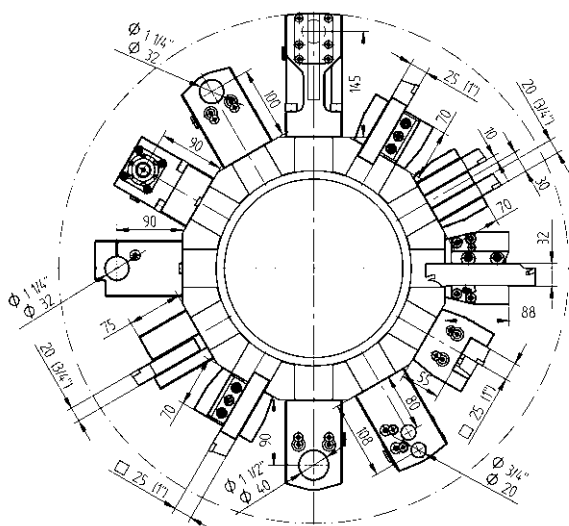

Static Toolholders - Enhanced Program



Boring bar holder, double, universal
 Ø 20 48-75406
 Ø 3/4" 48-75416



Collet face drill holder
 ER 25 48-107230 IC 80 bar
 107525000
 ER 32 48-81031 IC 80 bar
 107532000



VDI adapter, left
 VDI 30 48-77732



VDI adapter, right
 VDI 30 48-78687



Boring bar holder, blank
 48-80506

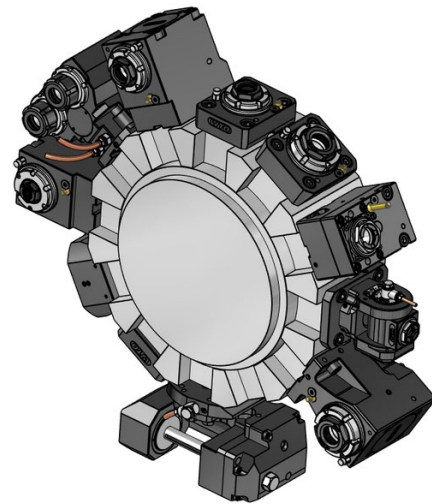
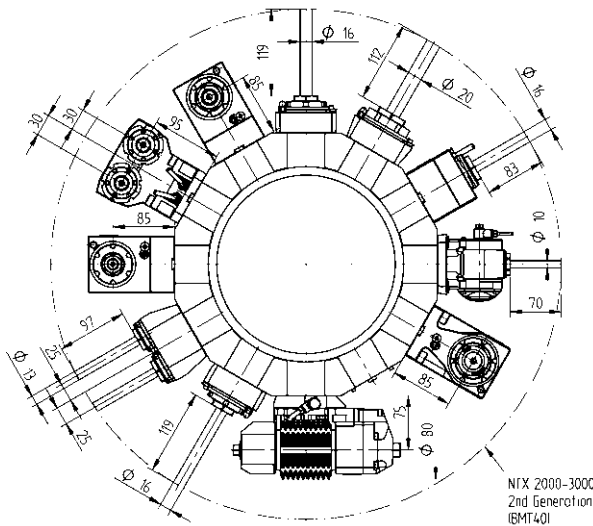

Driven Toolholders - QuickFlex®



- OD drill/milling unit (12000 RPM)**
- | | | | |
|-----------------|---------------------------|-----|------------|
| ER-25 QF | 420125012-40
T32433 | 1:1 | EC |
| | 0067725000 | | |
| ER-25 QF | 420125013-40 | 1:1 | IC 80 bar |
| | 0067725000 | | |
| ER-32 QF | QF32-DNE-MS40A-050-E-HS-A | 1:1 | EC |
| | 0067732000 | | |
| ER-32 QF | QF32-DNE-MS40A-067-I-HS-A | 1:1 | IC 100 bar |
| | 0067732000 | | |



- OD drill/milling unit (12000 RPM) - QF smart (EU, US, CA, JP)**
- | | | | |
|-----------------|------------------------------|-----|------------|
| ER-32 QF | QF32-DNE-MS40A-067-I-HS-SB-A | 1:1 | IC 100 bar |
| | 0067732000 | | |
| | LI-F12-01 | | |



- OD drill/milling unit (6000 RPM, Heavy Duty)**
- | | | | |
|-----------------|--------------------------------|-----|-----------|
| ER-25 QF | 420125010-40
T32274, T32450 | 1:1 | EC |
| | 0067725000 | | |
| ER-25 QF | 420125011-40
T32287 | 1:1 | IC 80 bar |
| | 0067725000 | | |
| ER-32 QF | 420132010-40
T32475, T32484 | 1:1 | EC |
| | 0067732000 | | |
| ER-32 QF | 420132011-40 | 1:1 | IC 80 bar |
| | 0067732000 | | |

Driven Toolholders - QuickFlex®



- Face drill/milling unit (12000 RPM)**
- | | | | |
|-----------------|---------------------------|-----|------------|
| ER-25 QF | 420525013-40
T32434 | 1:1 | EC |
| | 0067725000 | | |
| ER-25 QF | 420525014-40
T32436 | 1:1 | IC 80 bar |
| | 0067725000 | | |
| ER-32 QF | QF32-DNI-MS40A-085-E-HS-A | 1:1 | EC |
| | 0067732000 | | |
| ER-32 QF | QF32-DNI-MS40A-085-I-HS-A | 1:1 | IC 100 bar |
| | 0067732000 | | |



- Face drill/milling unit (12000 RPM) - QF smart (EU, US, CA, JP)**
- | | | | |
|-----------------|------------------------------|-----|------------|
| ER-32 QF | QF32-DNI-MS40A-085-I-HS-SB-A | 1:1 | IC 100 bar |
| | 0067732000 | | |
| | LI-F12-01 | | |



- Face drill/milling unit (6000 RPM, Heavy Duty)**
- | | | | |
|-----------------|--------------------------------|-----|-----------|
| ER-25 QF | 420525010-40
T32275, T32297 | 1:1 | EC |
| | 0067725000 | | |
| ER-25 QF | 420525011-40
T32288, T32435 | 1:1 | IC 80 bar |
| | 0067725000 | | |
| ER-32 QF | 420532010-40
T32476, T32485 | 1:1 | EC |
| | 0067732000 | | |

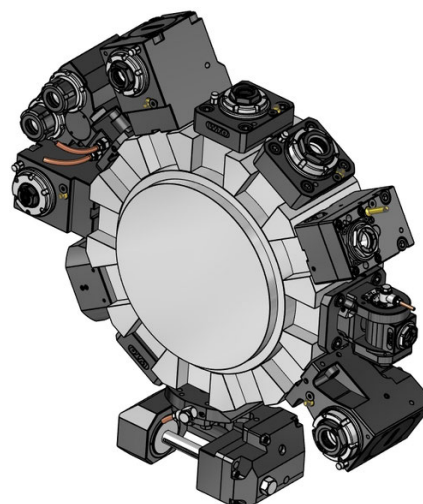
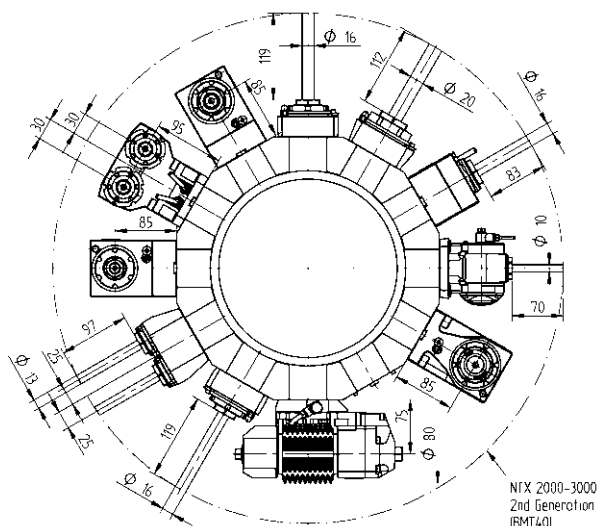

Driven Toolholders - QuickFlex®



**Face back set drill/milling unit, sub spindle
(only for NTX 1000 S2 2nd Generation)**

- | | | | |
|-----------------|--------------|-----|-----------|
| ER-25 QF | 420525047-40 | 1:1 | EC |
| | 0067725010 | | |
| ER-25 QF | 420525048-40 | 1:1 | IC 80 bar |
| | 0067725010 | | |



**Face drill/milling unit, sub spindle (only
for NTX 2000-3000 S2 2nd Generation)**

- | | | | |
|-----------------|--------------|-----|-----------|
| ER-20 QF | 420520016-40 | 1:1 | EC |
| | 0067720000 | | |
| ER-20 QF | 420520017-40 | 1:1 | IC 80 bar |
| | 0067720000 | | |

Driven Toolholders - Enhanced Program

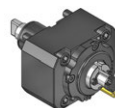

**OD milling unit with combination mill arbor
DIN 6358**

- | | | | |
|---------------|----------------|-----|----|
| Ø 16 | 410216010-40 | 1:1 | EC |
| | 00675000854 | | |
| Ø 22 | 410222016-40 | 1:1 | EC |
| | T32280, T32486 | | |
| | 00675000483 | | |
| Ø 3/4" | 410219003-40 | 1:1 | EC |
| | 00675000483 | | |



OD drill/milling unit, offset

- | | | | |
|--------------|--------------|-----|-----------|
| ER 25 | 410116050-40 | 1:1 | EC |
| | T32488 | | |
| | 00675000932 | | |
| ER 25 | 410116057-40 | 1:1 | IC 80 bar |
| | 00675000932 | | |
| ER 20 | 410113060-40 | 1:2 | EC |
| | 00675000939 | | |
| ER 20 | 410113068-40 | 1:2 | IC 80 bar |
| | 00675000939 | | |
| ER 16 | 410410003-40 | 1:3 | EC |
| | 00675000937 | | |
| ER 16 | 410410004-40 | 1:3 | IC 80 bar |
| | 00675000937 | | |
| ER 25 | 410116051-40 | 2:1 | EC |
| | 00675000932 | | |
| ER 25 | 410116058-40 | 2:1 | IC 80 bar |
| | 00675000932 | | |

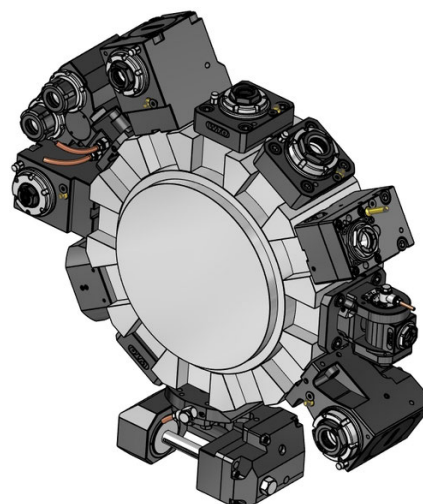
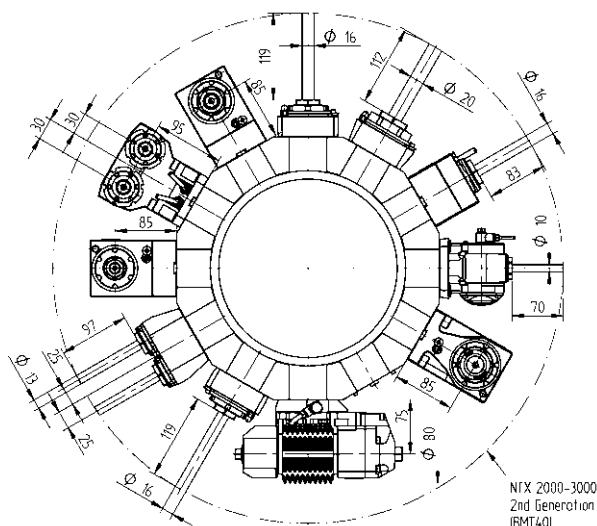

Driven Toolholders - Enhanced Program



OD drill/milling unit, offset (12000 RPM)

- | | | | |
|--------------|--------------|-----|-----------|
| ER 25 | 410116060-40 | 1:1 | EC |
| | 00675000932 | | |
| ER 25 | 410116059-40 | 1:1 | IC 80 bar |
| | 00675000932 | | |



Face drill/milling unit

- | | | | |
|-----------------|--------------------------|-----|------------|
| ER-20 QF | 420520010-40 | 1:2 | EC |
| | 0067720001 | | |
| ER-20 QF | 420520011-40 | 1:2 | IC 80 bar |
| | 0067720001 | | |
| ER 16 | 410810012-40 | 1:3 | EC |
| | 0067825001 | | |
| ER 16 | 410810013-40 | 1:3 | IC 80 bar |
| | 0067825001 | | |
| ER-32 QF | 420532013-40 | 2:1 | EC |
| | 0067732000 | | |
| ER-32 QF | QF32-DNI-MS40A-085-I-T-A | 2:1 | IC 100 bar |
| | 0067732000 | | |



**Face milling unit with combination mill arbor
DIN 6358**

- | | | | |
|---------------|--------------|-----|----|
| Ø 16 | 410616013-40 | 1:1 | EC |
| | 00675000854 | | |
| Ø 22 | 410622030-40 | 1:1 | EC |
| | 00675000483 | | |
| Ø 3/4" | 410619003-40 | 1:1 | EC |
| | 00675000483 | | |

Driven Toolholders - Enhanced Program

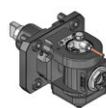

Adjustable angle drill/milling unit

- | | | | |
|--------------|--------------|-----|-----------|
| ER 16 | 411010008-40 | 1:1 | EC |
| | 00675000913 | | |
| ER 16 | 411010009-40 | 1:1 | IC 80 bar |
| | 00675000913 | | |
| ER 11 | 411007001-40 | 1:2 | EC |
| | 00675000914 | | |
| ER 11 | 411007002-40 | 1:2 | IC 80 bar |
| | 00675000914 | | |



Gear hobbing unit

- | | | | |
|------------------|--------------------|-----|----|
| Type 16-1 | 411500017-40 | 1:1 | EC |
| Type 16-1 | 411500018-40 | 2:1 | EC |
| | 00675000954 | | |
| | 160016161 Ø 16 | | |
| | 160022161 Ø 22 | | |
| | 160027161 Ø 27 | | |
| | 160015161 Ø 5/8" | | |
| | 160019161 Ø 3/4" | | |
| | 160025161 Ø 1" | | |
| | 160031161 Ø 1 1/4" | | |
| | 110587 | | |

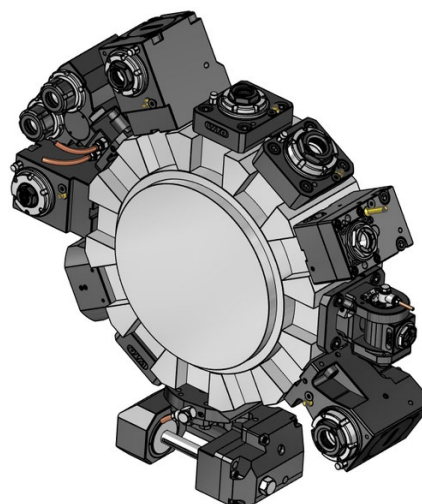
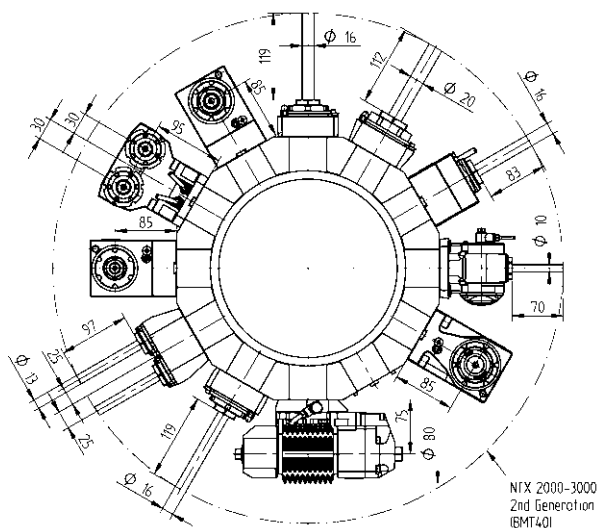

Driven Toolholders - Enhanced Program



OD drill/milling unit, both sides

- | | | | |
|--------------|--------------|-----|-----------|
| ER 20 | 413002015-40 | 1:1 | EC |
| | 00675000947 | | |
| ER 20 | 413002018-40 | 1:1 | IC 80 bar |
| | 00675000947 | | |



OD drill/milling unit, double, Y axis

- | | | | |
|--------------|--------------|-----|-----------|
| ER 20 | 413002014-40 | 1:1 | EC |
| | 00675000947 | | |
| ER 20 | 413002017-40 | 1:1 | IC 80 bar |
| | 00675000947 | | |



2-spindle - Face drill/milling unit, Y axis

- | | | | |
|--------------|--------------|-----|-----------|
| ER 25 | 413502008-40 | 1:1 | EC |
| | 00675000915 | | |
| ER 25 | 413502009-40 | 1:1 | IC 80 bar |
| | 00675000915 | | |

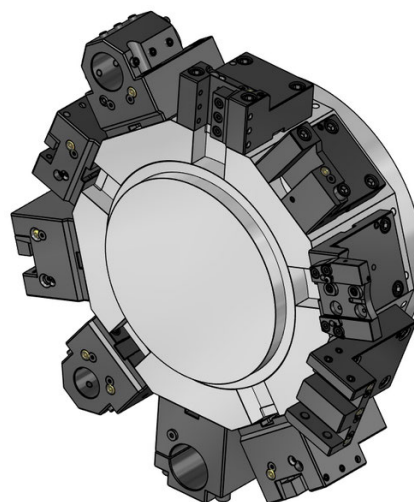
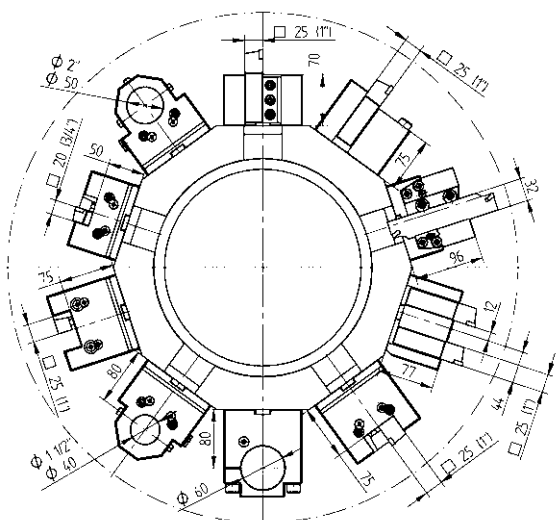

Static Toolholders - Standard Program

Static Toolholders - Standard Program



- OD cutting holder**
- 20 48-T00187
T00187
 - 25 48-T00186
T00186
 - 3/4" 48-T00203
T00203
 - 1" 48-T00202
T00202



- OD cutting holder, HP-IC**
- 25 48-T00186-HP IC 80 bar
T00186
 - 1" 48-T00202-HP IC 80 bar
T00202



- OD cutting holder, both sides**
- 20 48-T00185
T00185
 - 25 48-T00184
T00184
 - 3/4" 48-T00201
T00201
 - 1" 48-T00199
T00199



- OD cutting holder, both sides, HP-IC**
- 25 48-T00184-HP IC 80 bar
T00184
 - 1" 48-T00199-HP IC 80 bar
T00199



- Face cutting holder**
- 20 48-T03006
T03006
 - 25 48-T03005
T03005
 - 3/4" 48-T03014
T03014
 - 1" 48-T03013
T03013



- Face cutting holder, HP-IC**
- 25 48-T03005-HP IC 80 bar
T03005
 - 1" 48-T03013-HP IC 80 bar
T03013



- Cut-off holder, right hand**
- 25 48-T00197
T00197
 - 1" 48-T00198
T00198



- Boring bar holder, LF=80**
- Ø 40 48-T10097
T10097
 - Ø 50 48-T10098
T10098
 - Ø 1 1/2" 48-T10101
T10101
 - Ø 2" 48-T10102
T10102
 - Ø 2 1/2" 48-70080

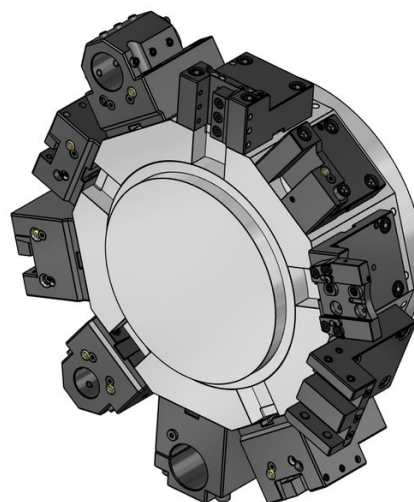
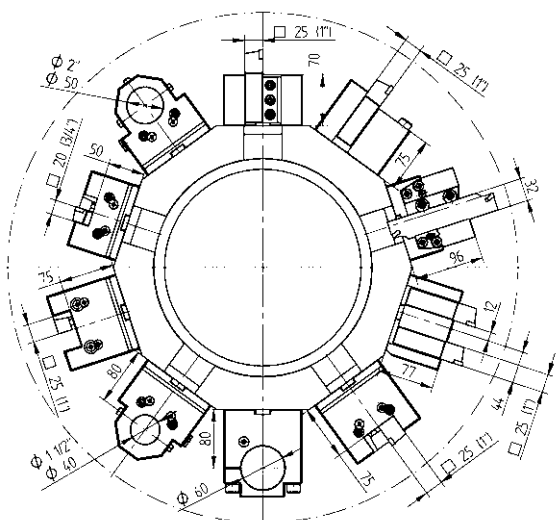

Static Toolholders - Standard Program



Combination toolholder, LF=80

Ø 40	48-T13128 T13128	IC 80 bar
Ø 50	48-T13139 T13139	IC 80 bar
Ø 1 1/2"	48-T13130 T13130	IC 80 bar
Ø 2"	48-T13140 T13140	IC 80 bar

Static Toolholders - Enhanced Program



OD cutting holder, right hand, long, HP-IC

25	48-T00385-HP T00385	IC 80 bar
1"	48-T00386-HP T00386	IC 80 bar



OD cutting holder, left hand, long, HP-IC

25	48-T00387-HP T00387	IC 80 bar
1"	48-T00388-HP T00388	IC 80 bar



OD cutting holder, double, Y axis

25(1")	48-71865 T00206, T00210
---------------	----------------------------

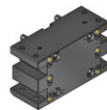

OD cutting holder, both sides, double, Y axis

25(1")	48-71863 T00253, T00258
---------------	----------------------------



Cut-off holder, adjustable

SH 32	48-98901
--------------	----------



Cut-off holder, adjustable, HP-IC

SH 32	48-102262R	IC 80 bar
SH 32	48-102262L	IC 80 bar

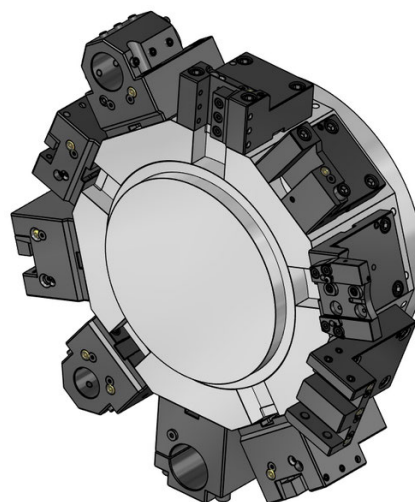
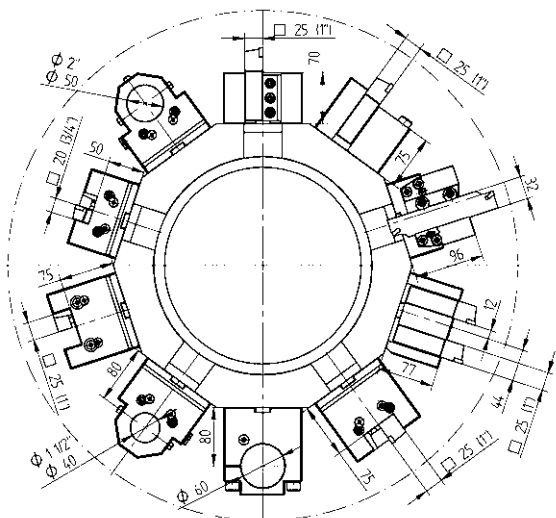

Static Toolholders - Enhanced Program



SH 32

Cut-off holder, adjustable, extended

48-77478



Ø 40

48-T10136
T10136

Ø 50

48-T10137
T10137

Ø 60

48-70811

Ø 1 1/2"

48-T10143
T10143

Ø 2"

48-T10142
T10142

Boring bar holder, with slot



VDI 30

48-77127

VDI 40

48-72984

VDI adapter, left



VDI 30

48-74796

VDI 40

48-77955

VDI adapter, right



48-81080

Boring bar holder, blank

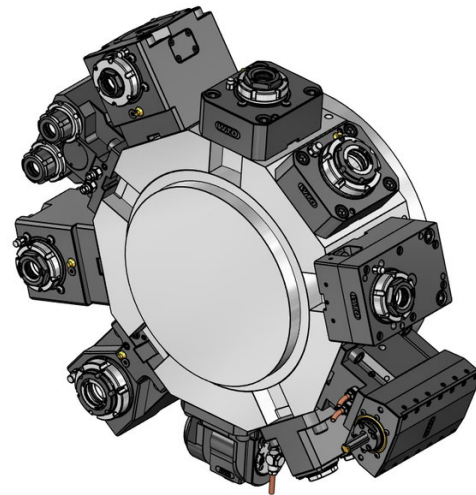
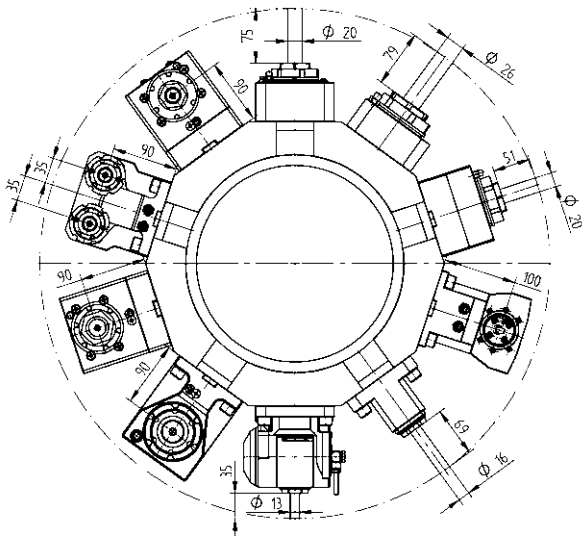

Driven Toolholders - QuickFlex®

Driven Toolholders - QuickFlex®



OD drill/milling unit (12000 RPM)

- ER-32 QF** QF32-DNE-MS60A-072-E-HS-A 1:1 EC
0067732000
- ER-32 QF** QF32-DNE-MS60A-072-I-HS-A 1:1 IC 100 bar
0067732000



OD drill/milling unit (12000 RPM) - QF smart (EU, US, CA, JP)

- ER-32 QF** QF32-DNE-MS60A-072-I-HS-SB-A 1:1 IC 100 bar
0067732000
- LI-F12-01



OD drill/milling unit (6000 RPM, Heavy Duty)

- ER-32 QF** 420132011-60 T32232, T32478 1:1 IC 80 bar
0067732000
- ER-40 QF** 420140010-60 T32213 1:1 EC
0067740000
- ER-40 QF** 420140011-60 T32234 1:1 IC 80 bar
0067740000



Face drill/milling unit (12000 RPM)

- ER-32 QF** QF32-DNI-MS60A-090-E-HS-A 1:1 EC
0067732000
- ER-32 QF** QF32-DNI-MS60A-090-I-HS-A 1:1 IC 100 bar
0067732000



Face drill/milling unit (12000 RPM) - QF smart (EU, US, CA, JP)

- ER-32 QF** QF32-DNI-MS60A-090-I-HS-SB-A 1:1 IC 100 bar
0067732000
- LI-F12-01



Face drill/milling unit (6000 RPM, Heavy Duty)

- ER-40 QF** 420540012-60 T32214 1:1 EC
0067740000
- ER-40 QF** 420540013-60 T32235 1:1 IC 80 bar
0067740000

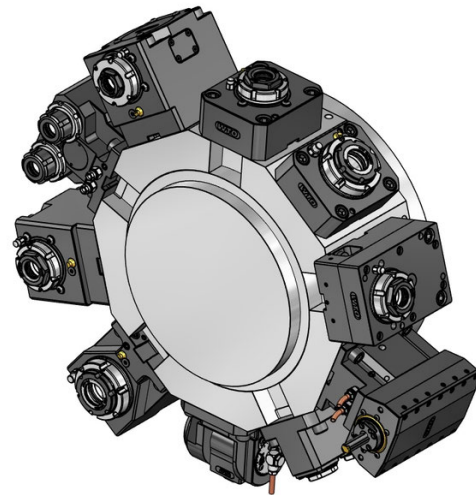
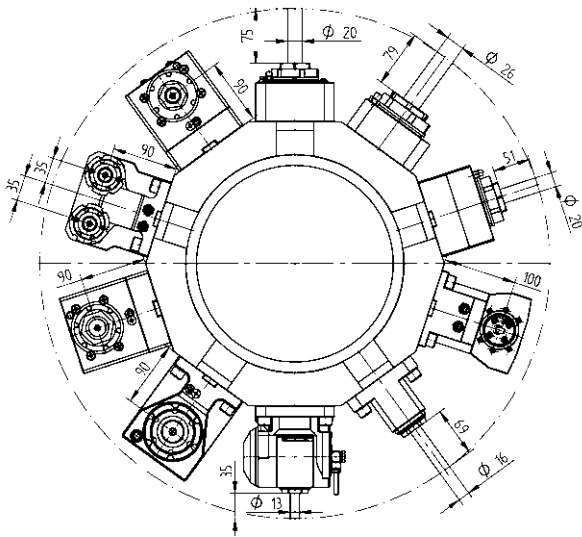

Driven Toolholders - Enhanced Program



**OD milling unit with combination mill arbor
DIN 6358**

Ø 16	410216000-60 00675000854	1:1	EC
Ø 22	410222007-60 T32268 00675000483	1:1	EC
Ø 27	410227008-60 00675000245	1:1	EC
Ø 3/4"	410219000-60 00675000483	1:1	EC
Ø 1"	410225000-60 T32217 00675000483	1:1	EC



OD drill/milling unit, offset

ER-32 QF	420132019-60 0067732000	1:1	EC
ER-32 QF	420132020-60 0067732000	1:1	IC 80 bar
ER-25 QF	420125010-60 0067725001	1:2	EC
ER-25 QF	420125011-60 0067725001	1:2	IC 80 bar
ER-32 QF	420132021-60 0067732000	2:1	EC
ER-32 QF	420132022-60 0067732000	2:1	IC 80 bar



Face drill/milling unit

ER-25 QF	QF25-DNI-MS60A-090-E-S-A 0067725001	1:2	EC
ER-25 QF	QF25-DNI-MS60A-090-I-S-A 0067725001	1:2	IC 100 bar
ER-40 QF	420540014-60 0067740000	2:1	EC
ER-40 QF	420540015-60 0067740000	2:1	IC 80 bar

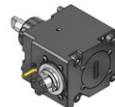

**Face milling unit with combination mill arbor
DIN 6358**

Ø 22	M022-DNI-MS60A-090-E-T-A 00675000483	2:1	EC
Ø 27	M027-DNI-MS60A-090-E-T-A 00675000245	2:1	EC
Ø 1"	M100-DNI-MS60A-090-E-T-A 00675000483	2:1	EC



Adjustable angle drill/milling unit

ER 20	411013009-60 T32474 00675000928	1:1	EC
ER 20	411013010-60 00675000928	1:1	IC 80 bar
ER 16	411010001-60 00675000936	1:2	EC
ER 16	411010002-60 00675000936	1:2	IC 80 bar

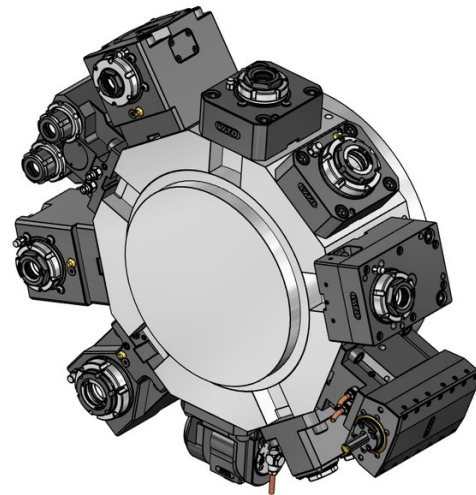
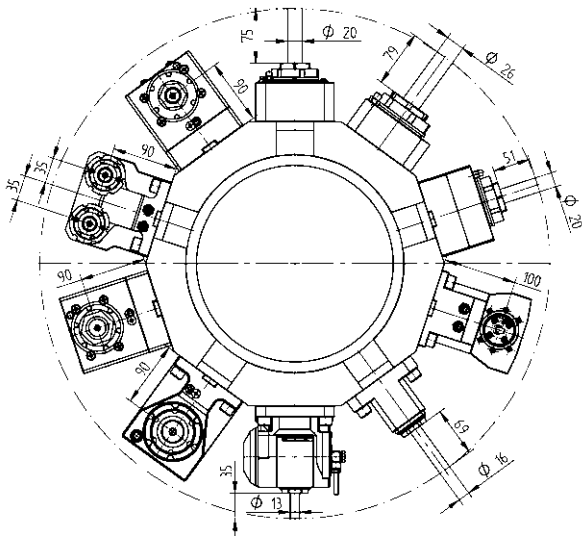

Driven Toolholders - Enhanced Program



ER 25 **OD drill/milling unit, both sides**
 413002001-60 1:1 EC
 00675000907



ER 25 **OD drill/milling unit, double, Y axis**
 413002000-60 1:1 EC
 T32267
 00675000907

ER 25 413002012-60 1:1 IC 80 bar
 00675000907

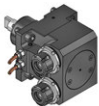

ER 25 **2-spindle - Face drill/milling unit, Y axis**
 413502000-60 1:1 EC
 T32264
 00675000915

ER 25 413502002-60 1:1 IC 80 bar
 00675000915

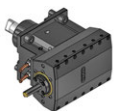

Type 32 **Broaching unit for ID and OD**
 414532000-60 1:1 EC
Type 52 414552000-60 1:1 EC

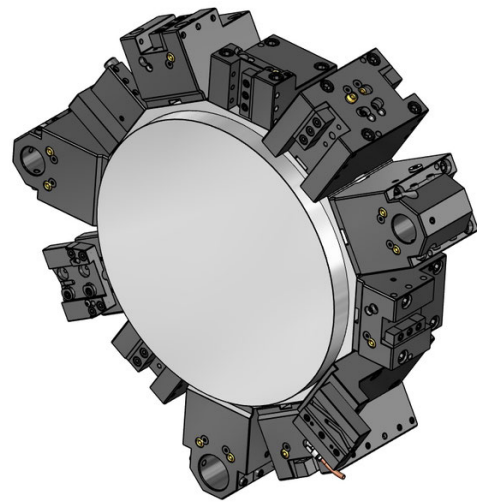
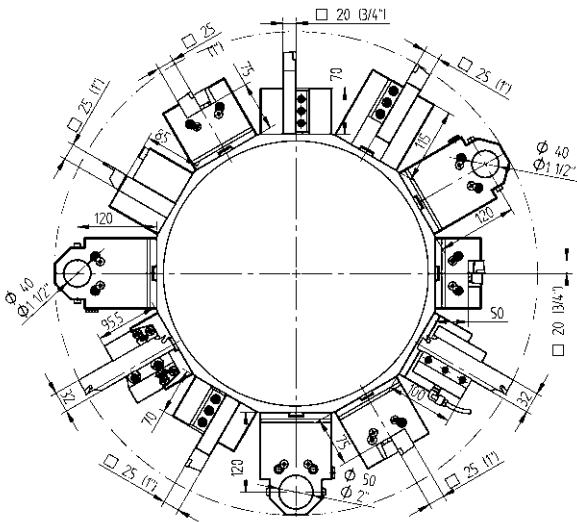

Static Toolholders - Standard Program



- OD cutting holder**
- 20 48-T00187
T00187
 - 25 48-T00186
T00186
 - 3/4" 48-T00203
T00203
 - 1" 48-T00202
T00202



- OD cutting holder, HP-IC**
- 25 48-T00186-HP IC 80 bar
T00186
 - 1" 48-T00202-HP IC 80 bar
T00202



- OD cutting holder, both sides**
- 20 48-T00185
T00185
 - 25 48-T00184
T00184
 - 3/4" 48-T00201
T00201
 - 1" 48-T00199
T00199



- OD cutting holder, both sides, HP-IC**
- 25 48-T00184-HP IC 80 bar
T00184
 - 1" 48-T00199-HP IC 80 bar
T00199

Static Toolholders - Standard Program



- OD cutting holder, both sides, long**
- 25 48-T00237
T00237
 - 1" 48-78257



- Face cutting holder**
- 20 48-T03006
T03006
 - 25 48-T03005
T03005
 - 3/4" 48-T03014
T03014
 - 1" 48-T03013
T03013



- Face cutting holder, HP-IC**
- 25 48-T03005-HP IC 80 bar
T03005
 - 1" 48-T03013-HP IC 80 bar
T03013



- Cut-off holder, right hand**
- 25 48-T00197
T00197
 - 1" 48-T00198
T00198

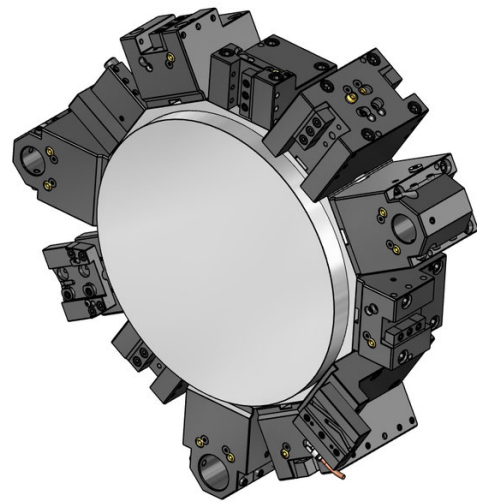
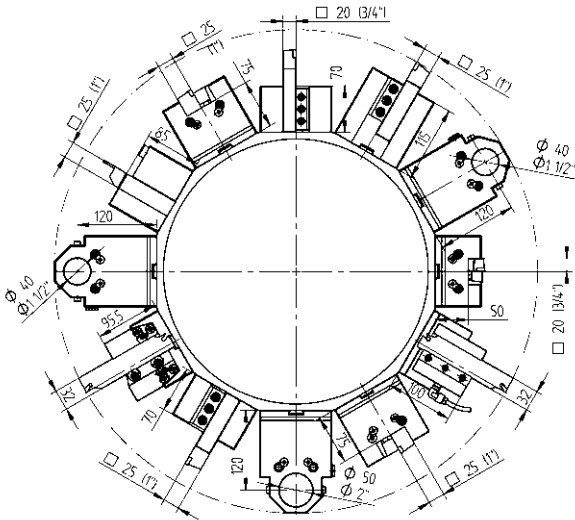

Static Toolholders - Standard Program



Boring bar holder, LF=120

- Ø 40 48-T10113
T10113
- Ø 50 48-T10114
T10114
- Ø 1 1/2" 48-T10134
T10134
- Ø 2" 48-T10135
T10135



Combination toolholder, LF=120

- Ø 40 48-T13131 IC 80 bar
T13131
- Ø 50 48-77902 IC 80 bar
- Ø 1 1/2" 48-T13137 IC 80 bar
T13137
- Ø 2" 48-77901 IC 80 bar

Static Toolholders - Enhanced Program



OD cutting holder, right hand, long, HP-IC

- 25 48-T00385-HP IC 80 bar
T00385
- 1" 48-T00386-HP IC 80 bar
T00386



OD cutting holder, left hand, long, HP-IC

- 25 48-T00387-HP IC 80 bar
T00387
- 1" 48-T00388-HP IC 80 bar
T00388



OD cutting holder, extended

- 25 48-76267
- 1" 48-81553

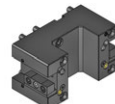

OD cutting holder, both sides, extended

- 25 48-81627
- 1" 48-82499



Face cutting holder, both sides

- 25 48-78995
- 1" 48-78996



Cut-off holder, adjustable

- SH 32 48-98901

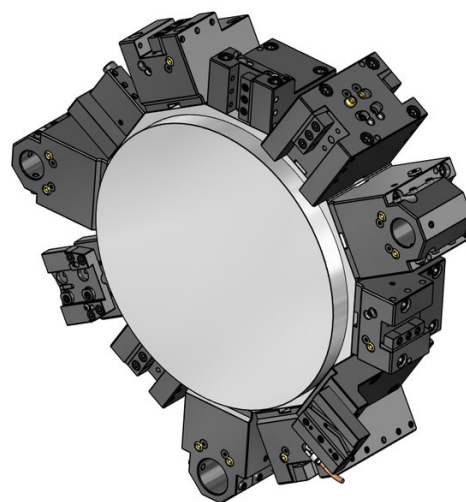
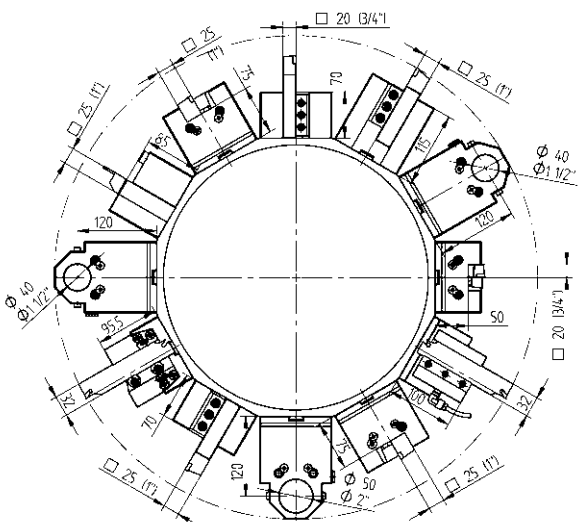

Static Toolholders - Enhanced Program

Static Toolholders - Enhanced Program



Cut-off holder, adjustable, HP-IC
SH 32 48-102262R IC 80 bar
SH 32 48-102262L IC 80 bar



Cut-off holder, adjustable, extended
SH 32 48-77478



Collet face drill holder
ER 32 48-94564 IC 80 bar
 107532000
ER 40 48-94566 IC 80 bar
 107540000



Collet face drill holder, both sides
ER 32 48-94565 IC 80 bar
 107532000
ER 40 48-94567 IC 80 bar
 107540000



VDI adapter, left
VDI 30 48-77127
VDI 40 48-72984



VDI adapter, right
VDI 30 48-74796
VDI 40 48-77955



Boring bar holder, blank
 48-81081

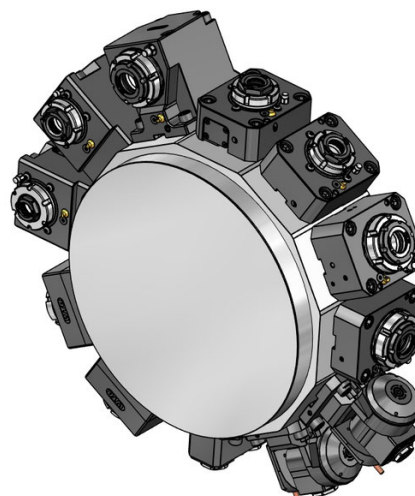
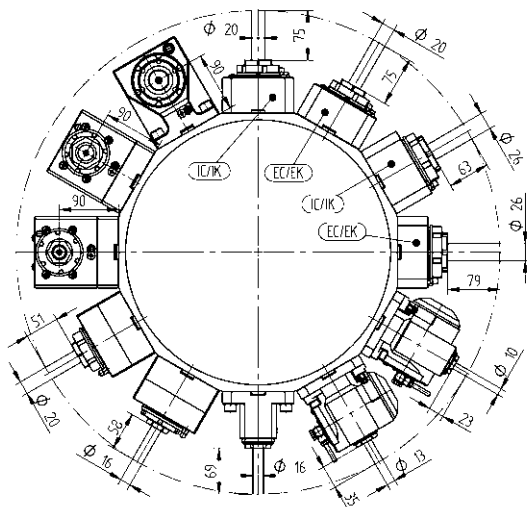

Driven Toolholders - QuickFlex®



OD drill/milling unit (12000 RPM)

ER-32 QF QF32-DNE-MS60A-072-E-HS-A 1:1 EC
0067732000

ER-32 QF QF32-DNE-MS60A-072-I-HS-A 1:1 IC 100 bar
0067732000



OD drill/milling unit (12000 RPM) - QF smart (EU, US, CA, JP)

ER-32 QF QF32-DNE-MS60A-072-I-HS-SB-A 1:1 IC 100 bar
0067732000

LI-F12-01



OD drill/milling unit (6000 RPM, Heavy Duty)

ER-32 QF 420132011-60 1:1 IC 80 bar
T32232, T32478
0067732000

ER-40 QF 420140010-60 1:1 EC
T32213
0067740000

ER-40 QF 420140011-60 1:1 IC 80 bar
T32234
0067740000



Face drill/milling unit (12000 RPM)

ER-32 QF QF32-DNI-MS60A-090-E-HS-A 1:1 EC
0067732000

ER-32 QF QF32-DNI-MS60A-090-I-HS-A 1:1 IC 100 bar
0067732000

Driven Toolholders - QuickFlex®



Face drill/milling unit (12000 RPM) - QF smart (EU, US, CA, JP)

ER-32 QF QF32-DNI-MS60A-090-I-HS-SB-A 1:1 IC 100 bar
0067732000

LI-F12-01



Face drill/milling unit (6000 RPM, Heavy Duty)

ER-40 QF 420540012-60 1:1 EC
T32214

0067740000

ER-40 QF 420540013-60 1:1 IC 80 bar
T32235

0067740000



Face drill/milling unit, both sides (6000 RPM, Heavy Duty)

ER-32 QF 420532019-60 1:1 EC
T32216

0067732000

ER-40 QF 420540016-60 1:1 EC
T32248

0067740000

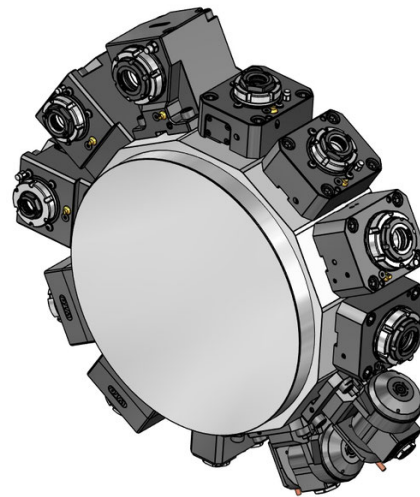
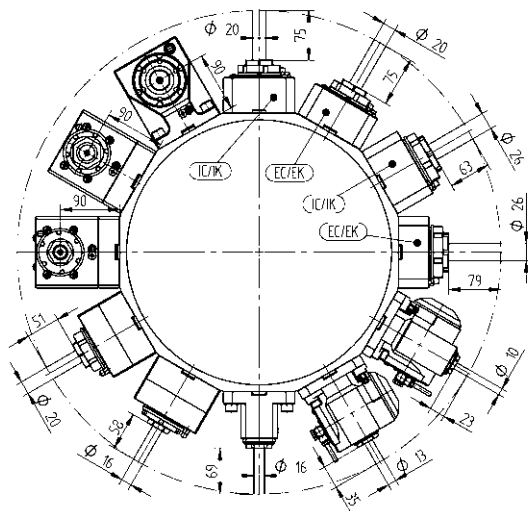

Driven Toolholders - Enhanced Program



**OD milling unit with combination mill arbor
DIN 6358**

Ø 16	410216000-60 00675000854	1:1	EC
Ø 22	410222007-60 T32268 00675000483	1:1	EC
Ø 27	410227008-60 00675000245	1:1	EC
Ø 3/4"	410219000-60 00675000483	1:1	EC
Ø 1"	410225000-60 T32217 00675000483	1:1	EC



OD drill/milling unit, offset

ER-32 QF	420132019-60 0067732000	1:1	EC
ER-32 QF	420132020-60 0067732000	1:1	IC 80 bar
ER-25 QF	420125010-60 0067725001	1:2	EC
ER-25 QF	420125011-60 0067725001	1:2	IC 80 bar
ER-32 QF	420132021-60 0067732000	2:1	EC
ER-32 QF	420132022-60 0067732000	2:1	IC 80 bar



Face drill/milling unit

ER-25 QF	QF25-DNI-MS60A-090-E-S-A 0067725001	1:2	EC
ER-25 QF	QF25-DNI-MS60A-090-I-S-A 0067725001	1:2	IC 100 bar
ER-40 QF	420540014-60 0067740000	2:1	EC
ER-40 QF	420540015-60 0067740000	2:1	IC 80 bar

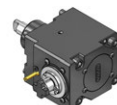

**Face milling unit with combination mill arbor
DIN 6358**

Ø 22	M022-DNI-MS60A-090-E-T-A 00675000483	2:1	EC
Ø 27	M027-DNI-MS60A-090-E-T-A 00675000245	2:1	EC
Ø 1"	M100-DNI-MS60A-090-E-T-A 00675000483	2:1	EC



Adjustable angle drill/milling unit

ER 20	411013009-60 T32474 00675000928	1:1	EC
ER 20	411013010-60 00675000928	1:1	IC 80 bar
ER 16	411010001-60 00675000936	1:2	EC
ER 16	411010002-60 00675000936	1:2	IC 80 bar

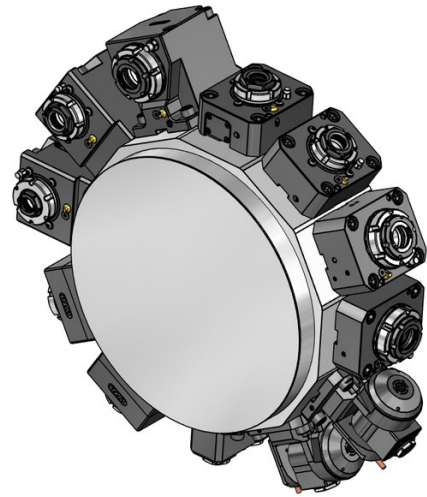
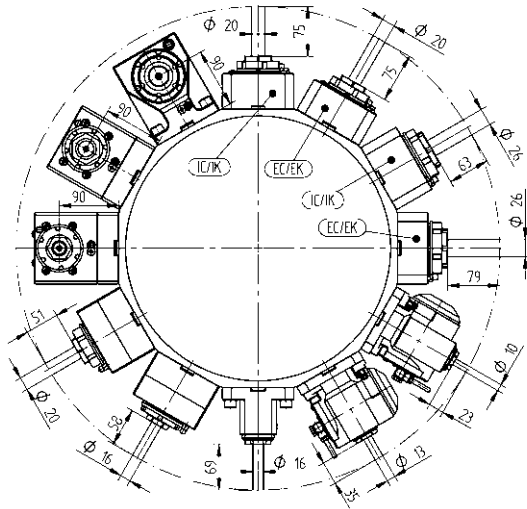

Driven Toolholders - Enhanced Program



ER 25

OD drill/milling unit, both sides

413002001-60

1:1 EC

00675000907

Standard reduction sleeves - cylindrical



Reduction sleeve Ø 20

240020006	ø 6
240020008	ø 8
240020010	ø 10
240020012	ø 12
240020014	ø 14
240020016	ø 16



Reduction sleeve Ø 25

240025006	ø 6
240025008	ø 8
240025010	ø 10
240025012	ø 12
240025014	ø 14
240025016	ø 16
240025020	ø 20



Reduction sleeve Ø 32

240032006	ø 6
240032008	ø 8
240032010	ø 10
240032012	ø 12
240032014	ø 14
240032016	ø 16
240032018	ø 18
240032020	ø 20
240032025	ø 25



Reduction sleeve Ø 40

240040006	ø 6
240040008	ø 8
240040010	ø 10
240040012	ø 12
240040014	ø 14
240040016	ø 16
240040020	ø 20
240040025	ø 25
240040032	ø 32



Reduction sleeve Ø 50

240050010	ø 10
240050012	ø 12
240050016	ø 16
240050020	ø 20
240050025	ø 25
240050032	ø 32
240050040	ø 40

Standard reduction sleeves - cylindrical



Reduction sleeve Ø 3/4"

2400075025	ø 1/4"
2400075032	ø 5/16"
2400075038	ø 3/8"
2400075050	ø 1/2"
2400075063	ø 5/8"



Reduction sleeve Ø 1"

2400100025	ø 1/4"
2400100031	ø 5/16"
2400100038	ø 3/8"
2400100050	ø 1/2"
2400100063	ø 5/8"
2400100075	ø 3/4"



Reduction sleeve Ø 1 1/4"

2400125038	ø 3/8"
2400125050	ø 1/2"
2400125063	ø 5/8"
2400125075	ø 3/4"
2400125088	ø 7/8"
2400125100	ø 1"



Reduction sleeve Ø 1 1/2"

2400150038	ø 3/8"
2400150050	ø 1/2"
2400150063	ø 5/8"
2400150075	ø 3/4"
2400150088	ø 7/8"
2400150100	ø 1"
2400150125	ø 1 1/4"



Reduction sleeve Ø 2"

2400200050	ø 1/2"
2400200063	ø 5/8"
2400200075	ø 3/4"
2400200088	ø 7/8"
2400200100	ø 1"
2400200125	ø 1 1/4"
2400200150	ø 1 1/2"
2400200175	ø 1 3/4"

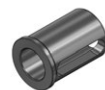

Reduction sleeve Ø 3"

2400300075	ø 3/4"
2400300100	ø 1"
2400300125	ø 1 1/4"
2400300150	ø 1 1/2"
2400300200	ø 2"
2400300250	ø 2 1/2"

Standard reduction sleeves - cylindrical, with slot

Standard reduction sleeves - morse taper



Reduction sleeve Ø 25

240125006	ø 6
240125008	ø 8
240125010	ø 10
240125012	ø 12
240125014	ø 14
240125015	ø 15
240125016	ø 16
240125020	ø 20



Reduction sleeve Ø 32

240132008	ø 8
240132010	ø 10
240132012	ø 12
240132015	ø 15
240132016	ø 16
240132020	ø 20
240132025	ø 25



Reduction sleeve Ø 40

240140010	ø 10
240140012	ø 12
240140015	ø 15
240140016	ø 16
240140020	ø 20
240140025	ø 25
240140032	ø 32



Reduction sleeve Ø 50

240150020	ø 20
240150025	ø 25
240150032	ø 32
240150040	ø 40

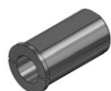

Reduction sleeve Ø 60

240160032	ø 32
240160040	ø 40
240160050	ø 50



Reduction sleeve Ø 32

240532001	MT 1
240532002	MT 2
240532003	MT 3



Reduction sleeve Ø 40

240540001	MT 1
240540002	MT 2
240540003	MT 3
240540004	MT 4

Reduction sleeves for boring bar holders - cylindrical



Reduction sleeve Ø 25

24-T20180	ø 8
24-T20182	ø 10
24-T20184	ø 12
24-T20186	ø 16
24-T20188	ø 20



Reduction sleeve Ø 32

24-T20112	ø 8
24-T20114	ø 10
24-T20116	ø 12
24-T20118	ø 16
24-T20120	ø 20
24-T20122	ø 25



Reduction sleeve Ø 40

24-T20086	ø 8
24-T20088	ø 10
24-T20090	ø 12
24-T20092	ø 16
24-T20094	ø 20
24-T20096	ø 25
24-T20098	ø 32



Reduction sleeve Ø 50

24-T20160	ø 10
24-T20162	ø 12
24-T20164	ø 16
24-T20166	ø 20
24-T20168	ø 25
24-T20170	ø 32
24-T20172	ø 40



Reduction sleeve Ø 60

24-T20136	ø 32
24-T20138	ø 40
24-T20140	ø 50



Reduction sleeve Ø 1"

24-T20181	ø 3/8"
24-T20183	ø 1/2"
24-T20185	ø 5/8"
24-T20187	ø 3/4"



Reduction sleeve Ø 1 1/4"

24-T20115	ø 3/8"
24-T20117	ø 1/2"
24-T20119	ø 5/8"
24-T20121	ø 3/4"
24-T20123	ø 1"

Reduction sleeves for boring bar holders - cylindrical



Reduction sleeve Ø 1 1/2"

24-T20089	ø 3/8"
24-T20091	ø 1/2"
24-T20093	ø 5/8"
24-T20095	ø 3/4"
24-T20097	ø 1"
24-T20099	ø 1 1/4"



Reduction sleeve Ø 2"

24-T20163	ø 1/2"
24-T20165	ø 5/8"
24-T20167	ø 3/4"
24-T20169	ø 1"
24-T20171	ø 1 1/4"
24-T20173	ø 1 1/2"

Reduction sleeves for boring bar holders - cylindrical, extended



Reduction sleeve Ø 32

24-T20124	ø 8
24-T20126	ø 10
24-T20128	ø 12
24-T20130	ø 16



Reduction sleeve Ø 40

24-T20106	ø 8
24-T20108	ø 10
24-T20110	ø 12
24-T20194	ø 16
24-T20196	ø 20
24-T20216	ø 25



Reduction sleeve Ø 1 1/4"

24-T20127	ø 3/8"
24-T20129	ø 1/2"
24-T20131	ø 5/8"



Reduction sleeve Ø 1 1/2"

24-T20109	ø 3/8"
24-T20111	ø 1/2"
24-T20195	ø 5/8"
24-T20197	ø 3/4"

Reduction sleeves for boring bar holders - morse taper



Reduction sleeve Ø 40

24-T22046	MT 2
24-T22042	MT 3

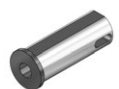

Reduction sleeve Ø 50

24-T22044	MT 4
-----------	------

Collets DIN 6499B (ER/ESX)



ER 11	mm	inch
190011000	∅ 7-0.5	∅ 0.276-0.020
190011010	∅ 1-0.5	∅ 0.039-0.020
190011015	∅ 1.5-1	∅ 0.059-0.039
190011020	∅ 2-1.5	∅ 0.079-0.059
190011025	∅ 2.5-2	∅ 0.098-0.079
190011030	∅ 3-2.5	∅ 0.118-0.098
190011035	∅ 3.5-3	∅ 0.138-0.118
190011040	∅ 4-3.5	∅ 0.158-0.138
190011045	∅ 4.5-4	∅ 0.177-0.158
190011050	∅ 5-4.5	∅ 0.197-0.177
190011055	∅ 5.5-5	∅ 0.217-0.197
190011060	∅ 6-5.5	∅ 0.236-0.217
190011065	∅ 6.5-6	∅ 0.256-0.236
190011070	∅ 7-6.5	∅ 0.276-0.256



ER 16	mm	inch
190016000	∅ 10-0.5	∅ 0.394-0.020
190016010	∅ 1-0.5	∅ 0.039-0.020
190016020	∅ 2-1	∅ 0.079-0.039
190016030	∅ 3-2	∅ 0.118-0.079
190016040	∅ 4-3	∅ 0.158-0.118
190016050	∅ 5-4	∅ 0.197-0.158
190016060	∅ 6-5	∅ 0.236-0.197
190016070	∅ 7-6	∅ 0.276-0.236
190016080	∅ 8-7	∅ 0.315-0.276
190016090	∅ 9-8	∅ 0.354-0.315
190016100	∅ 10-9	∅ 0.394-0.354



ER 20	mm	inch
190020000	∅ 13-1	∅ 0.512-0.039
190020010	∅ 1-0.5	∅ 0.039-0.020
190020020	∅ 2-1	∅ 0.079-0.039
190020030	∅ 3-2	∅ 0.118-0.079
190020040	∅ 4-3	∅ 0.157-0.118
190020050	∅ 5-4	∅ 0.197-0.157
190020060	∅ 6-5	∅ 0.236-0.197
190020070	∅ 7-6	∅ 0.276-0.236
190020080	∅ 8-7	∅ 0.315-0.276
190020090	∅ 9-8	∅ 0.354-0.315
190020100	∅ 10-9	∅ 0.394-0.354
190020110	∅ 11-10	∅ 0.433-0.394
190020120	∅ 12-11	∅ 0.472-0.433
190020130	∅ 13-12	∅ 0.512-0.472

Collets DIN 6499B (ER/ESX)



ER 25	mm	inch
190025000	∅ 16-1	∅ 0.630-0.039
190025010	∅ 1-0.5	∅ 0.039-0.020
190025020	∅ 2-1	∅ 0.079-0.039
190025030	∅ 3-2	∅ 0.118-0.079
190025040	∅ 4-3	∅ 0.157-0.118
190025050	∅ 5-4	∅ 0.197-0.157
190025060	∅ 6-5	∅ 0.236-0.197
190025070	∅ 7-6	∅ 0.276-0.236
190025080	∅ 8-7	∅ 0.315-0.276
190025090	∅ 9-8	∅ 0.354-0.315
190025100	∅ 10-9	∅ 0.394-0.354
190025110	∅ 11-10	∅ 0.433-0.394
190025120	∅ 12-11	∅ 0.472-0.433
190025130	∅ 13-12	∅ 0.512-0.472
190025140	∅ 14-13	∅ 0.551-0.512
190025150	∅ 15-14	∅ 0.591-0.551
190025160	∅ 16-15	∅ 0.630-0.591



ER 32	mm	inch
190032000	∅ 20-2	∅ 0.787-0.079
190032020	∅ 2-1	∅ 0.079-0.039
190032030	∅ 3-2	∅ 0.118-0.079
190032040	∅ 4-3	∅ 0.157-0.118
190032050	∅ 5-4	∅ 0.197-0.157
190032060	∅ 6-5	∅ 0.236-0.197
190032070	∅ 7-6	∅ 0.276-0.236
190032080	∅ 8-7	∅ 0.315-0.276
190032090	∅ 9-8	∅ 0.354-0.315
190032100	∅ 10-9	∅ 0.394-0.354
190032110	∅ 11-10	∅ 0.433-0.394
190032120	∅ 12-11	∅ 0.472-0.433
190032130	∅ 13-12	∅ 0.512-0.472
190032140	∅ 14-13	∅ 0.551-0.512
190032150	∅ 15-14	∅ 0.591-0.551
190032160	∅ 16-15	∅ 0.630-0.591
190032170	∅ 17-16	∅ 0.669-0.630
190032180	∅ 18-17	∅ 0.709-0.669
190032190	∅ 19-18	∅ 0.748-0.709
190032200	∅ 20-19	∅ 0.787-0.748

Collets DIN 6499B (ER/ESX)



ER 40	mm	inch
190040000	ø 26-3	ø 1.024-0.118
190040030	ø 3-2	ø 0.118-0.079
190040040	ø 4-3	ø 0.157-0.118
190040050	ø 5-4	ø 0.197-0.157
190040060	ø 6-5	ø 0.236-0.197
190040070	ø 7-6	ø 0.276-0.236
190040080	ø 8-7	ø 0.315-0.276
190040090	ø 9-8	ø 0.354-0.315
190040100	ø 10-9	ø 0.394-0.354
190040110	ø 11-10	ø 0.433-0.394
190040120	ø 12-11	ø 0.472-0.433
190040130	ø 13-12	ø 0.512-0.472
190040140	ø 14-13	ø 0.551-0.512
190040150	ø 15-14	ø 0.591-0.551
190040160	ø 16-15	ø 0.630-0.591
190040170	ø 17-16	ø 0.669-0.630
190040180	ø 18-17	ø 0.709-0.669
190040190	ø 19-18	ø 0.748-0.709
190040200	ø 20-19	ø 0.787-0.748
190040210	ø 21-20	ø 0.827-0.787
190040220	ø 22-21	ø 0.866-0.827
190040230	ø 23-22	ø 0.906-0.866
190040240	ø 24-23	ø 0.945-0.906
190040250	ø 25-24	ø 0.984-0.945
190040260	ø 26-25	ø 1.024-0.984



ER 50	mm	inch
190050000	ø 34-10	ø 1.339-0.394
190050060	ø 6-4	ø 0.236-0.157
190050080	ø 8-6	ø 0.315-0.236
190050100	ø 10-8	ø 0.394-0.315
190050120	ø 12-10	ø 0.472-0.394
190050140	ø 14-12	ø 0.551-0.472
190050160	ø 16-14	ø 0.630-0.551
190050180	ø 18-16	ø 0.709-0.630
190050200	ø 20-18	ø 0.787-0.709
190050220	ø 22-20	ø 0.866-0.787
190050240	ø 24-22	ø 0.945-0.866
190050260	ø 26-24	ø 1.024-0.945
190050280	ø 28-26	ø 1.102-1.024
190050300	ø 30-28	ø 1.181-1.102
190050320	ø 32-30	ø 1.260-1.181
190050340	ø 32-30	ø 1.260-1.181

Collets DIN 6499D (ER/ESX) - sealed, for IC



ER 11	
191011030	ø 3
191011040	ø 4
191011050	ø 5
191011060	ø 6



ER 16	
191016000	ø 3-10
191016030	ø 3
191016040	ø 4
191016050	ø 5
191016060	ø 6
191016070	ø 7
191016080	ø 8
191016090	ø 9
191016100	ø 10



ER 20	
191020000	ø 3-12
191020030	ø 3
191020040	ø 4
191020050	ø 5
191020060	ø 6
191020070	ø 7
191020080	ø 8
191020090	ø 9
191020100	ø 10
191020110	ø 11
191020120	ø 12



ER 25	
191025000	ø 4-16
191025030	ø 3
191025040	ø 4
191025050	ø 5
191025060	ø 6
191025070	ø 7
191025080	ø 8
191025090	ø 9
191025100	ø 10
191025110	ø 11
191025120	ø 12
191025130	ø 13
191025140	ø 14
191025150	ø 15
191025160	ø 16

Collets DIN 6499D (ER/ESX) - sealed, for IC

Collets DIN 6499D (ER/DM) - metallic sealed, for IC



ER 32

191032000	ø 4-20
191032030	ø 3
191032040	ø 4
191032050	ø 5
191032060	ø 6
191032070	ø 7
191032080	ø 8
191032090	ø 9
191032100	ø 10
191032110	ø 11
191032120	ø 12
191032130	ø 13
191032140	ø 14
191032150	ø 15
191032160	ø 16
191032170	ø 17
191032180	ø 18
191032190	ø 19
191032200	ø 20



ER 40

191040060	ø 6
191040080	ø 8
191040100	ø 10
191040120	ø 12
191040140	ø 14
191040160	ø 16
191040180	ø 18
191040200	ø 20
191040220	ø 22
191040250	ø 25



ER 11

191111013-in	ø 0.125
191111019-in	ø 0.188
191111025-in	ø 0.25



ER 16

191116001-in	ø 0.125-0.375
191116013-in	ø 0.125
191116019-in	ø 0.188
191116025-in	ø 0.25
191116031-in	ø 0.313
191116038-in	ø 0.375



ER 20

191120001-in	ø 0.125-0.5
191120013-in	ø 0.125
191120019-in	ø 0.188
191120025-in	ø 0.25
191120031-in	ø 0.313
191120038-in	ø 0.375
191120044-in	ø 0.438
191120050-in	ø 0.5



ER 25

191125001-in	ø 0.25-0.625
191125025-in	ø 0.25
191125031-in	ø 0.313
191125038-in	ø 0.375
191125044-in	ø 0.438
191125050-in	ø 0.5
191125056-in	ø 0.563
191125063-in	ø 0.625



ER 32

191132001-in	ø 0.25-0.75
191132025-in	ø 0.25
191132031-in	ø 0.313
191132038-in	ø 0.375
191132044-in	ø 0.438
191132050-in	ø 0.5
191132056-in	ø 0.563
191132063-in	ø 0.625
191132069-in	ø 0.688
191132075-in	ø 0.75

Collets DIN 6499D (ER/DM) - metallic sealed,
for IC

**ER 40**

191140025-in	ø 0.25
191140031-in	ø 0.313
191140038-in	ø 0.375
191140044-in	ø 0.438
191140050-in	ø 0.5
191140056-in	ø 0.563
191140063-in	ø 0.625
191140069-in	ø 0.688
191140075-in	ø 0.75
191140088-in	ø 0.875
191140100-in	ø 1



Quality without compromise.

All manufacturing steps are based on highest precision.

According to our own device that for the manufacture of high precision tooling systems high precision machine tools are essential we only use the latest machine tool technology to manufacture our parts.

At WTO not only the final products but also all manufacturing steps are checked and documented. All our products are measured on high precision 3D-coordinate-measuring machines.



WTO Werkzeug-
Einrichtungen GmbH
Neuer Hohdammweg 1
77797 Ohlsbach
Germany

WTO Inc.
13900-F South Lakes Dr.
Charlotte, NC 28273
USA

WTO Asia
WTO Precision Tool Holders
(Shanghai) Co. Ltd.
Room 109-110, Building 2
No. 228 Banting Road
Jiuting Town,
Songjiang District
201615 Shanghai
China

Our distribution partners. Competence right there.

Australia

Dimac Tooling Ltd.
sales@dimac.com.au

Brazil

TF2
tfdois@tfdois.com.br

Canada

Mittmann Industrial Inc.
info@mittmann.com

China

Shanghai Gangde
wtocando@yahoo.com

Czech Republic

ALBA precision, spol. s.r.o.
info@albaprecision.cz

Denmark

AVN Teknik A/S
cjo@avn.dk

Finland

Suomen Terätuonti Oy
myynti@stt.as

France, east

Alexandre Mathelin
alm@wto.de

France, west

Christophe Archambault
car@wto.de

Great Britain

Cutwel Ltd.
sales@cutwel.net

Hungary

Prevotex Hungary Kft.
info@prevotex.hu

India

Ulhas Patil
u.patil@wto-asia.com

Israel

E.Y.A.R. Ltd.
boris@eyar.co.il

Italy

Prymark srl
commerciale@prymark.it

Japan

NK Works Co. Ltd.
k_samba@nk-works.co.jp

Korea

WTO Office Korea
is.chon@wto-korea.com

Mexico

Workholding Engineering De México
info@wem.com.mx

Netherlands

Toologic BeNeLux B.V.
info@toologic-benelux.nl

Norway

Helge Karlsen Verktøy og Maskin AS
hkvm@hkvm.no

Poland

ARCO Andrzej Rudenko
info@arcotools.pl

Romania

SC Elif Trading SRL
bulent.ozkan@eliftrading.com

Slovakia

ALBA precision s.r.o.
albaprecision@albaprecision.sk

Spain

ITALMATIC, S.A.
italmatic@italmatic.es

Sweden

Bonthron & Ewing AB
info@bonthron-ewing.se

Switzerland

Utilis AG
info@utilis.com

Taiwan

Kaiko Co., Ltd.
info@kaiko.com.tw

Turkey

MYK CNC MAKINA SAN. VE
huseyin.tatlidil@mykcnc.com.tr

Ukraine

„LLC“ SPA Stankopromimport
info@phoenix-ua.com