

# DMG MORI

# WTO

## Programma Portautensili

NZ DUE, TRE, QUATTRO (BMT40)  
NZ DUE, TRE, QUATTRO (BMT42/64)  
NZ DUE, TRE, QUATTRO (VDI25)  
NZ DUE, TRE, QUATTRO (VDI30)  
NZX 1500, 2000 (16 ST)  
NZX 2500 (BMT60)  
NZX 2500 (torretta 2 = BMT40)  
NZX 4000  
NZX 6000

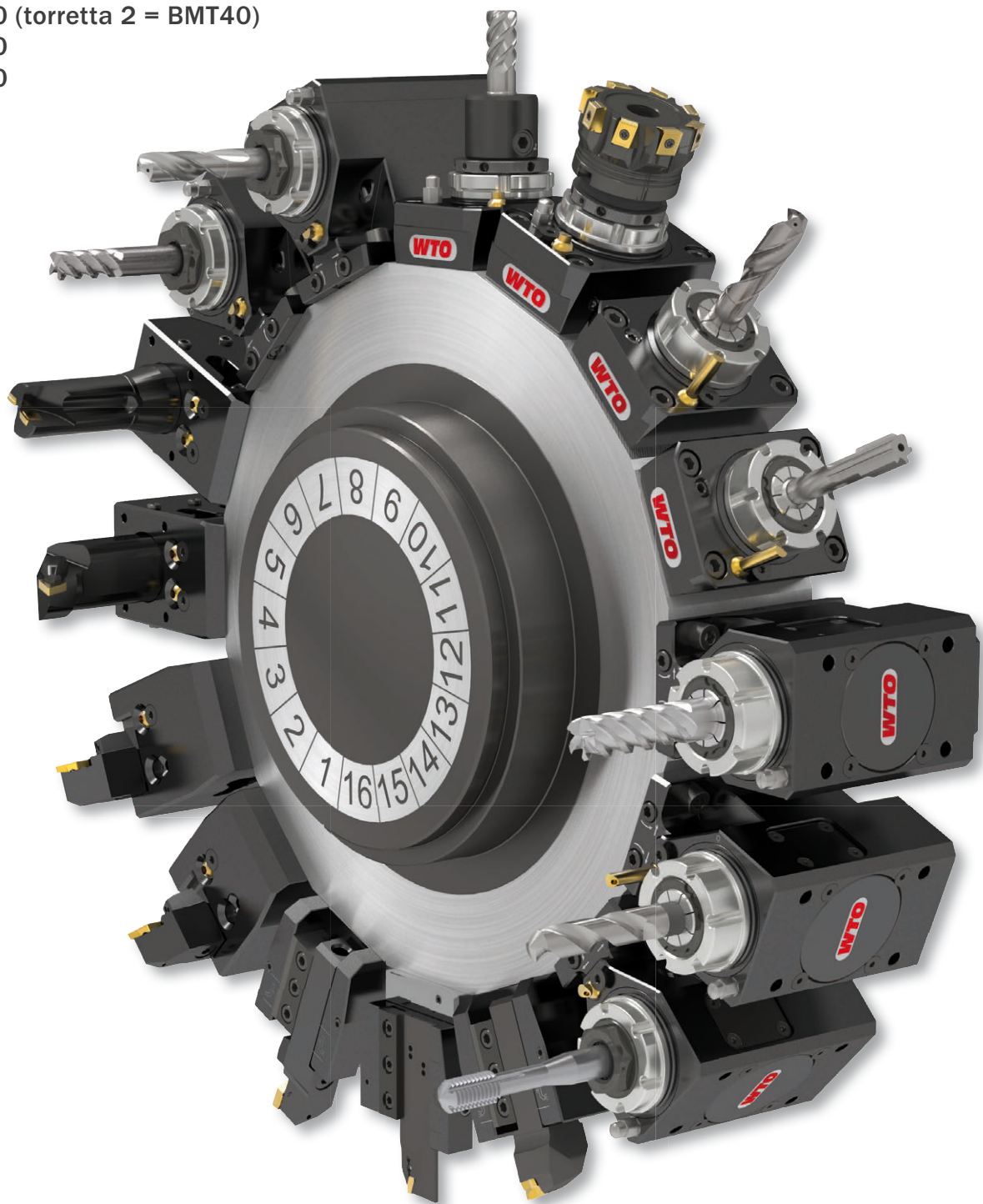

# DMG MORI



## QuickFlex®

Nuovo sistema a cambio rapido per elevate prestazioni e precisione.

Minimo investimento, massima versatilità.

progettato  
per



NZ DUE, TRE, QUATTRO (BMT40)	Pagina 4 - 9
NZ DUE, TRE, QUATTRO (BMT42/64)	Pagina 10 - 11
NZ DUE, TRE, QUATTRO (VDI25)	Pagina 12 - 17
NZ DUE, TRE, QUATTRO (VDI30)	Pagina 18 - 25
NZX 1500, 2000 (16 ST)	Pagina 26 - 32
NZX 2500 (BMT60)	Pagina 33 - 37
NZX 2500 (torretta 2 = BMT40)	Pagina 38 - 42
NZX 4000	Pagina 43 - 44
NZX 6000	Pagina 45 - 46
Bussole di riduzione	Pagina 47 - 49
Pinze	Pagina 50 - 52

**EC = adduzione esterna refrigerante**  
**HP-IC = adduzione interna refrigerante alta pressione attraverso l'utensile**  
**IC 80 bar = adduzione esterna ed interna refrigerante**  
Massima pressione refrigerante = 80 bar  
**IC 30 bar = adduzione esterna ed interna refrigerante**  
Massima pressione refrigerante = 30 bar  
usare solo refrigerante filtrato (dim. Max. =50 µm)  
non utilizzare senza refrigerante!  
non utilizzare per lavorazione di ghise

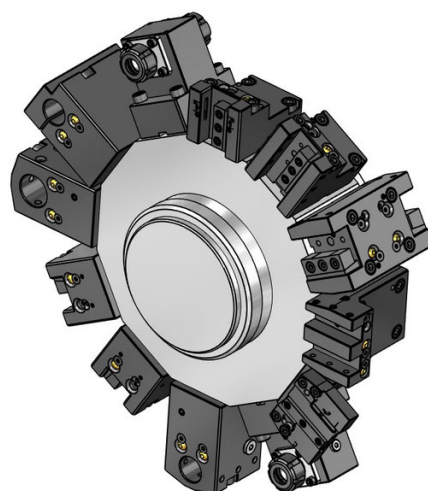
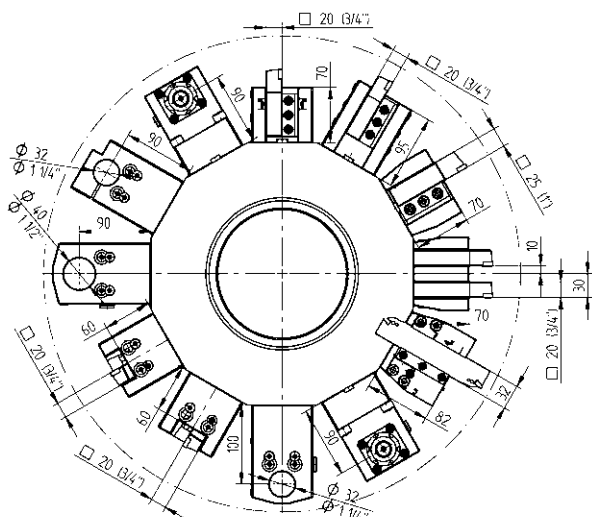

Portautensili statici - Programma standard



**Portautensile corto**  
 20 48-T00224  
 T00224  
 25 48-T00267  
 T00267



**Portautensile corto, HP-IC**  
 20 48-T00224-HP IC 80 bar  
 T00224  
 25 48-T00267-HP IC 80 bar  
 T00267



**Portautensile lungo**  
 20 48-T00225  
 T00225



**Portautensile per lavorazione su mandrino e contromandrino, corto**  
 20 48-T00228  
 T00228  
 25 48-86523



**Portautensile per lavorazione su mandrino e contromandrino, corto, HP-IC**  
 20 48-T00228-HP IC 80 bar  
 T00228  
 25 48-86523-HP IC 80 bar

Portautensili statici - Programma standard



**Portautensile per lavorazione su mandrino e contromandrino, lungo**  
 20 48-T00226  
 T00226



**Portautensile per esterni**  
 25 48-T03024  
 T03024



**Portautensile per esterni, HP-IC**  
 20 48-T03017-HP IC 80 bar  
 T03017



**Portautensile da taglio, destro**  
 20 48-T00251  
 T00251  
 25 48-T00268  
 T00268, T00356



**Portabareno**  
 Ø 32 48-T10115  
 T10115



**Portautensile combinato**  
 Ø 32 48-T13132 IC 80 bar  
 T13132  
 Ø 40 48-77999 IC 80 bar

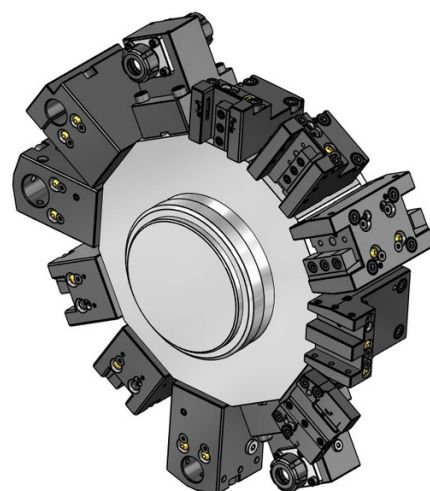
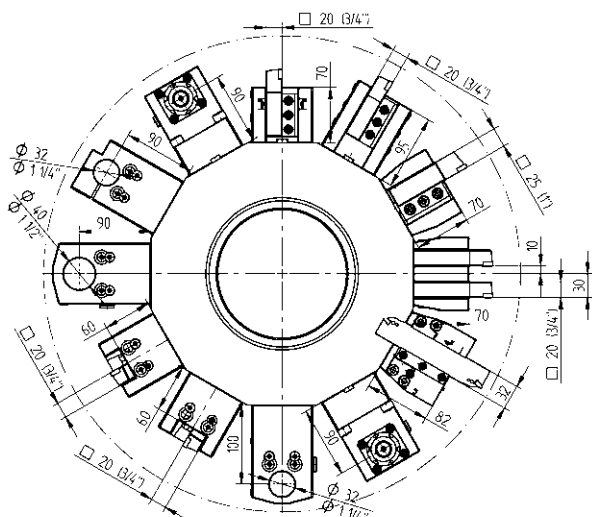

Portautensili statici - Estensione del programma



**Portautensile doppio, asse Y**  
20 (3/4") 48-77726



**Portautensile per lavorazione su mandrino e contromandrino, doppio, asse Y**  
20 (3/4") 48-77727



**Portautensile per esterni doppio**  
20 48-79608



**Portautensile da taglio, con regolazione**  
SH 32 48-98891



**Portautensile da taglio, con regolazione, HP-IC**  
SH 32 48-102261R IC 80 bar  
SH 32 48-102261L IC 80 bar



**Portabareno con serraggio a morsetto**  
Ø 32 48-82057  
Ø 40 48-82058

Portautensili statici - Estensione del programma



**Portapinzze di foratura**  
ER 25 48-107230 IC 80 bar  
107525000

ER 32 48-81031 IC 80 bar  
107532000



**Portautensile di foratura per lavorazione su mandrino e contromandrino**  
ER 25 48-107227 IC 80 bar  
107525000

ER 32 48-80509 IC 80 bar  
107532000



**Portabareno semilavorato**  
48-80506

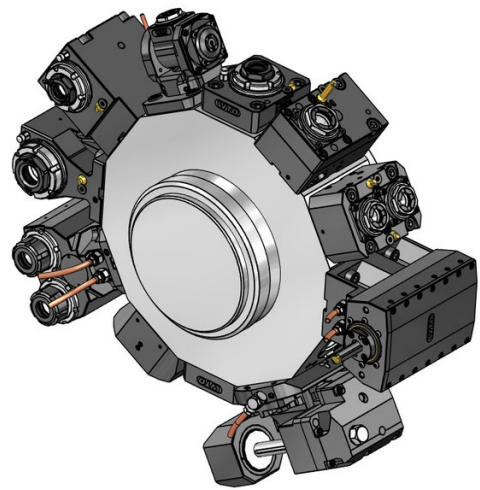
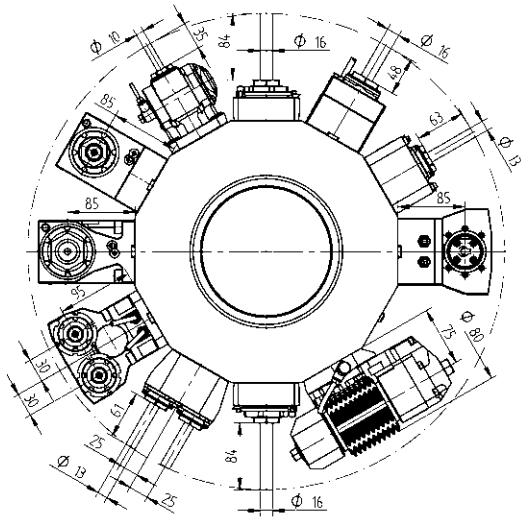

Portautensili Rotanti - QuickFlex®



**Portautensile rotante di foratura/fresatura (12000 RPM)**

<b>ER-25 QF</b>	420125012-40 T32433	1:1	EC
	🔧 0067725000		
<b>ER-25 QF</b>	420125013-40	1:1	IC 80 bar
	🔧 0067725000		
<b>ER-32 QF</b>	QF32-DNE-MS40A-050-E-HS-A	1:1	EC
	🔧 0067732000		
<b>ER-32 QF</b>	QF32-DNE-MS40A-067-I-HS-A	1:1	IC 100 bar
	🔧 0067732000		



**Portautensile rotante di foratura/fresatura (12000 RPM) - QF smart (UE, US, CA, JP)**

<b>ER-32 QF</b>	QF32-DNE-MS40A-067-I-HS-SB-A	1:1	IC 100 bar
	🔧 0067732000		
	📄 LI-F12-01		



**Portautensile rotante di foratura/fresatura (6000 RPM, Heavy Duty)**

<b>ER-25 QF</b>	420125010-40 T32274, T32450	1:1	EC
	🔧 0067725000		
<b>ER-25 QF</b>	420125011-40 T32287	1:1	IC 80 bar
	🔧 0067725000		
<b>ER-32 QF</b>	420132010-40 T32475, T32484	1:1	EC
	🔧 0067732000		
<b>ER-32 QF</b>	420132011-40	1:1	IC 80 bar
	🔧 0067732000		

Portautensili Rotanti - QuickFlex®



**Portautensile rotante di foratura/fresatura (12000 RPM)**

<b>ER-25 QF</b>	420525013-40 T32434	1:1	EC
	🔧 0067725000		
<b>ER-25 QF</b>	420525014-40 T32436	1:1	IC 80 bar
	🔧 0067725000		
<b>ER-32 QF</b>	QF32-DNI-MS40A-085-E-HS-A	1:1	EC
	🔧 0067732000		
<b>ER-32 QF</b>	QF32-DNI-MS40A-085-I-HS-A	1:1	IC 100 bar
	🔧 0067732000		



**Portautensile rotante di foratura/fresatura (12000 RPM) - QF smart (UE, US, CA, JP)**

<b>ER-32 QF</b>	QF32-DNI-MS40A-085-I-HS-SB-A	1:1	IC 100 bar
	🔧 0067732000		
	📄 LI-F12-01		



**Portautensile rotante di foratura/fresatura (6000 RPM, Heavy Duty)**

<b>ER-25 QF</b>	420525010-40 T32275, T32297	1:1	EC
	🔧 0067725000		
<b>ER-25 QF</b>	420525011-40 T32288, T32435	1:1	IC 80 bar
	🔧 0067725000		
<b>ER-32 QF</b>	420532010-40 T32476, T32485	1:1	EC
	🔧 0067732000		

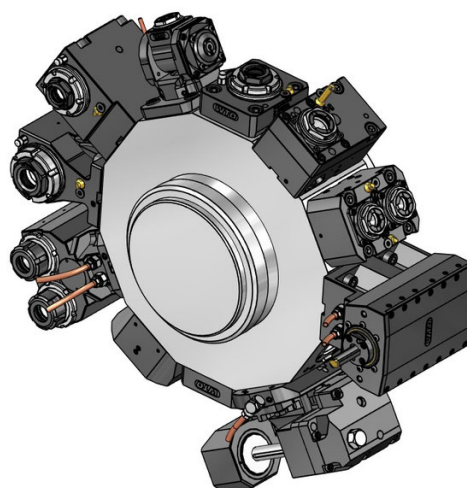
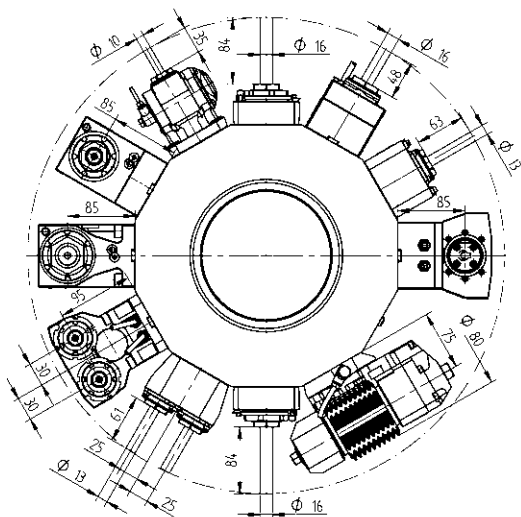

Portautensili Rotanti - QuickFlex®



**Portautensile rotante di foratura/fresatura, per lavorazione su mandrino e contromandrino (12000 RPM)**

- ER-25 QF 420525049-40 1:1 EC  
0067725000
- ER-32 QF 420532148-40 1:1 EC  
0067732000



**Portautensile rotante di foratura/fresatura, per lavorazione su mandrino e contromandrino (6000 RPM, Heavy Duty)**

- ER-25 QF 420525012-40 1:1 EC  
T32276, T32437  
0067725000
- ER-32 QF 420532012-40 1:1 EC  
0067732000

Portautensili Rotanti - Estensione del programma

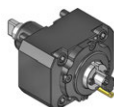

**Portautensile rotante di fresatura con attacco combinato DIN 6358**

- Ø 16 410216010-40 1:1 EC  
00675000854
- Ø 22 410222016-40 1:1 EC  
T32280, T32486  
00675000483



**Portautensile rotante di foratura/fresatura, disassato**

- ER 25 410116050-40 1:1 EC  
T32488  
00675000932
- ER 25 410116057-40 1:1 IC 80 bar  
00675000932
- ER 20 410113060-40 1:2 EC  
00675000939
- ER 20 410113068-40 1:2 IC 80 bar  
00675000939
- ER 16 410410003-40 1:3 EC  
00675000937
- ER 16 410410004-40 1:3 IC 80 bar  
00675000937
- ER 25 410116051-40 2:1 EC  
00675000932
- ER 25 410116058-40 2:1 IC 80 bar  
00675000932

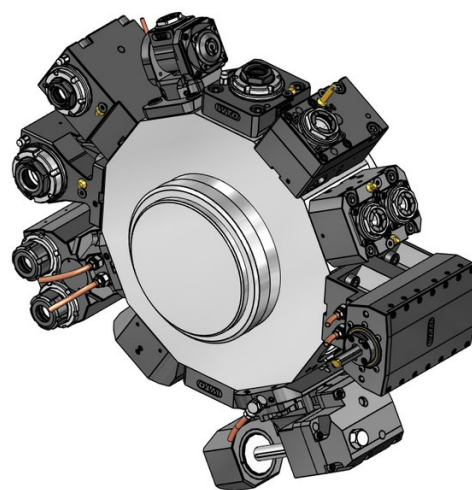
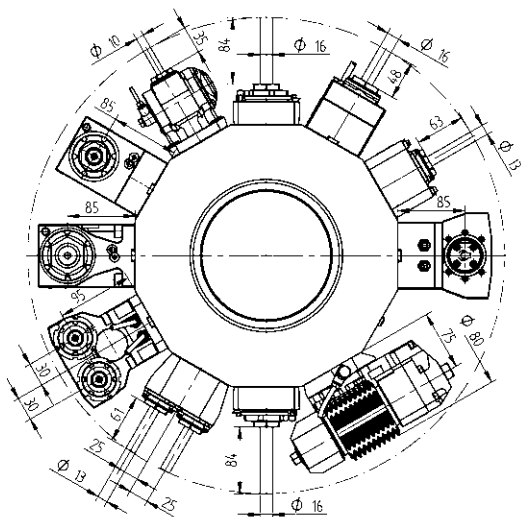

Portautensili Rotanti - Estensione del programma

Portautensili Rotanti - Estensione del programma



**Portautensile rotante di foratura/fresatura, disassato (12000 RPM)**

- ER 25** 410116060-40 1:1 EC  
00675000932
- ER 25** 410116059-40 1:1 IC 80 bar  
00675000932



**Portautensile rotante arretrato di foratura/fresatura**

- ER 25** 410516153-40 1:1 EC  
00675000801
- ER 25** 410516154-40 1:1 IC 80 bar  
00675000801



**Portautensile rotante di foratura/fresatura**

- ER-20 QF** 420520010-40 1:2 EC  
0067720001
- ER-20 QF** 420520011-40 1:2 IC 80 bar  
0067720001
- ER 16** 410810012-40 1:3 EC  
0067825001
- ER 16** 410810013-40 1:3 IC 80 bar  
0067825001
- ER-32 QF** 420532013-40 2:1 EC  
0067732000
- ER-32 QF** QF32-DNI-MS40A-085-I-T-A 2:1 IC 100 bar  
0067732000



**Portautensile rotante orientabile di foratura/fresatura**

- ER 16** 411010008-40 1:1 EC  
00675000913
- ER 16** 411010009-40 1:1 IC 80 bar  
00675000913
- ER 11** 411007001-40 1:2 EC  
00675000914
- ER 11** 411007002-40 1:2 IC 80 bar  
00675000914



**Portautensile rotante con attacco portafrese combinato DIN 6358**

- Ø 16** 410616013-40 1:1 EC  
00675000854
- Ø 22** 410622030-40 1:1 EC  
00675000483



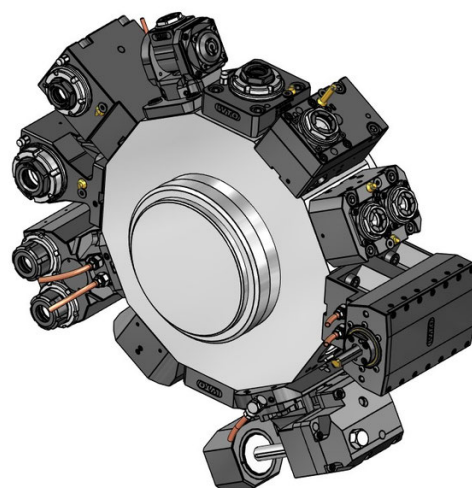
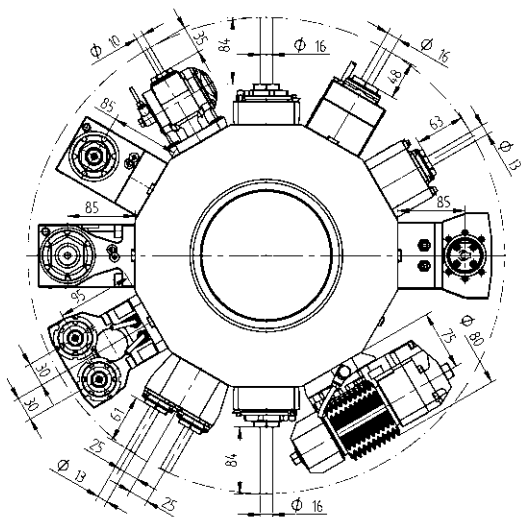

Portautensili Rotanti - Estensione del programma

Portautensili Rotanti - Estensione del programma



**Unità porta creatore**

<b>Tipo 16-1</b>	411500017-40	1:1	EC
<b>Tipo 16-1</b>	411500018-40	2:1	EC
	00675000954		
	160016161 Ø 16		
	160022161 Ø 22		
	160027161 Ø 27		
	160015161 Ø 5/8"		
	160019161 Ø 3/4"		
	160025161 Ø 1"		
	160031161 Ø 1 1/4"		
	110587		

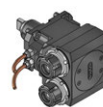

**Portautensile rotante di foratura/fresatura a 2 uscite, asse Y**

<b>ER 25</b>	413502008-40	1:1	EC
	00675000915		
<b>ER 25</b>	413502009-40	1:1	IC 80 bar
	00675000915		

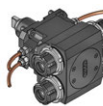

**Portautensile rotante di foratura/fresatura a 2 uscite, per lavorazione su mandrino e contromandrino, asse Y**

<b>ER 25</b>	413502007-40	1:1	EC
	00675000915		



**Unità di brocciatura per interni ed esterni**

<b>Tipo 32</b>	414532000-40	1:1	EC
----------------	--------------	-----	----



**Portautensile rotante di foratura e fresatura, per lavorazione su mandrino e contromandrino**

<b>ER 20</b>	413002015-40	1:1	EC
	00675000947		
<b>ER 20</b>	413002018-40	1:1	IC 80 bar
	00675000947		



**Portautensile rotante di foratura/fresatura - doppio, asse Y**

<b>ER 20</b>	413002014-40	1:1	EC
	00675000947		
<b>ER 20</b>	413002017-40	1:1	IC 80 bar
	00675000947		

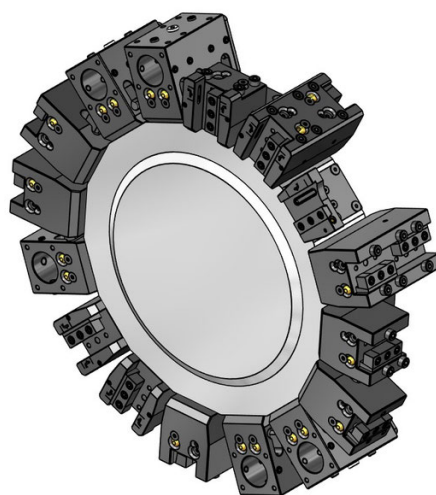
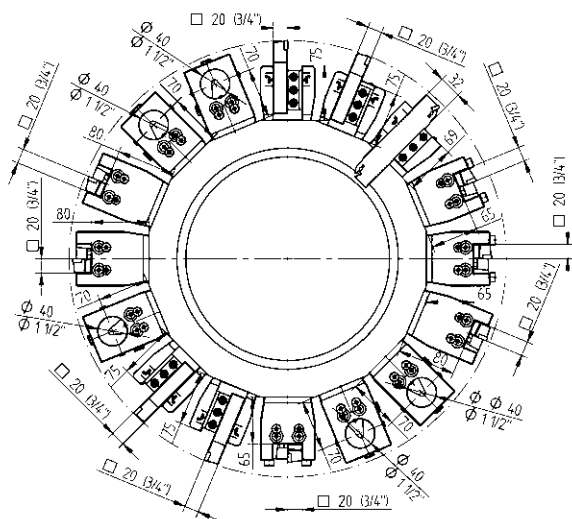

Portautensili statici - Programma standard

Portautensili statici - Estensione del programma



**Portautensile, HP-IC**

20 S020-TNE-MS42A-075-I-A IC 80 bar



**Portautensile per lavorazione su mandrino e contromandrino, HP-IC**

20 S020-TNE-MS42A-075-I-DT-A IC 80 bar

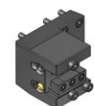

**Portautensile per esterni**

20 S020-TNI-MS42A-087-E-A

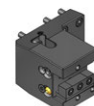

**Portautensile per esterni**

20 S020-TNI-MS42A-100-E-A



**Portautensile per esterni doppio**

20 S020-TNI-MS42A-087-E-DT-A

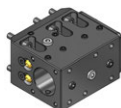

**Portautensile combinato, universale**

Ø 40 D040-TNI-MS42A-070-I-DT-A IC 80 bar

241140020 ER32

241140026 ER40



**Portautensile da taglio, con regolazione**

SH 32 SH32-TNE-MS42A-077-E-A



**Portautensile da taglio, con regolazione, HP-IC**

SH 32 SH32-TRE-MS42A-077-I-A IC 80 bar

SH 32 SH32-TLE-MS42A-077-I-A IC 80 bar

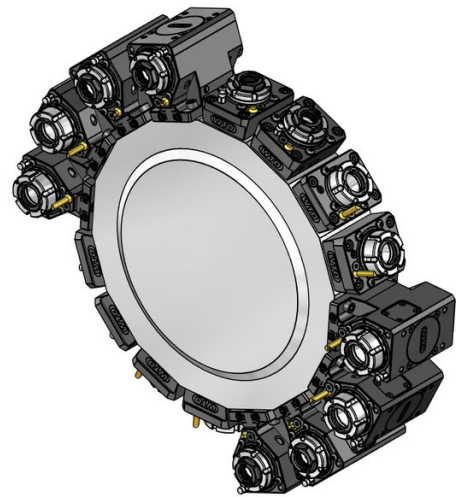
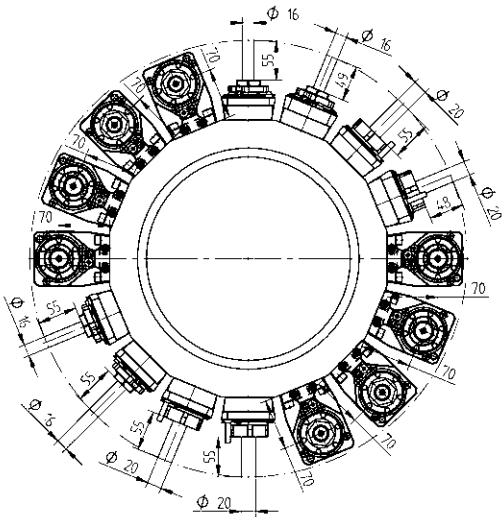

Portautensili Rotanti - QuickFlex®

Portautensili Rotanti - Estensione del programma



**Portautensile rotante di foratura/fresatura (12000 RPM)**

- |                 |                        |     |            |
|-----------------|------------------------|-----|------------|
| <b>ER-25 QF</b> | QF25-DNE-MS42A-047-E-A | 1:1 | EC         |
|                 | 0067725000             |     |            |
| <b>ER-25 QF</b> | QF25-DNE-MS42A-053-I-A | 1:1 | IC 100 bar |
|                 | 0067725000             |     |            |



**Portautensile rotante di foratura/fresatura (12000 RPM)**

- |              |                        |     |            |
|--------------|------------------------|-----|------------|
| <b>ER 32</b> | ER32-DNE-MS42A-055-E-A | 1:1 | EC         |
|              | 0067725030             |     |            |
| <b>ER 32</b> | ER32-DNE-MS42A-062-I-A | 1:1 | IC 100 bar |
|              | 0067725030             |     |            |



**Portautensile rotante di foratura/fresatura (12000 RPM)**

- |                 |                        |     |            |
|-----------------|------------------------|-----|------------|
| <b>ER-25 QF</b> | QF25-DNI-MS42A-070-E-A | 1:1 | EC         |
|                 | 0067725000             |     |            |
| <b>ER-25 QF</b> | QF25-DNI-MS42A-070-I-A | 1:1 | IC 100 bar |
|                 | 0067725000             |     |            |

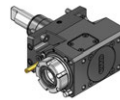

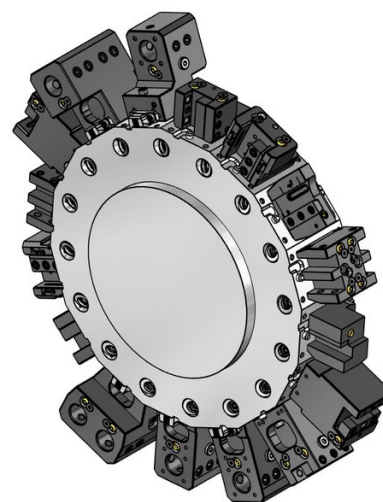
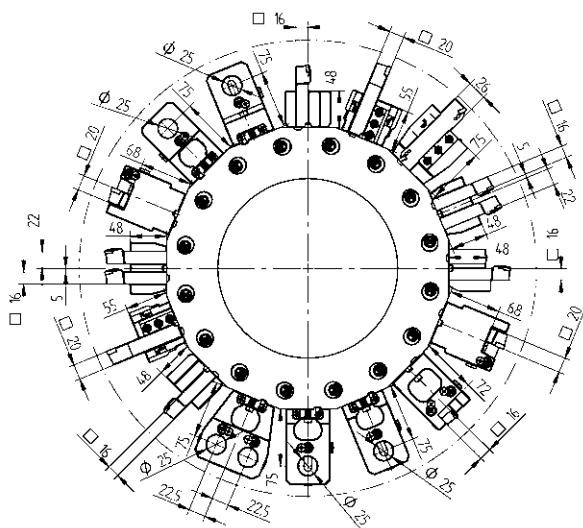

**Portautensile rotante di foratura/fresatura (12000 RPM)**

- |              |                        |     |            |
|--------------|------------------------|-----|------------|
| <b>ER 32</b> | ER32-DNI-MS42A-070-E-A | 1:1 | EC         |
|              | 0067725030             |     |            |
| <b>ER 32</b> | ER32-DNI-MS42A-070-I-A | 1:1 | IC 100 bar |
|              | 0067725030             |     |            |





Portautensili statici - Programma standard

- 

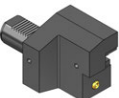
**Portautensile a stelo quadro assiale, destro, forma C1**  
16(12) 48-C1-25x16
- 

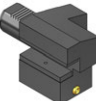
**Portautensile a stelo quadro assiale, sinistro, forma C2**  
16(12) 48-C2-25x16
- 

**Portautensile a stelo quadro assiale, destro invertito, forma C3**  
16(12) 48-C3-25x16
- 

**Portautensile a stelo quadro assiale, sinistro invertito Forma C4**  
16(12) 48-C4-25x16
- 

**Portautensile - doppia dentatura VDI**  
16 48-88237 R2Z415W
- 

**Portautensile per lavorazione su mandrino e contromandrino**  
16 48-71572 R2Z810W
- 

**Portautensile per esterni**  
16 48-74693

Portautensili statici - Programma standard

- 

**Portautensile combinato, universale**  
Ø 25 48-74687  
241125016 ER25
- 

**Portautensile combinato, universale, Trifix®**  
Ø 25 48-98234  
241125016 ER25
- 

**Portautensile combinato arretrato, sinistro**  
Ø 25 48-74689  
241125016 ER25
- 

**Portautensile combinato arretrato, sinistro, Trifix®**  
Ø 25 48-98235  
241125016 ER25
- 

**Portautensile combinato arretrato, destro**  
Ø 25 48-74688  
241125016 ER25
- 

**Portautensile combinato arretrato, destro, Trifix®**  
Ø 25 48-98236  
241125016 ER25

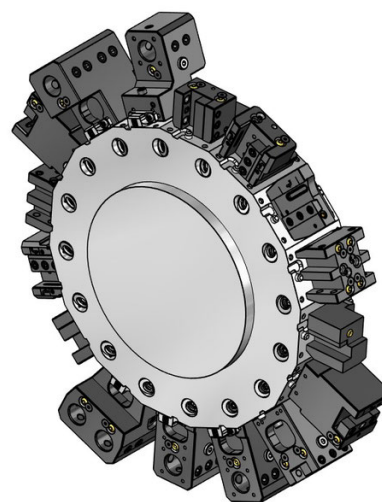
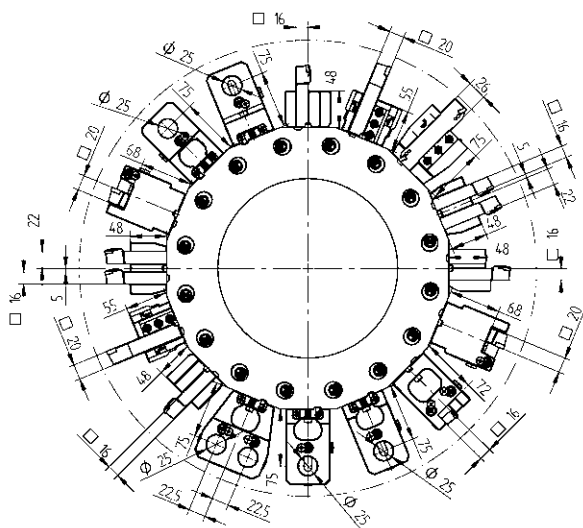

Portautensili statici - Programma standard



Ø 25

**Portautensile combinato per lavorazione su mandrino e contromandrino**

48-74690



Ø 25

**Portautensile combinato per lavorazione su mandrino e contromandrino, Trifix®**

48-98238

Portautensili statici - Estensione del programma



20

**Portautensile, HP-IC - doppia dentatura VDI**

48-106423-HP

IC 80 bar



20

**Portautensile per lavorazione su mandrino e contromandrino, HP-IC**

48-111171-HP

IC 80 bar

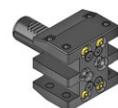

16(5/8")

**Portautensile per lavorazione su mandrino e contromandrino, doppio, asse Y**

48-77394

442770W



20

**Portautensile per esterni, HP-IC - doppia dentatura VDI**

48-107434-HP

IC 80 bar

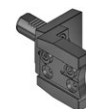

SH 26

**Portautensile da taglio, con regolazione - doppia dentatura VDI**

48-98981

R2Z452W



SH 26

**Portautensile da taglio, con regolazione, HP-IC - doppia dentatura VDI**

48-102647R

IC 80 bar

48-102647L

IC 80 bar

48-106937R

IC 80 bar

343-810100R80

48-106937L

IC 80 bar

343-810100L80

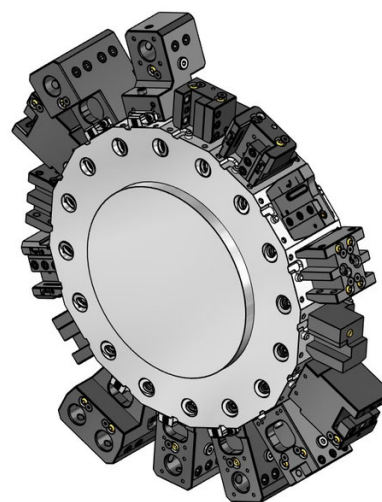
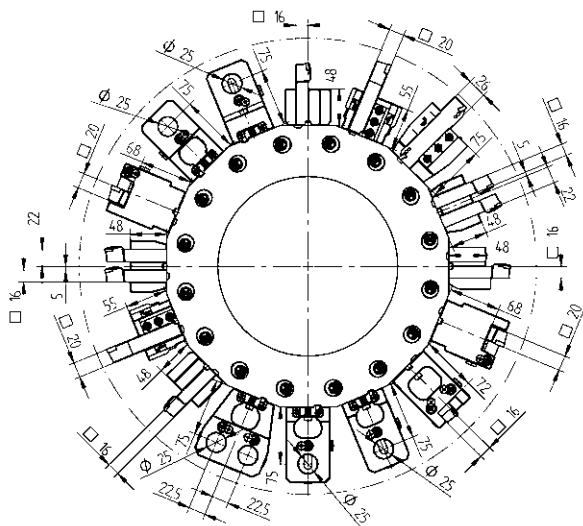

Portautensili statici - Estensione del programma



Ø 25

**Portautensile combinato doppio per lavorazione su mandrino e contromandrino**

48-119657



Ø 25

**Portautensile combinato doppio per lavorazione su mandrino e contromandrino, Trifix®**

48-109204

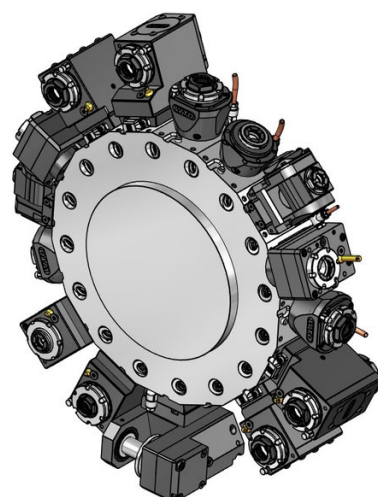
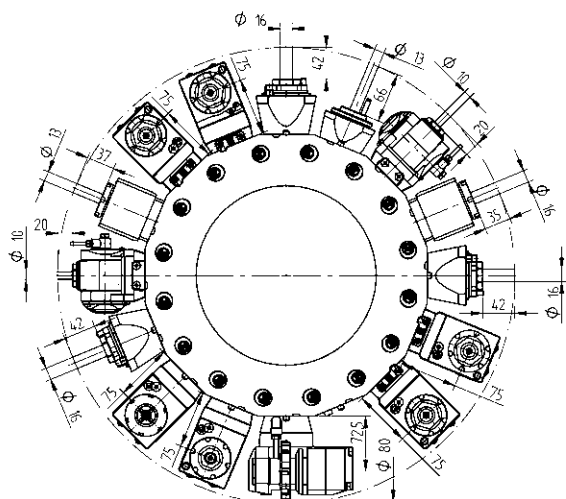

Portautensili Rotanti - QuickFlex®



**Portautensile rotante di foratura/fresatura**

- ER-25 QF 420125010-25 R2Z471W 1:1 EC  
0067725010
- ER-25 QF 420125011-25 1:1 IC 80 bar  
0067725010



**Portautensile rotante radiale, Trifix®**

- ER-25 QF 420525010-25L 1:1 EC  
0067725010
- ER-25 QF 420525011-25L 1:1 IC 80 bar  
0067725010



**Portautensile rotante radiale, Trifix®**

- ER-25 QF 420525010-25R 1:1 EC  
0067725010
- ER-25 QF 420525011-25R 1:1 IC 80 bar  
0067725010



**Portautensile rotante inclinato arretrato di foratura/fresatura, Trifix®**

- ER-25 QF 420525027-25L 1:1 EC  
0067725010
- ER-25 QF 420525028-25L 1:1 IC 80 bar  
0067725010

Portautensili Rotanti - QuickFlex®



**Portautensile rotante inclinato arretrato di foratura/fresatura, Trifix®**

- ER-25 QF 420525027-25R 1:1 EC  
0067725010
- ER-25 QF 420525028-25R 1:1 IC 80 bar  
0067725010



**Portautensile rotante radiale, per lavorazione su mandrino e contromandrino**

- ER-25 QF 420525012-25 1:1 EC  
0067725010

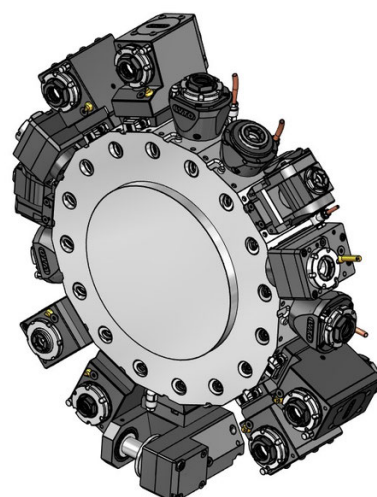
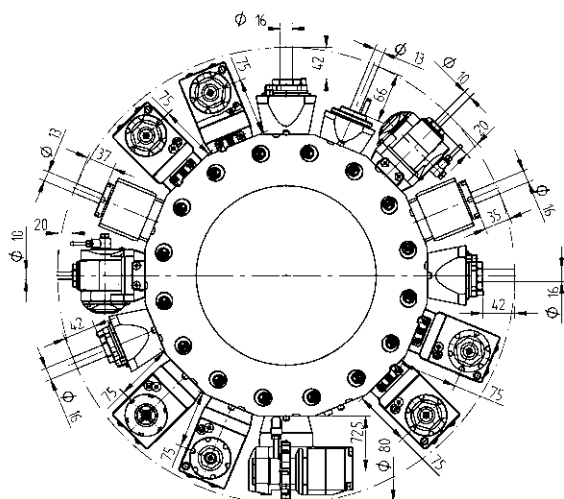

Portautensili Rotanti - Estensione del programma



**Portautensile rotante di foratura/fresatura, corto**

<b>ER 20</b>	410113004-25 R2Z490	1:1	EC
	00675000700		



**Portautensile rotante di fresatura con attacco combinato DIN 6358**

<b>Ø 16</b>	410216003-25	1:1	EC
	00675000854		



**Portautensile rotante di foratura/fresatura, disassato**

<b>ER 25</b>	410116017-25	1:1	EC
	00675000801		
<b>ER 20</b>	410113003-25	1:2	EC
	00675000887		
<b>ER 16</b>	410410000-25	1:3	EC
	00675000636		
<b>ER 25</b>	410116013-25	2:1	EC
	00675000801		

Portautensili Rotanti - Estensione del programma



**Portautensile rotante di foratura/fresatura**

<b>ER-20 QF</b>	420520019-25	1:2	EC
	0067720011		
<b>ER-20 QF</b>	420520020-25	1:2	IC 80 bar
	0067720011		
<b>ER 16</b>	410810012-25	1:3	EC
	00675000841		
<b>ER 16</b>	410810013-25	1:3	IC 80 bar
	00675000841		
<b>ER-25 QF</b>	420525032-25	2:1	EC
	0067725010		
<b>ER-25 QF</b>	420525033-25	2:1	IC 80 bar
	0067725010		



**Portautensile rotante radiale portafrese combinato DIN6358**

<b>Ø 16</b>	410616002-25	1:1	EC
	00675000854		
<b>Ø 22</b>	410622005-25	2:1	EC
	00675000483		
<b>Ø 27</b>	410627002-25	2:1	EC
	00675000245		



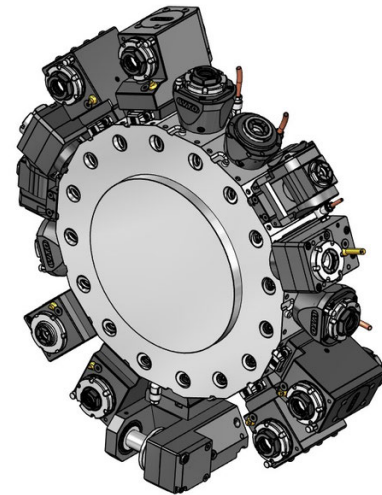
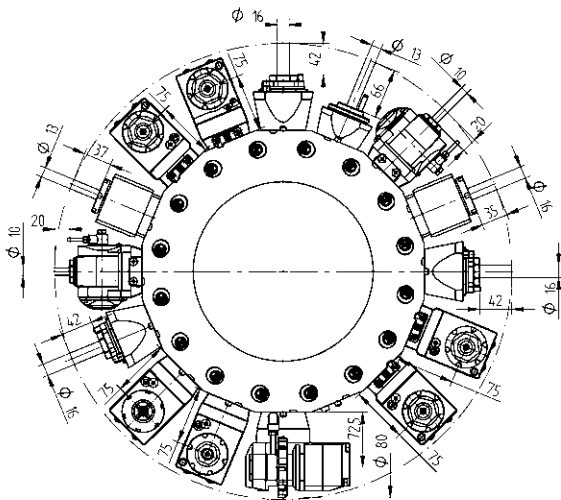

Portautensili Rotanti - Estensione del programma

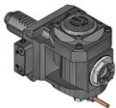

**Portautensile rotante orientabile di foratura/fresatura**

<b>ER 16</b>	411010003-25 00675000902	1:1	EC
<b>ER 16</b>	411010010-25 00675000902	1:1	IC 80 bar
<b>ER 11</b>	411007006-25 00675000914	1:2	EC
<b>ER 11</b>	411007007-25 00675000914	1:2	IC 80 bar



**Portautensile rotante disassato per frese a disco**

<b>Tipo 14-2</b>	411500002-25 00675000460	2,727:1EC
	160016142 Ø 16	
	160022142 Ø 22	
	160027142 Ø 27	
	160015142 Ø 5/8"	
	160019142 Ø 3/4"	
	160023142 Ø 7/8"	
	160025142 Ø 1"	

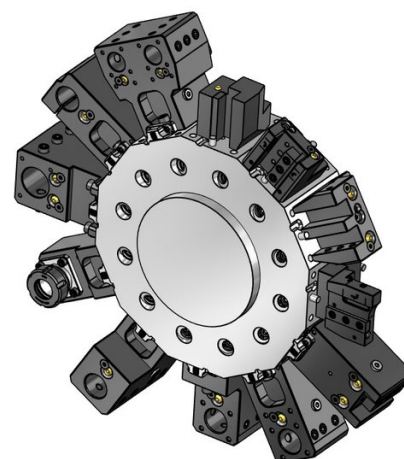
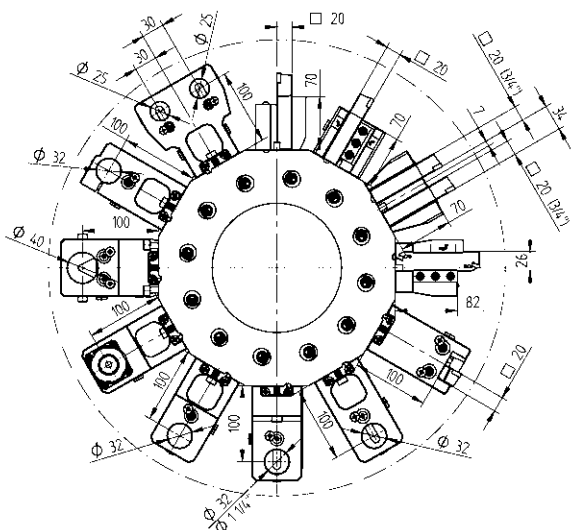

Portautensili statici - Programma standard



**Portautensile a stelo quadro assiale, destro, forma C1**  
20(16) 48-C1-30x20



**Portautensile a stelo quadro assiale, sinistro, forma C2**  
20(16) 48-C2-30x20

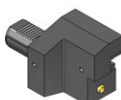

**Portautensile a stelo quadro assiale, destro invertito, forma C3**  
20(16) 48-C3-30x20

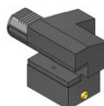

**Portautensile a stelo quadro assiale, sinistro invertito, forma C4**  
20(16) 48-C4-30x20

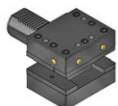

**Portautensile universale, forma D1**  
20(16) 48-D1-30x20



**Portautensile universale, inverso, forma D2**  
20(16) 48-D2-30x20



**Portautensile sinistro**  
20 48-71932 R4Z410W

Portautensili statici - Programma standard



**Portautensile destro**  
20 48-72047 R4Z230W



**Portautensile per lavorazione su mandrino e contromandrino**  
20 48-71216 R6Z410W



**Portautensile per esterni**  
20 48-105756



**Portautensile Trifix®**  
20 48-109793



**Portautensile combinato, universale, LF=100**  
Ø 32 48-71434  
241132016 ER25  
241132020 ER32



**Portautensile combinato, universale, Trifix®, LF=100**  
Ø 32 48-96995  
241132016 ER25  
241132020 ER32

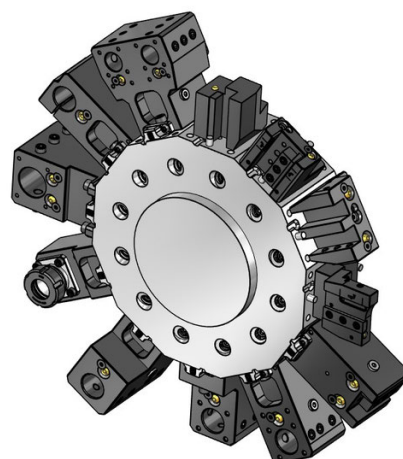
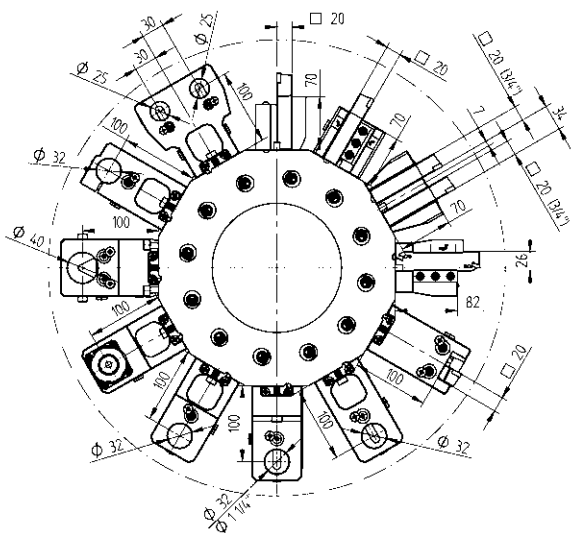

Portautensili statici - Programma standard

- 

**Portautensile combinato arretrato, sinistro, LF=100**  
 Ø 32 48-71438  
 241132016 ER25  
 241132020 ER32
- 

**Portautensile combinato arretrato, sinistro, Trifix®, LF=100**  
 Ø 32 48-97531  
 241132016 ER25  
 241132020 ER32
- 

**Portautensile combinato arretrato, destro, LF=100**  
 Ø 32 48-71436  
 241132016 ER25  
 241132020 ER32
- 

**Portautensile combinato arretrato, destro, Trifix®, LF=100**  
 Ø 32 48-97553  
 241132016 ER25  
 241132020 ER32
- 

**Portautensile combinato per lavorazione su mandrino e contromandrino, LF=100**  
 Ø 32 48-88781

Portautensili statici - Programma standard

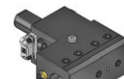
- 

**Portautensile combinato per lavorazione su mandrino e contromandrino, Trifix®, LF=100**  
 Ø 32 48-97496
- 

**Portautensile di foratura, LF=100**  
 ER 32 48-82824 IC 80 bar  
 107532000
- 

**Portautensile di foratura, Trifix®, LF=100**  
 ER 32 48-100198 IC 80 bar  
 107532000
- 

**Portautensile di foratura per lavorazione su mandrino e contromandrino, LF=100**  
 ER 32 48-82847 IC 80 bar  
 107532000
- 

**Portautensile di foratura per lavorazione su mandrino e contromandrino, Trifix®, LF=100**  
 ER 32 48-100199 IC 80 bar  
 107532000
- 

**Tappo di protezione in acciaio, forma Z2**  
 Acciaio 48-Z2-30-S

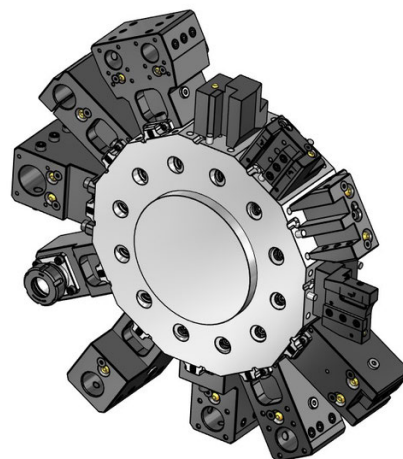
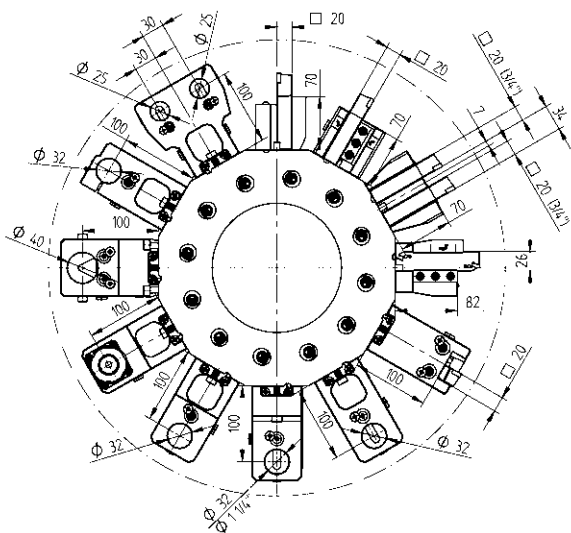

Portautensili statici - Estensione del programma

Portautensili statici - Estensione del programma



**Portautensile, HP-IC - doppia dentatura VDI**

20 48-105977-HP IC 80 bar



**Portautensile per lavorazione su mandrino e contromandrino, HP-IC**

20 48-71216-HP IC 80 bar



**Portautensile doppio, asse Y - doppia dentatura VDI**

20 (3/4") 48-84593



**Portautensile per lavorazione su mandrino e contromandrino, doppio, asse Y**

20 (3/4") 48-77395  
442750W



**Portautensile da taglio, con regolazione - doppia dentatura VDI**

SH 26 48-98991  
R4Z451W  
SH 32 48-99017  
R9Z450



**Portautensile da taglio, con regolazione, HP-IC - doppia dentatura VDI**

SH 26 48-102630R IC 80 bar  
343-810100R42  
SH 26 48-102630L IC 80 bar  
343-810100L42  
SH 32 48-102632R IC 80 bar  
SH 32 48-102632L IC 80 bar



**Portautensile combinato, universale, Trifix®, LF=100 - BMT**

Ø 40 48-99669  
241140020 ER32  
241140026 ER40



**Portautensile combinato per lavorazione su mandrino e contromandrino - lungo**

Ø 25 48-113666



**Portabareno con serraggio a morsetto, LF=100**

Ø 32 48-87088



**Portabareno con serraggio a morsetto, Trifix®, LF=100**

Ø 32 48-97588



**Portabareno con serraggio a morsetto, Trifix®, LF=100 - BMT**

Ø 40 48-96994



**Portautensile combinato doppio, asse Y, LF=100**

Ø 25 48-79026  
241125016 ER25



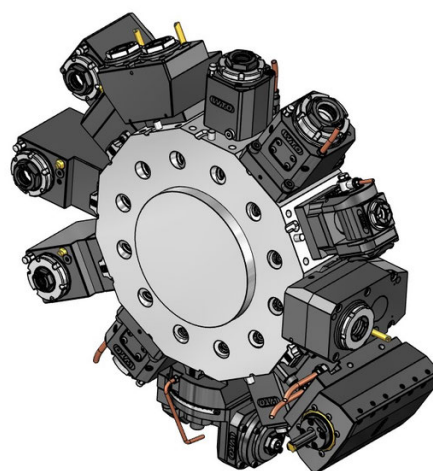
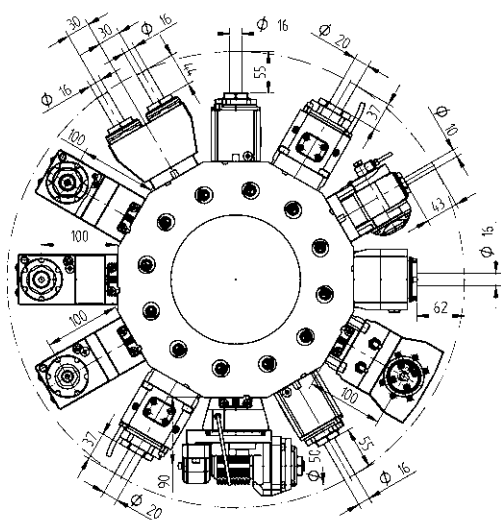

Portautensili Rotanti - QuickFlex®



**Portautensile rotante di foratura/fresatura assiale (6000 RPM)**

**ER-25 QF** 420125010-30L 1:1 EC  
440441W  
0067725010

**ER-25 QF** 420125019-30L 1:1 IC 80 bar  
0067725010



**Portautensile rotante di foratura/fresatura (12000 RPM)**

**ER-25 QF** 420125014-30L 1:1 EC  
0067725010

**ER-25 QF** 420125015-30L 1:1 IC 80 bar  
0067725010



**Portautensile rotante radiale, Trifix®, (6000 RPM)**

**ER-25 QF** 420525055-30L 1:1 EC  
0067725010

**ER-25 QF** 420525056-30L 1:1 IC 80 bar  
0067725010



**Portautensile rotante radiale, Trifix®, (12000 RPM)**

**ER-25 QF** 420525057-30L 1:1 EC  
0067725010

**ER-25 QF** 420525058-30L 1:1 IC 80 bar  
0067725010

Portautensili Rotanti - QuickFlex®



**Portautensile rotante radiale, Trifix®, (6000 RPM)**

**ER-25 QF** 420525055-30R 1:1 EC  
0067725010

**ER-25 QF** 420525056-30R 1:1 IC 80 bar  
0067725010



**Portautensile rotante radiale, Trifix®, (12000 RPM)**

**ER-25 QF** 420525057-30R 1:1 EC  
0067725010

**ER-25 QF** 420525058-30R 1:1 IC 80 bar  
0067725010



**Portautensile rotante inclinato arretrato di foratura/fresatura, Trifix®, (6000 RPM)**

**ER-25 QF** 420525089-30L 1:1 EC  
0067725010

**ER-25 QF** 420525090-30L 1:1 IC 80 bar  
0067725010



**Portautensile rotante inclinato arretrato di foratura/fresatura, Trifix®, (12000 RPM)**

**ER-25 QF** 420525060-30L 1:1 EC  
0067725010

**ER-25 QF** 420525061-30L 1:1 IC 80 bar  
0067725010

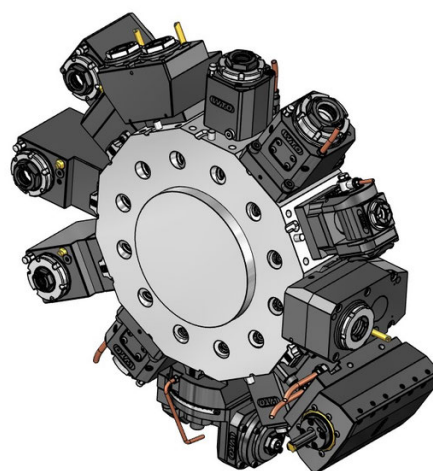
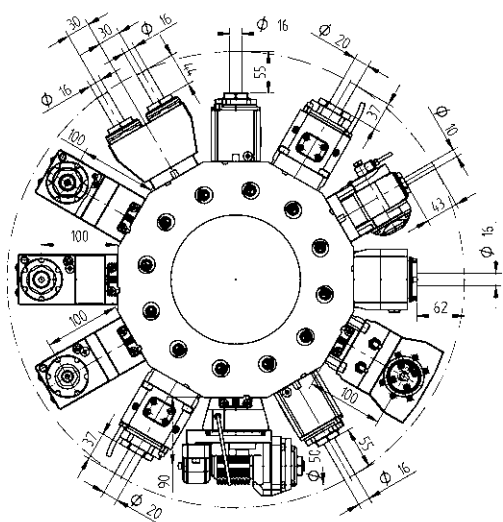

Portautensili Rotanti - QuickFlex®

Portautensili Rotanti - Estensione del programma



**Portautensile rotante inclinato arretrato di foratura/fresatura, Trifix®, (6000 RPM)**

<b>ER-25 QF</b>	420525089-30R 0067725010	1:1	EC
<b>ER-25 QF</b>	420525090-30R 0067725010	1:1	IC 80 bar



**Portautensile rotante inclinato arretrato di foratura/fresatura, Trifix®, (12000 RPM)**

<b>ER-25 QF</b>	420525060-30R 0067725010	1:1	EC
<b>ER-25 QF</b>	420525061-30R 0067725010	1:1	IC 80 bar



**Portautensile rotante radiale, per lavorazione su mandrino e contromandrino, Trifix®, (6000 RPM)**

<b>ER-25 QF</b>	420525086-30 0067725010	1:1	EC
-----------------	----------------------------	-----	----



**Portautensile rotante radiale, per lavorazione su mandrino e contromandrino, Trifix®, (12000 RPM)**

<b>ER-25 QF</b>	420525095-30 0067725010	1:1	EC
-----------------	----------------------------	-----	----



**Portautensile rotante di foratura/fresatura - BMT**

<b>ER-32 QF</b>	420132010-30 0067732000	1:1	EC
<b>ER-32 QF</b>	420132011-30 0067732000	1:1	IC 80 bar



**Portautensile rotante di fresatura**

<b>Ø 16</b>	410216014-30 00675000854	1:1	EC
-------------	-----------------------------	-----	----

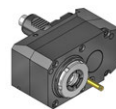

**Portautensile rotante di foratura/fresatura, disassato**

<b>ER 25</b>	410116058-30 00675000801	1:1	EC
<b>ER 25</b>	410116057-30 00675000801	1:1	IC 80 bar
<b>ER 20</b>	410113010-30 00675000591	1:2	EC
<b>ER 20</b>	410113009-30 00675000591	1:2	IC 80 bar
<b>ER 25</b>	410116059-30 00675000801	2:1	EC
<b>ER 25</b>	410116060-30 00675000801	2:1	IC 80 bar
<b>ER 32</b>	410120027-30 00675000592	2:1	EC
<b>ER 32</b>	410120032-30 00675000592	2:1	IC 80 bar

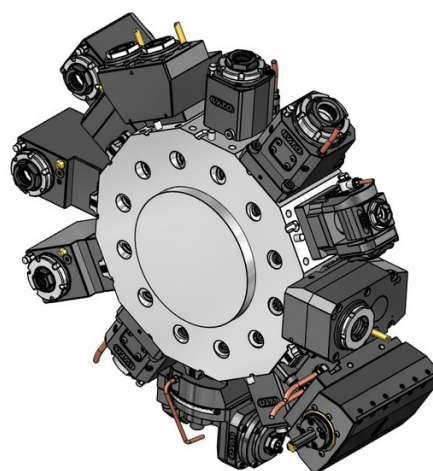
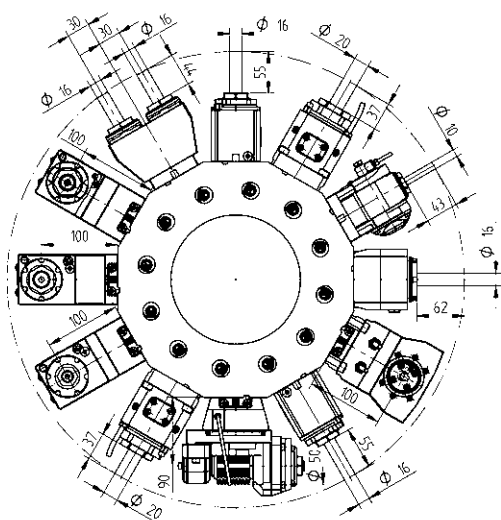

Portautensili Rotanti - Estensione del programma

Portautensili Rotanti - Estensione del programma



**Portautensile rotante di foratura/fresatura, disassato - doppia dentatura VDI**

- |              |              |     |           |
|--------------|--------------|-----|-----------|
| <b>ER 16</b> | 410410002-30 | 1:3 | EC        |
|              | 00675000937  |     |           |
| <b>ER 16</b> | 410410001-30 | 1:3 | IC 80 bar |
|              | 00675000937  |     |           |



**Portautensile rotante radiale arretrato di foratura/fresatura**

- |              |              |     |           |
|--------------|--------------|-----|-----------|
| <b>ER 32</b> | 410520013-30 | 2:1 | EC        |
|              | 00675000592  |     |           |
| <b>ER 32</b> | 410520014-30 | 2:1 | IC 80 bar |
|              | 00675000592  |     |           |



**Portautensile rotante di foratura/fresatura**

- |                 |              |     |           |
|-----------------|--------------|-----|-----------|
| <b>ER-20 QF</b> | 420520013-30 | 1:2 | EC        |
|                 | 0067720011   |     |           |
| <b>ER-20 QF</b> | 420520014-30 | 1:2 | IC 80 bar |
|                 | 0067720011   |     |           |
| <b>ER 16</b>    | 410810012-30 | 1:3 | EC        |
|                 | 00675000841  |     |           |
| <b>ER 16</b>    | 410810013-30 | 1:3 | IC 80 bar |
|                 | 00675000841  |     |           |
| <b>ER-25 QF</b> | 420525096-30 | 2:1 | EC        |
|                 | 0067725010   |     |           |
| <b>ER-25 QF</b> | 420525097-30 | 2:1 | IC 80 bar |
|                 | 0067725010   |     |           |

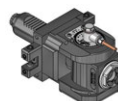

**Portautensile rotante orientabile di foratura/fresatura**

- |              |              |     |           |
|--------------|--------------|-----|-----------|
| <b>ER 16</b> | 411010015-30 | 1:1 | EC        |
|              | 00675000902  |     |           |
| <b>ER 16</b> | 411010016-30 | 1:1 | IC 80 bar |
|              | 00675000902  |     |           |
| <b>ER 11</b> | 411007018-30 | 1:2 | EC        |
|              | 00675000914  |     |           |
| <b>ER 11</b> | 411007019-30 | 1:2 | IC 80 bar |
|              | 00675000914  |     |           |



**Portautensile rotante radiale, Trifix®**

- |                 |               |     |           |
|-----------------|---------------|-----|-----------|
| <b>ER-20 QF</b> | 420520015-30L | 1:2 | EC        |
|                 | 0067720011    |     |           |
| <b>ER-20 QF</b> | 420520016-30L | 1:2 | IC 80 bar |
|                 | 0067720011    |     |           |

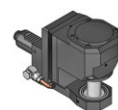

**Portautensile rotante portafrese a disco**

- |                  |                  |           |
|------------------|------------------|-----------|
| <b>Tipo 14-2</b> | 410900008-30     | 2,615:1EC |
|                  | 00675000460      |           |
|                  | 160016142 Ø 16   |           |
|                  | 160022142 Ø 22   |           |
|                  | 160027142 Ø 27   |           |
|                  | 160015142 Ø 5/8" |           |
|                  | 160019142 Ø 3/4" |           |
|                  | 160023142 Ø 7/8" |           |
|                  | 160025142 Ø 1"   |           |



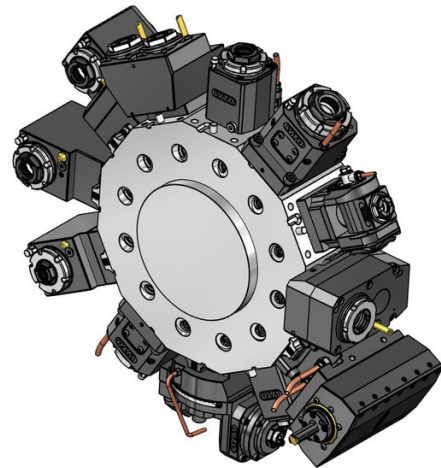
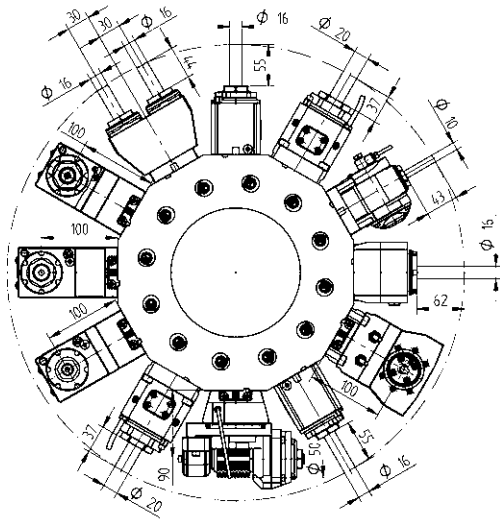

Portautensili Rotanti - Estensione del programma

Portautensili Rotanti - Estensione del programma



**Unità porta creatore, Trifix®**

- |                  |                  |     |    |
|------------------|------------------|-----|----|
| <b>Tipo 15-2</b> | 410900025-30     | 1:1 | EC |
|                  | 00675001015      |     |    |
|                  | 160008152 Ø 8    |     |    |
|                  | 160010152 Ø 10   |     |    |
|                  | 160013152 Ø 13   |     |    |
|                  | 160016152 Ø 16   |     |    |
|                  | 160022152 Ø 22   |     |    |
|                  | 160015152 Ø 5/8" |     |    |
|                  | 160019152 Ø 3/4" |     |    |
|                  | 110587           |     |    |

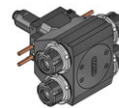

**Portautensile rotante di foratura/fresatura a 2 uscite, per lavorazione su mandrino e contromandrino, asse Y**

- |              |              |     |    |
|--------------|--------------|-----|----|
| <b>ER 25</b> | 413502009-30 | 1:1 | EC |
|              | 00675000915  |     |    |

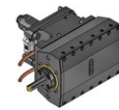

**Unità di brocciatura per interni ed esterni, Trifix - BMT**

- |                |               |     |    |
|----------------|---------------|-----|----|
| <b>Tipo 32</b> | 414532001-30L | 1:1 | EC |
|----------------|---------------|-----|----|



**Portautensile rotante di foratura/fresatura - doppio, asse Y**

- |              |              |       |           |
|--------------|--------------|-------|-----------|
| <b>ER 25</b> | 413002008-30 | 1:1,5 | EC        |
|              | 00675000930  |       |           |
| <b>ER 25</b> | 413002009-30 | 1:1,5 | IC 80 bar |
|              | 00675000930  |       |           |

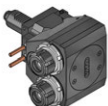

**Portautensile rotante di foratura/fresatura a 2 uscite, asse Y**

- |              |              |     |           |
|--------------|--------------|-----|-----------|
| <b>ER 25</b> | 413502000-30 | 1:1 | EC        |
|              | 00675000915  |     |           |
| <b>ER 25</b> | 413502004-30 | 1:1 | IC 80 bar |
|              | 00675000915  |     |           |

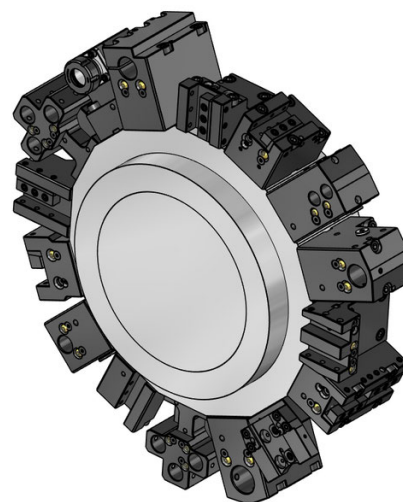
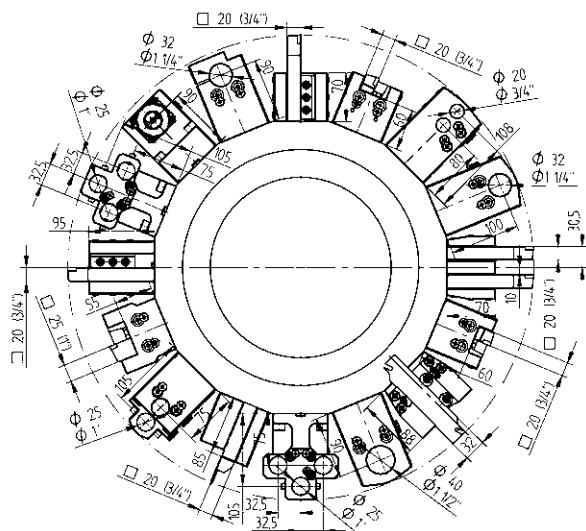

Portautensili statici - Programma standard



**Portautensile corto**

- 20 48-T00224  
T00224
- 25 48-T00267  
T00267



**Portautensile corto, HP-IC**

- 20 48-T00224-HP IC 80 bar  
T00224
- 25 48-T00267-HP IC 80 bar  
T00267



**Portautensile lungo**

- 20 48-T00225  
T00225



**Portautensile per lavorazione su mandrino e contromandrino, corto**

- 20 48-T00228  
T00228
- 25 48-86523



**Portautensile per lavorazione su mandrino e contromandrino, corto, HP-IC**

- 20 48-T00228-HP IC 80 bar  
T00228
- 25 48-86523-HP IC 80 bar

Portautensili statici - Programma standard



**Portautensile per lavorazione su mandrino e contromandrino, lungo**

- 20 48-T00226  
T00226



**Portautensile per esterni**

- 25 48-T03024  
T03024



**Portautensile per esterni, HP-IC**

- 20 48-T03017-HP IC 80 bar  
T03017



**Portautensile da taglio, destro**

- 20 48-T00251  
T00251
- 25 48-T00268  
T00268, T00356



**Portabareno**

- Ø 32 48-T10115  
T10115



**Portautensile combinato**

- Ø 32 48-T13132 IC 80 bar  
T13132
- Ø 40 48-77999 IC 80 bar

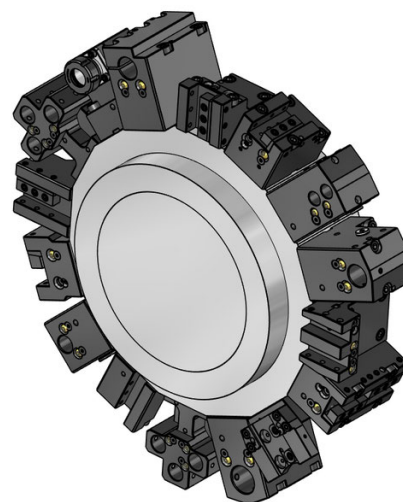
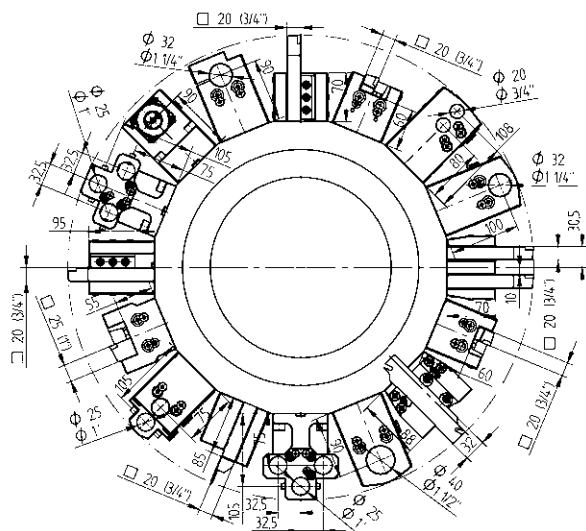

Portautensili statici - Programma standard

Portautensili statici - Estensione del programma



Ø 25

**Portabareno per lavorazione su mandrino e contromandrino**

48-T10117  
T10117



20 (3/4")

**Portautensile doppio, asse Y**

48-77726



20 (3/4")

**Portautensile per lavorazione su mandrino e contromandrino, doppio, asse Y**

48-77727



20

**Portautensile per esterni doppio**

48-79608



SH 32

**Portautensile da taglio, con regolazione**

48-98891



SH 32

**Portautensile da taglio, con regolazione, HP-IC**

48-102261R

IC 80 bar

SH 32

48-102261L

IC 80 bar



Ø 32

**Portabareno con serraggio a morsetto**

Ø 40

48-82057

48-82058



Ø 20

**Portabareno doppio per lavorazione su mandrino e contromandrino**

48-75406

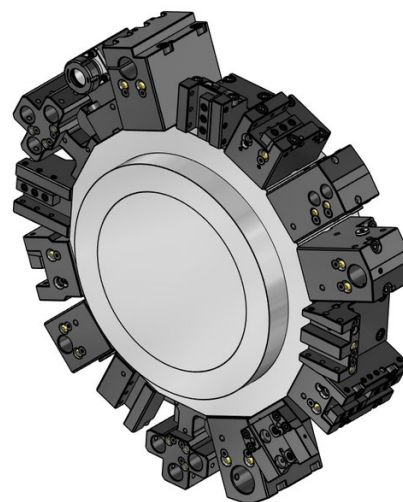
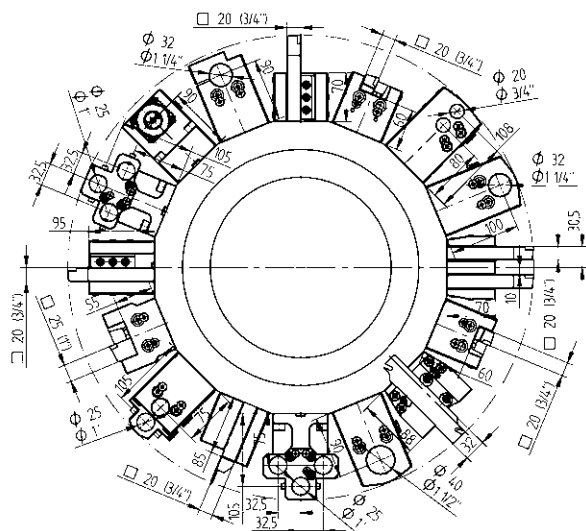

Portautensili statici - Estensione del programma

Portautensili statici - Estensione del programma



Ø 20 48-75404



48-80506



Ø 25 48-85908 IC 80 bar



ER 25 48-107230 IC 80 bar

107525000

ER 32 48-81031 IC 80 bar

107532000



ER 25 48-107227 IC 80 bar

107525000

ER 32 48-80509 IC 80 bar

107532000



VDI 30 48-77732



VDI 30 48-78687

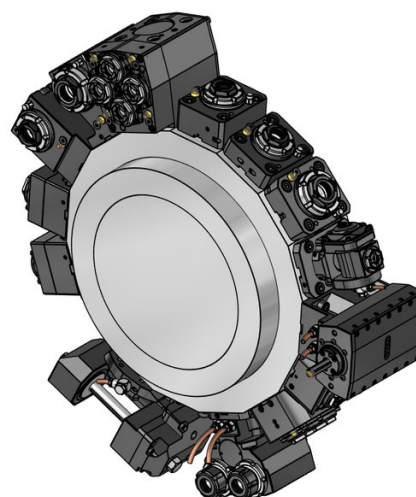
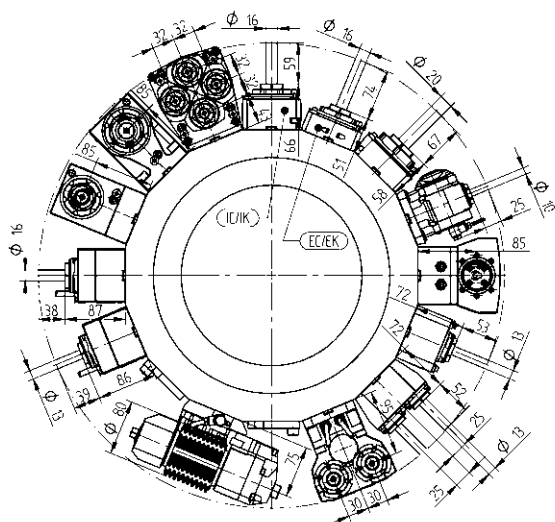

Portautensili Rotanti - QuickFlex®



**Portautensile rotante di foratura/fresatura (12000 RPM)**

- ER-25 QF** 420125012-40 T32433 1:1 EC  
0067725000
- ER-25 QF** 420125013-40 1:1 IC 80 bar  
0067725000
- ER-32 QF** QF32-DNE-MS40A-050-E-HS-A 1:1 EC  
0067732000
- ER-32 QF** QF32-DNE-MS40A-067-I-HS-A 1:1 IC 100 bar  
0067732000



**Portautensile rotante di foratura/fresatura (12000 RPM) - QF smart (UE, US, CA, JP)**

- ER-32 QF** QF32-DNE-MS40A-067-I-HS-SB-A 1:1 IC 100 bar  
0067732000  
LI-F12-01



**Portautensile rotante di foratura/fresatura (6000 RPM, Heavy Duty)**

- ER-25 QF** 420125010-40 T32274, T32450 1:1 EC  
0067725000
- ER-25 QF** 420125011-40 T32287 1:1 IC 80 bar  
0067725000
- ER-32 QF** 420132010-40 T32475, T32484 1:1 EC  
0067732000
- ER-32 QF** 420132011-40 1:1 IC 80 bar  
0067732000

Portautensili Rotanti - QuickFlex®



**Portautensile rotante di foratura/fresatura (12000 RPM)**

- ER-25 QF** 420525013-40 T32434 1:1 EC  
0067725000
- ER-25 QF** 420525014-40 T32436 1:1 IC 80 bar  
0067725000
- ER-32 QF** QF32-DNI-MS40A-085-E-HS-A 1:1 EC  
0067732000
- ER-32 QF** QF32-DNI-MS40A-085-I-HS-A 1:1 IC 100 bar  
0067732000



**Portautensile rotante di foratura/fresatura (12000 RPM) - QF smart (UE, US, CA, JP)**

- ER-32 QF** QF32-DNI-MS40A-085-I-HS-SB-A 1:1 IC 100 bar  
0067732000  
LI-F12-01



**Portautensile rotante di foratura/fresatura (6000 RPM, Heavy Duty)**

- ER-25 QF** 420525010-40 T32275, T32297 1:1 EC  
0067725000
- ER-25 QF** 420525011-40 T32288, T32435 1:1 IC 80 bar  
0067725000
- ER-32 QF** 420532010-40 T32476, T32485 1:1 EC  
0067732000

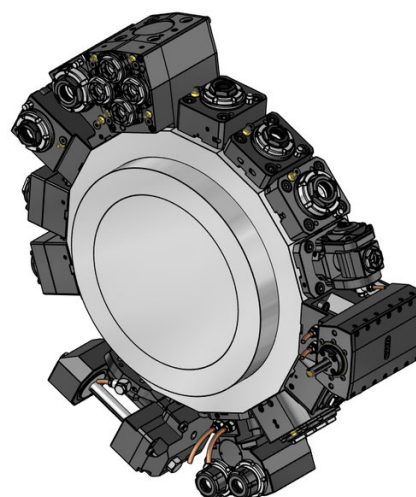
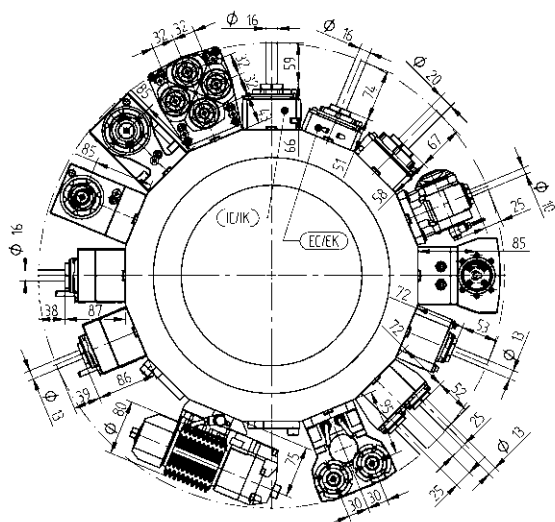

Portautensili Rotanti - QuickFlex®



**Portautensile rotante di foratura/fresatura, per lavorazione su mandrino e contromandrino (12000 RPM)**

- |                 |              |     |    |
|-----------------|--------------|-----|----|
| <b>ER-25 QF</b> | 420525049-40 | 1:1 | EC |
|                 | 0067725000   |     |    |
| <b>ER-32 QF</b> | 420532148-40 | 1:1 | EC |
|                 | 0067732000   |     |    |



**Portautensile rotante di foratura/fresatura, per lavorazione su mandrino e contromandrino (6000 RPM, Heavy Duty)**

- |                 |                                |     |    |
|-----------------|--------------------------------|-----|----|
| <b>ER-25 QF</b> | 420525012-40<br>T32276, T32437 | 1:1 | EC |
|                 | 0067725000                     |     |    |
| <b>ER-32 QF</b> | 420532012-40                   | 1:1 | EC |
|                 | 0067732000                     |     |    |

Portautensili Rotanti - Estensione del programma

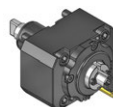

**Portautensile rotante di fresatura con attacco combinato DIN 6358**

- |             |                |     |    |
|-------------|----------------|-----|----|
| <b>Ø 16</b> | 410216010-40   | 1:1 | EC |
|             | 00675000854    |     |    |
| <b>Ø 22</b> | 410222016-40   | 1:1 | EC |
|             | T32280, T32486 |     |    |
|             | 00675000483    |     |    |



**Portautensile rotante di foratura/fresatura, disassato**

- |              |                        |     |           |
|--------------|------------------------|-----|-----------|
| <b>ER 25</b> | 410116050-40<br>T32488 | 1:1 | EC        |
|              | 00675000932            |     |           |
| <b>ER 25</b> | 410116057-40           | 1:1 | IC 80 bar |
|              | 00675000932            |     |           |
| <b>ER 20</b> | 410113060-40           | 1:2 | EC        |
|              | 00675000939            |     |           |
| <b>ER 20</b> | 410113068-40           | 1:2 | IC 80 bar |
|              | 00675000939            |     |           |
| <b>ER 16</b> | 410410003-40           | 1:3 | EC        |
|              | 00675000937            |     |           |
| <b>ER 16</b> | 410410004-40           | 1:3 | IC 80 bar |
|              | 00675000937            |     |           |
| <b>ER 25</b> | 410116051-40           | 2:1 | EC        |
|              | 00675000932            |     |           |
| <b>ER 25</b> | 410116058-40           | 2:1 | IC 80 bar |
|              | 00675000932            |     |           |

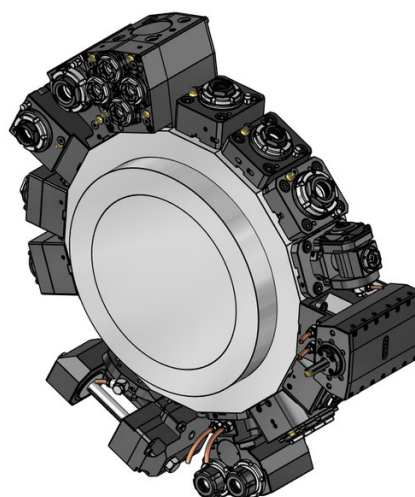
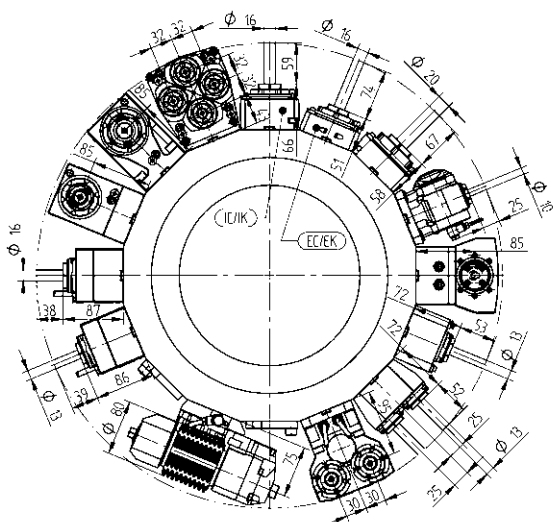

Portautensili Rotanti - Estensione del programma

Portautensili Rotanti - Estensione del programma



**Portautensile rotante di foratura/fresatura, disassato (12000 RPM)**

<b>ER 25</b>	410116060-40	1:1	EC
	00675000932		
<b>ER 25</b>	410116059-40	1:1	IC 80 bar
	00675000932		



**Portautensile rotante arretrato di foratura/fresatura**

<b>ER 25</b>	410516153-40	1:1	EC
	00675000801		
<b>ER 25</b>	410516154-40	1:1	IC 80 bar
	00675000801		



**Portautensile rotante di foratura/fresatura**

<b>ER-20 QF</b>	420520010-40	1:2	EC
	0067720001		
<b>ER-20 QF</b>	420520011-40	1:2	IC 80 bar
	0067720001		
<b>ER 16</b>	410810012-40	1:3	EC
	0067825001		
<b>ER 16</b>	410810013-40	1:3	IC 80 bar
	0067825001		
<b>ER-32 QF</b>	420532013-40	2:1	EC
	0067732000		
<b>ER-32 QF</b>	QF32-DNI-MS40A-085-I-T-A	2:1	IC 100 bar
	0067732000		



**Portautensile rotante orientabile di foratura/fresatura**

<b>ER 16</b>	411010008-40	1:1	EC
	00675000913		
<b>ER 16</b>	411010009-40	1:1	IC 80 bar
	00675000913		
<b>ER 11</b>	411007001-40	1:2	EC
	00675000914		
<b>ER 11</b>	411007002-40	1:2	IC 80 bar
	00675000914		



**Portautensile rotante con attacco portafrese combinato DIN 6358**

<b>Ø 16</b>	410616013-40	1:1	EC
	00675000854		
<b>Ø 22</b>	410622030-40	1:1	EC
	00675000483		

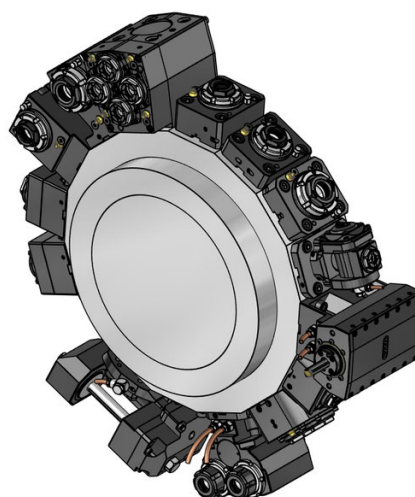
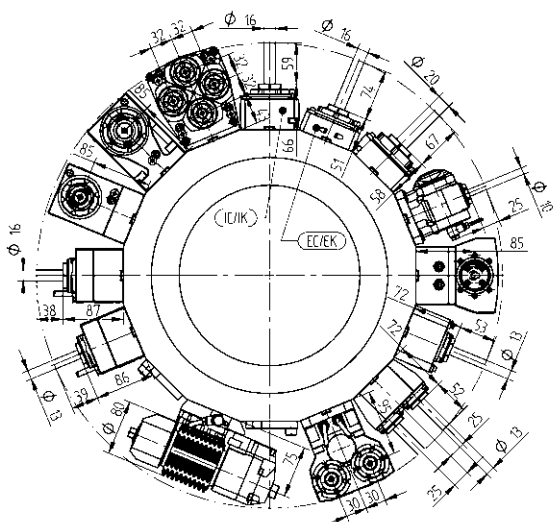

Portautensili Rotanti - Estensione del programma



**Unità porta creatore**

<b>Tipo 16-1</b>	411500017-40	1:1	EC
<b>Tipo 16-1</b>	411500018-40	2:1	EC
	00675000954		
	160016161 Ø 16		
	160022161 Ø 22		
	160027161 Ø 27		
	160015161 Ø 5/8"		
	160019161 Ø 3/4"		
	160025161 Ø 1"		
	160031161 Ø 1 1/4"		
	110587		



**Portautensile rotante di foratura e fresatura, per lavorazione su mandrino e contromandrino**

<b>ER 20</b>	413002015-40	1:1	EC
	00675000947		
<b>ER 20</b>	413002018-40	1:1	IC 80 bar
	00675000947		



**Portautensile rotante di foratura/fresatura - doppio, asse Y**

<b>ER 20</b>	413002014-40	1:1	EC
	00675000947		
<b>ER 20</b>	413002017-40	1:1	IC 80 bar
	00675000947		

Portautensili Rotanti - Estensione del programma

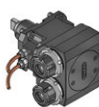

**Portautensile rotante di foratura/fresatura a 2 uscite, asse Y**

<b>ER 25</b>	413502008-40	1:1	EC
	00675000915		
<b>ER 25</b>	413502009-40	1:1	IC 80 bar
	00675000915		



**Portautensile rotante di foratura/fresatura a 2 uscite, per lavorazione su mandrino e contromandrino, asse Y**

<b>ER 25</b>	413502007-40	1:1	EC
	00675000915		



**Portautensile rotante di foratura/fresatura a 4 uscite**

<b>ER 20</b>	413504001-40	1:1	EC
	00675000947		



**Portautensile rotante di foratura/fresatura a 4 uscite, con mandrino e contromandrino**

<b>ER 20</b>	413504000-40	1:1	EC
	00675000947		



**Unità di brocciatura per interni ed esterni**

<b>Tipo 32</b>	414532000-40	1:1	EC
----------------	--------------	-----	----



**Unità di brocciatura per interni ed esterni**

<b>Tipo 52</b>	414552002-40	1:1	EC
----------------	--------------	-----	----



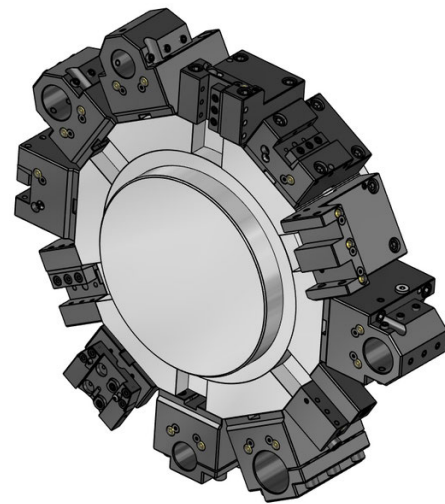
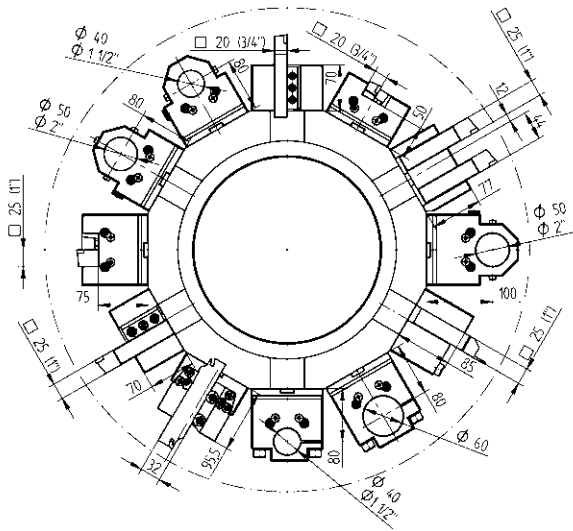

Portautensili statici - Programma standard



- Portautensile**  
 20 48-T00187  
 T00187  
 25 48-T00186  
 T00186



- Portautensile, HP-IC**  
 25 48-T00186-HP IC 80 bar  
 T00186



- Portautensile per esterni**  
 20 48-T03006  
 T03006  
 25 48-T03005  
 T03005



- Portautensile per esterni, HP-IC**  
 25 48-T03005-HP IC 80 bar  
 T03005



- Portautensile da taglio, destro**  
 25 48-T00197  
 T00197

Portautensili statici - Programma standard



- Portabareno, LF=80**  
 Ø 40 48-T10097  
 T10097  
 Ø 50 48-T10098  
 T10098



- Portabareno, LF=100**  
 Ø 40 48-T10181  
 T10181  
 Ø 50 48-T10185  
 T10185



- Portautensile combinato, LF=80**  
 Ø 40 48-T13128 IC 80 bar  
 T13128  
 Ø 50 48-T13139 IC 80 bar  
 T13139



- Portautensile combinato, LF=100**  
 Ø 40 48-110098 IC 80 bar  
 Ø 50 48-110099 IC 80 bar

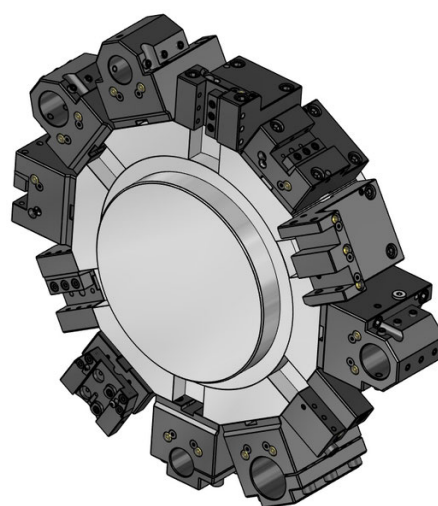
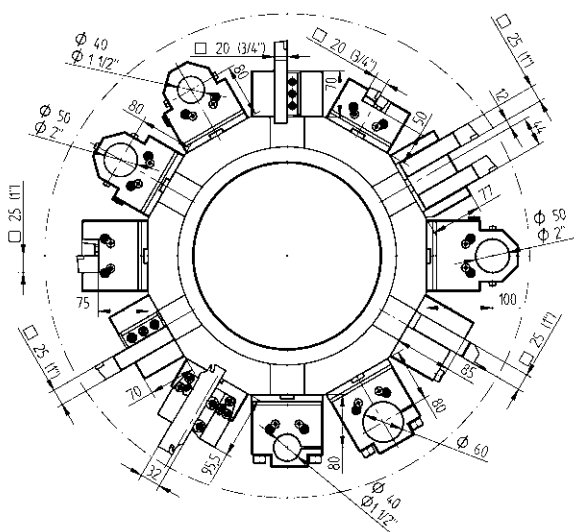

Portautensili statici - Estensione del programma

Portautensili statici - Estensione del programma



**Portautensile destro, lungo, HP-IC**  
**25** 48-T00385-HP IC 80 bar  
 T00385



**Portautensile sinistro, lungo, HP-IC**  
**25** 48-T00387-HP IC 80 bar  
 T00387



**Portautensile corto**  
**25** 48-79591



**Portautensile, prolungato**  
**25** 48-T00236  
 T00236



**Portautensile doppio, asse Y**  
**25(1")** 48-71865  
 T00206, T00210



**Portautensile da taglio, con regolazione**  
**SH 32** 48-98901



**Portautensile da taglio, con regolazione, HP-IC**  
**SH 32** 48-102262R IC 80 bar  
**SH 32** 48-102262L IC 80 bar



**Portautensile da taglio lungo, con regolazione**  
**SH 32** 48-77478



**Portabareno con serraggio a morsetto**  
**Ø 40** 48-T10136  
 T10136  
**Ø 50** 48-T10137  
 T10137  
**Ø 60** 48-70811



**Adattatore VDI, sinistro**  
**VDI 30** 48-77127  
**VDI 40** 48-72984



**Adattatore VDI, destro**  
**VDI 30** 48-74796  
**VDI 40** 48-77955



**Portabareno semilavorato**  
 48-81080

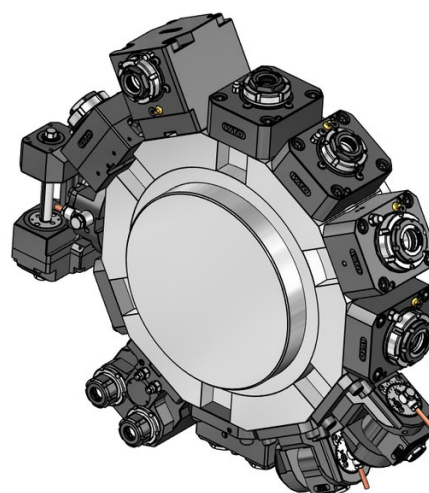
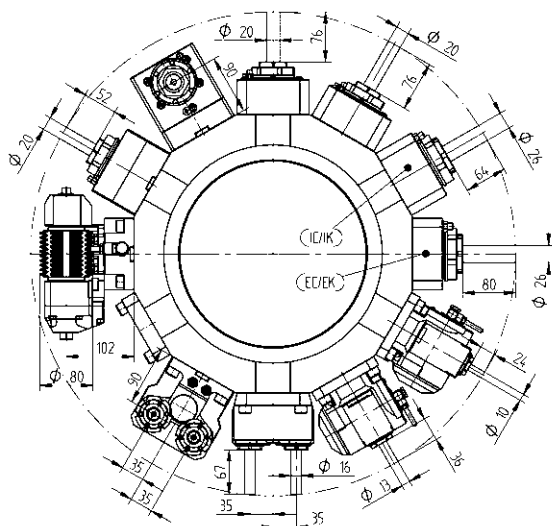

Portautensili Rotanti - QuickFlex®



**Portautensile rotante di foratura/fresatura (12000 RPM)**

- ER-32 QF QF32-DNE-MS60A-072-E-HS-A 1:1 EC  
0067732000
- ER-32 QF QF32-DNE-MS60A-072-I-HS-A 1:1 IC 100 bar  
0067732000



**Portautensile rotante di foratura/fresatura (12000 RPM) - QF smart (UE, US, CA, JP)**

- ER-32 QF QF32-DNE-MS60A-072-I-HS-SB-A 1:1 IC 100 bar  
0067732000
- LI-F12-01



**Portautensile rotante di foratura/fresatura (6000 RPM, Heavy Duty)**

- ER-32 QF 420132011-60 T32232, T32478 1:1 IC 80 bar  
0067732000
- ER-40 QF 420140010-60 T32213 1:1 EC  
0067740000
- ER-40 QF 420140011-60 T32234 1:1 IC 80 bar  
0067740000



**Portautensile rotante radiale (12000 RPM)**

- ER-32 QF QF32-DNI-MS60A-090-E-HS-A 1:1 EC  
0067732000
- ER-32 QF QF32-DNI-MS60A-090-I-HS-A 1:1 IC 100 bar  
0067732000

Portautensili Rotanti - QuickFlex®



**Portautensile rotante di foratura/fresatura (12000 RPM) - QF smart (UE, US, CA, JP)**

- ER-32 QF QF32-DNI-MS60A-090-I-HS-SB-A 1:1 IC 100 bar  
0067732000
- LI-F12-01



**Portautensile rotante di foratura/fresatura (6000 RPM, Heavy Duty)**

- ER-40 QF 420540012-60 T32214 1:1 EC  
0067740000
- ER-40 QF 420540013-60 T32235 1:1 IC 80 bar  
0067740000

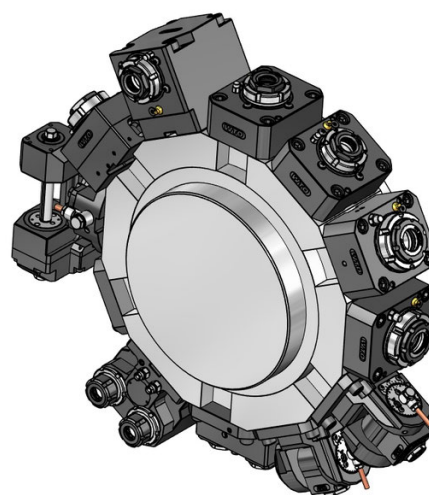
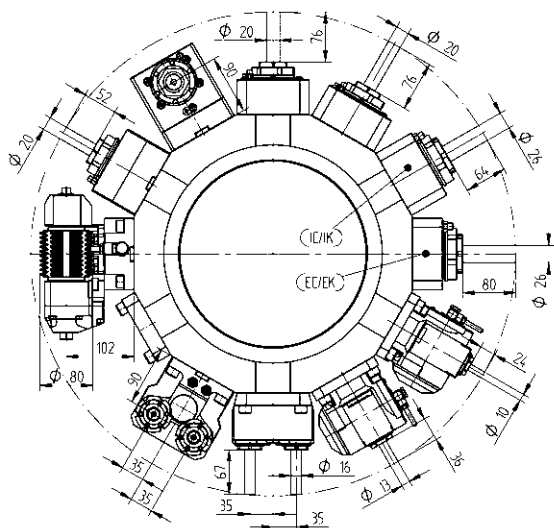

Portautensili Rotanti - Estensione del programma



**Portautensile rotante di fresatura con attacco combinato DIN 6358**

<b>Ø 16</b>	410216000-60 00675000854	1:1	EC
<b>Ø 22</b>	410222007-60 T32268 00675000483	1:1	EC
<b>Ø 27</b>	410227008-60 00675000245	1:1	EC



**Portautensile rotante di foratura/fresatura, disassato**

<b>ER-32 QF</b>	420132019-60 0067732000	1:1	EC
<b>ER-32 QF</b>	420132020-60 0067732000	1:1	IC 80 bar
<b>ER-25 QF</b>	420125010-60 0067725001	1:2	EC
<b>ER-25 QF</b>	420125011-60 0067725001	1:2	IC 80 bar
<b>ER-32 QF</b>	420132021-60 0067732000	2:1	EC
<b>ER-32 QF</b>	420132022-60 0067732000	2:1	IC 80 bar

Portautensili Rotanti - Estensione del programma



**Portautensile rotante di foratura/fresatura**

<b>ER-25 QF</b>	QF25-DNI-MS60A-090-E-S-A 0067725001	1:2	EC
<b>ER-25 QF</b>	QF25-DNI-MS60A-090-I-S-A 0067725001	1:2	IC 100 bar
<b>ER-40 QF</b>	420540014-60 0067740000	2:1	EC
<b>ER-40 QF</b>	420540015-60 0067740000	2:1	IC 80 bar



**Portautensile rotante orientabile di foratura/fresatura**

<b>ER 20</b>	411013009-60 T32474 00675000928	1:1	EC
<b>ER 20</b>	411013010-60 00675000928	1:1	IC 80 bar
<b>ER 16</b>	411010001-60 00675000936	1:2	EC
<b>ER 16</b>	411010002-60 00675000936	1:2	IC 80 bar

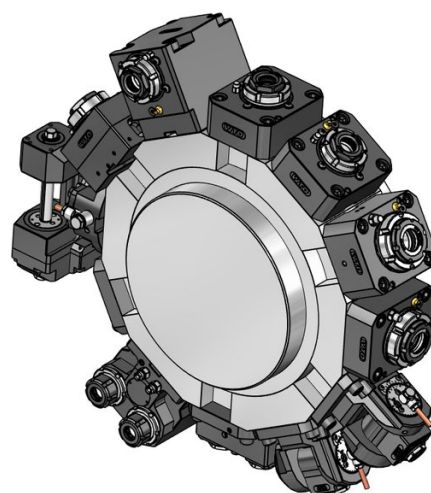
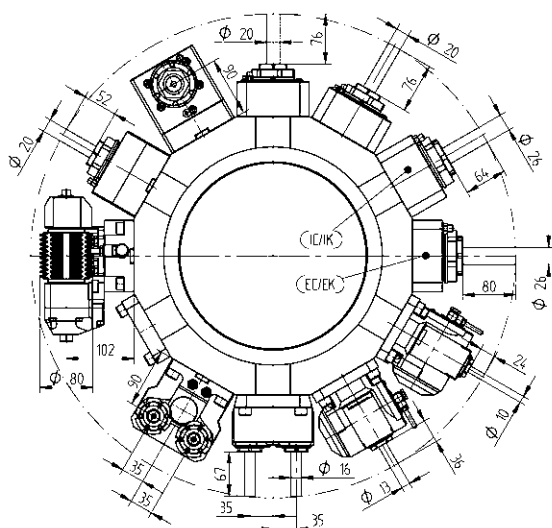

Portautensili Rotanti - Estensione del programma

Portautensili Rotanti - Estensione del programma



**Portautensile rotante portafrese a disco**

<b>Tipo 19-2</b>	411500006-60	3:1	EC
	00675000855		
	160022192 Ø 22		
	160027192 Ø 27		
	160032192 Ø 32		
	160040192 Ø 40		
	160023192 Ø 7/8"		
	160025192 Ø 1"		
	160031192 Ø 1 1/4"		
	160038192 Ø 1 1/2"		



**Unità porta creatore**

<b>Tipo 16-1</b>	411500007-60	1:1	EC
<b>Tipo 16-1</b>	411500008-60	2:1	EC
	00675000926		
	160016161 Ø 16		
	160022161 Ø 22		
	160027161 Ø 27		
	160015161 Ø 5/8"		
	160019161 Ø 3/4"		
	160025161 Ø 1"		
	160031161 Ø 1 1/4"		
	110587		



**Portautensile rotante di foratura/fresatura - doppio, asse Y**

<b>ER 25</b>	413002000-60 T32267	1:1	EC
	00675000907		
<b>ER 25</b>	413002012-60	1:1	IC 80 bar
	00675000907		



**Portautensile rotante di foratura/fresatura a 2 uscite, asse Y**

<b>ER 25</b>	413502000-60 T32264	1:1	EC
	00675000915		
<b>ER 25</b>	413502002-60	1:1	IC 80 bar
	00675000915		



**Unità di brocciatura per interni ed esterni**

<b>Tipo 32</b>	414532000-60	1:1	EC
<b>Tipo 52</b>	414552000-60	1:1	EC

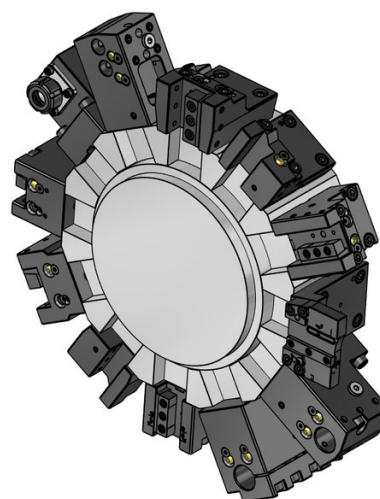
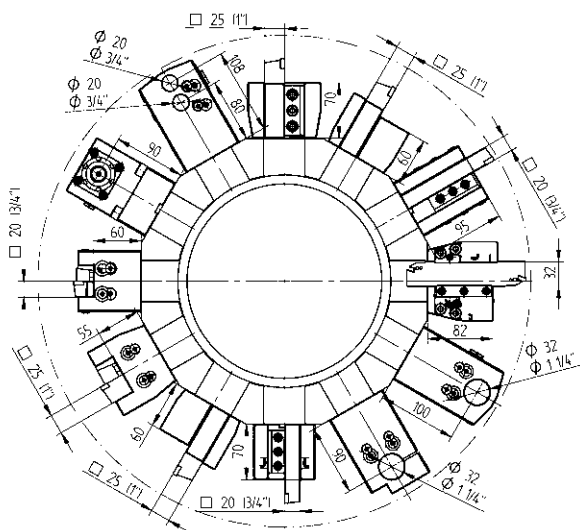

Portautensili statici - Programma standard



**Portautensile corto**

- 20 48-T00224  
T00224
- 25 48-T00267  
T00267



**Portautensile corto, HP-IC**

- 20 48-T00224-HP IC 80 bar  
T00224
- 25 48-T00267-HP IC 80 bar  
T00267



**Portautensile lungo**

- 20 48-T00225  
T00225



**Portautensile per esterni**

- 25 48-T03024  
T03024



**Portautensile per esterni, HP-IC**

- 20 48-T03017-HP IC 80 bar  
T03017

Portautensili statici - Programma standard



**Portautensile da taglio, destro**

- 20 48-T00251  
T00251
- 25 48-T00268  
T00268, T00356



**Portabareno**

- Ø 32 48-T10115  
T10115



**Portautensile combinato**

- Ø 32 48-T13132 IC 80 bar  
T13132
- Ø 40 48-77999 IC 80 bar

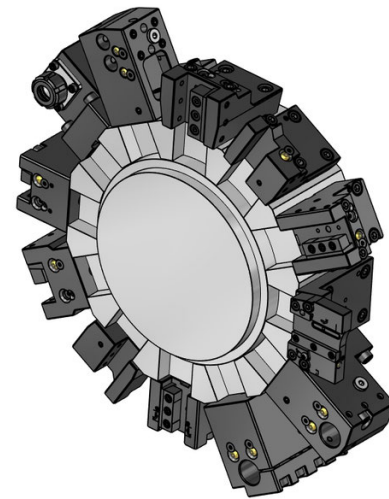
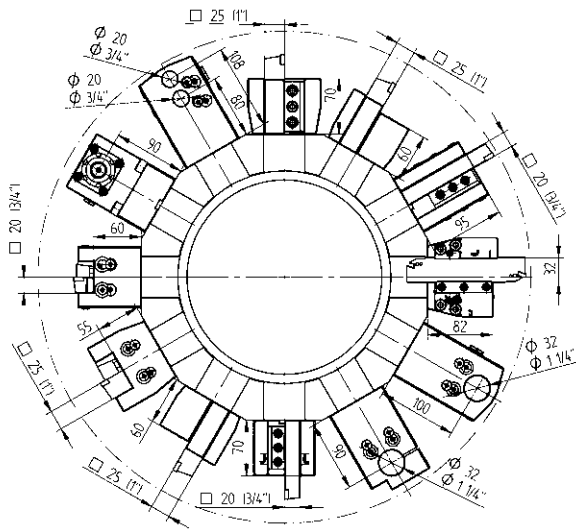

Portautensili statici - Estensione del programma

Portautensili statici - Estensione del programma



SH 32

**Portautensile da taglio, con regolazione**

48-98891



SH 32

**Portautensile da taglio, con regolazione, HP-IC**

SH 32

48-102261R

IC 80 bar

48-102261L

IC 80 bar



Ø 32

**Portabareno con serraggio a morsetto**

Ø 40

48-82057

48-82058



Ø 20

**Portabareno doppio per lavorazione su mandrino e contromandrino**

48-75406



ER 25

**Portapinzine di foratura**

48-107230

IC 80 bar

107525000

ER 32

48-81031

IC 80 bar

107532000



VDI 30

**Adattatore VDI, sinistro**

48-77732



VDI 30

**Adattatore VDI, destro**

48-78687



48-80506

**Portabareno semilavorato**

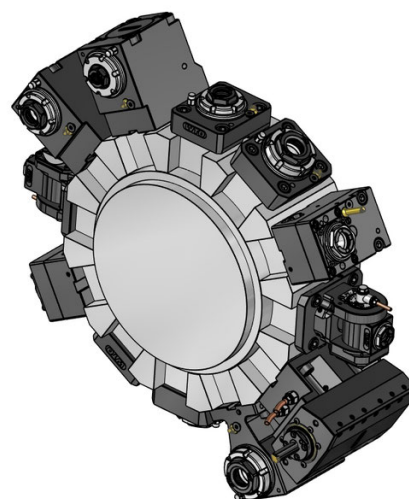
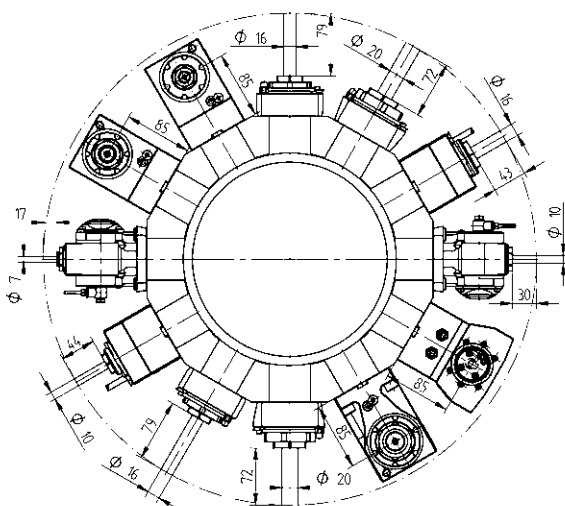

Portautensili Rotanti - QuickFlex®



**Portautensile rotante di foratura/fresatura (12000 RPM)**

- ER-25 QF** 420125012-40 T32433 1:1 EC  
0067725000
- ER-25 QF** 420125013-40 T32433 1:1 IC 80 bar  
0067725000
- ER-32 QF** QF32-DNE-MS40A-050-E-HS-A 1:1 EC  
0067732000
- ER-32 QF** QF32-DNE-MS40A-067-I-HS-A 1:1 IC 100 bar  
0067732000



**Portautensile rotante di foratura/fresatura (12000 RPM) - QF smart (UE, US, CA, JP)**

- ER-32 QF** QF32-DNE-MS40A-067-I-HS-SB-A 1:1 IC 100 bar  
0067732000  
LI-F12-01



**Portautensile rotante di foratura/fresatura (6000 RPM, Heavy Duty)**

- ER-25 QF** 420125010-40 T32274, T32450 1:1 EC  
0067725000
- ER-25 QF** 420125011-40 T32287 1:1 IC 80 bar  
0067725000
- ER-32 QF** 420132010-40 T32475, T32484 1:1 EC  
0067732000
- ER-32 QF** 420132011-40 T32476, T32485 1:1 IC 80 bar  
0067732000

Portautensili Rotanti - QuickFlex®



**Portautensile rotante di foratura/fresatura (12000 RPM)**

- ER-25 QF** 420525013-40 T32434 1:1 EC  
0067725000
- ER-25 QF** 420525014-40 T32436 1:1 IC 80 bar  
0067725000
- ER-32 QF** QF32-DNI-MS40A-085-E-HS-A 1:1 EC  
0067732000
- ER-32 QF** QF32-DNI-MS40A-085-I-HS-A 1:1 IC 100 bar  
0067732000



**Portautensile rotante di foratura/fresatura (12000 RPM) - QF smart (UE, US, CA, JP)**

- ER-32 QF** QF32-DNI-MS40A-085-I-HS-SB-A 1:1 IC 100 bar  
0067732000  
LI-F12-01



**Portautensile rotante di foratura/fresatura (6000 RPM, Heavy Duty)**

- ER-25 QF** 420525010-40 T32275, T32297 1:1 EC  
0067725000
- ER-25 QF** 420525011-40 T32288, T32435 1:1 IC 80 bar  
0067725000
- ER-32 QF** 420532010-40 T32476, T32485 1:1 EC  
0067732000



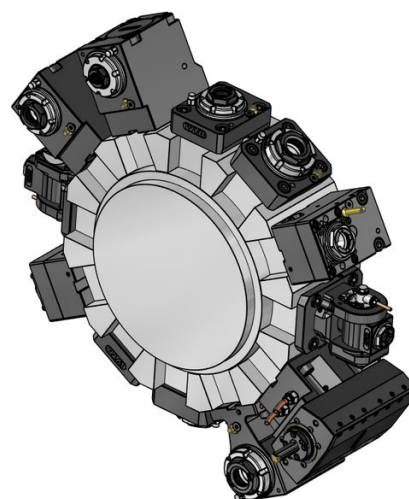
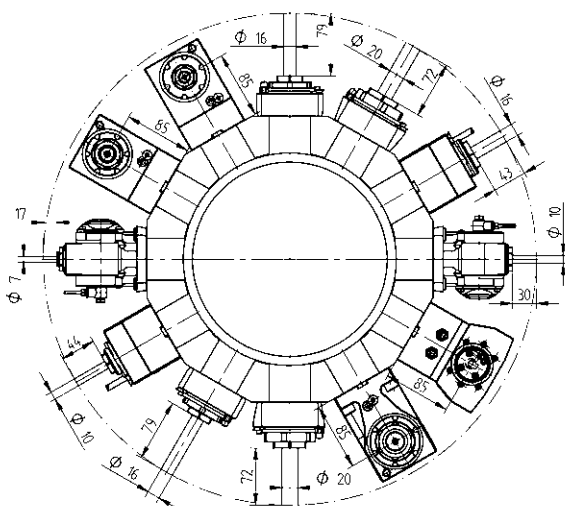

Portautensili Rotanti - Estensione del programma



**Portautensile rotante di foratura/fresatura, disassato**

<b>ER 25</b>	410116050-40 T32488	1:1	EC
	00675000932		
<b>ER 25</b>	410116057-40	1:1	IC 80 bar
	00675000932		
<b>ER 20</b>	410113060-40	1:2	EC
	00675000939		
<b>ER 20</b>	410113068-40	1:2	IC 80 bar
	00675000939		
<b>ER 16</b>	410410003-40	1:3	EC
	00675000937		
<b>ER 16</b>	410410004-40	1:3	IC 80 bar
	00675000937		
<b>ER 25</b>	410116051-40	2:1	EC
	00675000932		
<b>ER 25</b>	410116058-40	2:1	IC 80 bar
	00675000932		



**Portautensile rotante di foratura/fresatura, disassato (12000 RPM)**

<b>ER 25</b>	410116060-40	1:1	EC
	00675000932		
<b>ER 25</b>	410116059-40	1:1	IC 80 bar
	00675000932		

Portautensili Rotanti - Estensione del programma



**Portautensile rotante di foratura/fresatura**

<b>ER-20 QF</b>	420520010-40	1:2	EC
	0067720001		
<b>ER-20 QF</b>	420520011-40	1:2	IC 80 bar
	0067720001		
<b>ER 16</b>	410810012-40	1:3	EC
	0067825001		
<b>ER 16</b>	410810013-40	1:3	IC 80 bar
	0067825001		
<b>ER-32 QF</b>	420532013-40	2:1	EC
	0067732000		
<b>ER-32 QF</b>	QF32-DNI-MS40A-085-I-T-A	2:1	IC 100 bar
	0067732000		

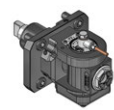

**Portautensile rotante orientabile di foratura/fresatura**

<b>ER 16</b>	411010008-40	1:1	EC
	00675000913		
<b>ER 16</b>	411010009-40	1:1	IC 80 bar
	00675000913		
<b>ER 11</b>	411007001-40	1:2	EC
	00675000914		
<b>ER 11</b>	411007002-40	1:2	IC 80 bar
	00675000914		



**Unità di brocciatura per interni ed esterni**

<b>Tipo 32</b>	414532000-40	1:1	EC
----------------	--------------	-----	----



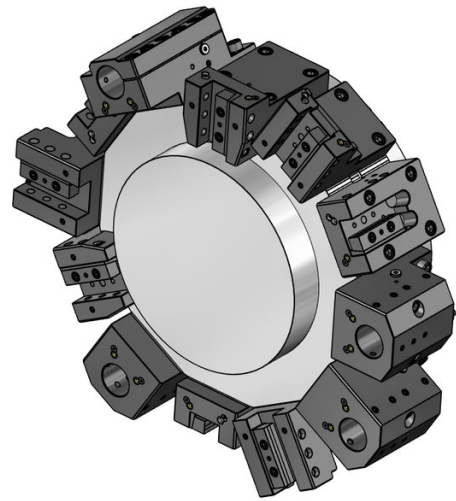
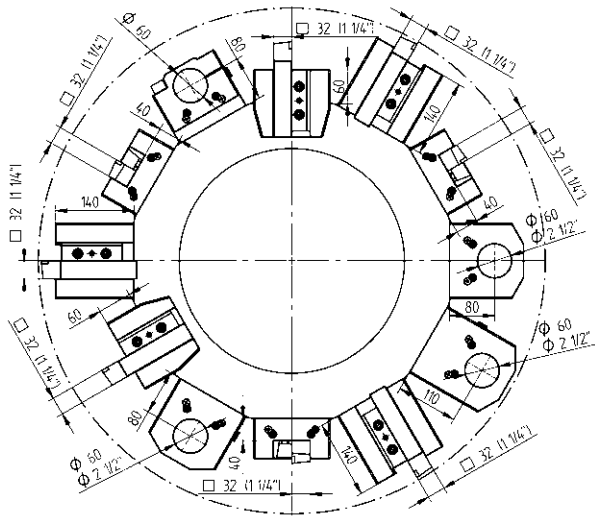

Portautensili statici - Programma standard



**Portautensile**  
32 48-T00432  
T00432



**Portautensile lungo (solo per torretta 1)**  
32 48-T00434  
T00434



**Portautensile per esterni**  
32 48-T03042  
T03042

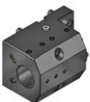

**Portautensile combinato, LF=80**  
Ø 60 48-T10203 IC 80 bar  
T10203  
Ø 80 48-115987 IC 80 bar



**Portautensile combinato, LF=110**  
Ø 60 48-T12149 IC 80 bar  
T12149

Portautensili statici - Estensione del programma



**Portabareno con serraggio a morsetto**  
Ø 60 48-108639



**Portabareno con serraggio a morsetto (solo per torretta 1)**  
Ø 80 48-118772

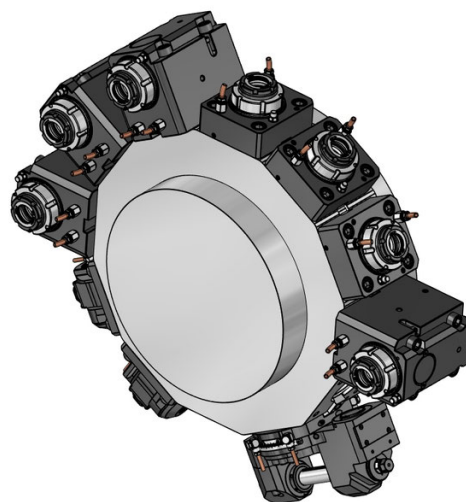
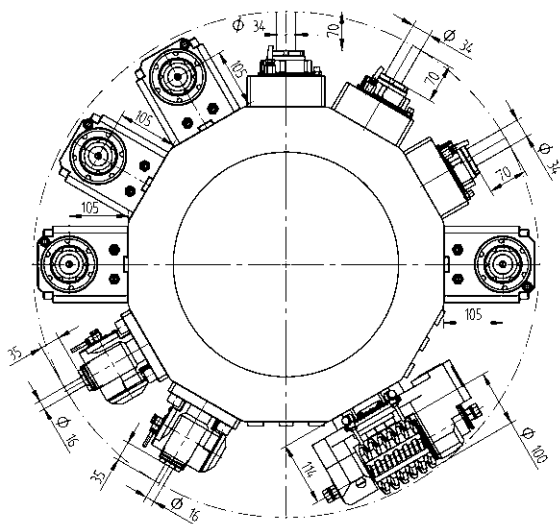

Portautensili Rotanti - QuickFlex®



**Portautensile rotante di foratura/fresatura assiale (8000 RPM)**

- |                 |                        |     |           |
|-----------------|------------------------|-----|-----------|
| <b>ER-50 QF</b> | 420150012-75<br>T32659 | 1:1 | EC        |
|                 | 0067750000             |     |           |
| <b>ER-50 QF</b> | 420150013-75           | 1:1 | IC 80 bar |
|                 | 0067750000             |     |           |



**Portautensile rotante radiale di foratura/fresatura (8000 RPM)**

- |                 |                        |     |           |
|-----------------|------------------------|-----|-----------|
| <b>ER-50 QF</b> | 420550012-75<br>T32660 | 1:1 | EC        |
|                 | 0067750000             |     |           |
| <b>ER-50 QF</b> | 420550013-75           | 1:1 | IC 80 bar |
|                 | 0067750000             |     |           |

Portautensili Rotanti - Estensione del programma



**Portautensile rotante orientabile di foratura/fresatura**

- |              |              |     |           |
|--------------|--------------|-----|-----------|
| <b>ER 25</b> | 411016002-75 | 1:1 | EC        |
|              | 00675000934  |     |           |
| <b>ER 25</b> | 411016003-75 | 1:1 | IC 80 bar |
|              | 00675000934  |     |           |
| <b>ER 16</b> | 411010004-75 | 1:2 | EC        |
|              | 00675000936  |     |           |
| <b>ER 16</b> | 411010005-75 | 1:2 | IC 80 bar |
|              | 00675000936  |     |           |



**Unità porta creatore**

- |                  |                    |     |    |
|------------------|--------------------|-----|----|
| <b>Tipo C5-1</b> | 410900000-75       | 2:1 | EC |
|                  | 00675001008        |     |    |
|                  | 160022C51 Ø 22     |     |    |
|                  | 160027C51 Ø 27     |     |    |
|                  | 160032C51 Ø 32     |     |    |
|                  | 160019C51 Ø 3/4"   |     |    |
|                  | 160025C51 Ø 1"     |     |    |
|                  | 160031C51 Ø 1 1/4" |     |    |
|                  | 110587             |     |    |

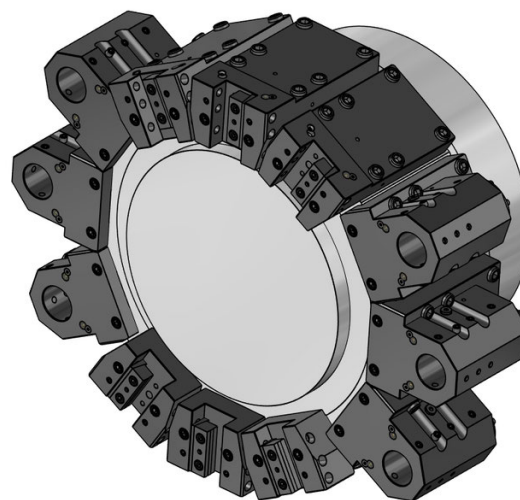
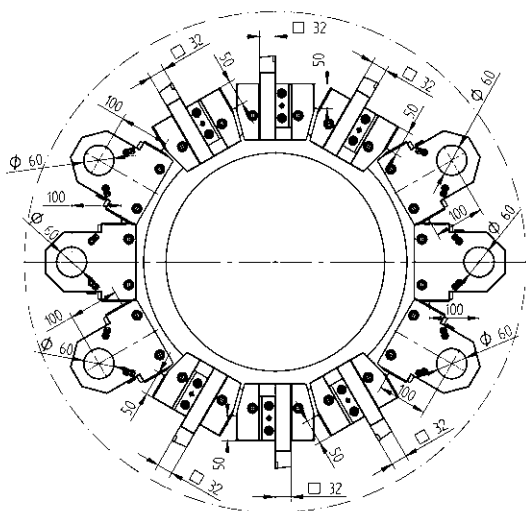

Portautensili statici - Programma standard



32

**Portautensile**

48-T00372  
T00372



Ø 60

**Portautensile combinato**

48-T10168                      IC 80 bar  
T10168

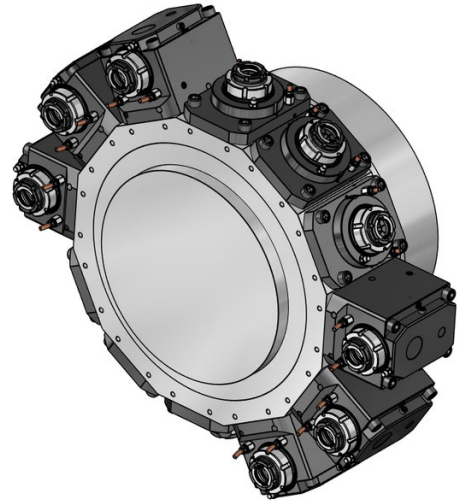
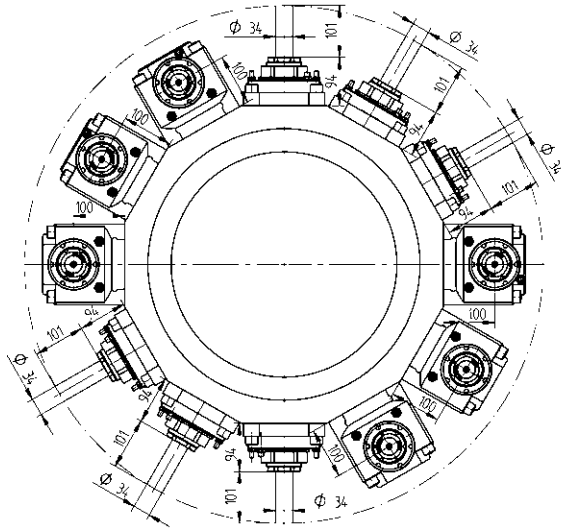

Portautensili Rotanti - Performance Series



**Portautensile rotante di foratura/fresatura**

- |              |                        |     |           |
|--------------|------------------------|-----|-----------|
| <b>ER 50</b> | 420150000-A1<br>T32495 | 1:1 | EC        |
|              | 0067550000             |     |           |
| <b>ER 50</b> | 420150001-A1           | 1:1 | IC 80 bar |
|              | 0067550000             |     |           |



**Portautensile rotante di foratura/fresatura**

- |              |                        |     |           |
|--------------|------------------------|-----|-----------|
| <b>ER 50</b> | 420550000-A1<br>T32496 | 1:1 | EC        |
|              | 0067550000             |     |           |
| <b>ER 50</b> | 420550001-A1           | 1:1 | IC 80 bar |
|              | 0067550000             |     |           |

Portautensili Rotanti - QuickFlex®



**Portautensile rotante di foratura/fresatura**

- |                 |                        |     |           |
|-----------------|------------------------|-----|-----------|
| <b>ER-50 QF</b> | 420150010-A1<br>T32495 | 1:1 | EC        |
|                 | 0067750000             |     |           |
| <b>ER-50 QF</b> | 420150011-A1           | 1:1 | IC 80 bar |
|                 | 0067750000             |     |           |

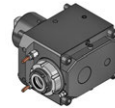

**Portautensile rotante di foratura/fresatura**

- |                 |                        |     |           |
|-----------------|------------------------|-----|-----------|
| <b>ER-50 QF</b> | 420550010-A1<br>T32496 | 1:1 | EC        |
|                 | 0067750000             |     |           |
| <b>ER-50 QF</b> | 420550011-A1           | 1:1 | IC 80 bar |
|                 | 0067750000             |     |           |

Bussole cilindriche standard di riduzione



**Bussola di riduzione Ø 20**

240020006	ø 6
240020008	ø 8
240020010	ø 10
240020012	ø 12
240020014	ø 14
240020016	ø 16



**Bussola di riduzione Ø 25**

240025006	ø 6
240025008	ø 8
240025010	ø 10
240025012	ø 12
240025014	ø 14
240025016	ø 16
240025020	ø 20



**Bussola di riduzione Ø 32**

240032006	ø 6
240032008	ø 8
240032010	ø 10
240032012	ø 12
240032014	ø 14
240032016	ø 16
240032018	ø 18
240032020	ø 20
240032025	ø 25



**Bussola di riduzione Ø 40**

240040006	ø 6
240040008	ø 8
240040010	ø 10
240040012	ø 12
240040014	ø 14
240040016	ø 16
240040020	ø 20
240040025	ø 25
240040032	ø 32



**Bussola di riduzione Ø 50**

240050010	ø 10
240050012	ø 12
240050016	ø 16
240050020	ø 20
240050025	ø 25
240050032	ø 32
240050040	ø 40

Bussole cilindriche standard di riduzione con cava



**Bussola di riduzione Ø 25**

240125006	ø 6
240125008	ø 8
240125010	ø 10
240125012	ø 12
240125014	ø 14
240125015	ø 15
240125016	ø 16
240125020	ø 20



**Bussola di riduzione Ø 32**

240132008	ø 8
240132010	ø 10
240132012	ø 12
240132015	ø 15
240132016	ø 16
240132020	ø 20
240132025	ø 25



**Bussola di riduzione Ø 40**

240140010	ø 10
240140012	ø 12
240140015	ø 15
240140016	ø 16
240140020	ø 20
240140025	ø 25
240140032	ø 32



**Bussola di riduzione Ø 50**

240150020	ø 20
240150025	ø 25
240150032	ø 32
240150040	ø 40



**Bussola di riduzione Ø 60**

240160032	ø 32
240160040	ø 40
240160050	ø 50

Bussole di riduzione standard cono Morse



**Bussola di riduzione Ø 32**

240532001	MT 1
240532002	MT 2
240532003	MT 3

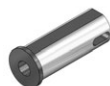

**Bussola di riduzione Ø 40**

240540001	MT 1
240540002	MT 2
240540003	MT 3
240540004	MT 4

Bussole di riduzione cilindriche portabareni



**Bussola di riduzione Ø 25**

24-T20180	ø 8
24-T20182	ø 10
24-T20184	ø 12
24-T20186	ø 16
24-T20188	ø 20



**Bussola di riduzione Ø 32**

24-T20112	ø 8
24-T20114	ø 10
24-T20116	ø 12
24-T20118	ø 16
24-T20120	ø 20
24-T20122	ø 25



**Bussola di riduzione Ø 40**

24-T20086	ø 8
24-T20088	ø 10
24-T20090	ø 12
24-T20092	ø 16
24-T20094	ø 20
24-T20096	ø 25
24-T20098	ø 32



**Bussola di riduzione Ø 50**

24-T20160	ø 10
24-T20162	ø 12
24-T20164	ø 16
24-T20166	ø 20
24-T20168	ø 25
24-T20170	ø 32
24-T20172	ø 40



**Bussola di riduzione Ø 60**

24-T20136	ø 32
24-T20138	ø 40
24-T20140	ø 50



Bussole di riduzione prolungate cilindriche portabareni prolungate



**Bussole di riduzione Ø 32**

24-T20124	Ø 8
24-T20126	Ø 10
24-T20128	Ø 12
24-T20130	Ø 16



**Bussole di riduzione Ø 40**

24-T20106	Ø 8
24-T20108	Ø 10
24-T20110	Ø 12
24-T20194	Ø 16
24-T20196	Ø 20
24-T20216	Ø 25

Bussole di riduzione con Morse portabareni



**Bussole di riduzione Ø 40**

24-T22046	MT 2
24-T22042	MT 3

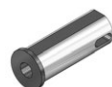

**Bussole di riduzione Ø 50**

24-T22044	MT 4
-----------	------

Pinze DIN 6499B (ER/ESX)

Pinze DIN 6499B (ER/ESX)



**ER 11**

190011000	∅ 7-0.5	∅ 0.276-0.020
190011010	∅ 1-0.5	∅ 0.039-0.020
190011015	∅ 1.5-1	∅ 0.059-0.039
190011020	∅ 2-1.5	∅ 0.079-0.059
190011025	∅ 2.5-2	∅ 0.098-0.079
190011030	∅ 3-2.5	∅ 0.118-0.098
190011035	∅ 3.5-3	∅ 0.138-0.118
190011040	∅ 4-3.5	∅ 0.158-0.138
190011045	∅ 4.5-4	∅ 0.177-0.158
190011050	∅ 5-4.5	∅ 0.197-0.177
190011055	∅ 5.5-5	∅ 0.217-0.197
190011060	∅ 6-5.5	∅ 0.236-0.217
190011065	∅ 6.5-6	∅ 0.256-0.236
190011070	∅ 7-6.5	∅ 0.276-0.256



**ER 25**

190025000	∅ 16-1	∅ 0.630-0.039
190025010	∅ 1-0.5	∅ 0.039-0.020
190025020	∅ 2-1	∅ 0.079-0.039
190025030	∅ 3-2	∅ 0.118-0.079
190025040	∅ 4-3	∅ 0.157-0.118
190025050	∅ 5-4	∅ 0.197-0.157
190025060	∅ 6-5	∅ 0.236-0.197
190025070	∅ 7-6	∅ 0.276-0.236
190025080	∅ 8-7	∅ 0.315-0.276
190025090	∅ 9-8	∅ 0.354-0.315
190025100	∅ 10-9	∅ 0.394-0.354
190025110	∅ 11-10	∅ 0.433-0.394
190025120	∅ 12-11	∅ 0.472-0.433
190025130	∅ 13-12	∅ 0.512-0.472
190025140	∅ 14-13	∅ 0.551-0.512
190025150	∅ 15-14	∅ 0.591-0.551
190025160	∅ 16-15	∅ 0.630-0.591



**ER 16**

190016000	∅ 10-0.5	∅ 0.394-0.020
190016010	∅ 1-0.5	∅ 0.039-0.020
190016020	∅ 2-1	∅ 0.079-0.039
190016030	∅ 3-2	∅ 0.118-0.079
190016040	∅ 4-3	∅ 0.158-0.118
190016050	∅ 5-4	∅ 0.197-0.158
190016060	∅ 6-5	∅ 0.236-0.197
190016070	∅ 7-6	∅ 0.276-0.236
190016080	∅ 8-7	∅ 0.315-0.276
190016090	∅ 9-8	∅ 0.354-0.315
190016100	∅ 10-9	∅ 0.394-0.354



**ER 32**

190032000	∅ 20-2	∅ 0.787-0.079
190032020	∅ 2-1	∅ 0.079-0.039
190032030	∅ 3-2	∅ 0.118-0.079
190032040	∅ 4-3	∅ 0.157-0.118
190032050	∅ 5-4	∅ 0.197-0.157
190032060	∅ 6-5	∅ 0.236-0.197
190032070	∅ 7-6	∅ 0.276-0.236
190032080	∅ 8-7	∅ 0.315-0.276
190032090	∅ 9-8	∅ 0.354-0.315
190032100	∅ 10-9	∅ 0.394-0.354
190032110	∅ 11-10	∅ 0.433-0.394
190032120	∅ 12-11	∅ 0.472-0.433
190032130	∅ 13-12	∅ 0.512-0.472
190032140	∅ 14-13	∅ 0.551-0.512
190032150	∅ 15-14	∅ 0.591-0.551
190032160	∅ 16-15	∅ 0.630-0.591
190032170	∅ 17-16	∅ 0.669-0.630
190032180	∅ 18-17	∅ 0.709-0.669
190032190	∅ 19-18	∅ 0.748-0.709
190032200	∅ 20-19	∅ 0.787-0.748



**ER 20**

190020000	∅ 13-1	∅ 0.512-0.039
190020010	∅ 1-0.5	∅ 0.039-0.020
190020020	∅ 2-1	∅ 0.079-0.039
190020030	∅ 3-2	∅ 0.118-0.079
190020040	∅ 4-3	∅ 0.157-0.118
190020050	∅ 5-4	∅ 0.197-0.157
190020060	∅ 6-5	∅ 0.236-0.197
190020070	∅ 7-6	∅ 0.276-0.236
190020080	∅ 8-7	∅ 0.315-0.276
190020090	∅ 9-8	∅ 0.354-0.315
190020100	∅ 10-9	∅ 0.394-0.354
190020110	∅ 11-10	∅ 0.433-0.394
190020120	∅ 12-11	∅ 0.472-0.433
190020130	∅ 13-12	∅ 0.512-0.472

Pinze DIN 6499B (ER/ESX)



**ER 40**

190040000	ø 26-3	ø 1.024-0.118
190040030	ø 3-2	ø 0.118-0.079
190040040	ø 4-3	ø 0.157-0.118
190040050	ø 5-4	ø 0.197-0.157
190040060	ø 6-5	ø 0.236-0.197
190040070	ø 7-6	ø 0.276-0.236
190040080	ø 8-7	ø 0.315-0.276
190040090	ø 9-8	ø 0.354-0.315
190040100	ø 10-9	ø 0.394-0.354
190040110	ø 11-10	ø 0.433-0.394
190040120	ø 12-11	ø 0.472-0.433
190040130	ø 13-12	ø 0.512-0.472
190040140	ø 14-13	ø 0.551-0.512
190040150	ø 15-14	ø 0.591-0.551
190040160	ø 16-15	ø 0.630-0.591
190040170	ø 17-16	ø 0.669-0.630
190040180	ø 18-17	ø 0.709-0.669
190040190	ø 19-18	ø 0.748-0.709
190040200	ø 20-19	ø 0.787-0.748
190040210	ø 21-20	ø 0.827-0.787
190040220	ø 22-21	ø 0.866-0.827
190040230	ø 23-22	ø 0.906-0.866
190040240	ø 24-23	ø 0.945-0.906
190040250	ø 25-24	ø 0.984-0.945
190040260	ø 26-25	ø 1.024-0.984



**ER 50**

190050000	ø 34-10	ø 1.339-0.394
190050060	ø 6-4	ø 0.236-0.157
190050080	ø 8-6	ø 0.315-0.236
190050100	ø 10-8	ø 0.394-0.315
190050120	ø 12-10	ø 0.472-0.394
190050140	ø 14-12	ø 0.551-0.472
190050160	ø 16-14	ø 0.630-0.551
190050180	ø 18-16	ø 0.709-0.630
190050200	ø 20-18	ø 0.787-0.709
190050220	ø 22-20	ø 0.866-0.787
190050240	ø 24-22	ø 0.945-0.866
190050260	ø 26-24	ø 1.024-0.945
190050280	ø 28-26	ø 1.102-1.024
190050300	ø 30-28	ø 1.181-1.102
190050320	ø 32-30	ø 1.260-1.181
190050340	ø 32-30	ø 1.260-1.181

Pinze DIN 6499B (ER/ESX) - vulcanizzate per refrigerante



**ER 11**

191011030	ø 3
191011040	ø 4
191011050	ø 5
191011060	ø 6



**ER 16**

191016000	ø 3-10
191016030	ø 3
191016040	ø 4
191016050	ø 5
191016060	ø 6
191016070	ø 7
191016080	ø 8
191016090	ø 9
191016100	ø 10



**ER 20**

191020000	ø 3-12
191020030	ø 3
191020040	ø 4
191020050	ø 5
191020060	ø 6
191020070	ø 7
191020080	ø 8
191020090	ø 9
191020100	ø 10
191020110	ø 11
191020120	ø 12



**ER 25**

191025000	ø 4-16
191025030	ø 3
191025040	ø 4
191025050	ø 5
191025060	ø 6
191025070	ø 7
191025080	ø 8
191025090	ø 9
191025100	ø 10
191025110	ø 11
191025120	ø 12
191025130	ø 13
191025140	ø 14
191025150	ø 15
191025160	ø 16

Pinze DIN 6499B (ER/ESX) - vulcanizzate  
per refrigerante



**ER 32**

191032000	ø 4-20
191032030	ø 3
191032040	ø 4
191032050	ø 5
191032060	ø 6
191032070	ø 7
191032080	ø 8
191032090	ø 9
191032100	ø 10
191032110	ø 11
191032120	ø 12
191032130	ø 13
191032140	ø 14
191032150	ø 15
191032160	ø 16
191032170	ø 17
191032180	ø 18
191032190	ø 19
191032200	ø 20



**ER 40**

191040060	ø 6
191040080	ø 8
191040100	ø 10
191040120	ø 12
191040140	ø 14
191040160	ø 16
191040180	ø 18
191040200	ø 20
191040220	ø 22
191040250	ø 25







## Qualità senza compromessi.

Tutte le fasi di lavorazione sono eseguite alla perfezione.

Dalla fase di progettazione fino alla fine della produzione non facciamo compromessi in termini di qualità.

I nostri prodotti sono costantemente controllati con macchine di misura 3D durante tutte le fasi del ciclo di produzione.

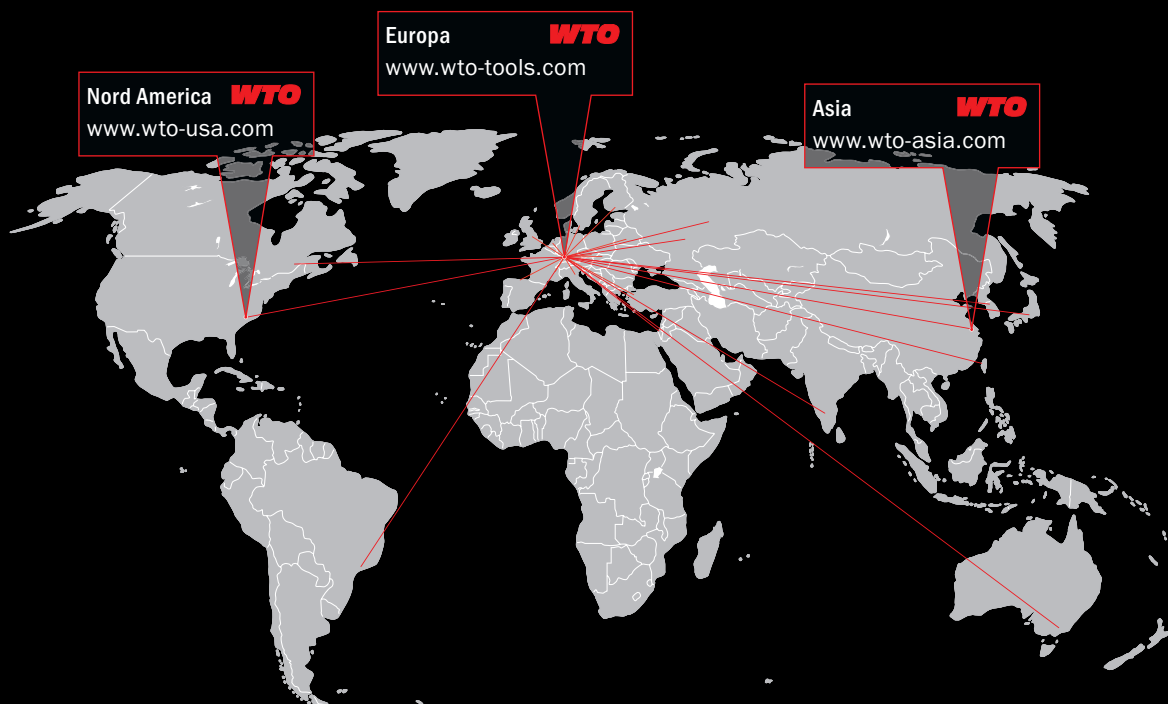

WTO  
Werkzeug-  
Einrichtungen GmbH  
Neuer Hohdammweg 1  
77797 Ohlsbach  
Germania

WTO Inc.  
13900-F South Lakes Dr.  
Charlotte, NC 28273  
Stati Uniti d'America

WTO Asia  
WTO Precision Tool Holders  
(Shanghai) Co. Ltd.  
Room 109-110, Building 2  
No. 228 Banting Road  
Jiuting Town,  
Songjiang District  
201615 Shanghai  
Cina

## Our distribution partners. Competence right there.

**Australia**  
Dimac Tooling Ltd.  
sales@dimac.com.au

**Francia, est**  
Alexandre Mathelin  
alm@wto.de

**Korea**  
WTO Office Korea  
is.chon@wto-korea.com

**Spain**  
ITALMATIC, S.A.  
italmatic@italmatic.es

**Brazil**  
TF2  
tfdois@tfdois.com.br

**Francia, ovest**  
Christophe Archambault  
car@wto.de

**Messico**  
Workholding Engineering De México  
info@wem.com.mx

**Sweden**  
Bonthron & Ewing AB  
info@bonthron-ewing.se

**Canada**  
Mittmann Industrial Inc.  
info@mittmann.com

**Great Britain**  
Cutwel Ltd.  
sales@cutwel.net

**Netherlands**  
Toologic BeNeLux B.V.  
info@toologic-benelux.nl

**Switzerland**  
Utilis AG  
info@utilis.com

**China**  
Shanghai Gangde  
wtocando@yahoo.com

**India**  
Ulhas Patil  
u.patil@wto-asia.com

**Norway**  
Helge Karlsen Verktøy og Maskin AS  
hkvm@hkvm.no

**Taiwan**  
Kaiko Co., Ltd.  
info@kaiko.com.tw

**Czech Republic**  
ALBA precision, spol. s.r.o.  
info@albaprecision.cz

**Israel**  
E.Y.A.R. Ltd.  
boris@eyar.co.il

**Polonia**  
ARCO Andrzej Rudenko  
info@arcotools.pl

**Turkey**  
MYK CNC MAKINA SAN. VE  
huseyin.tatlidil@mykcnc.com.tr

**Denmark**  
AVN Teknik A/S  
cjo@avn.dk

**Italy**  
Prymark srl  
commerciale@prymark.it

**Romania**  
SC Elif Trading SRL  
bulent.ozkan@eliftrading.com

**Ukraine**  
„LLC“ SPA Stankopromimport  
info@phoenix-ua.com

**Finland**  
Suomen Terätuonti Oy  
myynti@stt.as

**Japan**  
NK Works Co. Ltd.  
k\_samba@nk-works.co.jp

**Slowakia**  
ALBA precision s.r.o.  
albaprecision@albaprecision.sk

**Ungheria**  
Prevotex Hungary Kft.  
info@prevotex.hu