

刀座目錄

CLX/CTX 350 V3-V4, T1
CLX/CTX 350 V6
CLX/CTX 450/550 V3-V4, T2
CLX/CTX 450/550/750 V6
CTX 2500 V3-V4
CTX 2500 V6
Sprint 50
Sprint 65

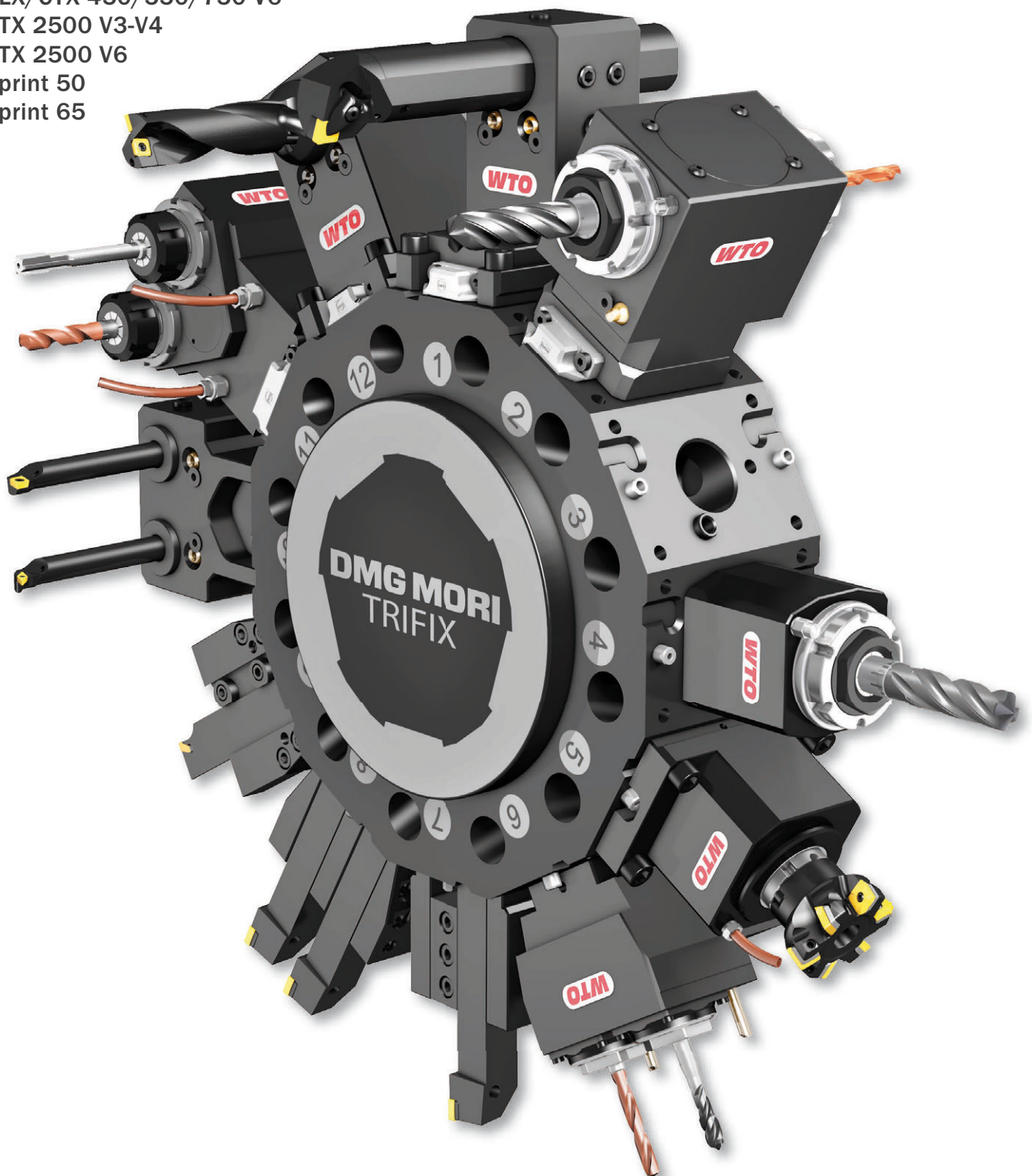

Trifix®



QuickFlex®

新快換系統
高效能精密加工.

最小的投資，最大的擴充性.

Designed
for
Trifix®

CLX/CTX 350 V3-V4, T1	頁	4 - 6
CLX/CTX 350 V6	頁	7 - 13
CLX/CTX 450/550 V3-V4, T2	頁	14 - 17
CLX/CTX 450/550/750 V6	頁	18 - 26
CTX 2500 V3-V4	頁	27 - 30
CTX 2500 V6	頁	31 - 39
Sprint 50	頁	40 - 44
Sprint 65	頁	45 - 51
變徑套	頁	52 - 53
筒夾	頁	54 - 56

EC = 外部出水冷卻
HP-IC = 高壓, 刀具中心出水冷卻
IC 80 bar = 高壓, 刀具中心出水冷卻及外部出水冷卻
最高切削液壓力 = 80 bar
IC 30 bar = 刀具中心出水冷卻及外部出水冷卻
最高切削液壓力 = 30 bar
切削液系統過濾網目需小於50µm
刀座運轉前一定要開啟冷卻液系統! 不可無水運轉!
請勿使用在鑄鐵或粉狀切屑工件加工

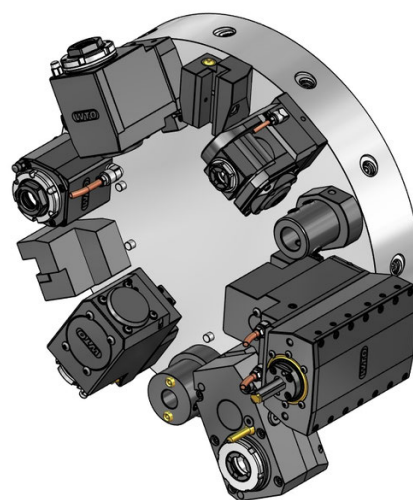
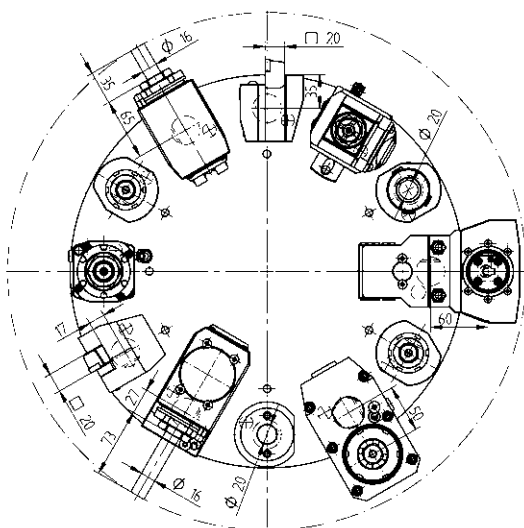

固定刀座 - 標準產品目錄



20(16)
20(16)

徑向右手方形刀座, 短型, B1型式

48-B1-30x20
48-B1-30x20x60

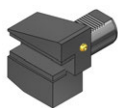

20(16)

徑向右手方形刀座, 反刀, 短型, B3型式

48-B3-30x20



20(16)

徑向右手方形刀座, 長型, B5型式

48-B5-30x20



20(16)

徑向右手方形刀座, 反刀, 長型, B7型式

48-B7-30x20



20
20

徑向方形刀座, HP-IC - VDI 雙面排齒

48-105980R-HP IC 80 bar
48-105980L-HP IC 80 bar



20(16)

方形刀柄軸向刀座, 右手刀, C1型式

48-C1-30x20



20(16)

方形刀柄軸向刀座, 右手反刀, C3型式

48-C3-30x20

固定刀座 - 標準產品目錄



SH 26

切斷刀用刀座, 中心高可微調, 中心出水, HP-IC

48-102686R IC 80 bar
343-810100R43

SH 26

48-102686L IC 80 bar
343-810100L43

SH 32

48-102688R IC 80 bar

SH 32

48-102688L IC 80 bar



Ø 16

捨棄式刀片鑽頭刀座, 中心出水, E1型式

48-E1-30x16

Ø 20 48-E1-30x20

Ø 25 48-E1-30x25

Ø 32 48-E1-30x32



Ø 8

搪刀刀座, 中心出水, E2型式

48-E2-30x8

Ø 10 48-E2-30x10

Ø 12 48-E2-30x12

Ø 16 48-E2-30x16

Ø 20 48-E2-30x20

Ø 25 48-E2-30x25

Ø 32 48-E2-30x32



ER 20

ER筒夾刀座, DIN 6499B, 中心出水, E4型式

48-E4-30x20

ER 25 48-E4-30x25

107525000

ER 32 48-E4-30x32

107532000

ER 40 48-E4-30x40

107540000

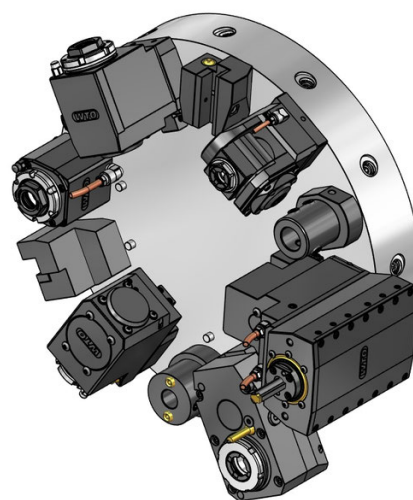
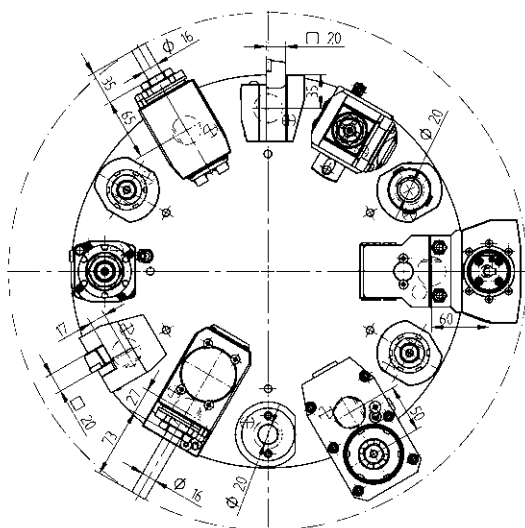

動力刀座 - QuickFlex® 產品目錄

- 

直結式鑽/銑動力刀座

ER-25 QF	420125010-30R	1:1	EC
	 0067725010		
ER-25 QF	420125019-30R	1:1	IC 80 bar
	 0067725010		

- 

直角式鑽/銑動力刀座

ER-25 QF	420525066-30R	1:1	EC
	 0067725010		
ER-25 QF	420525067-30R	1:1	IC 80 bar
	 0067725010		

- 

直角後縮式鑽/銑動力刀座

ER-25 QF	420525062-30R	1:1	EC
	 0067725010		
ER-25 QF	420525063-30R	1:1	IC 80 bar
	 0067725010		

動力刀座 - 進階產品目錄

- 

直結式銑刀座

Ø 16	410216014-30	1:1	EC
	 00675000854		



- 

直結偏位式鑽/銑動力刀座

ER 25	410116094-30	1:1	EC
	 00675000801		
ER 25	410116095-30	1:1	IC 80 bar
	 00675000801		
ER 20	410113029-30	1:2	EC
	 00675000591		
ER 20	410113030-30	1:2	IC 80 bar
	 00675000591		
ER 32	410120035-30	2:1	EC
	 00675000592		
ER 32	410120036-30	2:1	IC 80 bar
	 00675000592		

- 

直結偏位式鑽/銑動力刀座 - VDI 雙面排齒

ER 16	410410002-30	1:3	EC
	 00675000937		
ER 16	410410001-30	1:3	IC 80 bar
	 00675000937		

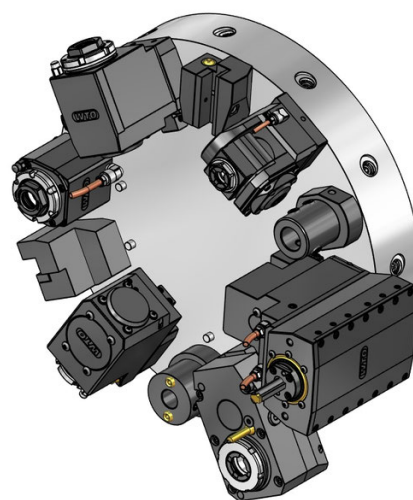
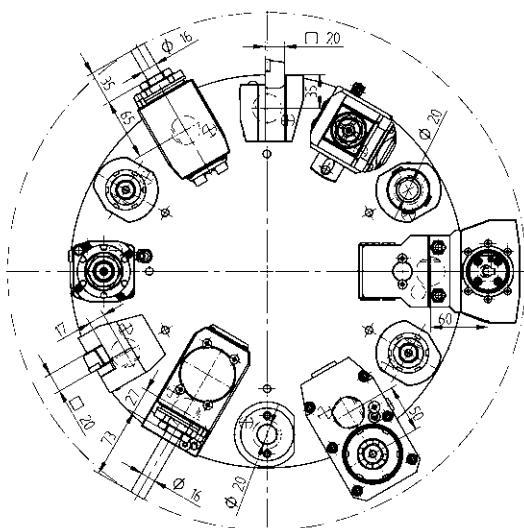

動力刀座 - 進階產品目錄

	直角式鑽/銑動力刀座		
ER-20 QF	420520011-30R 0067720011	1:2	EC
ER-20 QF	420520012-30R 0067720011	1:2	IC 80 bar
ER-25 QF	420525087-30R 0067725010	2:1	EC
ER-25 QF	420525088-30R 0067725010	2:1	IC 80 bar

	直角後縮式鑽/銑動力刀座		
ER 25	410516136-30 00675000801	2:1	EC
ER 25	410516137-30 00675000801	2:1	IC 80 bar

	直角式銑動力刀座 - 組合銑刀心軸, DIN6358		
Ø 16	410616021-30 00675000854	1:1	EC
Ø 22	410622011-30 00675000160	1:1	EC

動力刀座 - 進階產品目錄

	可調角度鑽/銑動力刀座		
ER 16	411010003-30 00675000902	1:1	EC
ER 16	411010004-30 00675000902	1:1	IC 80 bar
ER 11	411007016-30 00675000914	1:2	EC
ER 11	411007017-30 00675000914	1:2	IC 80 bar

	圓鋸開槽銑刀刀座		
14-2 型式	410900008-30 00675000460		2,615:1EC
	160016142 Ø 16		
	160022142 Ø 22		
	160027142 Ø 27		
	160015142 Ø 5/8"		
	160019142 Ø 3/4"		
	160023142 Ø 7/8"		
	160025142 Ø 1"		

	刨削刀座(內外徑通用)		
32 型式	414132000-30	1:1	EC

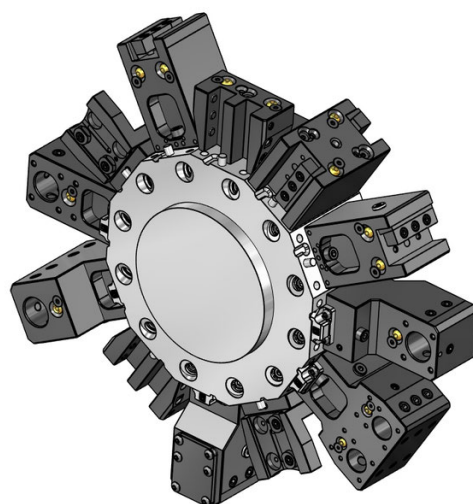
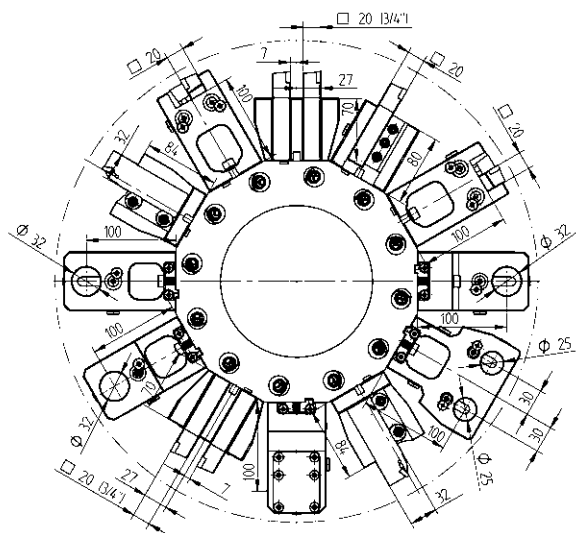

固定刀座 - 標準產品目錄



20(16) 方形刀柄軸向刀座, 右手刀, **C1**型式
48-C1-30x20

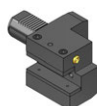

20(16) 方形刀柄軸向刀座, 左手刀, **C2**型式
48-C2-30x20



20(16) 方形刀柄軸向刀座, 右手反刀, **C3**型式
48-C3-30x20



20(16) 方形刀柄軸向刀座, 左手反刀, **C4**型式
48-C4-30x20

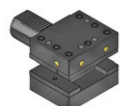

20(16) 方形刀柄刀座, **D1** 型式
48-D1-30x20



20(16) 方形刀柄刀座, 反刀, **D2** 型式
48-D2-30x20



20 外徑刀座, 左手刀
48-71932
R4Z410W

固定刀座 - 標準產品目錄



20 外徑刀座, 右手刀
48-72047
R4Z230W



20 外徑刀座, 正主軸及副主軸加工用
48-71216
R6Z410W



20 車端面刀座
48-105756



20 車端面刀座, **Trifix**®
48-109793



Ø 32 組合刀座, 通用, **LF=100**
48-71434
241132016 ER25
241132020 ER32



Ø 32 組合刀座, 通用, **Trifix**®, **LF=100**
48-96995
241132016 ER25
241132020 ER32

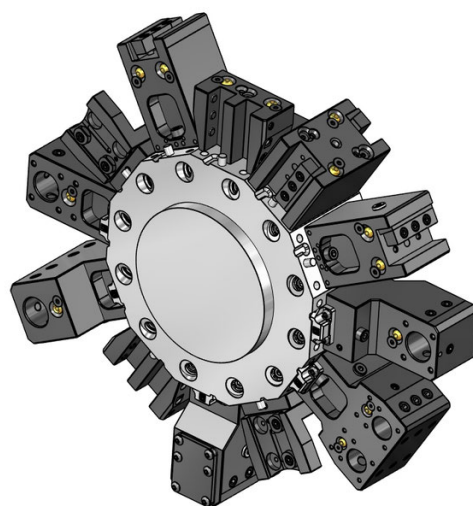
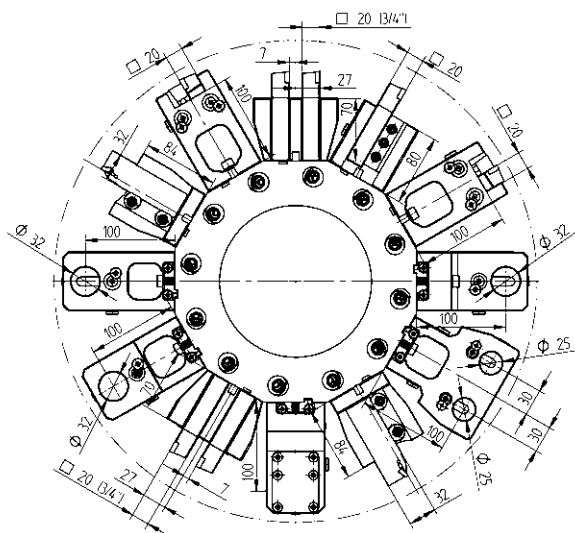

固定刀座 - 標準產品目錄



組合刀座, 後縮式, 左手刀, LF=100

Ø 32

48-71438

241132016 ER25

241132020 ER32



組合刀座, 後縮式, 左手刀, Trifix®, LF=100

Ø 32

48-97531

241132016 ER25

241132020 ER32



組合刀座, 後縮式, 右手刀, LF=100

Ø 32

48-71436

241132016 ER25

241132020 ER32



組合刀座, 後縮式, 右手刀, Trifix®, LF=100

Ø 32

48-97553

241132016 ER25

241132020 ER32



組合刀座, 正主軸及副主軸加工用, LF=100

Ø 32

48-88781

固定刀座 - 標準產品目錄



組合刀座, 正主軸及副主軸加工用, Trifix®, LF=100

Ø 32

48-97496



筒夾刀座, LF=100

ER 32

48-82824

IC 80 bar

107532000



筒夾刀座, Trifix®, LF=100

ER 32

48-100198

IC 80 bar

107532000



筒夾刀座, 正主軸及副主軸加工用, LF=100

ER 32

48-82847

IC 80 bar

107532000



筒夾刀座, 正主軸及副主軸加工用, Trifix®, LF=100

ER 32

48-100199

IC 80 bar

107532000

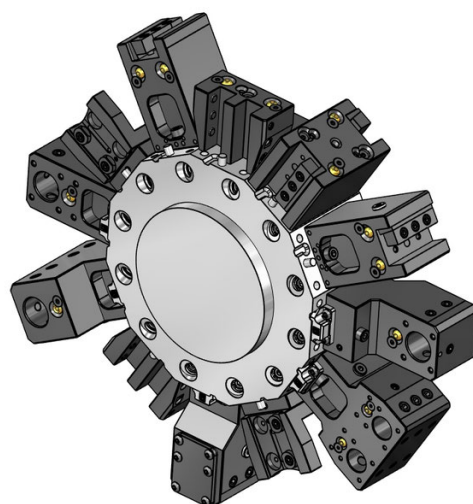
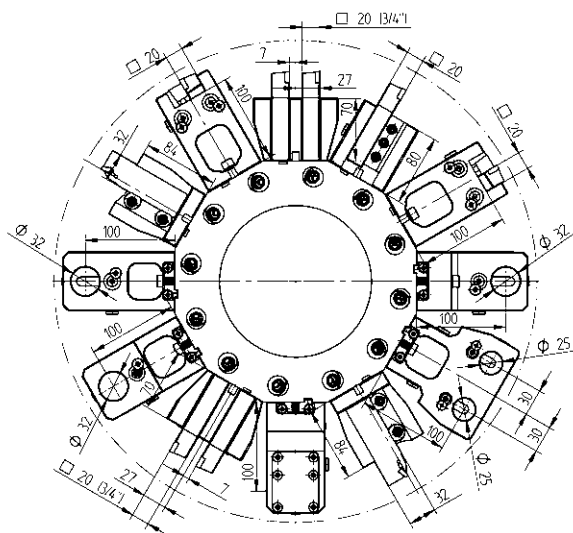

固定刀座 - 進階產品目錄

- 

20 外徑刀座, **HP-IC** 高壓中心出水 - **VDI** 雙面排齒
48-105977-HP IC 80 bar
- 

20 外徑刀座, 正主軸及副主軸加工用, **HP-IC**
48-71216-HP IC 80 bar
- 

20 (3/4") 外徑刀座, 2刀位, **Y-軸** - **VDI** 雙面排齒
48-84593
- 

20 (3/4") 外徑刀座, 正主軸及副主軸加工用, 2刀位, **Y-軸**
48-77395
442750W
- 

SH 26 切斷刀用刀座, 中心高可微調 - **VDI** 雙面排齒
48-98991
R4Z451W
- SH 32** 48-99017
R9Z450
- 

SH 26 切斷刀用刀座, 中心高可微調, 中心出水, **HP-IC** - **VDI** 雙面排齒
48-102630R IC 80 bar
343-810100R42
- SH 26** 48-102630L IC 80 bar
343-810100L42
- SH 32** 48-102632R IC 80 bar
- SH 32** 48-102632L IC 80 bar

固定刀座 - 進階產品目錄

- 

Ø 40 組合刀座, 通用, **Trifix®**, **LF=100** - **BMT**
48-99669
241140020 ER32
241140026 ER40
- 

Ø 32 搪刀刀座, 帶槽全周夾緊, **LF=100**
48-87088
- 

Ø 32 搪刀刀座, 帶槽全周夾緊, **Trifix®**, **LF=100**
48-97588
- 

Ø 40 搪刀刀座, 帶槽全周夾緊, **Trifix®**, **LF=100** - **BMT**
48-96994
- 

Ø 25 組合刀座, 通用, 2刀位, **Y-軸**, **LF=100**
48-79026
241125016 ER25
- 

Ø 25 組合刀座, 通用, 2刀位, **Y-軸**, **LF=100**, **Trifix®**
48-99635
241125016 ER25

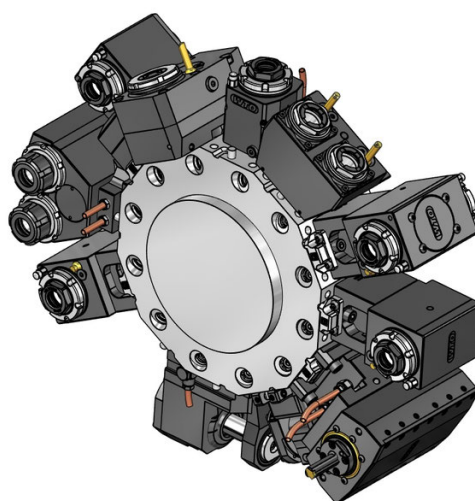
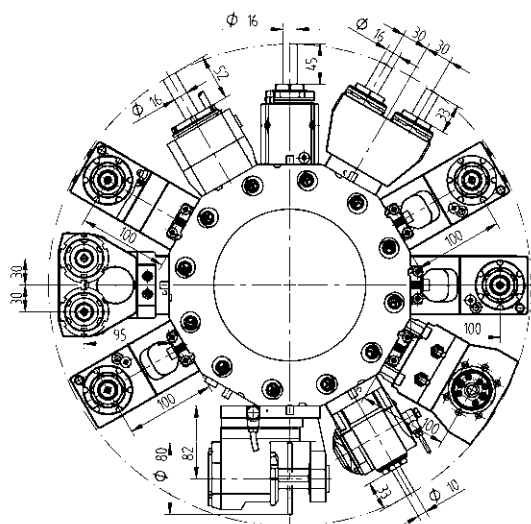

動力刀座 - QuickFlex® 產品目錄

-  **直結式鑽/銑動力刀座 (6000 RPM)**
- | | | | |
|-----------------|--|-----|-----------|
| ER-25 QF | 420125010-30L
440441W | 1:1 | EC |
| |  0067725010 | | |
| ER-25 QF | 420125019-30L | 1:1 | IC 80 bar |
| |  0067725010 | | |

-  **直結式鑽/銑動力刀座 (12000 RPM)**
- | | | | |
|-----------------|--|-----|-----------|
| ER-25 QF | 420125014-30L | 1:1 | EC |
| |  0067725010 | | |
| ER-25 QF | 420125015-30L | 1:1 | IC 80 bar |
| |  0067725010 | | |



-  **直角式鑽/銑動力刀座, Trifix®, (6000 RPM)**
- | | | | |
|-----------------|--|-----|-----------|
| ER-25 QF | 420525055-30L | 1:1 | EC |
| |  0067725010 | | |
| ER-25 QF | 420525056-30L | 1:1 | IC 80 bar |
| |  0067725010 | | |

-  **直角式鑽/銑動力刀座, Trifix®, (12000 RPM)**
- | | | | |
|-----------------|--|-----|-----------|
| ER-25 QF | 420525057-30L | 1:1 | EC |
| |  0067725010 | | |
| ER-25 QF | 420525058-30L | 1:1 | IC 80 bar |
| |  0067725010 | | |

動力刀座 - QuickFlex® 產品目錄

-  **直角式鑽/銑動力刀座, Trifix®, (6000 RPM)**
- | | | | |
|-----------------|--|-----|-----------|
| ER-25 QF | 420525055-30R | 1:1 | EC |
| |  0067725010 | | |
| ER-25 QF | 420525056-30R | 1:1 | IC 80 bar |
| |  0067725010 | | |

-  **直角式鑽/銑動力刀座, Trifix®, (12000 RPM)**
- | | | | |
|-----------------|--|-----|-----------|
| ER-25 QF | 420525057-30R | 1:1 | EC |
| |  0067725010 | | |
| ER-25 QF | 420525058-30R | 1:1 | IC 80 bar |
| |  0067725010 | | |

-  **直角後縮式鑽/銑動力刀座, Trifix®, (6000 RPM)**
- | | | | |
|-----------------|--|-----|-----------|
| ER-25 QF | 420525089-30L | 1:1 | EC |
| |  0067725010 | | |
| ER-25 QF | 420525090-30L | 1:1 | IC 80 bar |
| |  0067725010 | | |

-  **直角後縮式鑽/銑動力刀座, Trifix®, (12000 RPM)**
- | | | | |
|-----------------|--|-----|-----------|
| ER-25 QF | 420525060-30L | 1:1 | EC |
| |  0067725010 | | |
| ER-25 QF | 420525061-30L | 1:1 | IC 80 bar |
| |  0067725010 | | |

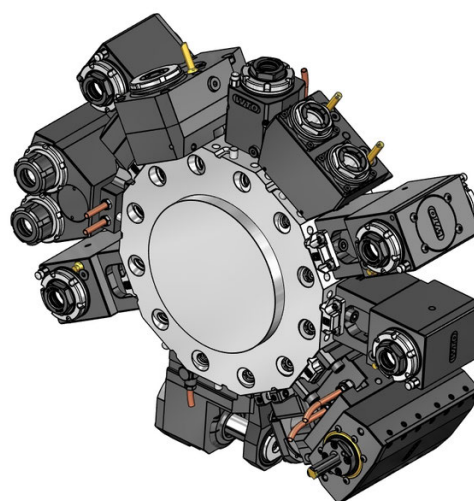
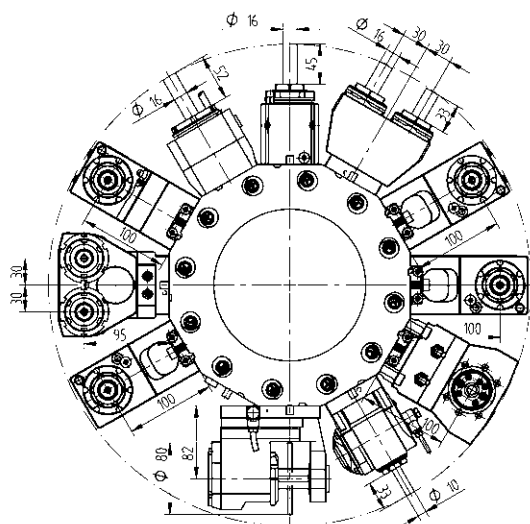

動力刀座 - QuickFlex® 產品目錄

動力刀座 - 進階產品目錄



直角後縮式鑽/銑動力刀座, Trifix®, (6000 RPM)

ER-25 QF 420525089-30R 1:1 EC
0067725010

ER-25 QF 420525090-30R 1:1 IC 80 bar
0067725010



直角後縮式鑽/銑動力刀座, Trifix®, (12000 RPM)

ER-25 QF 420525060-30R 1:1 EC
0067725010

ER-25 QF 420525061-30R 1:1 IC 80 bar
0067725010



直角式鑽/銑動力刀座, 正主軸及副主軸加工用, Trifix®, (6000 RPM)

ER-25 QF 420525086-30 1:1 EC
0067725010



直角式鑽/銑動力刀座, 正主軸及副主軸加工用, Trifix®, (12000 RPM)

ER-25 QF 420525095-30 1:1 EC
0067725010



直結式鑽/銑動力刀座 - BMT

ER-32 QF 420132010-30 1:1 EC
0067732000

ER-32 QF 420132011-30 1:1 IC 80 bar
0067732000



直結式銑刀座

Ø 16 410216014-30 1:1 EC
00675000854

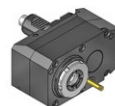

直結偏位式鑽/銑動力刀座

ER 25 410116058-30 1:1 EC
00675000801

ER 25 410116057-30 1:1 IC 80 bar
00675000801

ER 20 410113010-30 1:2 EC
00675000591

ER 20 410113009-30 1:2 IC 80 bar
00675000591

ER 25 410116059-30 2:1 EC
00675000801

ER 25 410116060-30 2:1 IC 80 bar
00675000801

ER 32 410120027-30 2:1 EC
00675000592

ER 32 410120032-30 2:1 IC 80 bar
00675000592

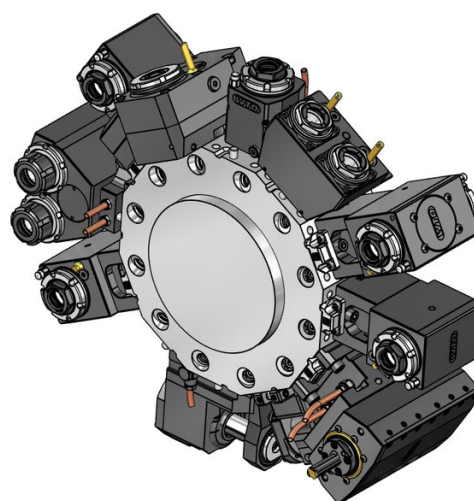
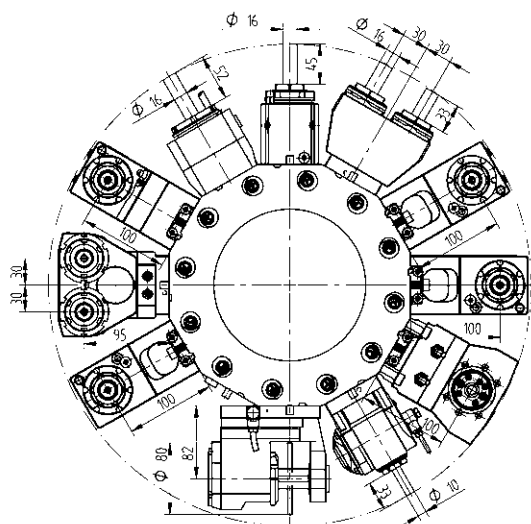

動力刀座 - 進階產品目錄

動力刀座 - 進階產品目錄



直結偏位式鑽/銑動力刀座 - VDI 雙面排齒

- ER 16 410410002-30 1:3 EC
00675000937
- ER 16 410410001-30 1:3 IC 80 bar
00675000937



直角後縮式鑽/銑動力刀座

- ER 32 410520013-30 2:1 EC
00675000592
- ER 32 410520014-30 2:1 IC 80 bar
00675000592



直角式鑽/銑動力刀座

- ER-20 QF 420520013-30 1:2 EC
0067720011
- ER-20 QF 420520014-30 1:2 IC 80 bar
0067720011
- ER 16 410810012-30 1:3 EC
00675000841
- ER 16 410810013-30 1:3 IC 80 bar
00675000841
- ER-25 QF 420525096-30 2:1 EC
0067725010
- ER-25 QF 420525097-30 2:1 IC 80 bar
0067725010

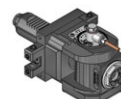

可調角度鑽/銑動力刀座

- ER 16 411010015-30 1:1 EC
00675000902
- ER 16 411010016-30 1:1 IC 80 bar
00675000902
- ER 11 411007018-30 1:2 EC
00675000914
- ER 11 411007019-30 1:2 IC 80 bar
00675000914



直角式鑽/銑動力刀座, Trifix®

- ER-20 QF 420520015-30L 1:2 EC
0067720011
- ER-20 QF 420520016-30L 1:2 IC 80 bar
0067720011



圓鋸開槽銑刀刀座

- 14-2 型式 410900015-30 2,615:1EC
00675000460
- 160016142 Ø 16
- 160022142 Ø 22
- 160027142 Ø 27
- 160015142 Ø 5/8"
- 160019142 Ø 3/4"
- 160023142 Ø 7/8"
- 160025142 Ø 1"

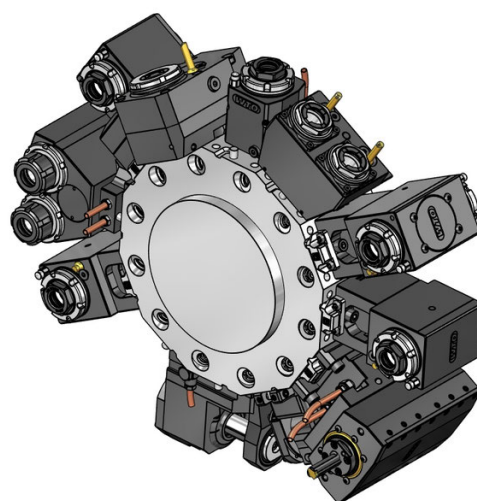
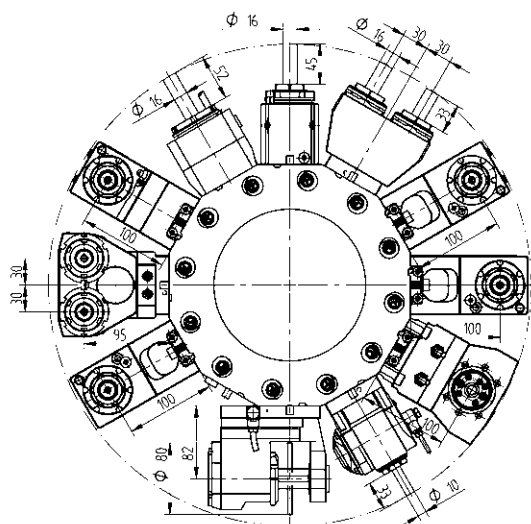

動力刀座 - 進階產品目錄

動力刀座 - 進階產品目錄

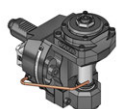

滾齒刀座, Trifix®

- | | | | |
|----------------|------------------|-----|----|
| 15-2 型式 | 410900025-30 | 1:1 | EC |
| | 00675001015 | | |
| | 160008152 Ø 8 | | |
| | 160010152 Ø 10 | | |
| | 160013152 Ø 13 | | |
| | 160016152 Ø 16 | | |
| | 160022152 Ø 22 | | |
| | 160015152 Ø 5/8" | | |
| | 160019152 Ø 3/4" | | |
| | 110587 | | |



二軸直角鑽/銑動力刀座, 正主軸及副主軸加工用, Y-軸

- | | | | |
|--------------|--------------|-----|----|
| ER 25 | 413502009-30 | 1:1 | EC |
| | 00675000915 | | |



刨削刀座 (內外徑通用), Trifix® - BMT

- | | | | |
|--------------|---------------|-----|----|
| 32 型式 | 414532001-30L | 1:1 | EC |
|--------------|---------------|-----|----|



刨削刀座 (內外徑通用), Trifix® - BMT

- | | | | |
|--------------|---------------|-----|----|
| 32 型式 | 414532001-30R | 1:1 | EC |
|--------------|---------------|-----|----|



直結式鑽/銑刀座, 2刀位, Y-軸

- | | | | |
|--------------|--------------|-------|-----------|
| ER 25 | 413002008-30 | 1:1,5 | EC |
| | 00675000930 | | |
| ER 25 | 413002009-30 | 1:1,5 | IC 80 bar |
| | 00675000930 | | |



二軸直角鑽/銑動力刀座, Y-軸

- | | | | |
|--------------|--------------|-----|-----------|
| ER 25 | 413502000-30 | 1:1 | EC |
| | 00675000915 | | |
| ER 25 | 413502004-30 | 1:1 | IC 80 bar |
| | 00675000915 | | |

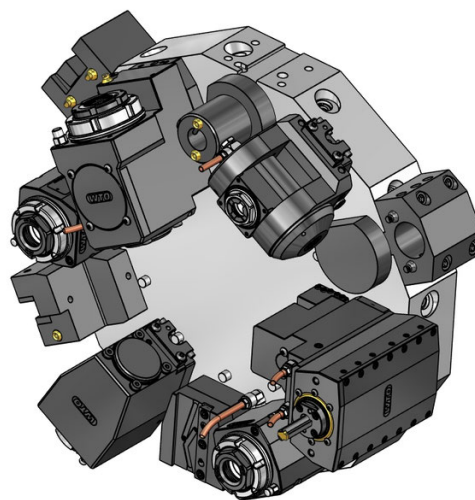
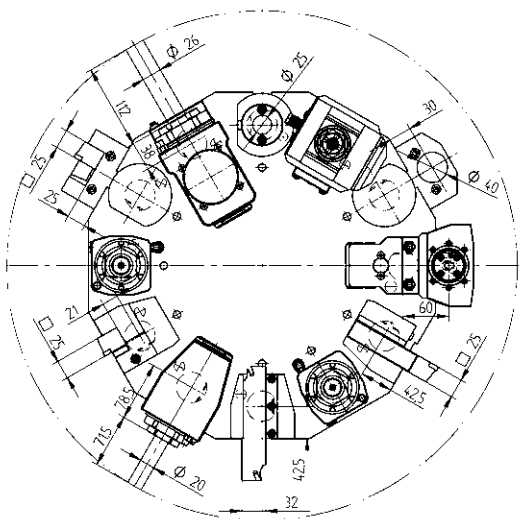

固定刀座 - 標準產品目錄



25 車端面刀座
48-PU2-25-25



組合刀座
 Ø 20 48-PU1-25-20 IC 80 bar
 Ø 25 48-PU1-25-25 IC 80 bar
 Ø 32 48-PU1-25-32 IC 80 bar
 Ø 40 48-PU1-25-40 IC 80 bar
 Ø 50 48-PU1-25-50 IC 80 bar



VDI 40 VDI接柄, 右手刀
48-99856



25(20) 徑向右手方形刀座, 短型, **B1**型式
48-B1-40x25

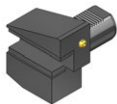

25(20) 徑向右手方形刀座, 反刀, 短型, **B3**型式
48-B3-40x25



25(20) 徑向右手方形刀座, 長型, **B5**型式
48-B5-40x25



25(20) 徑向右手方形刀座, 反刀, 長型, **B7**型式
48-B7-40x25

固定刀座 - 標準產品目錄



25 徑向方形刀座, **HP-IC - VDI** 雙面排齒
48-105989R-HP IC 80 bar
25 48-102790L-HP IC 80 bar

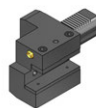

25(20) 方形刀柄軸向刀座, 右手刀, **C1**型式
48-C1-40x25

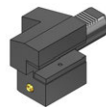

25(20) 方形刀柄軸向刀座, 右手反刀, **C3**型式
48-C3-40x25



SH 26 切斷刀用刀座, 中心高可微調, 右手刀
48-AR-40x26
SH 32 48-AR-40x32



SH 26 切斷刀用刀座, 中心高可微調, 右手反刀
48-ARU-40x26



SH 32 切斷刀用刀座, 中心高可微調, 中心出水, **HP-IC**
48-102690R IC 80 bar
SH 32 48-102690L IC 80 bar

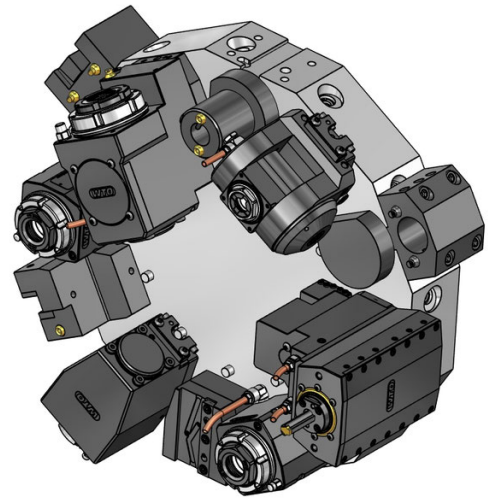
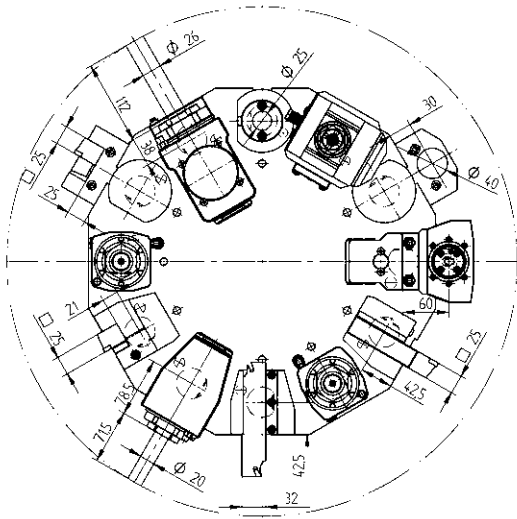

固定刀座 - 標準產品目錄



捨棄式刀片鑽頭刀座, 中心出水, E1型式

- Ø 16 48-E1-40x16
- Ø 20 48-E1-40x20
- Ø 25 48-E1-40x25
- Ø 32 48-E1-40x32
- Ø 40 48-E1-40x40



擔刀刀座, 中心出水, E2型式

- Ø 8 48-E2-40x8
- Ø 10 48-E2-40x10
- Ø 12 48-E2-40x12
- Ø 16 48-E2-40x16
- Ø 20 48-E2-40x20
- Ø 25 48-E2-40x25
- Ø 30 48-E2-40x30
- Ø 32 48-E2-40x32
- Ø 40 48-E2-40x40



ER筒夾刀座, DIN 6499B, 中心出水, E4型式

- ER 25 48-E4-40x25
107525000
- ER 32 48-E4-40x32
107532000
- ER 40 48-E4-40x40
107540000

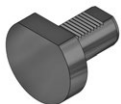

防污塞, 鋼材, Z2型式
鋼材 48-Z2-40-S

動力刀座 - QuickFlex® 產品目錄



直結式鑽/銑動力刀座

- ER-32 QF 420132077-40R 1:1 EC
442145W, T32595
0067732000
- ER-32 QF 420132078-40R 1:1 IC 80 bar
0067732000



直角式鑽/銑動力刀座

- ER-32 QF 420532042-40R 1:1 EC
442275W
0067732000
- ER-32 QF 420532043-40R 1:1 IC 80 bar
0067732000



直角後縮式鑽/銑動力刀座

- ER-32 QF 420532037-40R 1:1 EC
0067732000
- ER-32 QF 420532038-40R 1:1 IC 80 bar
0067732000

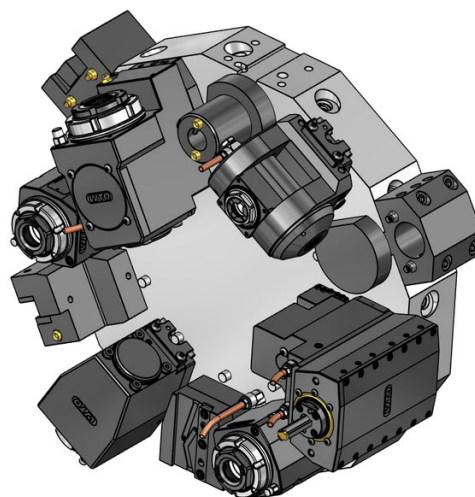
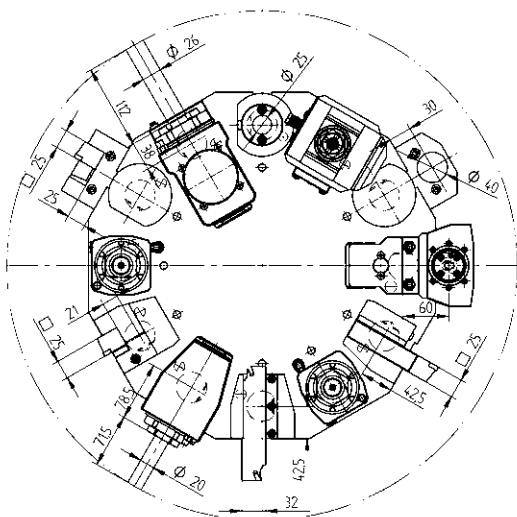

動力刀座 - 進階產品目錄



直結式銑刀座 - 組合銑刀心軸, DIN6358

Ø 22 410222025-40 1:1 EC
 00675000479



直結偏位式鑽/銑動力刀座

ER-32 QF 420132054-40R 1:1 EC
 0067732000
 ER-32 QF 420132055-40R 1:1 IC 80 bar
 0067732000
 ER-25 QF 420125024-40R 1:2 EC
 0067725001
 ER-25 QF 420125025-40R 1:2 IC 80 bar
 0067725001
 ER-32 QF 420132056-40R 2:1 EC
 0067732000
 ER-32 QF 420132057-40R 2:1 IC 80 bar
 0067732000



直結偏位式鑽/銑動力刀座 - VDI 雙面排齒

ER 16 410410001-40 1:3 EC
 00675000937
 ER 16 410410002-40 1:3 IC 80 bar
 00675000937

動力刀座 - 進階產品目錄



直角式鑽/銑動力刀座

ER-25 QF 420525058-40 1:2 EC
 0067725001
 ER-25 QF 420525059-40 1:2 IC 80 bar
 0067725001



直角後縮式鑽/銑動力刀座

ER-40 QF 420540027-40R 2:1 EC
 0067740000
 ER-40 QF 420540028-40R 2:1 IC 80 bar
 0067740000



可調角度鑽/銑動力刀座

ER 20 411013019-40 1:1 EC
 00675000928
 ER 20 411013026-40 1:1 IC 80 bar
 00675000928
 ER 25 411016006-40 1:1 EC
 00675000934
 ER 25 411016024-40 1:1 IC 80 bar
 00675000934
 ER 16 411010012-40 1:2 EC
 00675000936
 ER 16 411010013-40 1:2 IC 80 bar
 00675000936

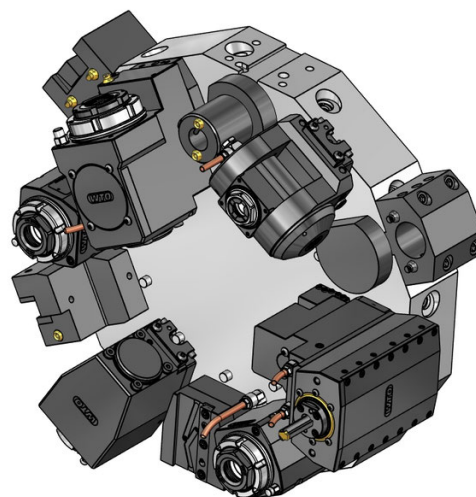
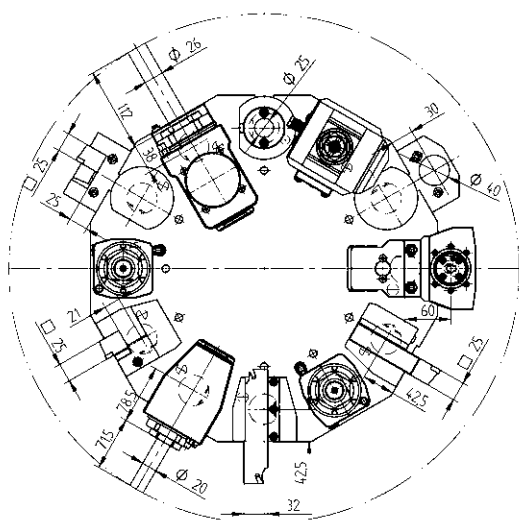

動力刀座 - 進階產品目錄



橫向圓鋸開槽刀座

14-2 型式 411500009-40 2,727:1EC

00675000460

 160016142 Ø 16

 160022142 Ø 22

 160027142 Ø 27

 160015142 Ø 5/8"

 160019142 Ø 3/4"

 160023142 Ø 7/8"

 160025142 Ø 1"



刨削刀座(內外徑通用)

32 型式 414132002-40 1:1 EC

52 型式 414152000-40 1:1 EC

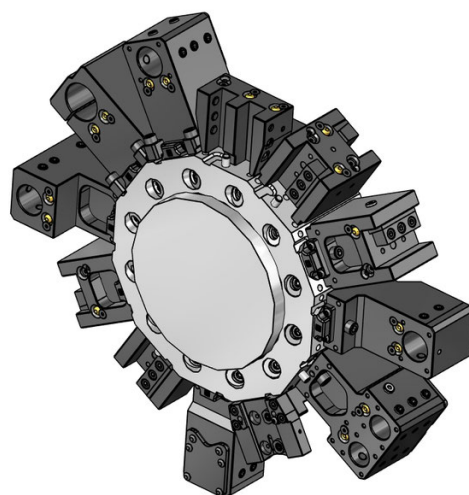
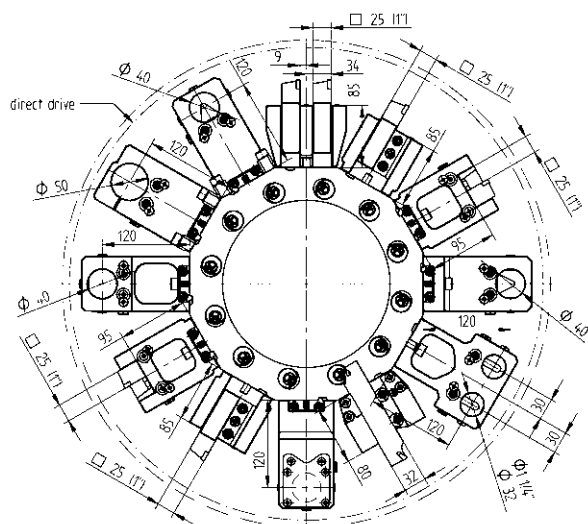

固定刀座 - 標準產品目錄

 外徑刀座 - VDI 雙面排齒
25 48-85982

 外徑刀座, 正主軸及副主軸加工用
25 48-59098
442340

 車端面刀座
25 48-87589

 車端面刀座, Trifix®
25 48-96528

 組合刀座, 通用, LF=120
Ø 40 48-64021
241140020 ER32

 組合刀座, 通用, Trifix®, LF=120
Ø 40 48-96530
T12138
241140020 ER32
241140026 ER40

固定刀座 - 標準產品目錄

 組合刀座, 後縮式 - VDI 雙面排齒, LF=120
Ø 40 48-110591
241140020 ER32

 組合刀座, 後縮式, 左手刀, Trifix®, LF=120
Ø 40 48-110694
241140026 ER40
241140020 ER32

 組合刀座, 後縮式, 右手刀, Trifix®, LF=120
Ø 40 48-97044
241140020 ER32
241140026 ER40

 組合刀座, 正主軸及副主軸加工用, LF=120
Ø 40 48-97388

 組合刀座, 正主軸及副主軸加工用, Trifix®, LF=120
Ø 40 48-97036
T12139

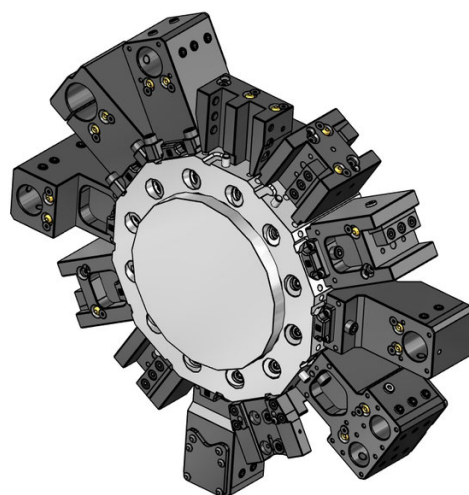
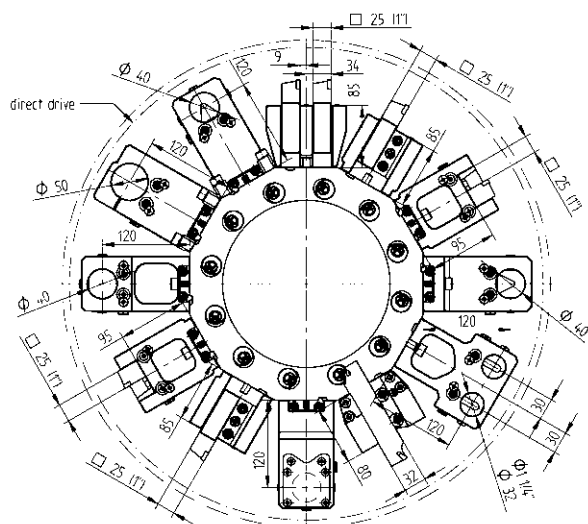

固定刀座 - 標準產品目錄

- 

ER 32 筒夾刀座, 正主軸及副主軸加工用, **LF=120**
 48-66629 IC 80 bar
 107532000
- 

ER 40 筒夾刀座, 正主軸及副主軸加工用, **LF=120**
 48-97389 IC 80 bar
 107540000
- 

ER 32 筒夾刀座, 正主軸及副主軸加工用, **Trifix®**, **LF=120**
 48-97051 IC 80 bar
 107532000
- 

ER 40 筒夾刀座, 正主軸及副主軸加工用, **Trifix®**, **LF=120**
 48-97052 IC 80 bar
 107540000
- 

鋼材 防污塞, 鋼材, **Z2**型式
 48-Z2-40-S

固定刀座 - 進階產品目錄

- 

25 外徑刀座, **HP-IC** 高壓中心出水 - **VDI** 雙面排齒
 48-105986-HP IC 80 bar
- 

25 外徑刀座, 正主軸及副主軸加工用, **HP-IC**
 48-59098-HP
- 

25(1") 外徑刀座, **2**刀位, **Y**-軸 - **VDI** 雙面排齒
 48-86080
- 

25(1") 外徑刀座, 正主軸及副主軸加工用, **2**刀位, **Y**-軸
 48-89779
- 

SH 32 切斷刀用刀座, 中心高可微調 - **VDI** 雙面排齒
 48-98963
 R9Z455, T00460, T00461
- 

SH 32 切斷刀用刀座, 中心高可微調, 中心出水, **HP-IC** - **VDI** 雙面排齒
 48-102643R IC 80 bar
 48-102643L IC 80 bar

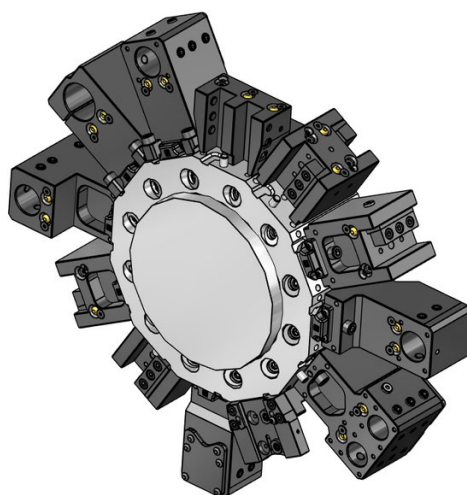
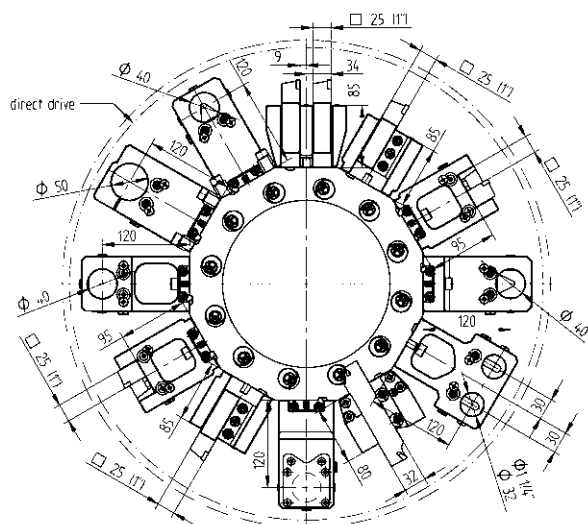

固定刀座 - 進階產品目錄



切斷刀用刀座, 中心高可微調, 長型, 中心出水, **HP-IC - VDI 雙面排齒**

- SH 32** 48-99091R IC 80 bar
- 343-810100R8
- SH 32** 48-99091L IC 80 bar
- 343-810100L8



組合刀座, 通用, **Trifix®, LF=120 - BMT**

- Ø 40** 48-97097
- 241140020 ER32
- 241140026 ER40



組合刀座, 後縮式, 左面, **Trifix®, LF=120 - BMT**

- Ø 40** 48-111059
- 241140020 ER32
- 241140026 ER40



組合刀座, 後縮式, 右面, **Trifix®, LF=120 - BMT**

- Ø 40** 48-97164
- 241140020 ER32
- 241140026 ER40



組合刀座, 正主軸及副主軸加工用, **Trifix®, LF=120 - BMT**

- Ø 40** 48-97105

固定刀座 - 進階產品目錄



擔刀刀座, 帶槽全周夾緊, **Trifix®, LF=120 - BMT**

- Ø 50** 48-97257



組合刀座, 通用, 2刀位, Y-軸, **LF=120**

- Ø 32** 48-86296
- 241132016 ER25
- 241132020 ER32



組合刀座, 通用, 2刀位, Y-軸, **LF=120, Trifix®**

- Ø 32** 48-96531
- 241132016 ER25
- 241132020 ER32

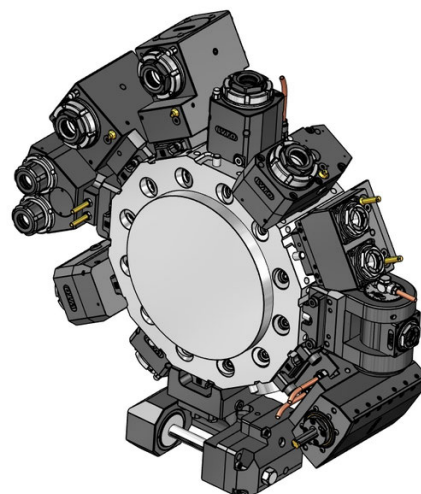
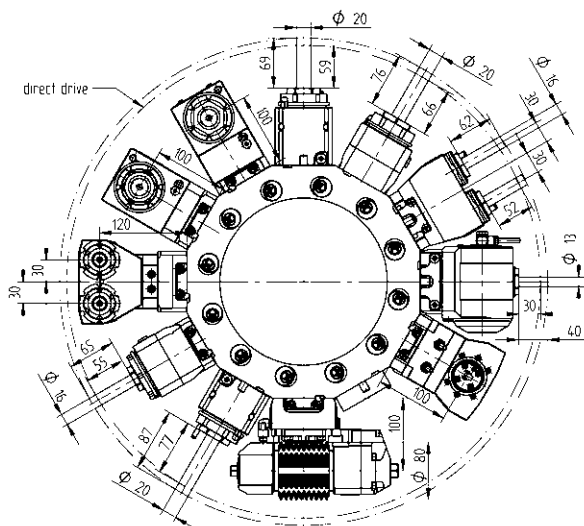

動力刀座 - QuickFlex® 產品目錄

- 直結式鑽/銑動力刀座 (6000 RPM)**
- | | | | |
|-----------------|---------------|-----|-----------|
| ER-32 QF | 420132077-40L | 1:1 | EC |
| | 0067732000 | | |
| ER-32 QF | 420132078-40L | 1:1 | IC 80 bar |
| | 0067732000 | | |

- 直結式鑽/銑動力刀座 (10000 RPM)**
- | | | | |
|-----------------|---------------|-----|-----------|
| ER-32 QF | 420132069-40L | 1:1 | EC |
| | 442141W | | |
| | 0067732000 | | |
| ER-32 QF | 420132070-40L | 1:1 | IC 80 bar |
| | 0067732000 | | |

- 直角式鑽/銑動力刀座, Trifix®, LF=100, (6000 RPM)**
- | | | | |
|-----------------|---------------|-----|-----------|
| ER-32 QF | 420532015-40L | 1:1 | EC |
| | 0067732000 | | |
| ER-32 QF | 420532016-40L | 1:1 | IC 80 bar |
| | 0067732000 | | |

- 直角式鑽/銑動力刀座, Trifix®, LF=100, (10000 RPM)**
- | | | | |
|-----------------|---------------|-----|-----------|
| ER-32 QF | 420532024-40L | 1:1 | EC |
| | 0067732000 | | |
| ER-32 QF | 420532025-40L | 1:1 | IC 80 bar |
| | 0067732000 | | |

動力刀座 - QuickFlex® 產品目錄

- 直角式鑽/銑動力刀座, Trifix®, LF=100, (6000 RPM)**
- | | | | |
|-----------------|---------------|-----|-----------|
| ER-32 QF | 420532015-40R | 1:1 | EC |
| | 0067732000 | | |
| ER-32 QF | 420532016-40R | 1:1 | IC 80 bar |
| | 0067732000 | | |

- 直角式鑽/銑動力刀座, Trifix®, LF=100, (10000 RPM)**
- | | | | |
|-----------------|---------------|-----|-----------|
| ER-32 QF | 420532024-40R | 1:1 | EC |
| | 0067732000 | | |
| ER-32 QF | 420532025-40R | 1:1 | IC 80 bar |
| | 0067732000 | | |

- 直角後縮式鑽/銑動力刀座, Trifix®, LF=100, (6000 RPM)**
- | | | | |
|-----------------|---------------|-----|-----------|
| ER-32 QF | 420532032-40L | 1:1 | EC |
| | 0067732000 | | |
| ER-32 QF | 420532033-40L | 1:1 | IC 80 bar |
| | 0067732000 | | |

- 直角後縮式鑽/銑動力刀座, Trifix®, LF=100, (10000 RPM)**
- | | | | |
|-----------------|---------------|-----|-----------|
| ER-32 QF | 420532081-40L | 1:1 | EC |
| | 0067732000 | | |
| ER-32 QF | 420532082-40L | 1:1 | IC 80 bar |
| | 0067732000 | | |

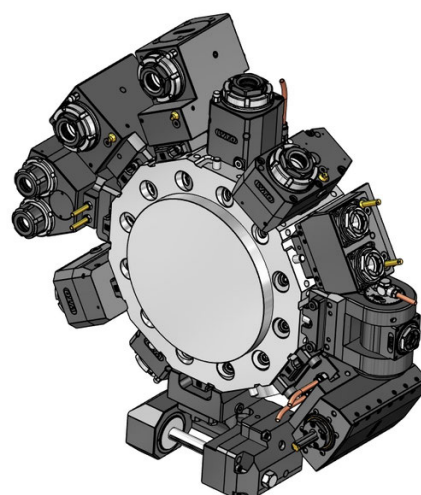
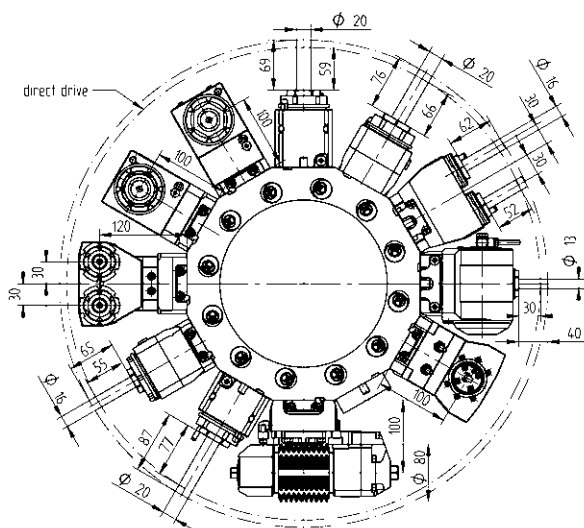

動力刀座 - QuickFlex® 產品目錄



直角後縮式鑽/銑動力刀座, Trifix®, LF=100, (6000 RPM)

- | | | | |
|-----------------|-----------------------------|-----|-----------|
| ER-32 QF | 420532032-40R
0067732000 | 1:1 | EC |
| ER-32 QF | 420532033-40R
0067732000 | 1:1 | IC 80 bar |



直角後縮式鑽/銑動力刀座, Trifix®, LF=100, (10000 RPM)

- | | | | |
|-----------------|-----------------------------|-----|-----------|
| ER-32 QF | 420532081-40R
0067732000 | 1:1 | EC |
| ER-32 QF | 420532082-40R
0067732000 | 1:1 | IC 80 bar |



直角式鑽/銑動力刀座, 正主軸及副主軸加工用, Trifix®, LF=100, (6000 RPM)

- | | | | |
|-----------------|----------------------------|-----|----|
| ER-32 QF | 420532017-40
0067732000 | 1:1 | EC |
|-----------------|----------------------------|-----|----|



直角式鑽/銑動力刀座, 正主軸及副主軸加工用, Trifix®, LF=100, (10000 RPM)

- | | | | |
|-----------------|----------------------------|-----|----|
| ER-32 QF | 420532133-40
0067732000 | 1:1 | EC |
|-----------------|----------------------------|-----|----|

動力刀座 - 進階產品目錄



直結式鑽/銑動力刀座 - BMT

- | | | | |
|-----------------|----------------------------|-----|-----------|
| ER-40 QF | 420140010-40
0067740000 | 1:1 | EC |
| ER-40 QF | 420140011-40
0067740000 | 1:1 | IC 80 bar |



直結式銑刀座 - 組合銑刀心軸, DIN6358

- | | | | |
|-------------|-----------------------------|-----|----|
| Ø 22 | 410222025-40
00675000479 | 1:1 | EC |
|-------------|-----------------------------|-----|----|

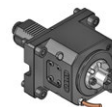

直結式銑刀座 - BMT - 組合銑刀心軸, DIN6358

- | | | | |
|-------------|-----------------------------|-----|----|
| Ø 22 | 410222022-40
00675000479 | 1:1 | EC |
| Ø 27 | 410227010-40
00675000480 | 1:1 | EC |

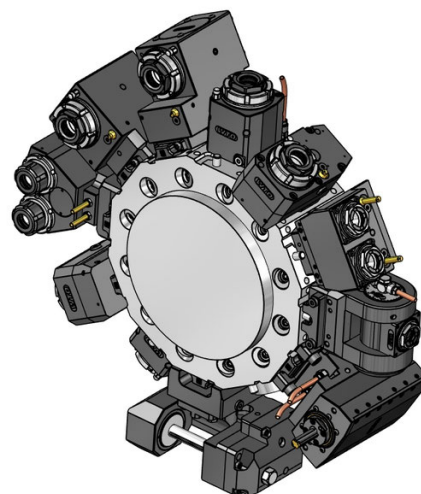
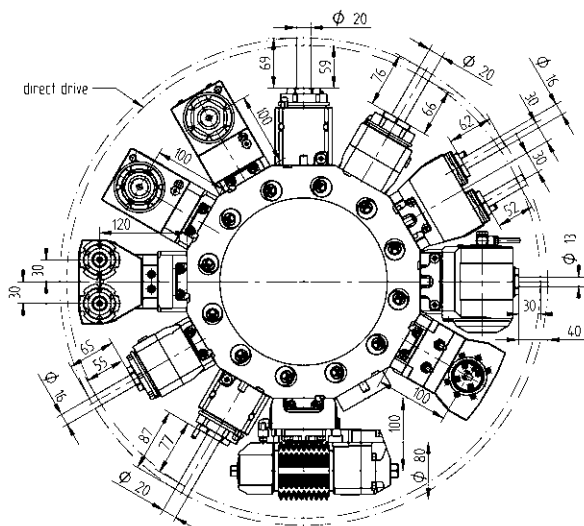

動力刀座 - 進階產品目錄



直結偏位式鑽/銑動力刀座

ER-32 QF	420132054-40L 0067732000	1:1	EC
ER-32 QF	420132055-40L 0067732000	1:1	IC 80 bar
ER-25 QF	420125024-40L 0067725001	1:2	EC
ER-25 QF	420125025-40L 0067725001	1:2	IC 80 bar
ER-32 QF	420132056-40L 0067732000	2:1	EC
ER-32 QF	420132057-40L 0067732000	2:1	IC 80 bar



直結偏位式鑽/銑動力刀座, Trifix®

ER-25 QF	420125039-40L 0067725001	1:2	EC
ER-25 QF	420125038-40L 0067725001	1:2	IC 80 bar



直結偏位式鑽/銑動力刀座, Trifix®

ER-25 QF	420125039-40R 0067725001	1:2	EC
ER-25 QF	420125038-40R 0067725001	1:2	IC 80 bar

動力刀座 - 進階產品目錄



直角式鑽/銑動力刀座, Trifix®, LF=100 - BMT

ER-32 QF	420532028-40L 0067732000	1:1	EC
ER-32 QF	420532029-40L 0067732000	1:1	IC 80 bar
ER-40 QF	420540010-40L 0067740000	2:1	EC
ER-40 QF	420540011-40L 0067740000	2:1	IC 80 bar



直角式鑽/銑動力刀座, Trifix®, LF=100 - BMT

ER-32 QF	420532028-40R 0067732000	1:1	EC
ER-32 QF	420532029-40R 0067732000	1:1	IC 80 bar
ER-40 QF	420540010-40R 0067740000	2:1	EC
ER-40 QF	420540011-40R 0067740000	2:1	IC 80 bar



直角式鑽/銑動力刀座, Trifix®, LF=100

ER-25 QF	420525017-40L 0067725000	1:2	EC
ER-25 QF	420525018-40L 0067725000	1:2	IC 80 bar

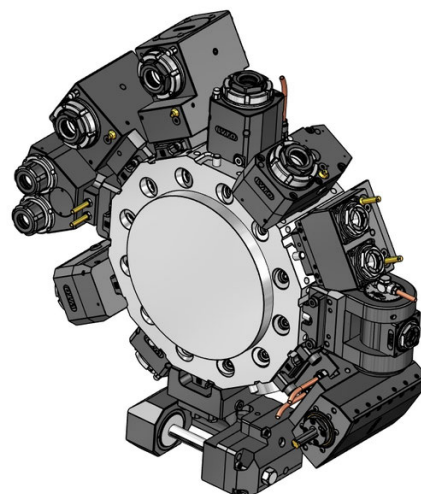
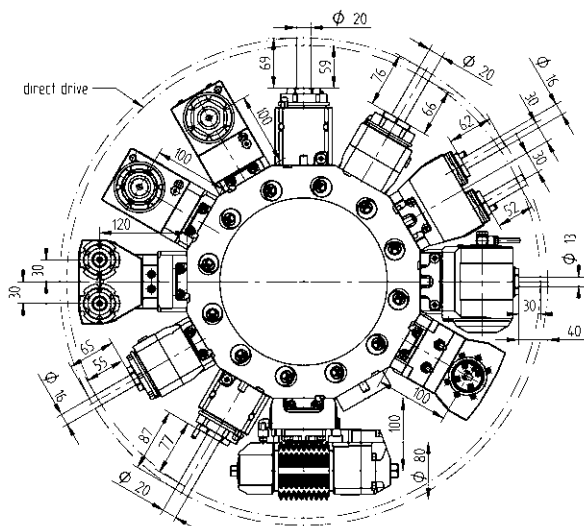

動力刀座 - 進階產品目錄



直角式鑽/銑動力刀座, Trifix®, LF=100

- ER-25 QF 420525017-40R 1:2 EC
0067725000
- ER-25 QF 420525018-40R 1:2 IC 80 bar
0067725000



直角式鑽/銑動力刀座, 正主軸及副主軸加工用, Trifix®, LF=100 - BMT

- ER-40 QF 420540017-40 1:1 EC
0067740000

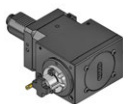

直角式銑動力刀座 - VDI 雙面排齒, LF=100

- Ø 22 410622028-40 2:1 EC
00675000160
- Ø 27 410627015-40 2:1 EC
00675000211

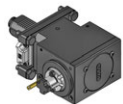

直角式銑動力刀座, Trifix®, LF=100 - BMT

- Ø 22 410622031-40L 2:1 EC
00675000160
- Ø 27 410627016-40L 2:1 EC
00675000211

動力刀座 - 進階產品目錄



直角式銑動力刀座, Trifix®, LF=100 - BMT

- Ø 22 410622031-40R 2:1 EC
00675000160
- Ø 27 410627016-40R 2:1 EC
00675000211



可調角度鑽/銑動力刀座

- ER 20 411013018-40 1:1 EC
00675000928
- ER 20 411013029-40 1:1 IC 80 bar
00675000928
- ER 16 411010030-40 1:2 EC
00675000936
- ER 16 411010031-40 1:2 IC 80 bar
00675000936



圓鋸開槽銑刀刀座

- 14-2 型式 410900013-40 2,615:1EC
00675000460
- 160016142 Ø 16
- 160022142 Ø 22
- 160027142 Ø 27
- 160015142 Ø 5/8"
- 160019142 Ø 3/4"
- 160023142 Ø 7/8"
- 160025142 Ø 1"

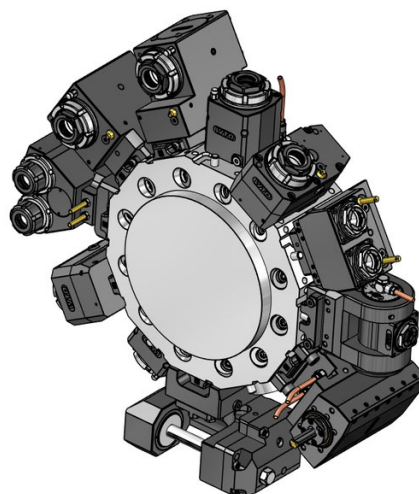
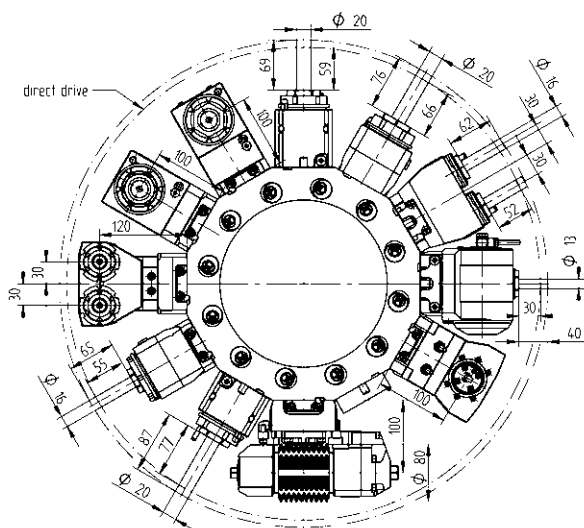

動力刀座 - 進階產品目錄



滾齒刀座, Trifix®

16-1 型式	411500041-40L	1:1	EC
16-1 型式	411500037-40L	2:1	EC
	00675000926		
	160016161 Ø 16		
	160022161 Ø 22		
	160027161 Ø 27		
	160015161 Ø 5/8"		
	160019161 Ø 3/4"		
	160025161 Ø 1"		
	160031161 Ø 1 1/4"		
	110587		



滾齒刀座, Trifix®

16-1 型式	411500041-40R	1:1	EC
16-1 型式	411500037-40R	2:1	EC
	110587		
	160031161 Ø 1 1/4"		
	160022161 Ø 22		
	160016161 Ø 16		
	00675000926		
	160027161 Ø 27		
	160025161 Ø 1"		
	160019161 Ø 3/4"		
	160015161 Ø 5/8"		

動力刀座 - 進階產品目錄

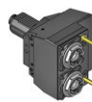

直結式鑽/銑刀座, 2刀位, Y-軸

ER 25	413002034-40	1:1,5	EC
	00675000930		
ER 25	413002035-40	1:1,5	IC 80 bar
	00675000930		

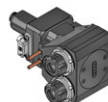

二軸直角鑽/銑動力刀座, Y-軸, LF=120, Trifix®

ER 25	413502024-40L	1:1	EC
	00675000915		
ER 25	413502025-40L	1:1	IC 80 bar
	00675000915		



二軸直角鑽/銑動力刀座, Y-軸, LF=120, Trifix®

ER 25	413502024-40R	1:1	EC
	00675000915		
ER 25	413502025-40R	1:1	IC 80 bar
	00675000915		

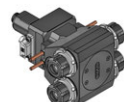

二軸直角鑽/銑動力刀座, 正主軸及副主軸加工用, Y-軸, LF=120, Trifix®

ER 25	413502026-40	1:1	EC
	00675000915		



刨削刀座(內外徑通用), 雙面排齒, LF=120

32 型式	414532013-40	1:1	EC
-------	--------------	-----	----

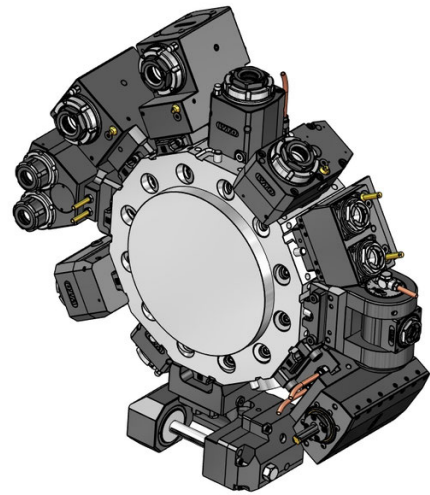
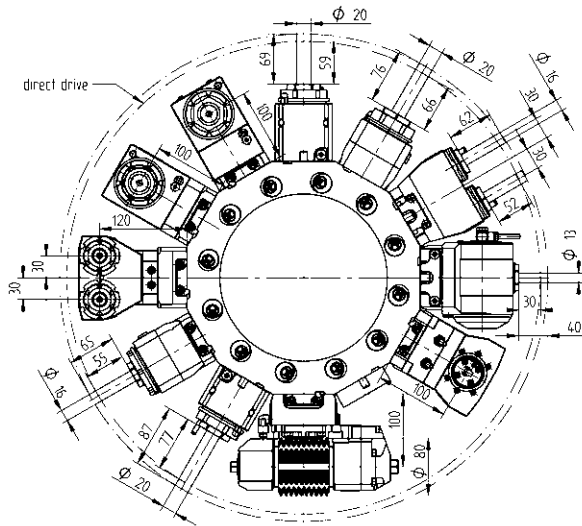

動力刀座 - 進階產品目錄



刨削刀座 (內外徑通用), Trifix®, LF=100 - BMT

32 型式	414532007-40L	1:1	EC
52 型式	414552001-40L	1:1	EC



刨削刀座 (內外徑通用), Trifix®, LF=100 - BMT

32 型式	414532007-40R	1:1	EC
52 型式	414552001-40R	1:1	EC

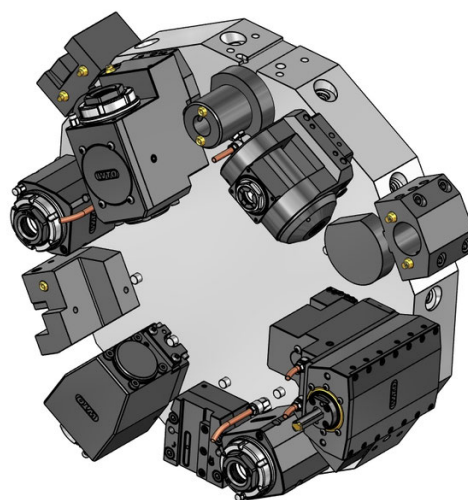
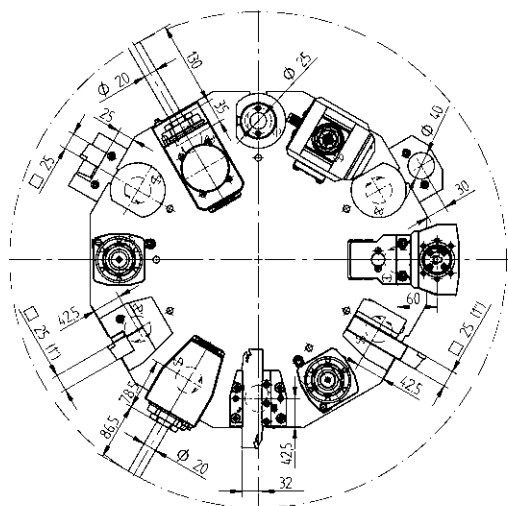

固定刀座 - 標準產品目錄



25 車端面刀座
48-PU2-25-25



組合刀座
 Ø 20 48-PU1-25-20 IC 80 bar
 Ø 25 48-PU1-25-25 IC 80 bar
 Ø 32 48-PU1-25-32 IC 80 bar
 Ø 40 48-PU1-25-40 IC 80 bar
 Ø 50 48-PU1-25-50 IC 80 bar



VDI 40 VDI接柄, 右手刀
48-99856



25(20) 徑向右手方形刀座, 短型, **B1**型式
48-B1-40x25

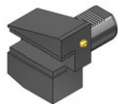

25(20) 徑向右手方形刀座, 反刀, 短型, **B3**型式
48-B3-40x25



25(20) 徑向右手方形刀座, 長型, **B5**型式
48-B5-40x25



25(20) 徑向右手方形刀座, 反刀, 長型, **B7**型式
48-B7-40x25

固定刀座 - 標準產品目錄



25 徑向方形刀座, **HP-IC - VDI** 雙面排齒
48-105989R-HP IC 80 bar
25 48-102790L-HP IC 80 bar

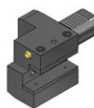

25(20) 方形刀柄軸向刀座, 右手刀, **C1**型式
48-C1-40x25

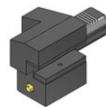

25(20) 方形刀柄軸向刀座, 右手反刀, **C3**型式
48-C3-40x25



SH 26 切斷刀用刀座, 中心高可微調, 右手刀
48-AR-40x26
SH 32 48-AR-40x32



SH 26 切斷刀用刀座, 中心高可微調, 右手反刀
48-ARU-40x26



SH 32 切斷刀用刀座, 中心高可微調, 中心出水, **HP-IC**
48-102690R IC 80 bar
SH 32 48-102690L IC 80 bar

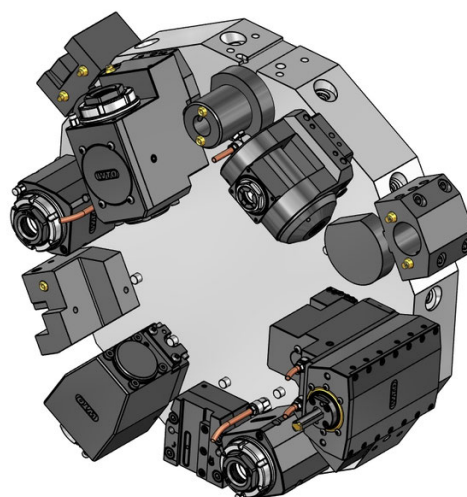
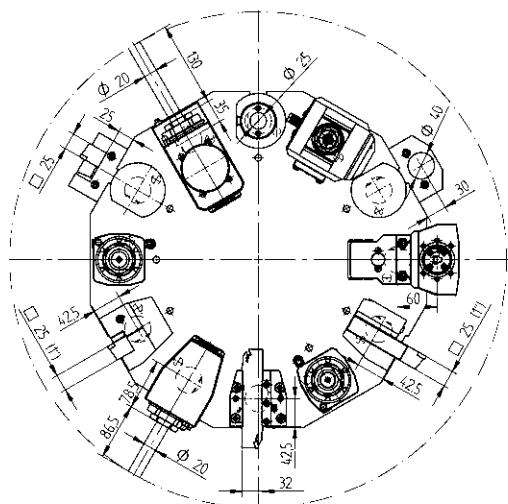

固定刀座 - 標準產品目錄



捨棄式刀片鑽頭刀座, 中心出水, E1型式

- Ø 16 48-E1-40x16
- Ø 20 48-E1-40x20
- Ø 25 48-E1-40x25
- Ø 32 48-E1-40x32
- Ø 40 48-E1-40x40



擔刀刀座, 中心出水, E2型式

- Ø 8 48-E2-40x8
- Ø 10 48-E2-40x10
- Ø 12 48-E2-40x12
- Ø 16 48-E2-40x16
- Ø 20 48-E2-40x20
- Ø 25 48-E2-40x25
- Ø 30 48-E2-40x30
- Ø 32 48-E2-40x32
- Ø 40 48-E2-40x40



ER筒夾刀座, DIN 6499B, 中心出水, E4型式

- ER 25 48-E4-40x25
107525000
- ER 32 48-E4-40x32
107532000
- ER 40 48-E4-40x40
107540000



防污塞, 鋼材, Z2型式
鋼材 48-Z2-40-S

動力刀座 - QuickFlex® 產品目錄



直結式鑽/銑動力刀座

- ER-32 QF 420132077-40R 1:1 EC
442145W, T32595
0067732000
- ER-32 QF 420132078-40R 1:1 IC 80 bar
0067732000



直角式鑽/銑動力刀座

- ER-32 QF 420532042-40R 1:1 EC
442275W
0067732000
- ER-32 QF 420532043-40R 1:1 IC 80 bar
0067732000



直角後縮式鑽/銑動力刀座

- ER-32 QF 420532037-40R 1:1 EC
0067732000
- ER-32 QF 420532038-40R 1:1 IC 80 bar
0067732000

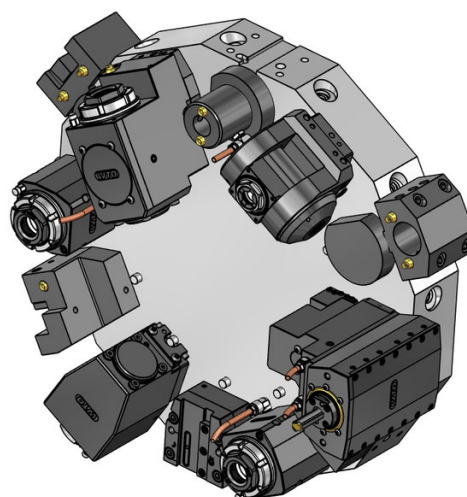
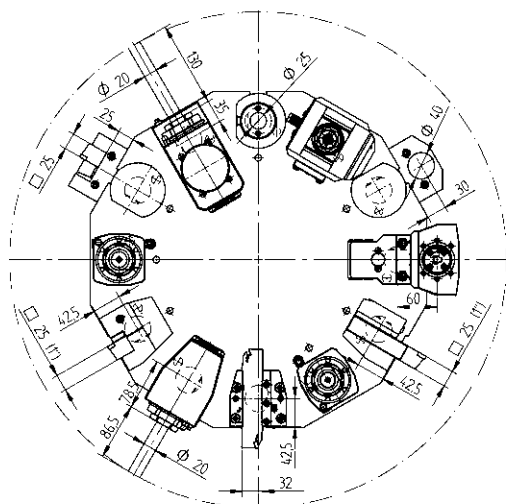

動力刀座 - 進階產品目錄

	直結式銑刀座 - 組合銑刀心軸, DIN6358		
Ø 22	410222025-40	1:1	EC
	 00675000479		
	直結偏位式鑽/銑動力刀座		
ER-32 QF	420132054-40R	1:1	EC
	 0067732000		
ER-32 QF	420132055-40R	1:1	IC 80 bar
	 0067732000		
ER-25 QF	420125024-40R	1:2	EC
	 0067725001		
ER-25 QF	420125025-40R	1:2	IC 80 bar
	 0067725001		
ER-32 QF	420132056-40R	2:1	EC
	 0067732000		
ER-32 QF	420132057-40R	2:1	IC 80 bar
	 0067732000		
	直結偏位式鑽/銑動力刀座 - VDI 雙面排齒		
ER 16	410410001-40	1:3	EC
	 00675000937		
ER 16	410410002-40	1:3	IC 80 bar
	 00675000937		

動力刀座 - 進階產品目錄

	直角式鑽/銑動力刀座		
ER-25 QF	420525058-40	1:2	EC
	 0067725001		
ER-25 QF	420525059-40	1:2	IC 80 bar
	 0067725001		
	直角後縮式鑽/銑動力刀座		
ER-40 QF	420540027-40R	2:1	EC
	 0067740000		
ER-40 QF	420540028-40R	2:1	IC 80 bar
	 0067740000		
	可調角度鑽/銑動力刀座		
ER 20	411013019-40	1:1	EC
	 00675000928		
ER 20	411013026-40	1:1	IC 80 bar
	 00675000928		
ER 25	411016006-40	1:1	EC
	 00675000934		
ER 25	411016024-40	1:1	IC 80 bar
	 00675000934		
ER 16	411010012-40	1:2	EC
	 00675000936		
ER 16	411010013-40	1:2	IC 80 bar
	 00675000936		

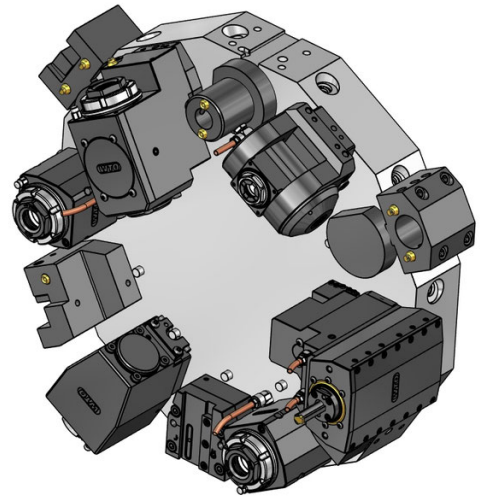
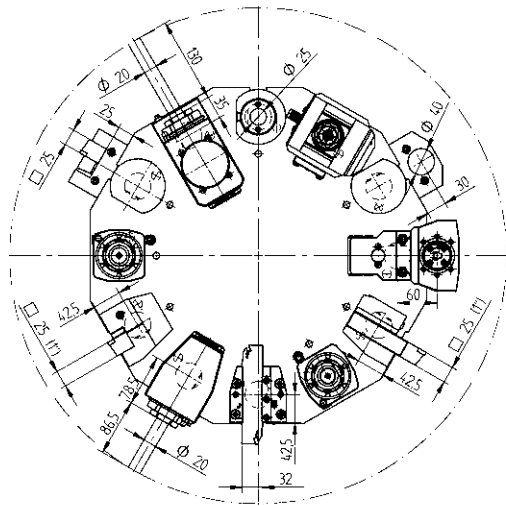

動力刀座 - 進階產品目錄



橫向圓鋸開槽刀座

14-2 型式 411500009-40 2,727:1EC

00675000460

160016142 Ø 16

160022142 Ø 22

160027142 Ø 27

160015142 Ø 5/8"

160019142 Ø 3/4"

160023142 Ø 7/8"

160025142 Ø 1"



刨削刀座(內外徑通用)

32 型式 414132002-40 1:1 EC

52 型式 414152000-40 1:1 EC

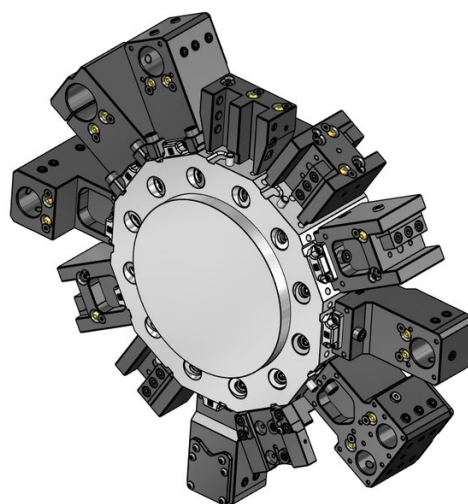
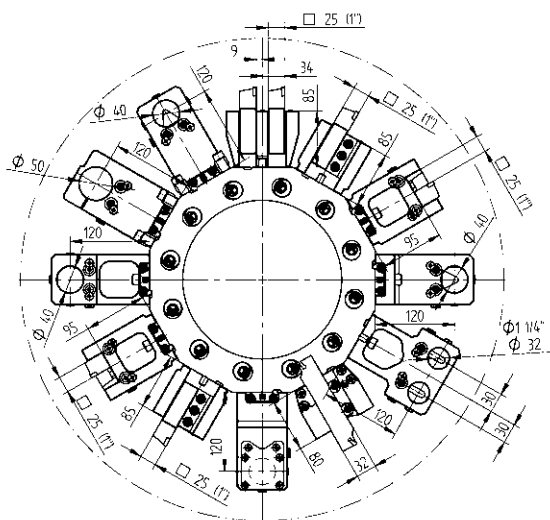

固定刀座 - 標準產品目錄

 外徑刀座 - VDI 雙面排齒
25 48-85982

 外徑刀座, 正主軸及副主軸加工用
25 48-59098
442340

 車端面刀座
25 48-87589

 車端面刀座, Trifix®
25 48-96528

 組合刀座, 通用, LF=120
Ø 40 48-64021
241140020 ER32

 組合刀座, 通用, Trifix®, LF=120
Ø 40 48-96530
T12138
241140020 ER32
241140026 ER40

固定刀座 - 標準產品目錄

 組合刀座, 後縮式 - VDI 雙面排齒, LF=120
Ø 40 48-110591
241140020 ER32

 組合刀座, 後縮式, 左手刀, Trifix®, LF=120
Ø 40 48-110694
241140026 ER40
241140020 ER32

 組合刀座, 後縮式, 右手刀, Trifix®, LF=120
Ø 40 48-97044
241140020 ER32
241140026 ER40

 組合刀座, 正主軸及副主軸加工用, LF=120
Ø 40 48-97388

 組合刀座, 正主軸及副主軸加工用, Trifix®, LF=120
Ø 40 48-97036
T12139

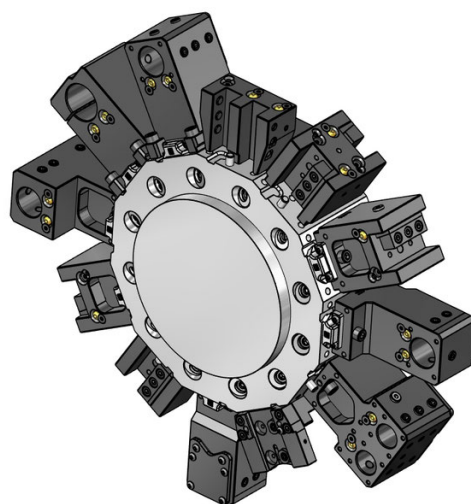
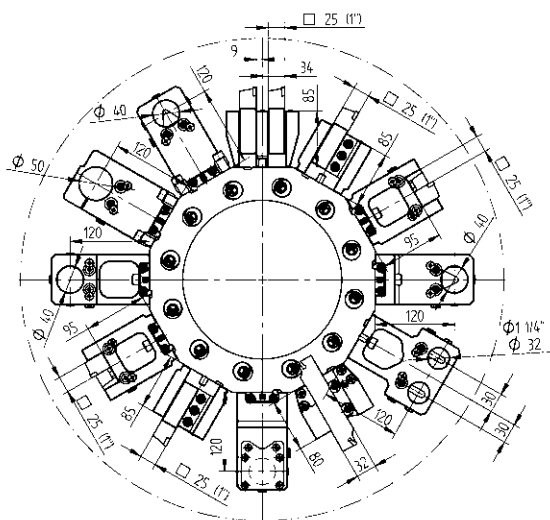

固定刀座 - 標準產品目錄

- 

筒夾刀座, 正主軸及副主軸加工用, LF=120

ER 32 48-66629 IC 80 bar
107532000

ER 40 48-97389 IC 80 bar
107540000
- 

筒夾刀座, 正主軸及副主軸加工用, Trifix®, LF=120

ER 32 48-97051 IC 80 bar
107532000

ER 40 48-97052 IC 80 bar
107540000
- 

防污塞, 鋼材, Z2型式

鋼材 48-Z2-40-S

固定刀座 - 進階產品目錄

- 

外徑刀座, HP-IC 高壓中心出水 - VDI 雙面排齒

25 48-105986-HP IC 80 bar
- 

外徑刀座, 正主軸及副主軸加工用, HP-IC

25 48-59098-HP
- 

外徑刀座, 2刀位, Y-軸 - VDI 雙面排齒

25(1") 48-86080
- 

外徑刀座, 正主軸及副主軸加工用, 2刀位, Y-軸

25(1") 48-89779
- 

切斷刀用刀座, 中心高可微調 - VDI 雙面排齒

SH 32 48-98963
R9Z455, T00460, T00461
- 

切斷刀用刀座, 中心高可微調, 中心出水, HP-IC - VDI 雙面排齒

SH 32 48-102643R IC 80 bar
SH 32 48-102643L IC 80 bar

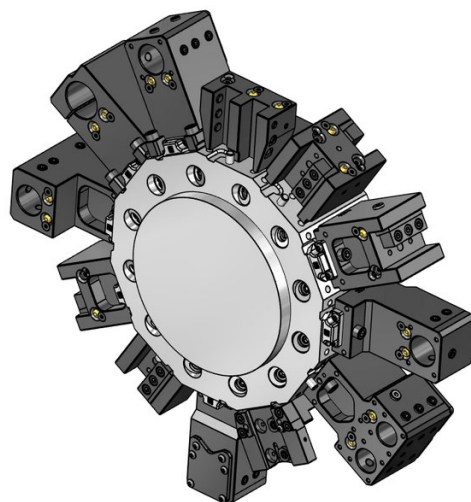
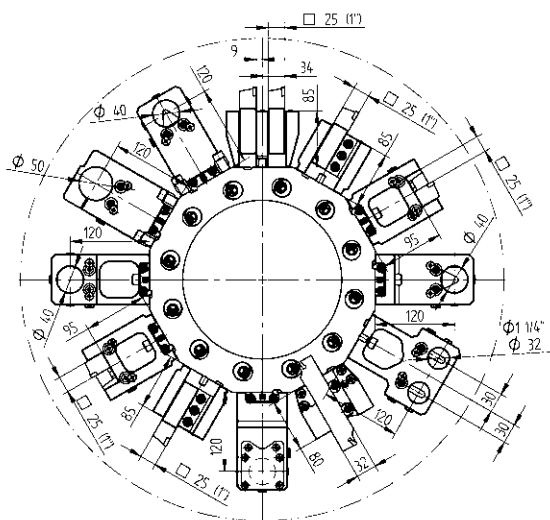

固定刀座 - 進階產品目錄



切斷刀用刀座, 中心高可微調, 長型, 中心出水, **HP-IC - VDI 雙面排齒**

- SH 32** 48-99091R IC 80 bar
- 343-810100R8
- SH 32** 48-99091L IC 80 bar
- 343-810100L8



組合刀座, 通用, **Trifix®, LF=120 - BMT**

- Ø 40** 48-97097
- 241140020 ER32
- 241140026 ER40



組合刀座, 後縮式, 左面, **Trifix®, LF=120 - BMT**

- Ø 40** 48-111059
- 241140020 ER32
- 241140026 ER40



組合刀座, 後縮式, 右面, **Trifix®, LF=120 - BMT**

- Ø 40** 48-97164
- 241140020 ER32
- 241140026 ER40



組合刀座, 正主軸及副主軸加工用, **Trifix®, LF=120 - BMT**

- Ø 40** 48-97105

固定刀座 - 進階產品目錄



擔刀刀座, 帶槽全周夾緊, **Trifix®, LF=120 - BMT**

- Ø 50** 48-97257



組合刀座, 通用, 2刀位, Y-軸, **LF=120**

- Ø 32** 48-86296
- 241132016 ER25
- 241132020 ER32



組合刀座, 通用, 2刀位, Y-軸, **LF=120, Trifix®**

- Ø 32** 48-96531
- 241132016 ER25
- 241132020 ER32

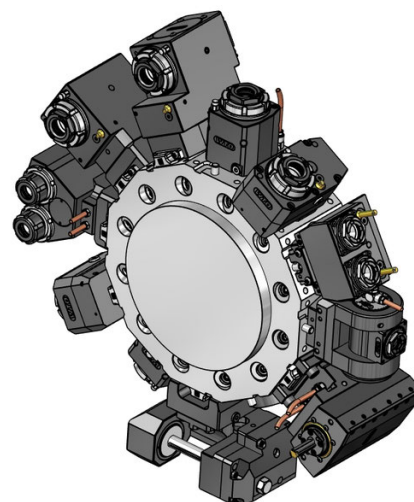
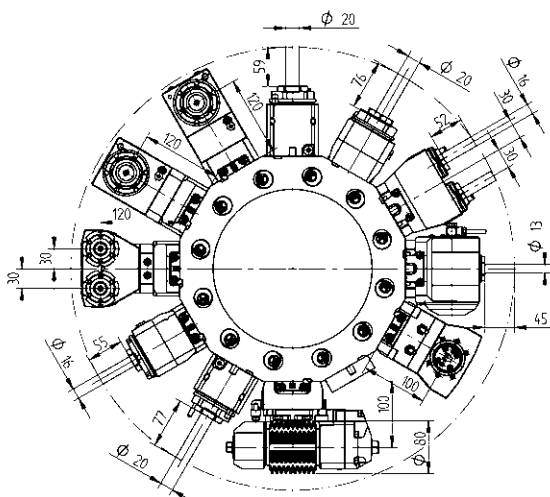

動力刀座 - QuickFlex® 產品目錄

-  **直結式鑽/銑動力刀座 (6000 RPM)**
- | | | | |
|-----------------|-----------------------------|-----|-----------|
| ER-32 QF | 420132077-40L
0067732000 | 1:1 | EC |
| ER-32 QF | 420132078-40L
0067732000 | 1:1 | IC 80 bar |

-  **直結式鑽/銑動力刀座 (10000 RPM)**
- | | | | |
|-----------------|--|-----|-----------|
| ER-32 QF | 420132069-40L
442141W
0067732000 | 1:1 | EC |
| ER-32 QF | 420132070-40L
0067732000 | 1:1 | IC 80 bar |

-  **直角式鑽/銑動力刀座, Trifix®, LF=120, (6000 RPM)**
- | | | | |
|-----------------|---------------------------------------|-----|-----------|
| ER-32 QF | 420532018-40L
T32591
0067732000 | 1:1 | EC |
| ER-32 QF | 420532019-40L
0067732000 | 1:1 | IC 80 bar |

-  **直角式鑽/銑動力刀座, Trifix®, LF=120, (10000 RPM)**
- | | | | |
|-----------------|---------------------------------------|-----|-----------|
| ER-32 QF | 420532026-40L
T32593
0067732000 | 1:1 | EC |
| ER-32 QF | 420532027-40L
0067732000 | 1:1 | IC 80 bar |

動力刀座 - QuickFlex® 產品目錄

-  **直角式鑽/銑動力刀座, Trifix®, LF=120, (6000 RPM)**
- | | | | |
|-----------------|---------------------------------------|-----|-----------|
| ER-32 QF | 420532018-40R
T32592
0067732000 | 1:1 | EC |
| ER-32 QF | 420532019-40R
0067732000 | 1:1 | IC 80 bar |

-  **直角式鑽/銑動力刀座, Trifix®, LF=120, (10000 RPM)**
- | | | | |
|-----------------|---------------------------------------|-----|-----------|
| ER-32 QF | 420532026-40R
T32594
0067732000 | 1:1 | EC |
| ER-32 QF | 420532027-40R
0067732000 | 1:1 | IC 80 bar |

-  **直角後縮式鑽/銑動力刀座, Trifix®, LF=120, (6000 RPM)**
- | | | | |
|-----------------|-----------------------------|-----|-----------|
| ER-32 QF | 420532034-40L
0067732000 | 1:1 | EC |
| ER-32 QF | 420532035-40L
0067732000 | 1:1 | IC 80 bar |

-  **直角後縮式鑽/銑動力刀座, Trifix®, LF=120, (10000 RPM)**
- | | | | |
|-----------------|-----------------------------|-----|-----------|
| ER-32 QF | 420532064-40L
0067732000 | 1:1 | EC |
| ER-32 QF | 420532065-40L
0067732000 | 1:1 | IC 80 bar |

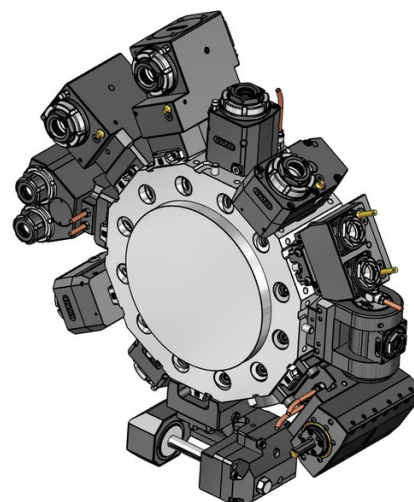
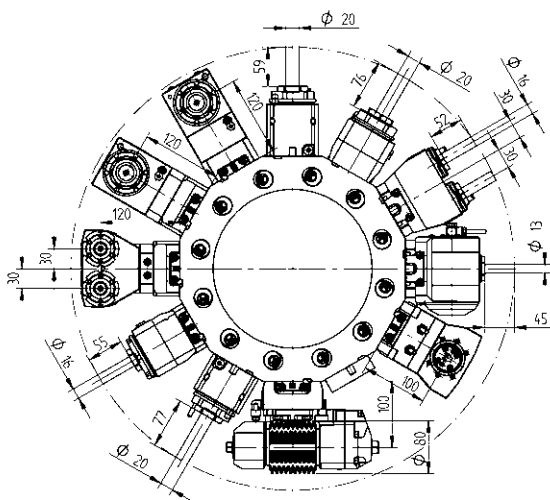

動力刀座 - QuickFlex® 產品目錄

動力刀座 - 進階產品目錄



直角後縮式鑽/銑動力刀座, Trifix®, LF=120, (6000 RPM)

- ER-32 QF 420532034-40R 1:1 EC
0067732000
- ER-32 QF 420532035-40R 1:1 IC 80 bar
0067732000



直角後縮式鑽/銑動力刀座, Trifix®, LF=120, (10000 RPM)

- ER-32 QF 420532064-40R 1:1 EC
0067732000
- ER-32 QF 420532065-40R 1:1 IC 80 bar
0067732000



直角式鑽/銑動力刀座, 正主軸及副主軸加工用, Trifix®, LF=120, (6000 RPM)

- ER-32 QF 420532020-40 T32597 1:1 EC
0067732000



直角式鑽/銑動力刀座, 正主軸及副主軸加工用, Trifix®, LF=120, (10000 RPM)

- ER-32 QF 420532127-40 1:1 EC
0067732000



直結式鑽/銑動力刀座 - BMT

- ER-40 QF 420140010-40 1:1 EC
0067740000
- ER-40 QF 420140011-40 1:1 IC 80 bar
0067740000



直結式銑刀座 - 組合銑刀心軸, DIN6358

- Ø 22 410222025-40 1:1 EC
00675000479



直結式銑刀座 - BMT - 組合銑刀心軸, DIN6358

- Ø 22 410222022-40 1:1 EC
00675000479
- Ø 27 410227010-40 1:1 EC
00675000480

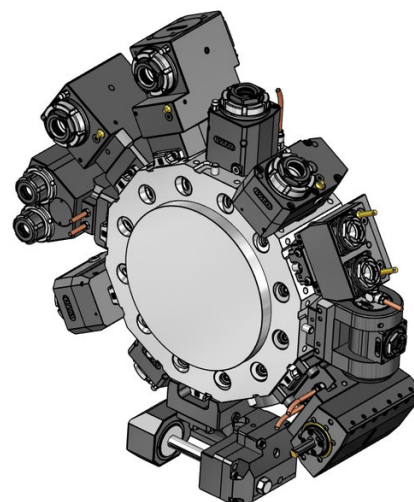
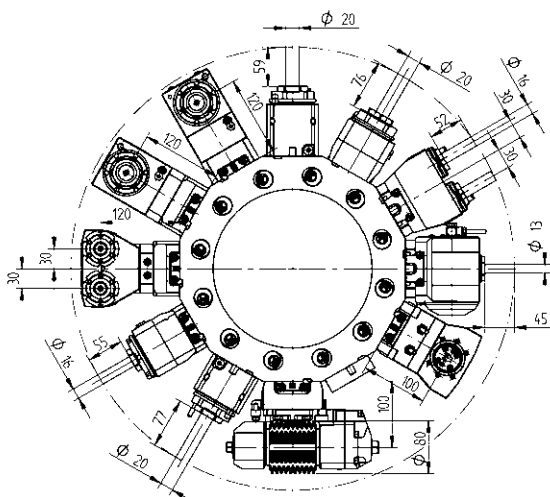

動力刀座 - 進階產品目錄



直結偏位式鑽/銑動力刀座

ER-32 QF	420132054-40L 0067732000	1:1	EC
ER-32 QF	420132055-40L 0067732000	1:1	IC 80 bar
ER-25 QF	420125024-40L 0067725001	1:2	EC
ER-25 QF	420125025-40L 0067725001	1:2	IC 80 bar
ER-32 QF	420132056-40L 0067732000	2:1	EC
ER-32 QF	420132057-40L 0067732000	2:1	IC 80 bar



直結偏位式鑽/銑動力刀座, Trifix®

ER-25 QF	420125039-40L 0067725001	1:2	EC
ER-25 QF	420125038-40L 0067725001	1:2	IC 80 bar



直結偏位式鑽/銑動力刀座, Trifix®

ER-25 QF	420125039-40R 0067725001	1:2	EC
ER-25 QF	420125038-40R 0067725001	1:2	IC 80 bar

動力刀座 - 進階產品目錄



直角式鑽/銑動力刀座, Trifix®, LF=100 - BMT

ER-32 QF	420532028-40L 0067732000	1:1	EC
ER-32 QF	420532029-40L 0067732000	1:1	IC 80 bar
ER-40 QF	420540010-40L 0067740000	2:1	EC
ER-40 QF	420540011-40L 0067740000	2:1	IC 80 bar



直角式鑽/銑動力刀座, Trifix®, LF=100 - BMT

ER-32 QF	420532028-40R 0067732000	1:1	EC
ER-32 QF	420532029-40R 0067732000	1:1	IC 80 bar
ER-40 QF	420540010-40R 0067740000	2:1	EC
ER-40 QF	420540011-40R 0067740000	2:1	IC 80 bar



直角式鑽/銑動力刀座, Trifix®, LF=120 - BMT

ER-32 QF	420532030-40L 0067732000	1:1	EC
ER-32 QF	420532031-40L 0067732000	1:1	IC 80 bar
ER-40 QF	420540014-40L 0067740000	1:1	EC
ER-40 QF	420540015-40L 0067740000	1:1	IC 80 bar

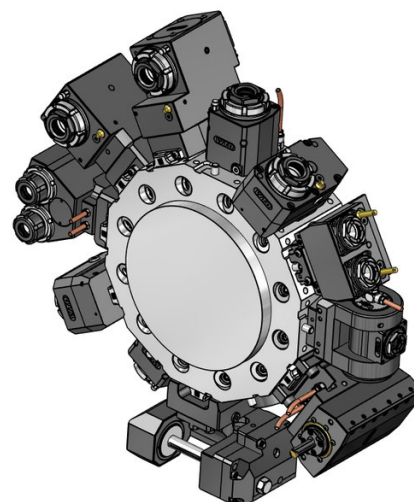
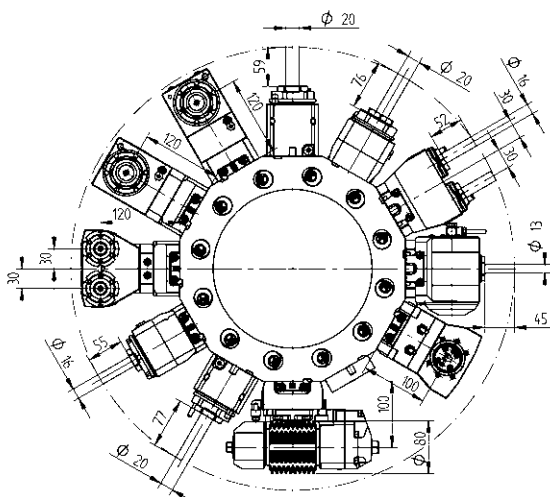

動力刀座 - 進階產品目錄

- 

直角式鑽/銑動力刀座, Trifix®, LF=120 - BMT

ER-32 QF	420532030-40R	1:1	EC
	 0067732000		
ER-32 QF	420532031-40R	1:1	IC 80 bar
	 0067732000		
ER-40 QF	420540014-40R	1:1	EC
	 0067740000		
ER-40 QF	420540015-40R	1:1	IC 80 bar
	 0067740000		

- 

直角式鑽/銑動力刀座, Trifix®, LF=120

ER-25 QF	420525019-40L	1:2	EC
	 0067725000		
ER-25 QF	420525020-40L	1:2	IC 80 bar
	 0067725000		

- 

直角式鑽/銑動力刀座, Trifix®, LF=120

ER-25 QF	420525019-40R	1:2	EC
	 0067725000		
ER-25 QF	420525020-40R	1:2	IC 80 bar
	 0067725000		

- 

直角式鑽/銑動力刀座, 正主軸及副主軸加工用, Trifix®, LF=120 - BMT

ER-40 QF	420540016-40	1:1	EC
	 0067740000		

動力刀座 - 進階產品目錄

- 

直角式銑動力刀座 - VDI 雙面排齒, LF=100

Ø 22	410622028-40	2:1	EC
	 00675000160		
Ø 27	410627015-40	2:1	EC
	 00675000211		

- 

直角式銑動力刀座, Trifix®, LF=100 - BMT

Ø 22	410622031-40L	2:1	EC
	 00675000160		
Ø 27	410627016-40L	2:1	EC
	 00675000211		

- 

直角式銑動力刀座, Trifix®, LF=100 - BMT

Ø 22	410622031-40R	2:1	EC
	 00675000160		
Ø 27	410627016-40R	2:1	EC
	 00675000211		

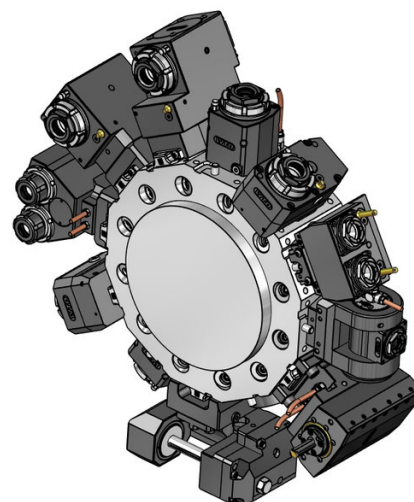
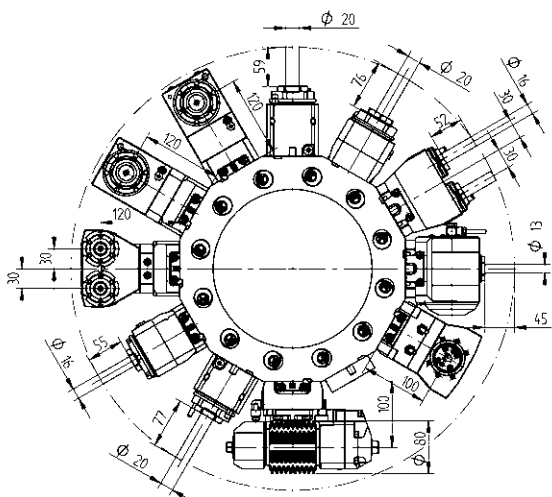

動力刀座 - 進階產品目錄

動力刀座 - 進階產品目錄



可調角度鑽/銑動力刀座

ER 20	411013019-40 00675000928	1:1	EC
ER 20	411013026-40 00675000928	1:1	IC 80 bar
ER 25	411016006-40 00675000934	1:1	EC
ER 25	411016024-40 00675000934	1:1	IC 80 bar
ER 16	411010012-40 00675000936	1:2	EC
ER 16	411010013-40 00675000936	1:2	IC 80 bar



滾齒刀座, Trifix®

16-1 型式	411500041-40L	1:1	EC
16-1 型式	411500037-40L	2:1	EC
	00675000928		
	160016161 Ø 16		
	160022161 Ø 22		
	160027161 Ø 27		
	160015161 Ø 5/8"		
	160019161 Ø 3/4"		
	160025161 Ø 1"		
	160031161 Ø 1 1/4"		
	110587		



圓鋸開槽銑刀刀座

14-2 型式	410900013-40 00675000460	2,615:1	EC
	160016142 Ø 16		
	160022142 Ø 22		
	160027142 Ø 27		
	160015142 Ø 5/8"		
	160019142 Ø 3/4"		
	160023142 Ø 7/8"		
	160025142 Ø 1"		



滾齒刀座, Trifix®

16-1 型式	411500041-40R	1:1	EC
16-1 型式	411500037-40R	2:1	EC
	110587		
	160031161 Ø 1 1/4"		
	160022161 Ø 22		
	160016161 Ø 16		
	00675000928		
	160027161 Ø 27		
	160025161 Ø 1"		
	160019161 Ø 3/4"		
	160015161 Ø 5/8"		

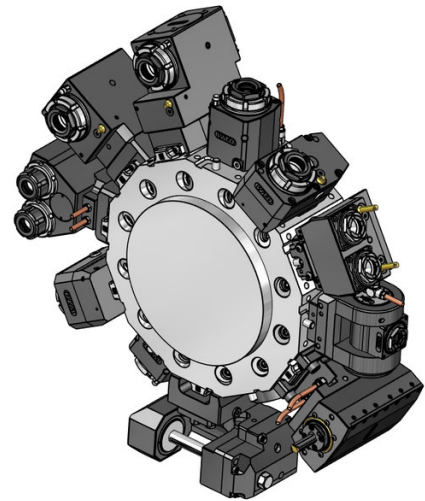
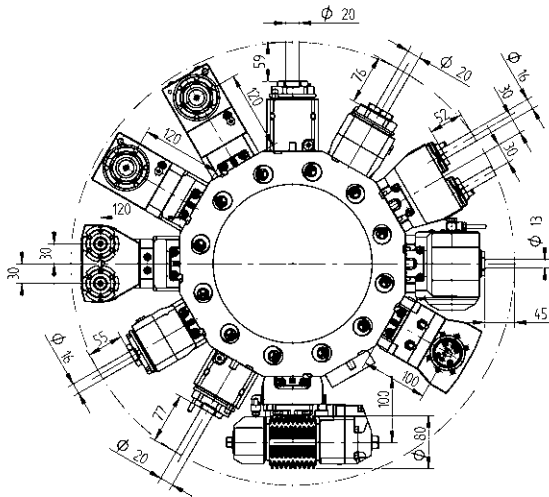

動力刀座 - 進階產品目錄

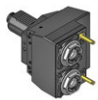

直結式鑽/銑刀座, 2刀位, Y-軸

ER 25 413002034-40 1:1,5 EC

00675000930

ER 25 413002035-40 1:1,5 IC 80 bar

00675000930

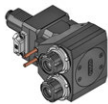

二軸直角鑽/銑動力刀座, Y-軸, LF=120, Trifix®

ER 25 413502024-40L 1:1 EC

00675000915

ER 25 413502025-40L 1:1 IC 80 bar

00675000915



二軸直角鑽/銑動力刀座, Y-軸, LF=120, Trifix®

ER 25 413502024-40R 1:1 EC

00675000915

ER 25 413502025-40R 1:1 IC 80 bar

00675000915



二軸直角鑽/銑動力刀座, 正主軸及副主軸加工用, Y-軸, LF=120, Trifix®

ER 25 413502026-40 1:1 EC

00675000915



刨削刀座(內外徑通用), 雙面排齒, LF=120

32 型式 414532013-40 1:1 EC

動力刀座 - 進階產品目錄



刨削刀座 (內外徑通用), Trifix®, LF=100 - BMT

32 型式 414532007-40L 1:1 EC

52 型式 414552001-40L 1:1 EC



刨削刀座 (內外徑通用), Trifix®, LF=100 - BMT

32 型式 414532007-40R 1:1 EC

52 型式 414552001-40R 1:1 EC

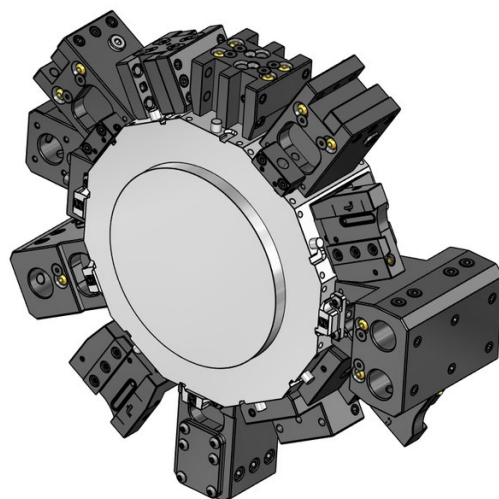
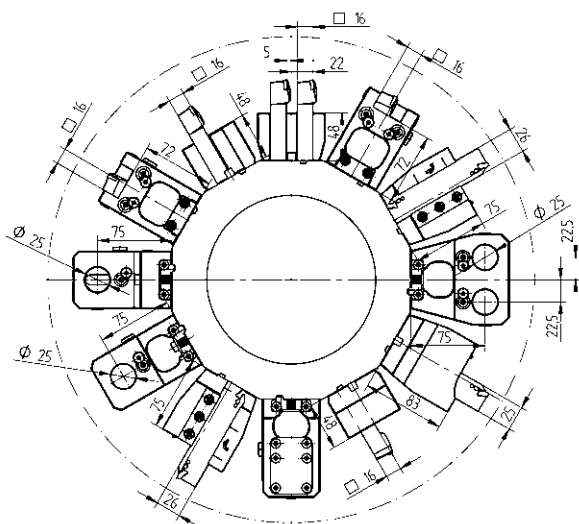

固定刀座 - 標準產品目錄

- 

16(12) 方形刀柄軸向刀座, 右手刀, C1型式
48-C1-25x16
- 

16(12) 方形刀柄軸向刀座, 左手刀, C2型式
48-C2-25x16
- 

16(12) 方形刀柄軸向刀座, 右手反刀, C3型式
48-C3-25x16
- 

16(12) 方形刀柄軸向刀座, 左手反刀, C4型式
48-C4-25x16
- 

16 外徑刀座 - VDI 雙面排齒
48-88237
R2Z415W
- 

20 外徑刀座, HP-IC 高壓中心出水 - VDI 雙面排齒
48-106423-HP IC 80 bar
- 

16 外徑刀座, 正主軸及副主軸加工用
48-71572
R2Z810W

固定刀座 - 標準產品目錄

- 

20 外徑刀座, 正主軸及副主軸加工用, HP-IC
48-111171-HP IC 80 bar
- 

16 車端面刀座
48-74693
- 

Ø 25 組合刀座, 通用
48-74687
241125016 ER25
- 

Ø 25 組合刀座, 通用, Trifix®
48-98234
241125016 ER25
- 

Ø 25 組合刀座, 後縮式, 左手刀
48-74689
241125016 ER25
- 

Ø 25 組合刀座, 後縮式, 左手刀, Trifix®
48-98235
241125016 ER25

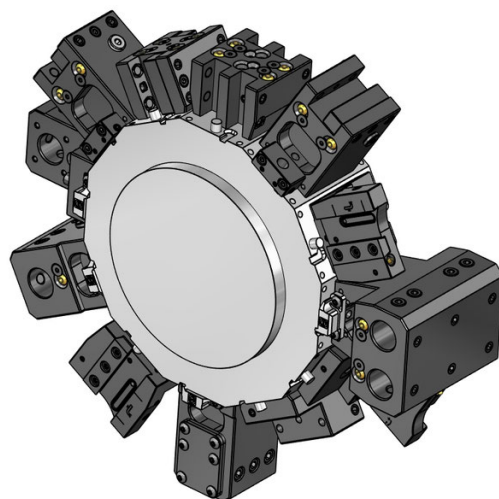
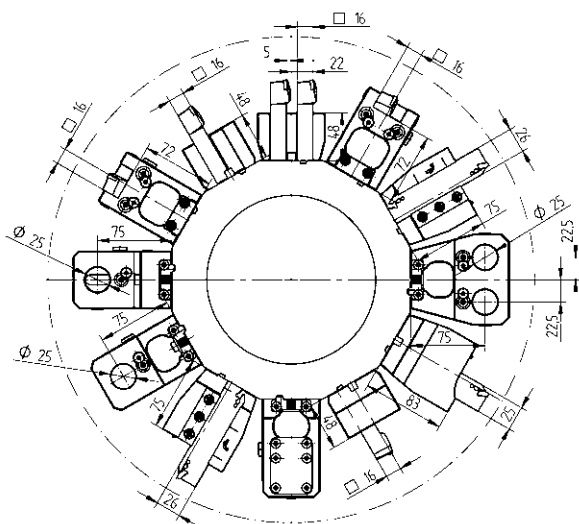

固定刀座 - 標準產品目錄



組合刀座, 後縮式, 右手刀

Ø 25 48-74688
241125016 ER25



組合刀座, 後縮式, 右手刀, Trifix®

Ø 25 48-98236
241125016 ER25



組合刀座, 正主軸及副主軸加工用

Ø 25 48-74690



組合刀座, 正主軸及副主軸加工用, Trifix®

Ø 25 48-98238

固定刀座 - 進階產品目錄



外徑刀座, 正主軸及副主軸加工用, 2刀位, Y-軸

16(5/8") 48-77394
442770W



車端面刀座, HP-IC - VDI 雙面排齒

20 48-107434-HP IC 80 bar



切斷刀用刀座, 中心高可微調 - VDI 雙面排齒

SH 26 48-98981
R2Z452W



切斷刀用刀座, 中心高可微調, 中心出水, HP-IC - VDI 雙面排齒

SH 26 48-102647R IC 80 bar
SH 26 48-102647L IC 80 bar
SH 32 48-106937R IC 80 bar
343-810100R80
SH 32 48-106937L IC 80 bar
343-810100L80



組合刀座, 2刀位, 正主軸及副主軸加工用

Ø 25 48-119657



組合刀座, 2刀位, 正主軸及副主軸加工用, Trifix®

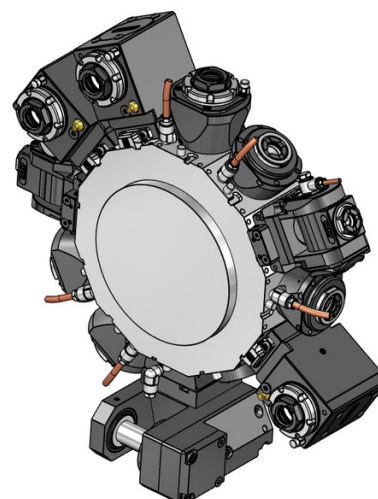
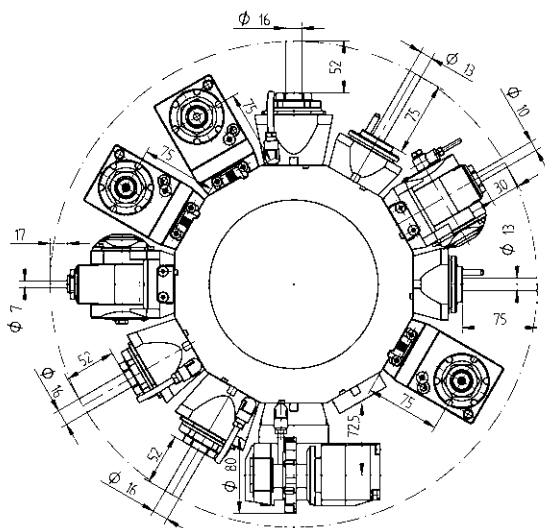

Ø 25 48-109204



動力刀座 - QuickFlex® 產品目錄

- 

直結式鑽/銑動力刀座

ER-25 QF	420125010-25 R2Z471W	1:1	EC
	 0067725010		
ER-25 QF	420125011-25	1:1	IC 80 bar
	 0067725010		

- 

直角式鑽/銑動力刀座, Trifix®

ER-25 QF	420525010-25L	1:1	EC
	 0067725010		
ER-25 QF	420525011-25L	1:1	IC 80 bar
	 0067725010		



- 

直角式鑽/銑動力刀座, Trifix®

ER-25 QF	420525010-25R	1:1	EC
	 0067725010		
ER-25 QF	420525011-25R	1:1	IC 80 bar
	 0067725010		

- 

直角後縮式鑽/銑動力刀座, Trifix®

ER-25 QF	420525027-25L	1:1	EC
	 0067725010		
ER-25 QF	420525028-25L	1:1	IC 80 bar
	 0067725010		

動力刀座 - QuickFlex® 產品目錄

- 

直角後縮式鑽/銑動力刀座, Trifix®

ER-25 QF	420525027-25R	1:1	EC
	 0067725010		
ER-25 QF	420525028-25R	1:1	IC 80 bar
	 0067725010		

- 

直角式鑽/銑動力刀座, 正主軸及副主軸加工用, Trifix®

ER-25 QF	420525012-25	1:1	EC
	 0067725010		

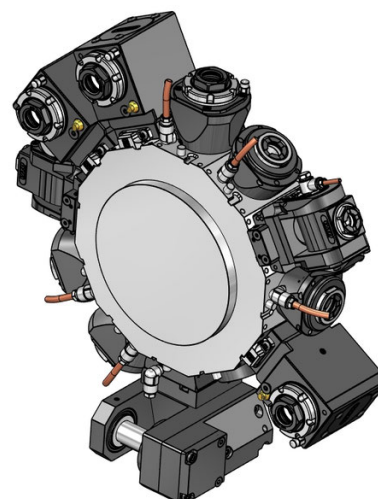
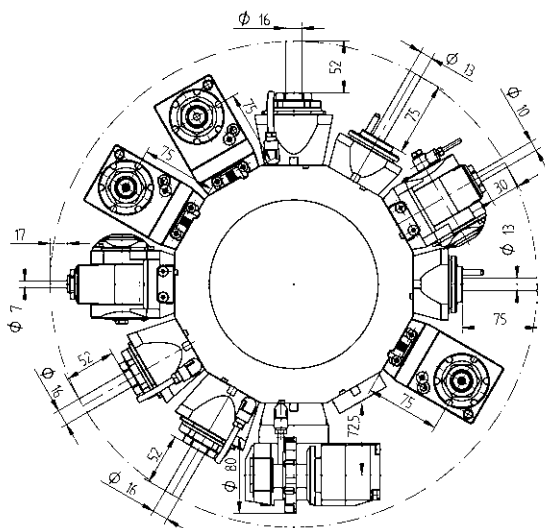

動力刀座 - 進階產品目錄



直結式鑽/銑動力刀座, 短型

ER 20 410113004-25 1:1 EC
R2Z490
00675000700



直結式銑刀座 - 組合銑刀心軸, **DIN6358**

Ø 16 410216003-25 1:1 EC
00675000854

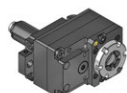

直結偏位式鑽/銑動力刀座

ER 25 410116017-25 1:1 EC
00675000801
ER 20 410113003-25 1:2 EC
00675000887
ER 16 410410000-25 1:3 EC
00675000636
ER 25 410116013-25 2:1 EC
00675000801

動力刀座 - 進階產品目錄



直角式鑽/銑動力刀座

ER-20 QF 420520019-25 1:2 EC
0067720011
ER-20 QF 420520020-25 1:2 IC 80 bar
0067720011
ER 16 410810012-25 1:3 EC
00675000841
ER 16 410810013-25 1:3 IC 80 bar
00675000841
ER-25 QF 420525032-25 2:1 EC
0067725010
ER-25 QF 420525033-25 2:1 IC 80 bar
0067725010



直角式銑動力刀座 - 組合銑刀心軸, **DIN6358**

Ø 16 410616002-25 1:1 EC
00675000854
Ø 22 410622005-25 2:1 EC
00675000483
Ø 27 410627002-25 2:1 EC
00675000245

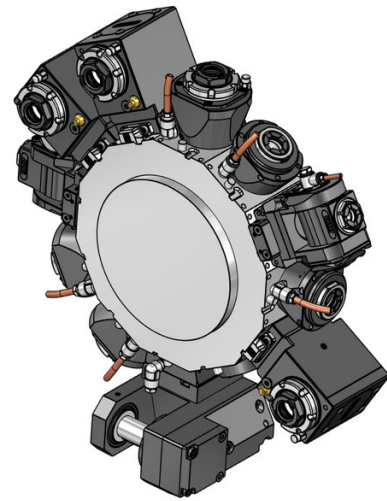
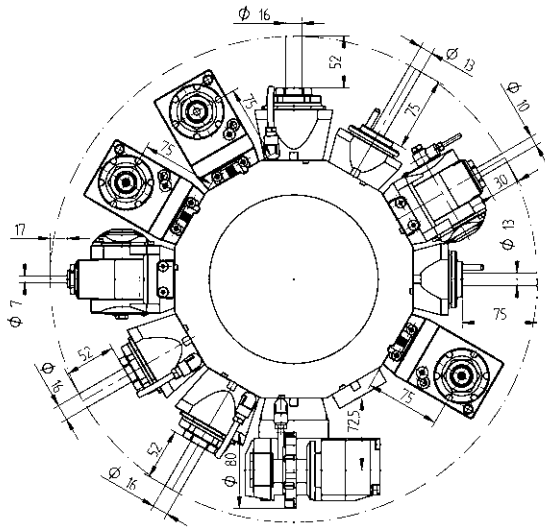

動力刀座 - 進階產品目錄

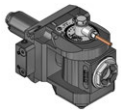

可調角度鑽/銑動力刀座

ER 16	411010003-25 00675000902	1:1	EC
ER 16	411010010-25 00675000902	1:1	IC 80 bar
ER 11	411007006-25 00675000914	1:2	EC
ER 11	411007007-25 00675000914	1:2	IC 80 bar



橫向圓鋸開槽刀座

14-2 型式	411500002-25 00675000460	2,727:1EC
	160016142 Ø 16	
	160022142 Ø 22	
	160027142 Ø 27	
	160015142 Ø 5/8"	
	160019142 Ø 3/4"	
	160023142 Ø 7/8"	
	160025142 Ø 1"	

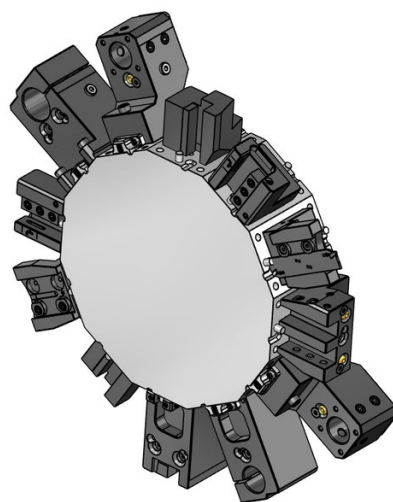
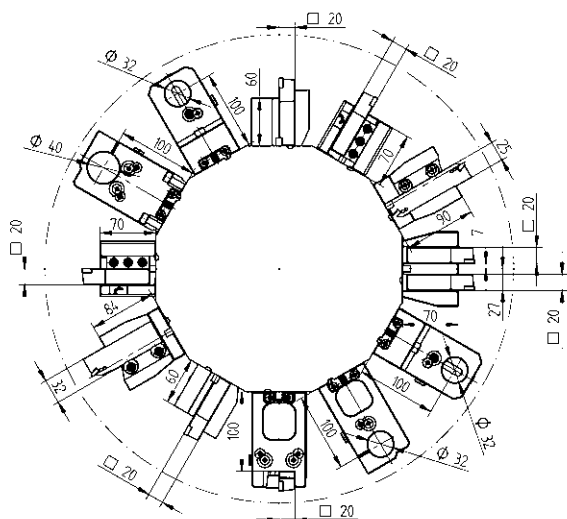

固定刀座 - 標準產品目錄

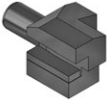
- 

方形刀柄軸向刀座, 右手刀, **C1**型式
20(16) 48-C1-30x20
- 

方形刀柄軸向刀座, 左手刀, **C2**型式
20(16) 48-C2-30x20
- 

方形刀柄軸向刀座, 右手反刀, **C3**型式
20(16) 48-C3-30x20
- 

方形刀柄軸向刀座, 左手反刀, **C4**型式
20(16) 48-C4-30x20
- 

方形刀柄刀座, **D1** 型式
20(16) 48-D1-30x20
- 

方形刀柄刀座, 反刀, **D2** 型式
20(16) 48-D2-30x20
- 

外徑刀座, 左手刀
20 48-71932
 R4Z410W

固定刀座 - 標準產品目錄



- 



外徑刀座, 右手刀
20 48-72047
 R4Z230W
- 

外徑刀座, 正主軸及副主軸加工用
20 48-71216
 R6Z410W
- 

車端面刀座
20 48-105756
- 

車端面刀座, **Trifix®**
20 48-109793
- 

組合刀座, 通用, **LF=100**
Ø 32 48-71434
 241132016 ER25
 241132020 ER32
- 

組合刀座, 通用, **Trifix®, LF=100**
Ø 32 48-96995
 241132016 ER25
 241132020 ER32

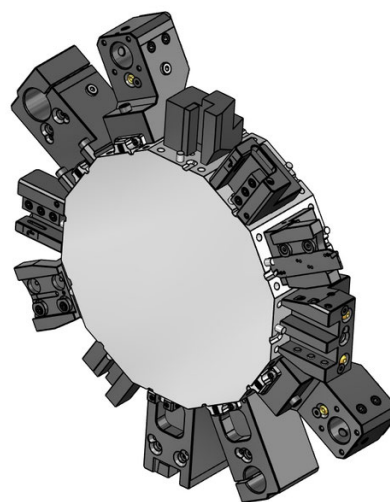
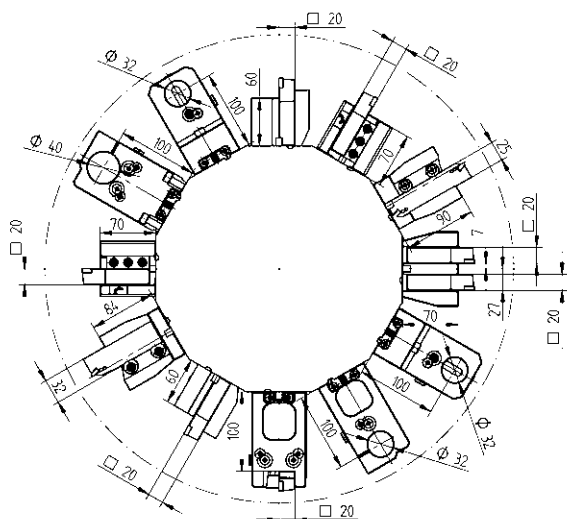

固定刀座 - 標準產品目錄

固定刀座 - 標準產品目錄



組合刀座, 後縮式, 左手刀, LF=100

- Ø 32 48-71438
- 241132016 ER25
- 241132020 ER32



組合刀座, 後縮式, 左手刀, Trifix®, LF=100

- Ø 32 48-97531
- 241132016 ER25
- 241132020 ER32



組合刀座, 後縮式, 右手刀, LF=100

- Ø 32 48-71436
- 241132016 ER25
- 241132020 ER32



組合刀座, 後縮式, 右手刀, Trifix®, LF=100

- Ø 32 48-97553
- 241132016 ER25
- 241132020 ER32



筒夾刀座, LF=100

- ER 32 48-82824 IC 80 bar
- 107532000



筒夾刀座, Trifix®, LF=100

- ER 32 48-100198 IC 80 bar
- 107532000



筒夾刀座, 正主軸及副主軸加工用, LF=100

- ER 32 48-82847 IC 80 bar
- 107532000

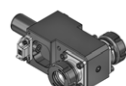

筒夾刀座, 正主軸及副主軸加工用, Trifix®, LF=100

- ER 32 48-100199 IC 80 bar
- 107532000



防污塞, 鋼材, Z2型式

- 鋼材 48-Z2-30-S

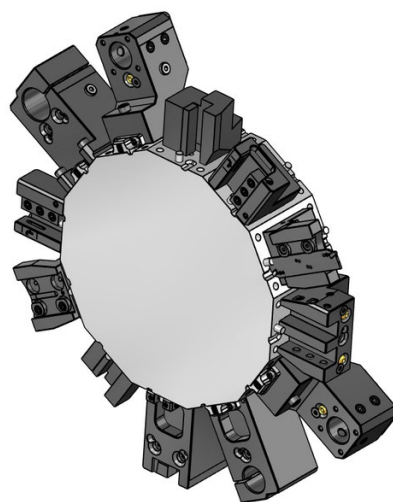
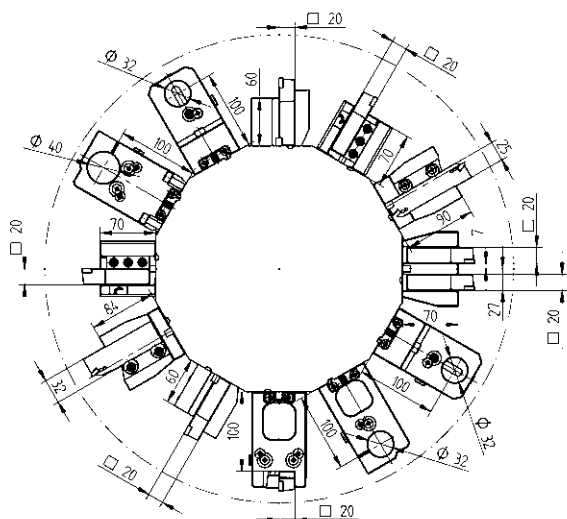

固定刀座 - 進階產品目錄

- 

20 外徑刀座, **HP-IC** 高壓中心出水 - **VDI** 雙面排齒
48-105977-HP IC 80 bar
- 

20 外徑刀座, 正主軸及副主軸加工用, **HP-IC**
48-71216-HP IC 80 bar
- 

20 (3/4") 外徑刀座, 2刀位, **Y-軸** - **VDI** 雙面排齒
48-84593
- 

20 (3/4") 外徑刀座, 正主軸及副主軸加工用, 2刀位, **Y-軸**
48-77395
442750W
- 

SH 26 切斷刀用刀座, 中心高可微調 - **VDI** 雙面排齒
48-98991
R4Z451W

SH 32 48-99017
R9Z450
- 

SH 26 切斷刀用刀座, 中心高可微調, 中心出水, **HP-IC** - **VDI** 雙面排齒
48-102630R IC 80 bar
343-810100R42

SH 26 48-102630L IC 80 bar
343-810100L42

SH 32 48-102632R IC 80 bar

SH 32 48-102632L IC 80 bar

固定刀座 - 進階產品目錄

- 

Ø 40 組合刀座, 通用, **Trifix®**, **LF=100** - **BMT**
48-99669
241140020 ER32
241140026 ER40
- 

Ø 32 搪刀刀座, 帶槽全周夾緊, **LF=100**
48-87088
- 

Ø 32 搪刀刀座, 帶槽全周夾緊, **Trifix®**, **LF=100**
48-97588
- 

Ø 40 搪刀刀座, 帶槽全周夾緊, **Trifix®**, **LF=100** - **BMT**
48-96994
- 

Ø 25 組合刀座, 通用, 2刀位, **Y-軸**, **LF=100**
48-79026
241125016 ER25
- 

Ø 25 組合刀座, 通用, 2刀位, **Y-軸**, **LF=100**, **Trifix®**
48-99635
241125016 ER25

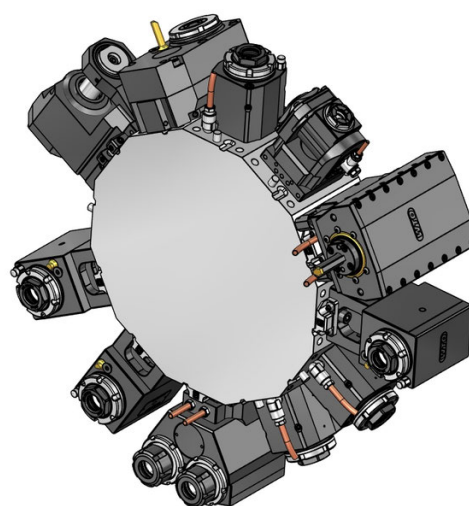
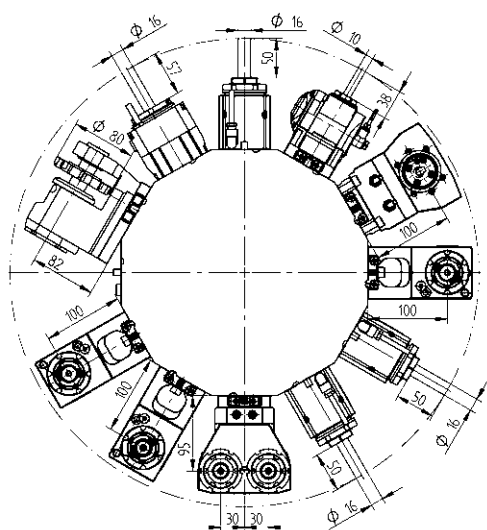

動力刀座 - QuickFlex® 產品目錄



直結式鑽/銑動力刀座 (6000 RPM)

ER-25 QF 420125010-30L 1:1 EC
440441W

0067725010

ER-25 QF 420125019-30L 1:1 IC 80 bar

0067725010



直結式鑽/銑動力刀座 (12000 RPM)

ER-25 QF 420125014-30L 1:1 EC

0067725010

ER-25 QF 420125015-30L 1:1 IC 80 bar

0067725010



直角式鑽/銑動力刀座, Trifix®, (6000 RPM)

ER-25 QF 420525055-30L 1:1 EC

0067725010

ER-25 QF 420525056-30L 1:1 IC 80 bar

0067725010



直角式鑽/銑動力刀座, Trifix®, (12000 RPM)

ER-25 QF 420525057-30L 1:1 EC

0067725010

ER-25 QF 420525058-30L 1:1 IC 80 bar

0067725010

動力刀座 - QuickFlex® 產品目錄



直角式鑽/銑動力刀座, Trifix®, (6000 RPM)

ER-25 QF 420525055-30R 1:1 EC

0067725010

ER-25 QF 420525056-30R 1:1 IC 80 bar

0067725010



直角式鑽/銑動力刀座, Trifix®, (12000 RPM)

ER-25 QF 420525057-30R 1:1 EC

0067725010

ER-25 QF 420525058-30R 1:1 IC 80 bar

0067725010



直角後縮式鑽/銑動力刀座, Trifix®, (6000 RPM)

ER-25 QF 420525089-30L 1:1 EC

0067725010

ER-25 QF 420525090-30L 1:1 IC 80 bar

0067725010



直角後縮式鑽/銑動力刀座, Trifix®, (12000 RPM)

ER-25 QF 420525060-30L 1:1 EC

0067725010

ER-25 QF 420525061-30L 1:1 IC 80 bar

0067725010

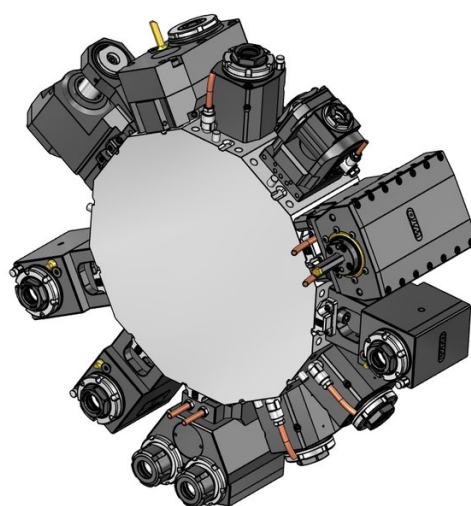
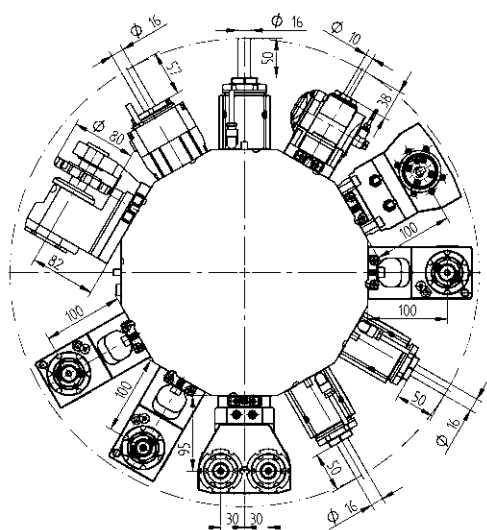

動力刀座 - QuickFlex® 產品目錄

- 直角後縮式鑽/銑動力刀座, Trifix®, (6000 RPM)
- | | | | |
|-----------------|---------------|-----|-----------|
| ER-25 QF | 420525089-30R | 1:1 | EC |
| | 0067725010 | | |
| ER-25 QF | 420525090-30R | 1:1 | IC 80 bar |
| | 0067725010 | | |

- 直角後縮式鑽/銑動力刀座, Trifix®, (12000 RPM)
- | | | | |
|-----------------|---------------|-----|-----------|
| ER-25 QF | 420525060-30R | 1:1 | EC |
| | 0067725010 | | |
| ER-25 QF | 420525061-30R | 1:1 | IC 80 bar |
| | 0067725010 | | |

- 直角式鑽/銑動力刀座, 正主軸及副主軸加工用, Trifix®, (6000 RPM)
- | | | | |
|-----------------|--------------|-----|----|
| ER-25 QF | 420525086-30 | 1:1 | EC |
| | 0067725010 | | |

- 直角式鑽/銑動力刀座, 正主軸及副主軸加工用, Trifix®, (12000 RPM)
- | | | | |
|-----------------|--------------|-----|----|
| ER-25 QF | 420525095-30 | 1:1 | EC |
| | 0067725010 | | |

動力刀座 - 進階產品目錄

- 直結式鑽/銑動力刀座 - BMT
- | | | | |
|-----------------|--------------|-----|-----------|
| ER-32 QF | 420132010-30 | 1:1 | EC |
| | 0067732000 | | |
| ER-32 QF | 420132011-30 | 1:1 | IC 80 bar |
| | 0067732000 | | |

- 直結式銑刀座
- | | | | |
|-------------|--------------|-----|----|
| Ø 16 | 410216014-30 | 1:1 | EC |
| | 00675000854 | | |

- 直結偏位式鑽/銑動力刀座
- | | | | |
|--------------|--------------|-----|-----------|
| ER 25 | 410116058-30 | 1:1 | EC |
| | 00675000801 | | |
| ER 25 | 410116057-30 | 1:1 | IC 80 bar |
| | 00675000801 | | |
| ER 20 | 410113010-30 | 1:2 | EC |
| | 00675000591 | | |
| ER 20 | 410113009-30 | 1:2 | IC 80 bar |
| | 00675000591 | | |
| ER 25 | 410116059-30 | 2:1 | EC |
| | 00675000801 | | |
| ER 25 | 410116060-30 | 2:1 | IC 80 bar |
| | 00675000801 | | |
| ER 32 | 410120027-30 | 2:1 | EC |
| | 00675000592 | | |
| ER 32 | 410120032-30 | 2:1 | IC 80 bar |
| | 00675000592 | | |

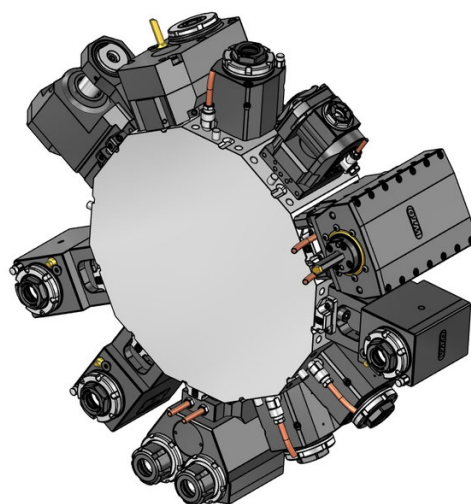
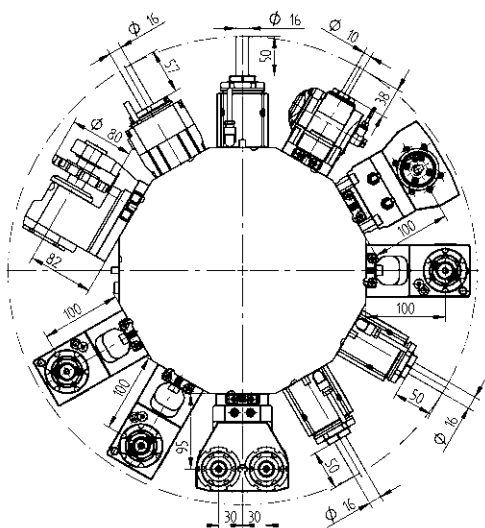

動力刀座 - 進階產品目錄

- 

直結偏位式鑽/銑動力刀座 - VDI 雙面排齒

ER 16	410410002-30	1:3	EC
	 00675000937		
ER 16	410410001-30	1:3	IC 80 bar
	 00675000937		

- 

直角式鑽/銑動力刀座

ER-20 QF	420520013-30	1:2	EC
	 0067720011		
ER-20 QF	420520014-30	1:2	IC 80 bar
	 0067720011		
ER 16	410810012-30	1:3	EC
	 00675000841		
ER 16	410810013-30	1:3	IC 80 bar
	 00675000841		
ER-25 QF	420525096-30	2:1	EC
	 0067725010		
ER-25 QF	420525097-30	2:1	IC 80 bar
	 0067725010		

- 

直角式鑽/銑動力刀座, Trifix®

ER-20 QF	420520015-30L	1:2	EC
	 0067720011		
ER-20 QF	420520016-30L	1:2	IC 80 bar
	 0067720011		

動力刀座 - 進階產品目錄

- 

直角後縮式鑽/銑動力刀座

ER 32	410520013-30	2:1	EC
	 00675000592		
ER 32	410520014-30	2:1	IC 80 bar
	 00675000592		

- 

可調角度鑽/銑動力刀座

ER 16	411010015-30	1:1	EC
	 00675000902		
ER 16	411010016-30	1:1	IC 80 bar
	 00675000902		
ER 11	411007018-30	1:2	EC
	 00675000914		
ER 11	411007019-30	1:2	IC 80 bar
	 00675000914		

- 

圓鋸開槽銑刀刀座

14-2 型式	410900015-30	2,615:1EC
	 00675000460	
	 160016142 Ø 16	
	 160022142 Ø 22	
	 160027142 Ø 27	
	 160015142 Ø 5/8"	
	 160019142 Ø 3/4"	
	 160023142 Ø 7/8"	
	 160025142 Ø 1"	

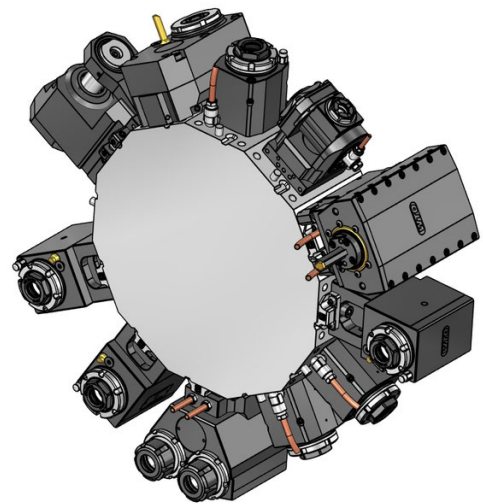
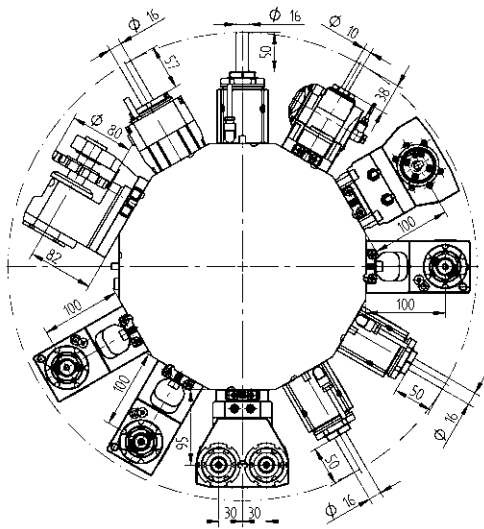

動力刀座 - 進階產品目錄

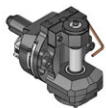

滾齒刀座, Trifix®

- | | | | |
|----------------|------------------|-----|----|
| 15-2 型式 | 410900025-30 | 1:1 | EC |
| | 00675001015 | | |
| | 160008152 Ø 8 | | |
| | 160010152 Ø 10 | | |
| | 160013152 Ø 13 | | |
| | 160016152 Ø 16 | | |
| | 160022152 Ø 22 | | |
| | 160015152 Ø 5/8" | | |
| | 160019152 Ø 3/4" | | |
| | 110587 | | |

動力刀座 - 進階產品目錄

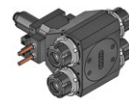

二軸直角鑽/銑動力刀座, 正主軸及副主軸加工用, Y-軸

- | | | | |
|--------------|--------------|-----|----|
| ER 25 | 413502009-30 | 1:1 | EC |
| | 00675000915 | | |



刨削刀座 (內外徑通用), Trifix® - BMT

- | | | | |
|--------------|---------------|-----|----|
| 32 型式 | 414532001-30L | 1:1 | EC |
|--------------|---------------|-----|----|



刨削刀座 (內外徑通用), Trifix® - BMT

- | | | | |
|--------------|---------------|-----|----|
| 32 型式 | 414532001-30R | 1:1 | EC |
|--------------|---------------|-----|----|



直結式鑽/銑刀座, 2刀位, Y-軸

- | | | | |
|--------------|--------------|-------|-----------|
| ER 25 | 413002008-30 | 1:1,5 | EC |
| | 00675000930 | | |
| ER 25 | 413002009-30 | 1:1,5 | IC 80 bar |
| | 00675000930 | | |



二軸直角鑽/銑動力刀座, Y-軸

- | | | | |
|--------------|--------------|-----|-----------|
| ER 25 | 413502000-30 | 1:1 | EC |
| | 00675000915 | | |
| ER 25 | 413502004-30 | 1:1 | IC 80 bar |
| | 00675000915 | | |

標準減徑套 - 圓柱形



變徑套 Ø 20

240020006	ø 6
240020008	ø 8
240020010	ø 10
240020012	ø 12
240020014	ø 14
240020016	ø 16



變徑套 Ø 25

240025006	ø 6
240025008	ø 8
240025010	ø 10
240025012	ø 12
240025014	ø 14
240025016	ø 16
240025020	ø 20



變徑套 Ø 32

240032006	ø 6
240032008	ø 8
240032010	ø 10
240032012	ø 12
240032014	ø 14
240032016	ø 16
240032018	ø 18
240032020	ø 20
240032025	ø 25



變徑套 Ø 40

240040006	ø 6
240040008	ø 8
240040010	ø 10
240040012	ø 12
240040014	ø 14
240040016	ø 16
240040020	ø 20
240040025	ø 25
240040032	ø 32



變徑套 Ø 50

240050010	ø 10
240050012	ø 12
240050016	ø 16
240050020	ø 20
240050025	ø 25
240050032	ø 32
240050040	ø 40

標準減徑套 - 圓柱形, 開槽



變徑套 Ø 25

240125006	ø 6
240125008	ø 8
240125010	ø 10
240125012	ø 12
240125014	ø 14
240125015	ø 15
240125016	ø 16
240125020	ø 20



變徑套 Ø 32

240132008	ø 8
240132010	ø 10
240132012	ø 12
240132015	ø 15
240132016	ø 16
240132020	ø 20
240132025	ø 25



變徑套 Ø 40

240140010	ø 10
240140012	ø 12
240140015	ø 15
240140016	ø 16
240140020	ø 20
240140025	ø 25
240140032	ø 32

標準減徑套 - 莫氏錐度



變徑套 Ø 32

240532001	MT 1
240532002	MT 2
240532003	MT 3

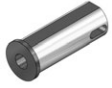

變徑套 Ø 40

240540001	MT 1
240540002	MT 2
240540003	MT 3
240540004	MT 4

筒夾 DIN 6499B (ER/ESX)



ER 11

190011000	ø 7-0.5	ø 0.276-0.020
190011010	ø 1-0.5	ø 0.039-0.020
190011015	ø 1.5-1	ø 0.059-0.039
190011020	ø 2-1.5	ø 0.079-0.059
190011025	ø 2.5-2	ø 0.098-0.079
190011030	ø 3-2.5	ø 0.118-0.098
190011035	ø 3.5-3	ø 0.138-0.118
190011040	ø 4-3.5	ø 0.158-0.138
190011045	ø 4.5-4	ø 0.177-0.158
190011050	ø 5-4.5	ø 0.197-0.177
190011055	ø 5.5-5	ø 0.217-0.197
190011060	ø 6-5.5	ø 0.236-0.217
190011065	ø 6.5-6	ø 0.256-0.236
190011070	ø 7-6.5	ø 0.276-0.256



ER 16

190016000	ø 10-0.5	ø 0.394-0.020
190016010	ø 1-0.5	ø 0.039-0.020
190016020	ø 2-1	ø 0.079-0.039
190016030	ø 3-2	ø 0.118-0.079
190016040	ø 4-3	ø 0.158-0.118
190016050	ø 5-4	ø 0.197-0.158
190016060	ø 6-5	ø 0.236-0.197
190016070	ø 7-6	ø 0.276-0.236
190016080	ø 8-7	ø 0.315-0.276
190016090	ø 9-8	ø 0.354-0.315
190016100	ø 10-9	ø 0.394-0.354



ER 20

190020000	ø 13-1	ø 0.512-0.039
190020010	ø 1-0.5	ø 0.039-0.020
190020020	ø 2-1	ø 0.079-0.039
190020030	ø 3-2	ø 0.118-0.079
190020040	ø 4-3	ø 0.157-0.118
190020050	ø 5-4	ø 0.197-0.157
190020060	ø 6-5	ø 0.236-0.197
190020070	ø 7-6	ø 0.276-0.236
190020080	ø 8-7	ø 0.315-0.276
190020090	ø 9-8	ø 0.354-0.315
190020100	ø 10-9	ø 0.394-0.354
190020110	ø 11-10	ø 0.433-0.394
190020120	ø 12-11	ø 0.472-0.433
190020130	ø 13-12	ø 0.512-0.472

筒夾 DIN 6499B (ER/ESX)



ER 25

190025000	ø 16-1	ø 0.630-0.039
190025010	ø 1-0.5	ø 0.039-0.020
190025020	ø 2-1	ø 0.079-0.039
190025030	ø 3-2	ø 0.118-0.079
190025040	ø 4-3	ø 0.157-0.118
190025050	ø 5-4	ø 0.197-0.157
190025060	ø 6-5	ø 0.236-0.197
190025070	ø 7-6	ø 0.276-0.236
190025080	ø 8-7	ø 0.315-0.276
190025090	ø 9-8	ø 0.354-0.315
190025100	ø 10-9	ø 0.394-0.354
190025110	ø 11-10	ø 0.433-0.394
190025120	ø 12-11	ø 0.472-0.433
190025130	ø 13-12	ø 0.512-0.472
190025140	ø 14-13	ø 0.551-0.512
190025150	ø 15-14	ø 0.591-0.551
190025160	ø 16-15	ø 0.630-0.591



ER 32

190032000	ø 20-2	ø 0.787-0.079
190032020	ø 2-1	ø 0.079-0.039
190032030	ø 3-2	ø 0.118-0.079
190032040	ø 4-3	ø 0.157-0.118
190032050	ø 5-4	ø 0.197-0.157
190032060	ø 6-5	ø 0.236-0.197
190032070	ø 7-6	ø 0.276-0.236
190032080	ø 8-7	ø 0.315-0.276
190032090	ø 9-8	ø 0.354-0.315
190032100	ø 10-9	ø 0.394-0.354
190032110	ø 11-10	ø 0.433-0.394
190032120	ø 12-11	ø 0.472-0.433
190032130	ø 13-12	ø 0.512-0.472
190032140	ø 14-13	ø 0.551-0.512
190032150	ø 15-14	ø 0.591-0.551
190032160	ø 16-15	ø 0.630-0.591
190032170	ø 17-16	ø 0.669-0.630
190032180	ø 18-17	ø 0.709-0.669
190032190	ø 19-18	ø 0.748-0.709
190032200	ø 20-19	ø 0.787-0.748

筒夾 DIN 6499B (ER/ESX)



ER 40

190040000	ø 26-3	ø 1.024-0.118
190040030	ø 3-2	ø 0.118-0.079
190040040	ø 4-3	ø 0.157-0.118
190040050	ø 5-4	ø 0.197-0.157
190040060	ø 6-5	ø 0.236-0.197
190040070	ø 7-6	ø 0.276-0.236
190040080	ø 8-7	ø 0.315-0.276
190040090	ø 9-8	ø 0.354-0.315
190040100	ø 10-9	ø 0.394-0.354
190040110	ø 11-10	ø 0.433-0.394
190040120	ø 12-11	ø 0.472-0.433
190040130	ø 13-12	ø 0.512-0.472
190040140	ø 14-13	ø 0.551-0.512
190040150	ø 15-14	ø 0.591-0.551
190040160	ø 16-15	ø 0.630-0.591
190040170	ø 17-16	ø 0.669-0.630
190040180	ø 18-17	ø 0.709-0.669
190040190	ø 19-18	ø 0.748-0.709
190040200	ø 20-19	ø 0.787-0.748
190040210	ø 21-20	ø 0.827-0.787
190040220	ø 22-21	ø 0.866-0.827
190040230	ø 23-22	ø 0.906-0.866
190040240	ø 24-23	ø 0.945-0.906
190040250	ø 25-24	ø 0.984-0.945
190040260	ø 26-25	ø 1.024-0.984



ER 50

190050000	ø 34-10	ø 1.339-0.394
190050060	ø 6-4	ø 0.236-0.157
190050080	ø 8-6	ø 0.315-0.236
190050100	ø 10-8	ø 0.394-0.315
190050120	ø 12-10	ø 0.472-0.394
190050140	ø 14-12	ø 0.551-0.472
190050160	ø 16-14	ø 0.630-0.551
190050180	ø 18-16	ø 0.709-0.630
190050200	ø 20-18	ø 0.787-0.709
190050220	ø 22-20	ø 0.866-0.787
190050240	ø 24-22	ø 0.945-0.866
190050260	ø 26-24	ø 1.024-0.945
190050280	ø 28-26	ø 1.102-1.024
190050300	ø 30-28	ø 1.181-1.102
190050320	ø 32-30	ø 1.260-1.181
190050340	ø 32-30	ø 1.260-1.181

筒夾 DIN 6499D (ER/ESX) - 密封, 中心出水用



ER 11

191011030	ø 3
191011040	ø 4
191011050	ø 5
191011060	ø 6



ER 16

191016000	ø 3-10
191016030	ø 3
191016040	ø 4
191016050	ø 5
191016060	ø 6
191016070	ø 7
191016080	ø 8
191016090	ø 9
191016100	ø 10



ER 20

191020000	ø 3-12
191020030	ø 3
191020040	ø 4
191020050	ø 5
191020060	ø 6
191020070	ø 7
191020080	ø 8
191020090	ø 9
191020100	ø 10
191020110	ø 11
191020120	ø 12



ER 25

191025000	ø 4-16
191025030	ø 3
191025040	ø 4
191025050	ø 5
191025060	ø 6
191025070	ø 7
191025080	ø 8
191025090	ø 9
191025100	ø 10
191025110	ø 11
191025120	ø 12
191025130	ø 13
191025140	ø 14
191025150	ø 15
191025160	ø 16

筒夾 DIN 6499D (ER/ESX) - 密封, 中心出水
用

ER 32

191032000	ø 4-20
191032030	ø 3
191032040	ø 4
191032050	ø 5
191032060	ø 6
191032070	ø 7
191032080	ø 8
191032090	ø 9
191032100	ø 10
191032110	ø 11
191032120	ø 12
191032130	ø 13
191032140	ø 14
191032150	ø 15
191032160	ø 16
191032170	ø 17
191032180	ø 18
191032190	ø 19
191032200	ø 20



ER 40

191040060	ø 6
191040080	ø 8
191040100	ø 10
191040120	ø 12
191040140	ø 14
191040160	ø 16
191040180	ø 18
191040200	ø 20
191040220	ø 22
191040250	ø 25

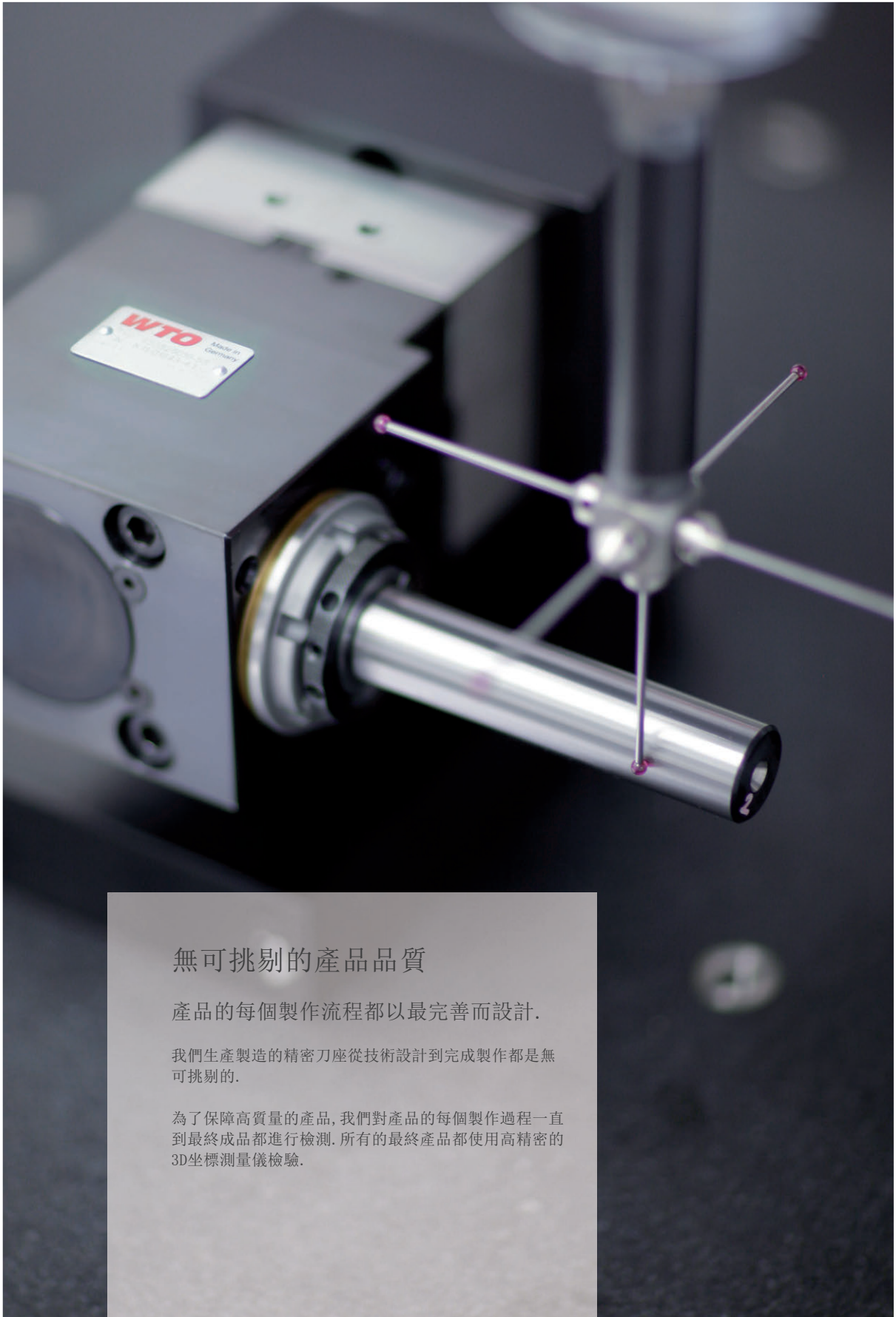

無可挑剔的產品品質

產品的每個製作流程都以最完善而設計。

我們生產製造的精密刀座從技術設計到完成製作都是無可挑剔的。

為了保障高質量的產品，我們對產品的每個製作過程一直到最終成品都進行檢測。所有的最終產品都使用高精密的3D坐標測量儀檢驗。



WTO
Werkzeug-
Einrichtungen GmbH 德國
Neuer Hohdammweg 1
77797 Ohlsbach
德國

WTO Inc. 美國
13900-F South Lakes Dr.
Charlotte, NC 28273
美國

WTO 亞洲
WTO Precision Tool Holders
(Shanghai) Co. Ltd.
Room 109-110, Building 2
No. 228 Banting Road
Jiuting Town,
Songjiang District
201615 Shanghai
中國

我們的全球合作夥伴. 提供充分的技術及服務

澳大利亞
Dimac Tooling Ltd.
sales@dimac.com.au

英國
Cutwel Ltd.
sales@cutwel.net

韓國
WTO Office Korea
is.chon@wto-korea.com

瑞士
Utilis AG
info@utilis.com

巴西
TF2
tfdois@tfdois.com.br

匈牙利
Prevotex Hungary Kft.
info@prevotex.hu

墨西哥
Workholding Engineering De México
info@wem.com.mx

斯洛伐克
ALBA precision s.r.o.
albabprecision@albabprecision.sk

中國
Shanghai Gangde
wtocando@yahoo.com

印度
Ulhas Patil
u.patil@wto-asia.com

荷蘭
Toologic BeNeLux B.V.
info@toologic-benelux.nl

西班牙
ITALMATIC, S.A.
italmatic@italmatic.es

丹麥
AVN Teknik A/S
cjo@avn.dk

以色列
E.Y.A.R. Ltd.
boris@eyar.co.il

挪威
Helge Karlsen Verktøy og Maskin AS
hkvm@hkvm.no

台灣
Kaiko Co., Ltd.
info@kaiko.com.tw

芬蘭
Suomen Terästuonti Oy
myynti@stt.as

意大利
Prymark srl
commerciale@prymark.it

波蘭
ARCO Andrzej Rudenko
info@arcotools.pl

土耳其
MYK CNC MAKINA SAN. VE
huseyin.tatlidil@mykcnc.com.tr

法國, 東部
Alexandre Mathelin
alm@wto.de

日本
NK Works Co. Ltd.
k_samba@nk-works.co.jp

羅馬尼亞
SC Elif Trading SRL
bulent.ozkan@eliftrading.com

捷克
ALBA precision, spol. s.r.o.
info@albabprecision.cz

法國, 西部
Christophe Archambault
car@wto.de

加拿大
Mittmann Industrial Inc.
info@mittmann.com

瑞典
Bonhron & Ewing AB
info@bonhron-ewing.se

烏克蘭
„LLC“ SPA Stankopromimport
info@phoenix-ua.com