

DMG MORI

WTO

刀座产品目录

CLX/CTX 350 V3-V4, T1
CLX/CTX 350 V6
CLX/CTX 450/550 V3-V4, T2
CLX/CTX 450/550/750 V6
CTX 2500 V3-V4
CTX 2500 V6
Sprint 50
Sprint 65

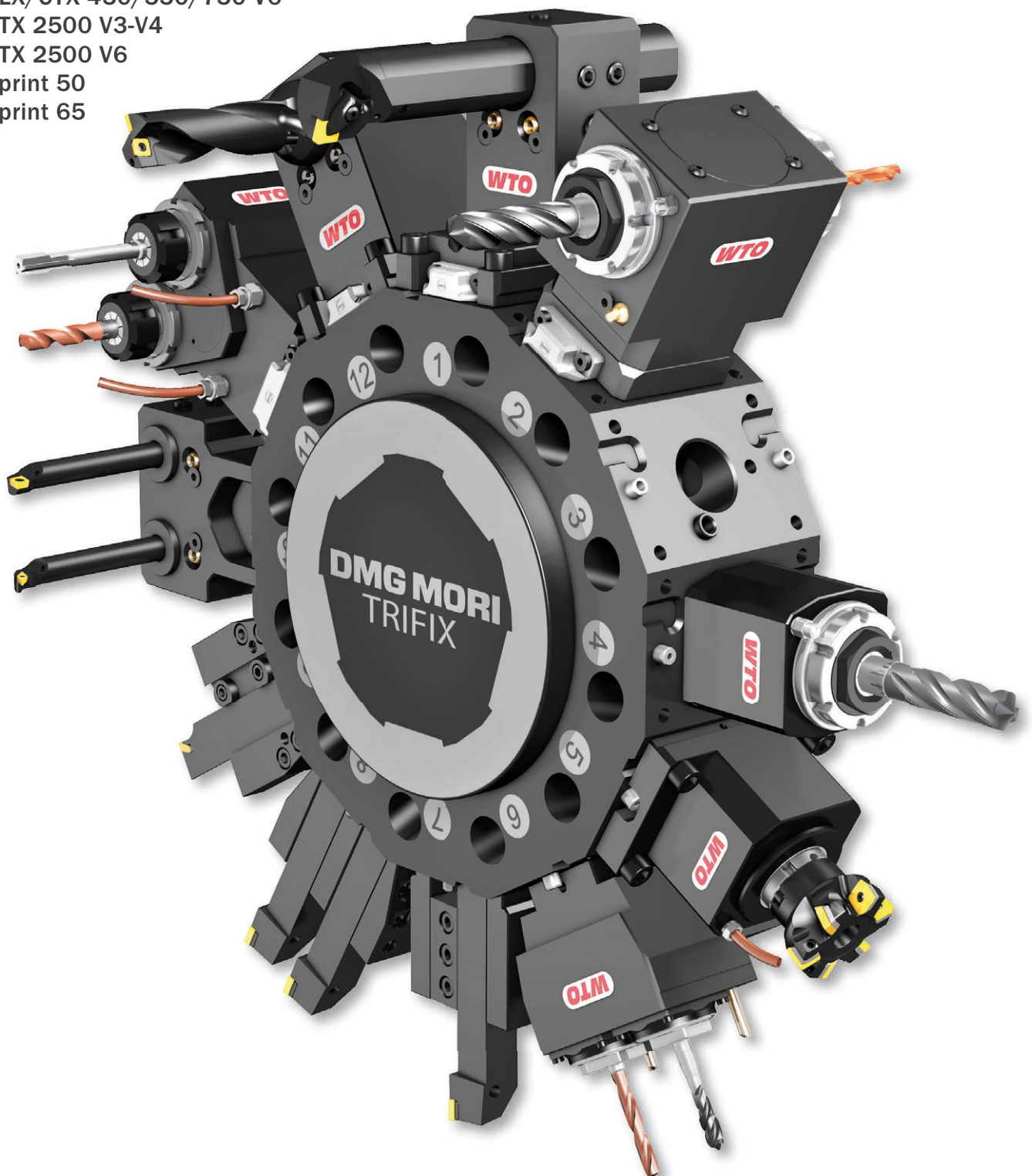

Trifix®



QuickFlex®

全新快换系统提供高效能和高精密度.

最小的投资, 最大的扩展性.

Trifix®

专用

| | | |
|---------------------------|---|---------|
| CLX/CTX 350 V3-V4, T1 | 页 | 4 - 6 |
| CLX/CTX 350 V6 | 页 | 7 - 13 |
| CLX/CTX 450/550 V3-V4, T2 | 页 | 14 - 17 |
| CLX/CTX 450/550/750 V6 | 页 | 18 - 26 |
| CTX 2500 V3-V4 | 页 | 27 - 30 |
| CTX 2500 V6 | 页 | 31 - 39 |
| Sprint 50 | 页 | 40 - 44 |
| Sprint 65 | 页 | 45 - 51 |
| 变径套 | 页 | 52 - 53 |
| 筒夹 | 页 | 54 - 56 |

EC = 外部切削液供应
HP-IC = 高压内部切削液供应通过切削工具
IC 80 bar = 内部+外部切削液供应
最高切削液压力 = 80 bar
IC 30 bar = 内部+外部切削液供应
最高切削液压力 = 30 bar
仅使用被滤网过的切削液(最大颗粒小于50 µm)
不开启冷却液, 刀座不能运行
不能对铸铁类材料加工, 如生铁等

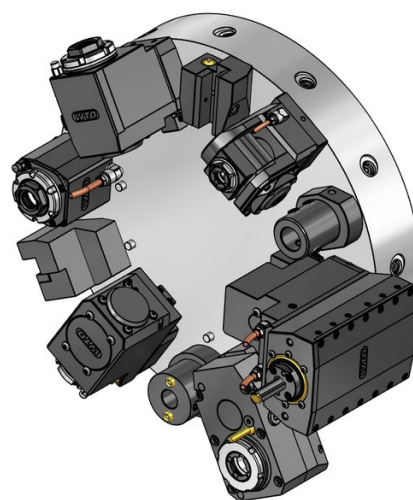
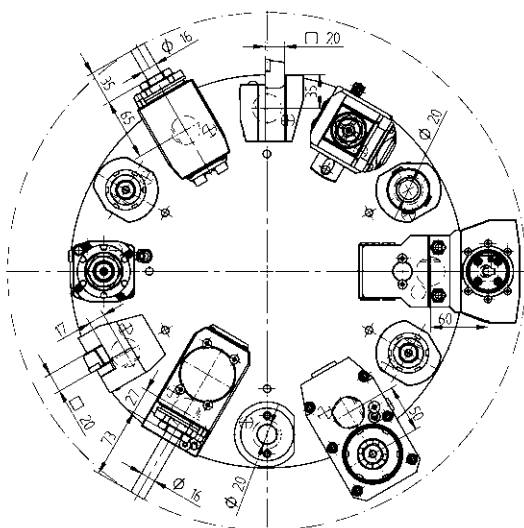

固定刀座 - 标准产品目录



20(16) 48-B1-30x20
20(16) 48-B1-30x20x60

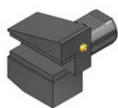

20(16) 48-B3-30x20



20(16) 48-B5-30x20



20(16) 48-B7-30x20



20 48-105980R-HP IC 80 bar
20 48-105980L-HP IC 80 bar



20(16) 48-C1-30x20



20(16) 48-C3-30x20

固定刀座 - 标准产品目录



| | | |
|-------|---------------|-----------|
| SH 26 | 48-102686R | IC 80 bar |
| | 343-810100R43 | |
| SH 26 | 48-102686L | IC 80 bar |
| | 343-810100L43 | |
| SH 32 | 48-102688R | IC 80 bar |
| SH 32 | 48-102688L | IC 80 bar |



| | |
|------|-------------|
| Ø 16 | 48-E1-30x16 |
| Ø 20 | 48-E1-30x20 |
| Ø 25 | 48-E1-30x25 |
| Ø 32 | 48-E1-30x32 |



| | |
|------|-------------|
| Ø 8 | 48-E2-30x8 |
| Ø 10 | 48-E2-30x10 |
| Ø 12 | 48-E2-30x12 |
| Ø 16 | 48-E2-30x16 |
| Ø 20 | 48-E2-30x20 |
| Ø 25 | 48-E2-30x25 |
| Ø 32 | 48-E2-30x32 |



| | |
|-------|-------------|
| ER 20 | 48-E4-30x20 |
| ER 25 | 48-E4-30x25 |
| | 107525000 |
| ER 32 | 48-E4-30x32 |
| | 107532000 |
| ER 40 | 48-E4-30x40 |
| | 107540000 |

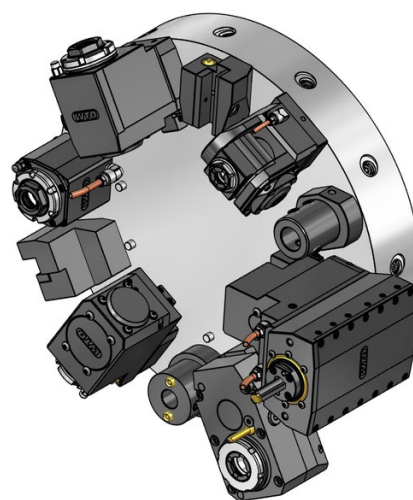
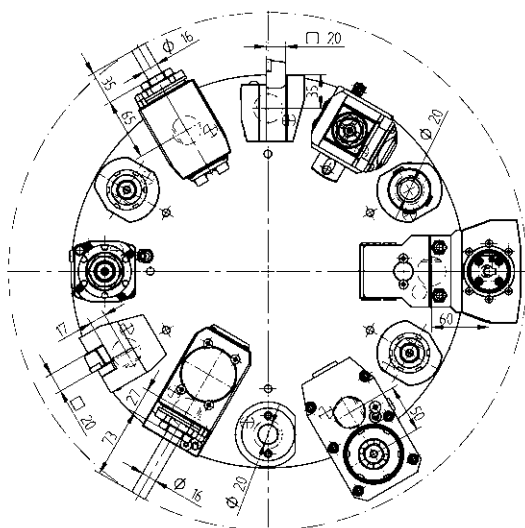

动力刀座 - QuickFlex®

-  直结式钻/铣动力刀座
- | | | | |
|----------|--|-----|-----------|
| ER-25 QF | 420125010-30R | 1:1 | EC |
| |  0067725010 | | |
| ER-25 QF | 420125019-30R | 1:1 | IC 80 bar |
| |  0067725010 | | |



-  直角式钻/铣动力刀座
- | | | | |
|----------|--|-----|-----------|
| ER-25 QF | 420525066-30R | 1:1 | EC |
| |  0067725010 | | |
| ER-25 QF | 420525067-30R | 1:1 | IC 80 bar |
| |  0067725010 | | |

-  直角后缩式钻/铣动力刀座
- | | | | |
|----------|--|-----|-----------|
| ER-25 QF | 420525062-30R | 1:1 | EC |
| |  0067725010 | | |
| ER-25 QF | 420525063-30R | 1:1 | IC 80 bar |
| |  0067725010 | | |

动力刀座 - 扩展产品目录

-  直结式铣刀座
- | | | | |
|------|--|-----|----|
| Ø 16 | 410216014-30 | 1:1 | EC |
| |  00675000854 | | |

-  直结偏位式钻/铣动力刀座
- | | | | |
|-------|---|-----|-----------|
| ER 25 | 410116094-30 | 1:1 | EC |
| |  00675000801 | | |
| ER 25 | 410116095-30 | 1:1 | IC 80 bar |
| |  00675000801 | | |
| ER 20 | 410113029-30 | 1:2 | EC |
| |  00675000591 | | |
| ER 20 | 410113030-30 | 1:2 | IC 80 bar |
| |  00675000591 | | |
| ER 32 | 410120035-30 | 2:1 | EC |
| |  00675000592 | | |
| ER 32 | 410120036-30 | 2:1 | IC 80 bar |
| |  00675000592 | | |

-  直结偏位式钻/铣动力刀座 - VDI两面齿轮
- | | | | |
|-------|---|-----|-----------|
| ER 16 | 410410002-30 | 1:3 | EC |
| |  00675000937 | | |
| ER 16 | 410410001-30 | 1:3 | IC 80 bar |
| |  00675000937 | | |

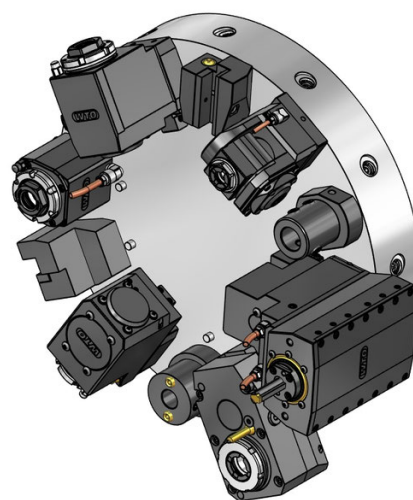
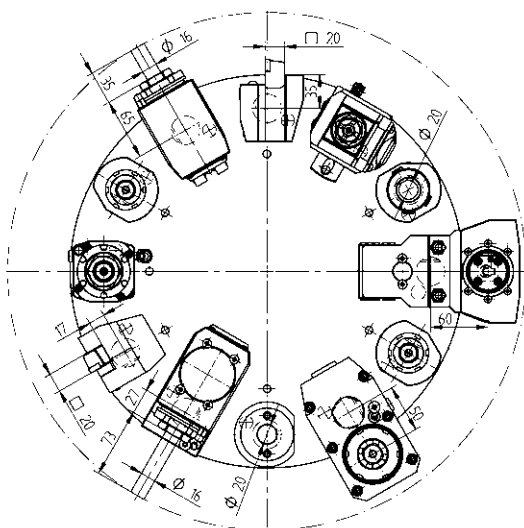

动力刀座 - 扩展产品目录



直角式钻/铣动力刀座

| | | | |
|----------|-----------------------------|-----|-----------|
| ER-20 QF | 420520011-30R 0067720011 | 1:2 | EC |
| ER-20 QF | 420520012-30R 0067720011 | 1:2 | IC 80 bar |
| ER-25 QF | 420525087-30R 0067725010 | 2:1 | EC |
| ER-25 QF | 420525088-30R 0067725010 | 2:1 | IC 80 bar |



直角后缩式钻/铣动力刀座

| | | | |
|-------|-----------------------------|-----|-----------|
| ER 25 | 410516136-30 00675000801 | 2:1 | EC |
| ER 25 | 410516137-30 00675000801 | 2:1 | IC 80 bar |



直角式铣动力刀座 - 组合铣刀心轴, DIN6358

| | | | |
|------|-----------------------------|-----|----|
| Ø 16 | 410616021-30 00675000854 | 1:1 | EC |
| Ø 22 | 410622011-30 00675000160 | 1:1 | EC |

动力刀座 - 扩展产品目录



可调角度钻/铣动力刀座

| | | | |
|-------|-----------------------------|-----|-----------|
| ER 16 | 411010003-30 00675000902 | 1:1 | EC |
| ER 16 | 411010004-30 00675000902 | 1:1 | IC 80 bar |
| ER 11 | 411007016-30 00675000914 | 1:2 | EC |
| ER 11 | 411007017-30 00675000914 | 1:2 | IC 80 bar |

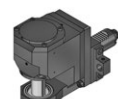

圆盘铣刀刀座

| | | | |
|---------|-----------------------------|---------|----|
| 14-2 型式 | 410900008-30 00675000460 | 2,615:1 | EC |
| | 160016142 Ø 16 | | |
| | 160022142 Ø 22 | | |
| | 160027142 Ø 27 | | |
| | 160015142 Ø 5/8" | | |
| | 160019142 Ø 3/4" | | |
| | 160023142 Ø 7/8" | | |
| | 160025142 Ø 1" | | |

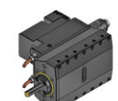

插槽刀座(内外径通用)

| | | | |
|-------|--------------|-----|----|
| 32 型式 | 414132000-30 | 1:1 | EC |
|-------|--------------|-----|----|

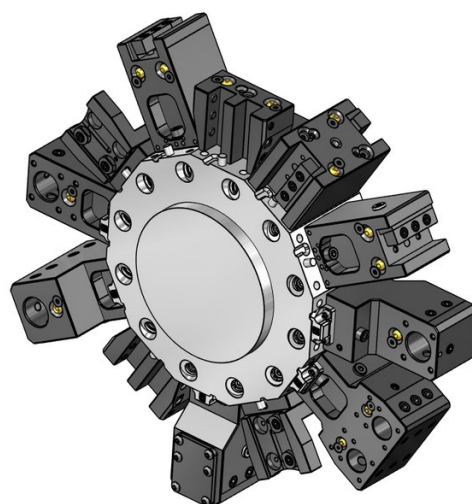
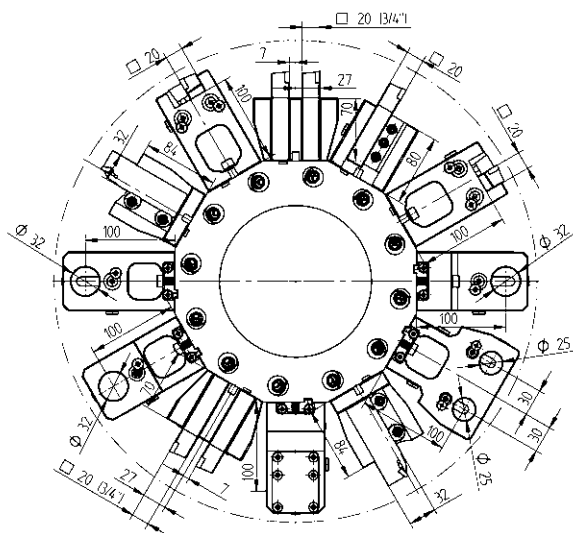

固定刀座 - 标准产品目录

- 

20(16) 方形刀柄轴向刀座, 右手刀, C1型式
48-C1-30x20
- 

20(16) 方形刀柄轴向刀座, 左手刀, C2型式
48-C2-30x20
- 

20(16) 方形刀柄轴向刀座, 右手反刀, C3型式
48-C3-30x20
- 

20(16) 方形刀柄轴向刀座, 左手反刀, C4型式
48-C4-30x20
- 

20(16) 方形刀柄刀座, D1 型式
48-D1-30x20
- 

20(16) 方形刀柄刀座, 反刀, D2 型式
48-D2-30x20
- 

20 车端面 and 车削刀座, 左手刀
48-71932
R4Z410W

固定刀座 - 标准产品目录

- 

20 车端面 and 车削刀座, 右手刀
48-72047
R4Z230W
- 

20 车端面 and 车削刀座, 两侧的
48-71216
R6Z410W
- 

20 车端面 and 镗削刀座
48-105756
- 

20 车端面 and 镗削刀座, Trifix®
48-109793
- 

Ø 32 组合刀座, 通用的, LF=100
48-71434
241132016 ER25
241132020 ER32
- 

Ø 32 组合刀座, 通用的, Trifix®, LF=100
48-96995
241132016 ER25
241132020 ER32

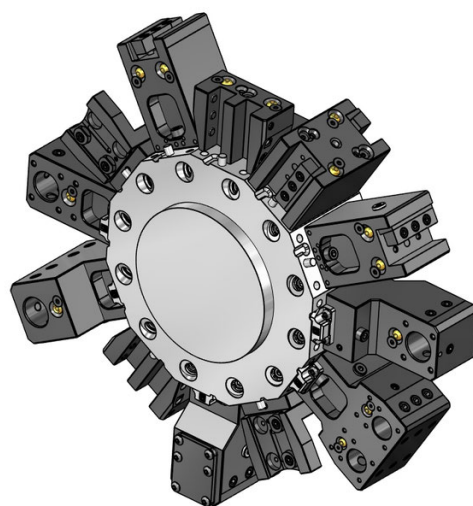
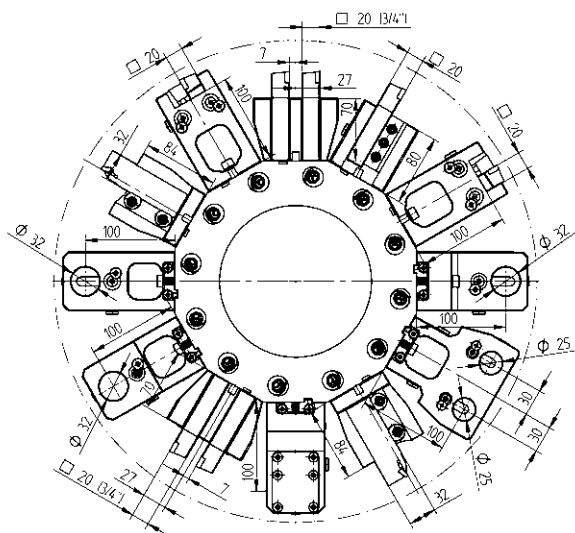

固定刀座 - 标准产品目录

- 

组合刀座, 后缩式, 左手刀, LF=100
 Ø 32 48-71438
 241132016 ER25
 241132020 ER32
- 

组合刀座, 后缩式, 左手刀, Trifix®, LF=100
 Ø 32 48-97531
 241132016 ER25
 241132020 ER32
- 

组合刀座, 后缩式, 右手刀, LF=100
 Ø 32 48-71436
 241132016 ER25
 241132020 ER32
- 

组合刀座, 后缩式, 右手刀, Trifix®, LF=100
 Ø 32 48-97553
 241132016 ER25
 241132020 ER32
- 

组合刀座, 两侧的, LF=100
 Ø 32 48-88781

固定刀座 - 标准产品目录

- 

组合刀座, 两侧的, Trifix®, LF=100
 Ø 32 48-97496
- 

筒夹刀座, LF=100
 ER 32 48-82824 IC 80 bar
 107532000
- 

筒夹刀座, Trifix®, LF=100
 ER 32 48-100198 IC 80 bar
 107532000
- 

筒夹刀座, 两侧的, LF=100
 ER 32 48-82847 IC 80 bar
 107532000
- 

筒夹刀座, 两侧的, Trifix®, LF=100
 ER 32 48-100199 IC 80 bar
 107532000

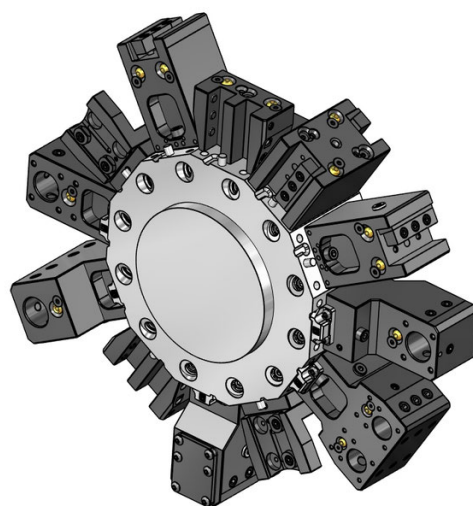
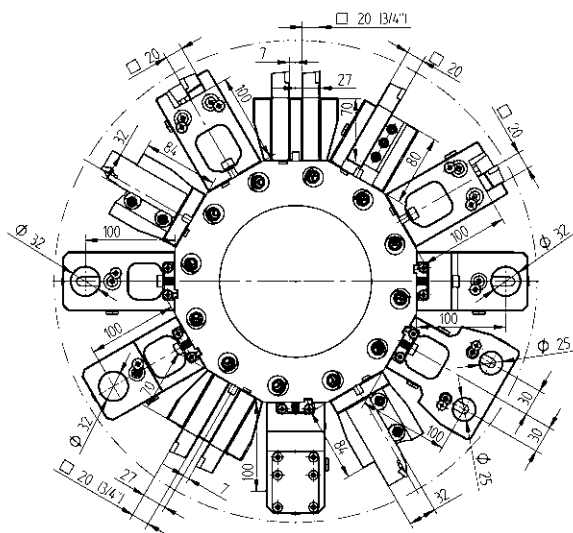

固定刀座 - 扩展产品目录

- 

端面车刀座, 高压内冷 - VDI两面齿
20 48-105977-HP IC 80 bar
- 

车端面和车削刀座, 两侧的, HP-IC
20 48-71216-HP IC 80 bar
- 

车端面和车削刀座, 2刀位, Y-轴 - VDI两面齿轮
20 (3/4") 48-84593
- 

车端面和车削刀座, 两侧的, 2刀位, Y-轴
20 (3/4") 48-77395
442750W
- 

切断刀用刀座, 可调节的 - VDI两面齿轮
SH 26 48-98991
R4Z451W
SH 32 48-99017
R9Z450
- 

切断刀用刀座, 可调节的, 内部切削液供应, HP-IC - VDI两面齿轮
SH 26 48-102630R IC 80 bar
343-810100R42
SH 26 48-102630L IC 80 bar
343-810100L42
SH 32 48-102632R IC 80 bar
SH 32 48-102632L IC 80 bar

固定刀座 - 扩展产品目录

- 

组合刀座, 通用的, Trifix®, LF=100 - BMT
Ø 40 48-99669
241140020 ER32
241140026 ER40
- 

镗刀刀座, 带槽, LF=100
Ø 32 48-87088
- 

镗刀刀座, 带槽, Trifix®, LF=100
Ø 32 48-97588
- 

镗刀刀座, 带槽, Trifix®, LF=100 - BMT
Ø 40 48-96994
- 

组合刀座, 通用的, 2刀位, Y-轴, LF=100
Ø 25 48-79026
241125016 ER25
- 

组合刀座, 通用的, 2刀位, Y-轴, LF=100, Trifix®
Ø 25 48-99635
241125016 ER25

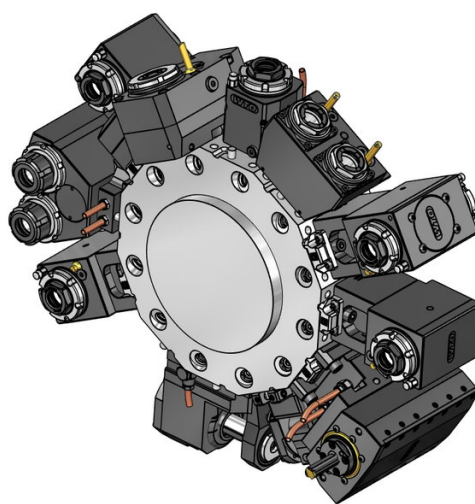
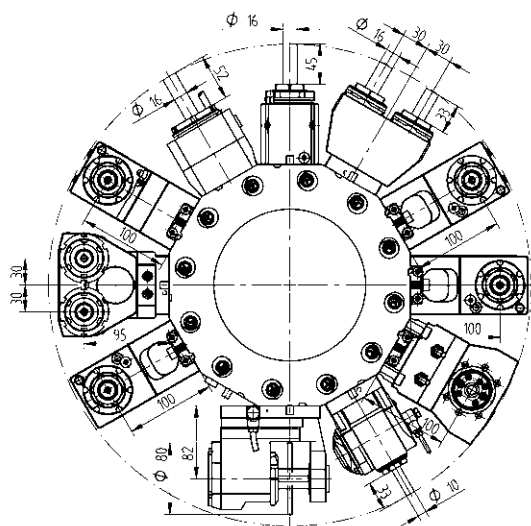

动力刀座 - QuickFlex®



直结式钻/铣动力刀座 (6000 RPM)

ER-25 QF 420125010-30L 1:1 EC
440441W



0067725010

ER-25 QF 420125019-30L 1:1 IC 80 bar



0067725010



直结式钻/铣动力刀座 (12000 RPM)

ER-25 QF 420125014-30L 1:1 EC

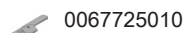

0067725010

ER-25 QF 420125015-30L 1:1 IC 80 bar

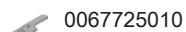

0067725010



直角式钻/铣动力刀座, Trifix®, (6000 RPM)

ER-25 QF 420525055-30L 1:1 EC

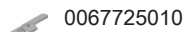

0067725010

ER-25 QF 420525056-30L 1:1 IC 80 bar

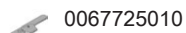

0067725010



直角式钻/铣动力刀座, Trifix®, (12000 RPM)

ER-25 QF 420525057-30L 1:1 EC



0067725010

ER-25 QF 420525058-30L 1:1 IC 80 bar

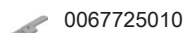

0067725010

动力刀座 - QuickFlex®



直角式钻/铣动力刀座, Trifix®, (6000 RPM)

ER-25 QF 420525055-30R 1:1 EC



0067725010

ER-25 QF 420525056-30R 1:1 IC 80 bar



0067725010



直角式钻/铣动力刀座, Trifix®, (12000 RPM)

ER-25 QF 420525057-30R 1:1 EC

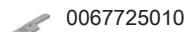

0067725010

ER-25 QF 420525058-30R 1:1 IC 80 bar

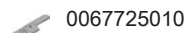

0067725010



直角后缩式钻/铣动力刀座, Trifix®, (6000 RPM)

ER-25 QF 420525089-30L 1:1 EC

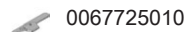

0067725010

ER-25 QF 420525090-30L 1:1 IC 80 bar

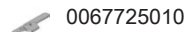

0067725010



直角后缩式钻/铣动力刀座, Trifix®, (12000 RPM)

ER-25 QF 420525060-30L 1:1 EC



0067725010

ER-25 QF 420525061-30L 1:1 IC 80 bar

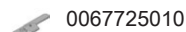

0067725010

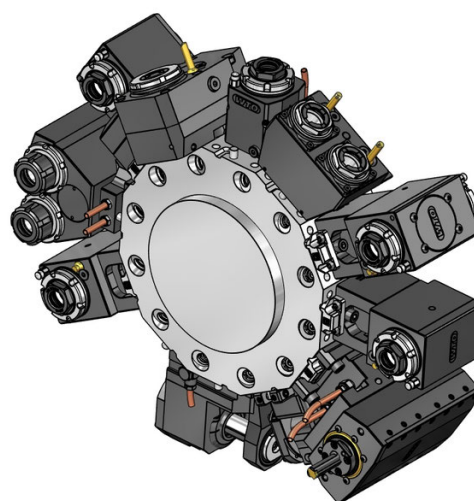
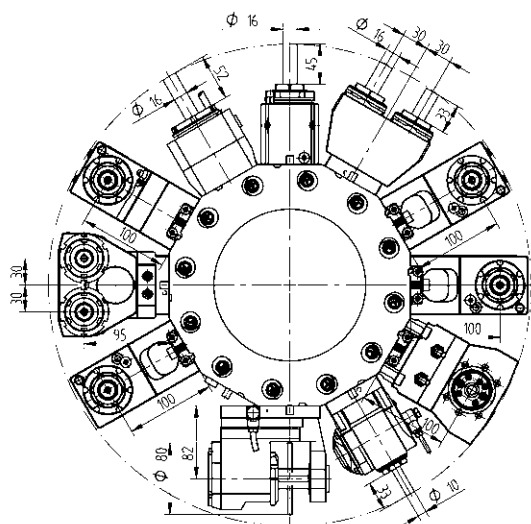

动力刀座 - QuickFlex®

动力刀座 - 扩展产品目录



直角后缩式钻/铣动力刀座, Trifix®, (6000 RPM)

ER-25 QF 420525089-30R 1:1 EC



ER-25 QF 420525090-30R 1:1 IC 80 bar



直角后缩式钻/铣动力刀座, Trifix®, (12000 RPM)

ER-25 QF 420525060-30R 1:1 EC

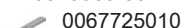

ER-25 QF 420525061-30R 1:1 IC 80 bar



直角式钻/铣动力刀座, 两侧的, Trifix®, (6000 RPM)

ER-25 QF 420525086-30 1:1 EC



直角式钻/铣动力刀座, 两侧的, Trifix®, (12000 RPM)

ER-25 QF 420525095-30 1:1 EC



直结式钻/铣动力刀座 - BMT

ER-32 QF 420132010-30 1:1 EC



ER-32 QF 420132011-30 1:1 IC 80 bar



直结式铣刀座

Ø 16 410216014-30 1:1 EC



直结偏位式钻/铣动力刀座

ER 25 410116058-30 1:1 EC



ER 25 410116057-30 1:1 IC 80 bar



ER 20 410113010-30 1:2 EC



ER 20 410113009-30 1:2 IC 80 bar



ER 25 410116059-30 2:1 EC



ER 25 410116060-30 2:1 IC 80 bar



ER 32 410120027-30 2:1 EC



ER 32 410120032-30 2:1 IC 80 bar



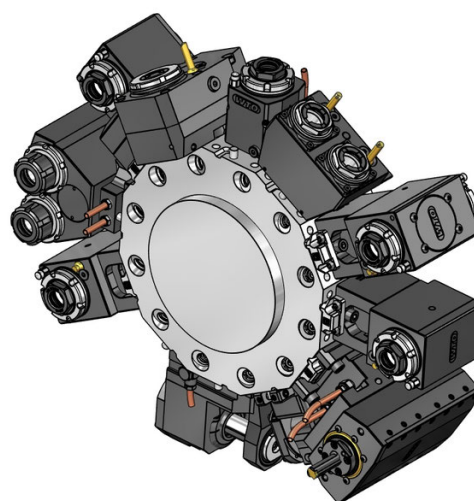
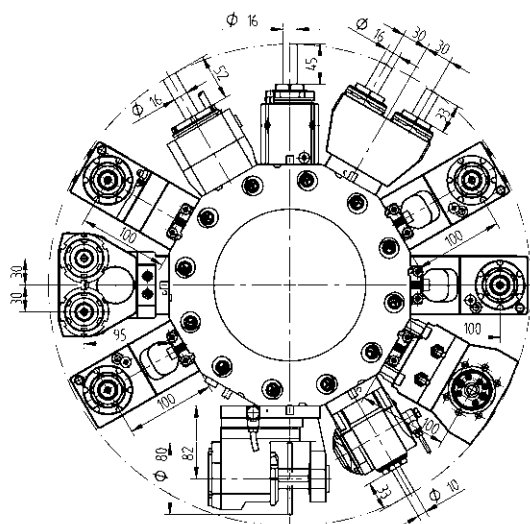

动力刀座 - 扩展产品目录

动力刀座 - 扩展产品目录



直结偏位式钻/铣动力刀座 - VDI两面齿轮

- | | | | |
|-------|--------------|-----|-----------|
| ER 16 | 410410002-30 | 1:3 | EC |
| | 00675000937 | | |
| ER 16 | 410410001-30 | 1:3 | IC 80 bar |
| | 00675000937 | | |



直角后缩式钻/铣动力刀座

- | | | | |
|-------|--------------|-----|-----------|
| ER 32 | 410520013-30 | 2:1 | EC |
| | 00675000592 | | |
| ER 32 | 410520014-30 | 2:1 | IC 80 bar |
| | 00675000592 | | |



直角式钻/铣动力刀座

- | | | | |
|----------|--------------|-----|-----------|
| ER-20 QF | 420520013-30 | 1:2 | EC |
| | 0067720011 | | |
| ER-20 QF | 420520014-30 | 1:2 | IC 80 bar |
| | 0067720011 | | |
| ER 16 | 410810012-30 | 1:3 | EC |
| | 00675000841 | | |
| ER 16 | 410810013-30 | 1:3 | IC 80 bar |
| | 00675000841 | | |
| ER-25 QF | 420525096-30 | 2:1 | EC |
| | 0067725010 | | |
| ER-25 QF | 420525097-30 | 2:1 | IC 80 bar |
| | 0067725010 | | |

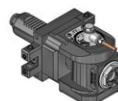

可调角度钻/铣动力刀座

- | | | | |
|-------|--------------|-----|-----------|
| ER 16 | 411010015-30 | 1:1 | EC |
| | 00675000902 | | |
| ER 16 | 411010016-30 | 1:1 | IC 80 bar |
| | 00675000902 | | |
| ER 11 | 411007018-30 | 1:2 | EC |
| | 00675000914 | | |
| ER 11 | 411007019-30 | 1:2 | IC 80 bar |
| | 00675000914 | | |



直角式钻/铣动力刀座, Trifix®

- | | | | |
|----------|---------------|-----|-----------|
| ER-20 QF | 420520015-30L | 1:2 | EC |
| | 0067720011 | | |
| ER-20 QF | 420520016-30L | 1:2 | IC 80 bar |
| | 0067720011 | | |



圆盘铣刀刀座

- | | | |
|---------|------------------|-----------|
| 14-2 型式 | 410900015-30 | 2,615:1EC |
| | 00675000460 | |
| | 160016142 Ø 16 | |
| | 160022142 Ø 22 | |
| | 160027142 Ø 27 | |
| | 160015142 Ø 5/8" | |
| | 160019142 Ø 3/4" | |
| | 160023142 Ø 7/8" | |
| | 160025142 Ø 1" | |

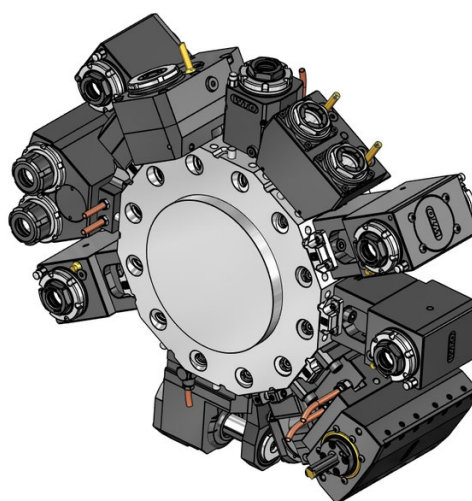
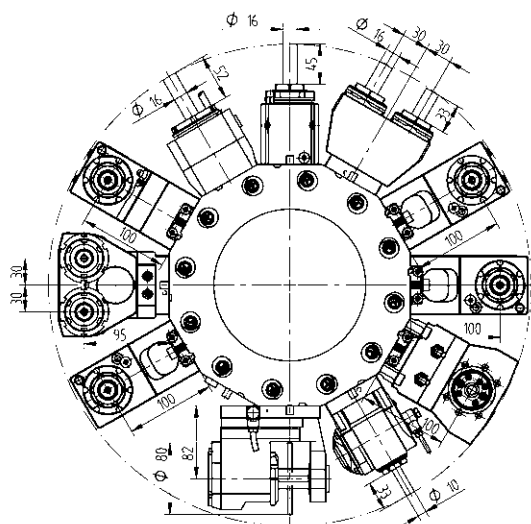

动力刀座 - 扩展产品目录

动力刀座 - 扩展产品目录



滚齿刀座, Trifix®

15-2 型式 410900025-30 1:1 EC

00675001015

160008152 Ø 8

160010152 Ø 10

160013152 Ø 13

160016152 Ø 16

160022152 Ø 22

160015152 Ø 5/8"

160019152 Ø 3/4"

110587

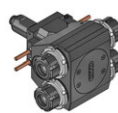

二轴直角式钻/铣动力刀座, 两侧的, Y-轴

ER 25 413502009-30 1:1 EC

00675000915



插槽刀座 (内外径通用), Trifix® - BMT

32 型式 414532001-30L 1:1 EC



插槽刀座 (内外径通用), Trifix® - BMT

32 型式 414532001-30R 1:1 EC



直结式钻/铣刀座, 2刀位, Y-轴

ER 25 413002008-30 1:1,5 EC

00675000930

ER 25 413002009-30 1:1,5 IC 80 bar

00675000930



二轴直角式钻/铣动力刀座, Y-轴

ER 25 413502000-30 1:1 EC

00675000915

ER 25 413502004-30 1:1 IC 80 bar

00675000915

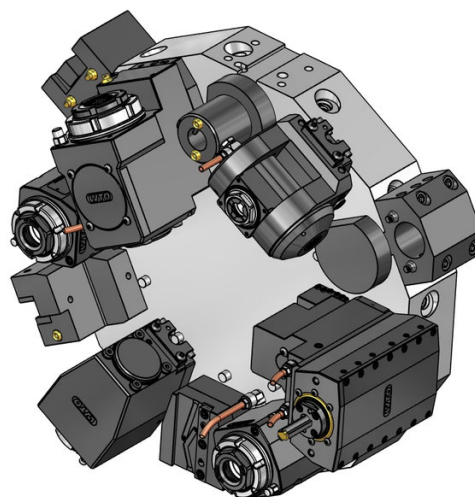
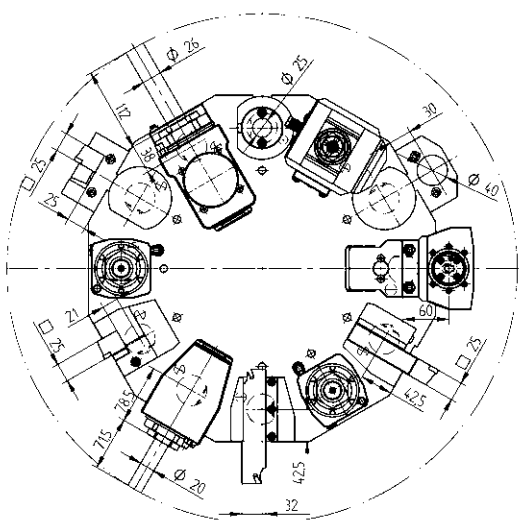

固定刀座 - 标准产品目录

固定刀座 - 标准产品目录



车端面和镗削刀座

25 48-PU2-25-25



组合刀座

Ø 20 48-PU1-25-20 IC 80 bar
 Ø 25 48-PU1-25-25 IC 80 bar
 Ø 32 48-PU1-25-32 IC 80 bar
 Ø 40 48-PU1-25-40 IC 80 bar
 Ø 50 48-PU1-25-50 IC 80 bar



VDI适配器, 右手刀

VDI 40 48-99856



径向右手方形刀座, 短型, B1型式

25(20) 48-B1-40x25

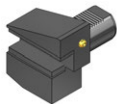

径向右手方形刀座, 反刀, 短型, B3型式

25(20) 48-B3-40x25



径向右手方形刀座, 长型, B5型式

25(20) 48-B5-40x25



径向右手方形刀座, 反刀, 长型, B7型式

25(20) 48-B7-40x25



径向方形刀座, HP-IC - VDI两面齿轮

25 48-105989R-HP IC 80 bar
 25 48-102790L-HP IC 80 bar

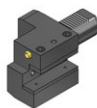

方形刀柄轴向刀座, 右手刀, C1型式

25(20) 48-C1-40x25



方形刀柄轴向刀座, 右手反刀, C3型式

25(20) 48-C3-40x25



切断刀用刀座, 高度可调整, 右手刀

SH 26 48-AR-40x26
 SH 32 48-AR-40x32



切断刀用刀座, 高度可调整, 右手反刀

SH 26 48-ARU-40x26



切断刀用刀座, 高度可调整, 内部切削液供应

SH 32 48-102690R IC 80 bar
 SH 32 48-102690L IC 80 bar

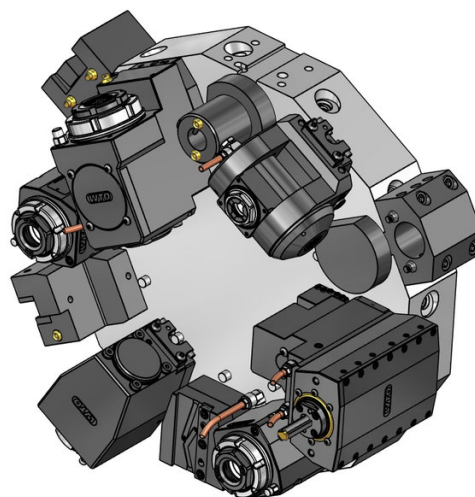
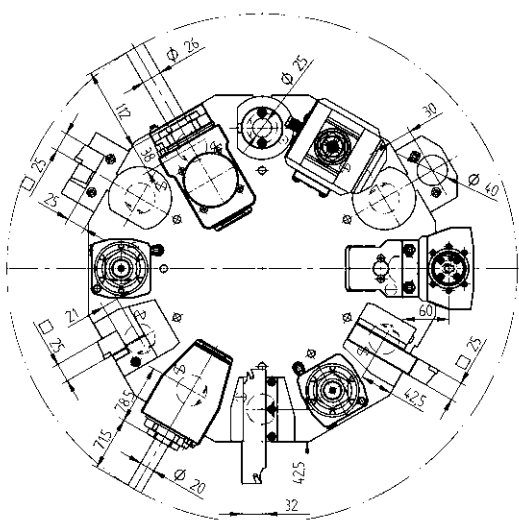

固定刀座 - 标准产品目录



可转位式钻头座, 内部切削液供应, E1型式

- Ø 16 48-E1-40x16
- Ø 20 48-E1-40x20
- Ø 25 48-E1-40x25
- Ø 32 48-E1-40x32
- Ø 40 48-E1-40x40



镗刀刀座, 内部切削液供应, E2型式

- Ø 8 48-E2-40x8
- Ø 10 48-E2-40x10
- Ø 12 48-E2-40x12
- Ø 16 48-E2-40x16
- Ø 20 48-E2-40x20
- Ø 25 48-E2-40x25
- Ø 30 48-E2-40x30
- Ø 32 48-E2-40x32
- Ø 40 48-E2-40x40



ER筒夹刀座, DIN 6499B, 内部切削液供应, E4型式

- ER 25 48-E4-40x25
107525000
- ER 32 48-E4-40x32
107532000
- ER 40 48-E4-40x40
107540000



防污塞, 钢材, Z2型式
48-Z2-40-S

动力刀座 - QuickFlex®



直结式钻/铣动力刀座

- ER-32 QF 420132077-40R 1:1 EC
442145W, T32595
0067732000
- ER-32 QF 420132078-40R 1:1 IC 80 bar
0067732000



直角式钻/铣动力刀座

- ER-32 QF 420532042-40R 1:1 EC
442275W
0067732000
- ER-32 QF 420532043-40R 1:1 IC 80 bar
0067732000



直角后缩式钻/铣动力刀座

- ER-32 QF 420532037-40R 1:1 EC
0067732000
- ER-32 QF 420532038-40R 1:1 IC 80 bar
0067732000

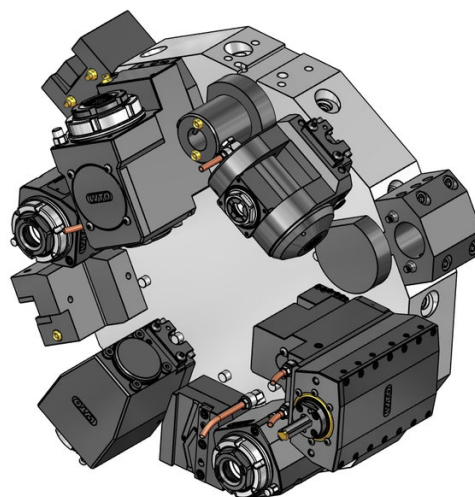
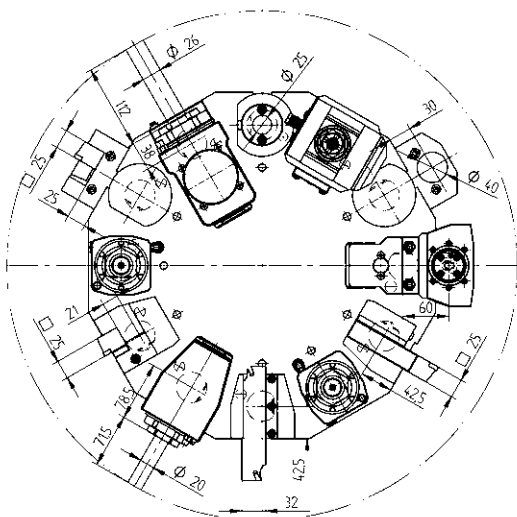

动力刀座 - 扩展产品目录



直结式铣刀座 - 组合铣刀心轴, DIN6358

Ø 22 410222025-40 1:1 EC
 00675000479



直结偏位式钻/铣动力刀座

ER-32 QF 420132054-40R 1:1 EC
 0067732000
 ER-32 QF 420132055-40R 1:1 IC 80 bar
 0067732000
 ER-25 QF 420125024-40R 1:2 EC
 0067725001
 ER-25 QF 420125025-40R 1:2 IC 80 bar
 0067725001
 ER-32 QF 420132056-40R 2:1 EC
 0067732000
 ER-32 QF 420132057-40R 2:1 IC 80 bar
 0067732000



直结偏位式钻/铣动力刀座 - VDI两面齿轮

ER 16 410410001-40 1:3 EC
 00675000937
 ER 16 410410002-40 1:3 IC 80 bar
 00675000937

动力刀座 - 扩展产品目录



直角式钻/铣动力刀座

ER-25 QF 420525058-40 1:2 EC
 0067725001
 ER-25 QF 420525059-40 1:2 IC 80 bar
 0067725001



直角后缩式钻/铣动力刀座

ER-40 QF 420540027-40R 2:1 EC
 0067740000
 ER-40 QF 420540028-40R 2:1 IC 80 bar
 0067740000



可调角度钻/铣动力刀座

ER 20 411013019-40 1:1 EC
 00675000928
 ER 20 411013026-40 1:1 IC 80 bar
 00675000928
 ER 25 411016006-40 1:1 EC
 00675000934
 ER 25 411016024-40 1:1 IC 80 bar
 00675000934
 ER 16 411010012-40 1:2 EC
 00675000936
 ER 16 411010013-40 1:2 IC 80 bar
 00675000936

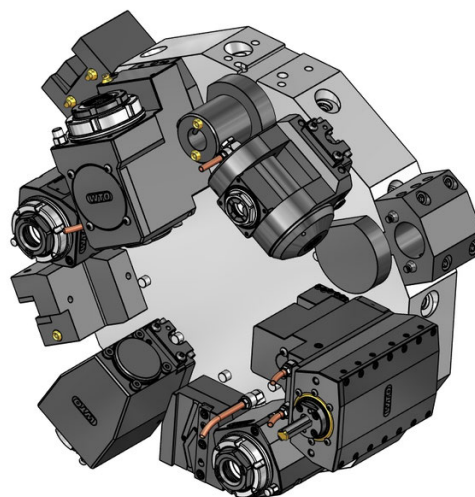
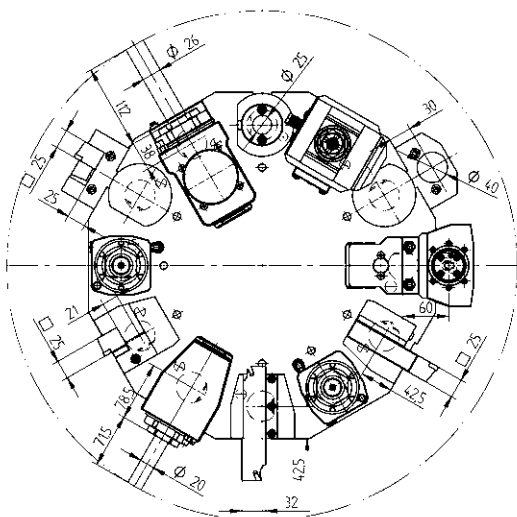

动力刀座 - 扩展产品目录





横向圆盘式铣刀刀座

14-2 型式 411500009-40 2,727:1EC

00675000460

 160016142 Ø 16

 160022142 Ø 22

 160027142 Ø 27

 160015142 Ø 5/8"

 160019142 Ø 3/4"

 160023142 Ø 7/8"

 160025142 Ø 1"



插槽刀座(内外径通用)

32 型式 414132002-40 1:1 EC

52 型式 414152000-40 1:1 EC

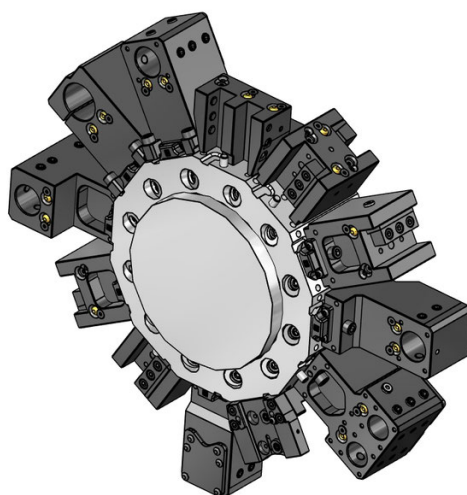
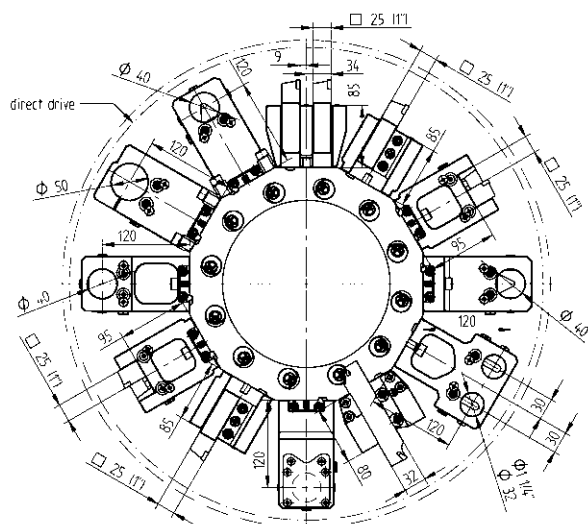



固定刀座 - 标准产品目录

- 

25 车端面 and 车削刀座 - VDI两面齿轮
48-85982
- 

25 车端面 and 车削刀座, 两侧的
48-59098
442340
- 

25 车端面 and 镗削刀座
48-87589
- 

25 车端面 and 镗削刀座, Trifix®
48-96528
- 

Ø 40 组合刀座, 通用的, LF=120
48-64021
241140020 ER32
- 

Ø 40 组合刀座, 通用的, Trifix®, LF=120
48-96530
T12138
241140020 ER32
241140026 ER40

固定刀座 - 标准产品目录

- 

Ø 40 组合刀座, 后缩式 - VDI两面齿轮, LF=120
48-110591
241140020 ER32
- 

Ø 40 组合刀座, 后缩式, 左手刀, Trifix®, LF=120
48-110694
241140026 ER40
241140020 ER32
- 

Ø 40 组合刀座, 后缩式, 右手刀, Trifix®, LF=120
48-97044
241140020 ER32
241140026 ER40
- 

Ø 40 组合刀座, 两侧的, LF=120
48-97388
- 

Ø 40 组合刀座, 两侧的, Trifix®, LF=120
48-97036
T12139

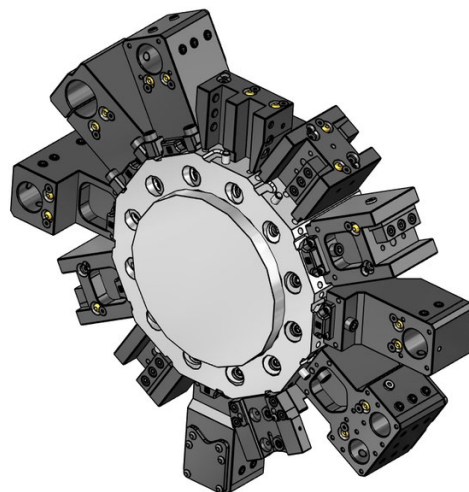
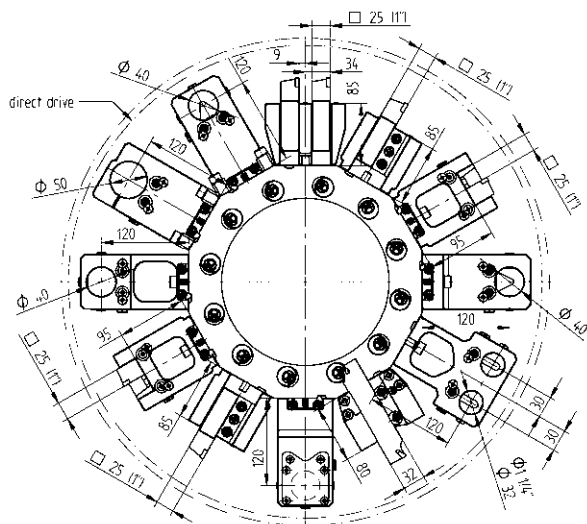

固定刀座 - 标准产品目录

- 

筒夹刀座, 两侧的, LF=120
ER 32 48-66629 IC 80 bar
107532000
- 

ER 40 48-97389 IC 80 bar
107540000
- 

筒夹刀座, 两侧的, Trifix®, LF=120
ER 32 48-97051 IC 80 bar
107532000
- 

ER 40 48-97052 IC 80 bar
107540000
- 

防污塞, 钢材, Z2型式
钢材 48-Z2-40-S

固定刀座 - 扩展产品目录

- 

端面车刀座, 高压内冷 - VDI两面齿
25 48-105986-HP IC 80 bar
- 

车端面 and 车削刀座, 两侧的, HP-IC
25 48-59098-HP
- 

车端面 and 车削刀座, 2刀位, Y-轴 - VDI两面齿轮
25(1") 48-86080
- 

车端面 and 车削刀座, 两侧的, 2刀位, Y-轴
25(1") 48-89779
- 

切断刀用刀座, 可调节的 - VDI两面齿轮
SH 32 48-98963
R9Z455, T00460, T00461
- 

切断刀用刀座, 可调节的, 内部切削液供应, HP-IC - VDI两面齿轮
SH 32 48-102643R IC 80 bar
SH 32 48-102643L IC 80 bar

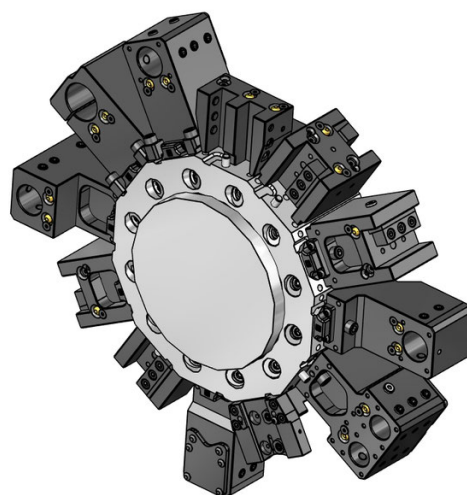
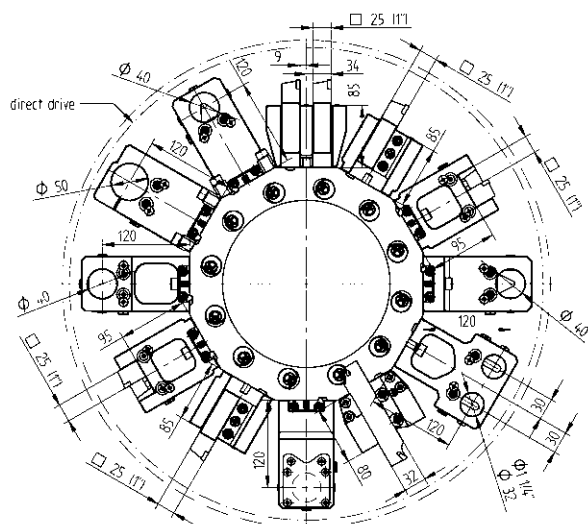

固定刀座 - 扩展产品目录



切断刀用刀座, 可调节的, 长型, 内部切削液供应, HP-IC - VDI两面齿轮

- SH 32 48-99091R IC 80 bar
- 343-810100R8
- SH 32 48-99091L IC 80 bar
- 343-810100L8



组合刀座, 通用的, Trifix®, LF=120 - BMT

- Ø 40 48-97097
- 241140020 ER32
- 241140026 ER40



组合刀座, 后缩式, 左面, Trifix®, LF=120 - BMT

- Ø 40 48-111059
- 241140020 ER32
- 241140026 ER40



组合刀座, 后缩式, 右面, Trifix®, LF=120 - BMT

- Ø 40 48-97164
- 241140020 ER32
- 241140026 ER40



组合刀座, 两侧的, Trifix®, LF=120 - BMT

- Ø 40 48-97105

固定刀座 - 扩展产品目录



镗刀刀座, 带槽, Trifix®, LF=120 - BMT

- Ø 50 48-97257



组合刀座, 通用的, 2刀位, Y-轴, LF=120

- Ø 32 48-86296
- 241132016 ER25
- 241132020 ER32



组合刀座, 通用的, 2刀位, Y-轴, LF=120, Trifix®

- Ø 32 48-96531
- 241132016 ER25
- 241132020 ER32

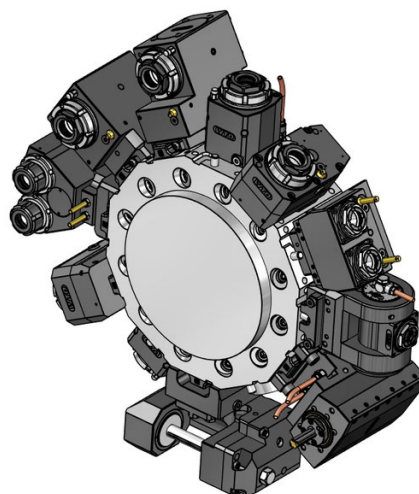
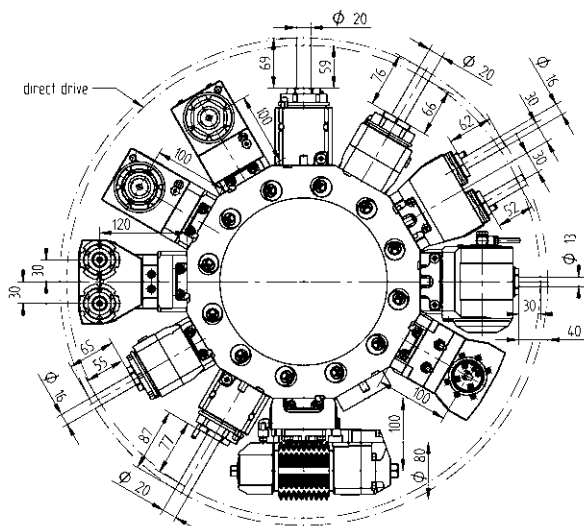

动力刀座 - QuickFlex®



直结式钻/铣动力刀座 (6000 RPM)

- ER-32 QF 420132077-40L 1:1 EC
0067732000
- ER-32 QF 420132078-40L 1:1 IC 80 bar
0067732000



直结式钻/铣动力刀座 (10000 RPM)

- ER-32 QF 420132069-40L 1:1 EC
442141W
0067732000
- ER-32 QF 420132070-40L 1:1 IC 80 bar
0067732000



直角式钻/铣动力刀座, Trifix®, LF=100, (6000 RPM)

- ER-32 QF 420532015-40L 1:1 EC
0067732000
- ER-32 QF 420532016-40L 1:1 IC 80 bar
0067732000



直角式钻/铣动力刀座, Trifix®, LF=100, (10000 RPM)

- ER-32 QF 420532024-40L 1:1 EC
0067732000
- ER-32 QF 420532025-40L 1:1 IC 80 bar
0067732000

动力刀座 - QuickFlex®



直角式钻/铣动力刀座, Trifix®, LF=100, (6000 RPM)

- ER-32 QF 420532015-40R 1:1 EC
0067732000
- ER-32 QF 420532016-40R 1:1 IC 80 bar
0067732000



直角式钻/铣动力刀座, Trifix®, LF=100, (10000 RPM)

- ER-32 QF 420532024-40R 1:1 EC
0067732000
- ER-32 QF 420532025-40R 1:1 IC 80 bar
0067732000



直角后缩式钻/铣动力刀座, Trifix®, LF=100, (6000 RPM)

- ER-32 QF 420532032-40L 1:1 EC
0067732000
- ER-32 QF 420532033-40L 1:1 IC 80 bar
0067732000



直角后缩式钻/铣动力刀座, Trifix®, LF=100, (10000 RPM)

- ER-32 QF 420532081-40L 1:1 EC
0067732000
- ER-32 QF 420532082-40L 1:1 IC 80 bar
0067732000

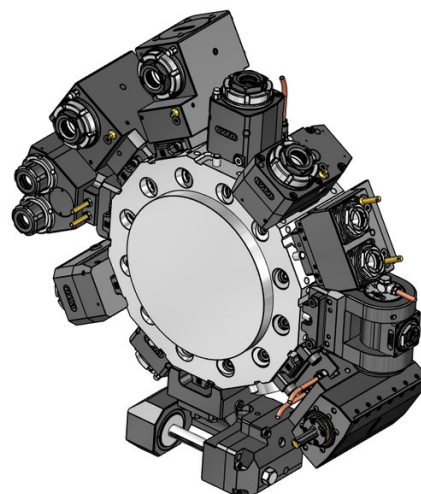
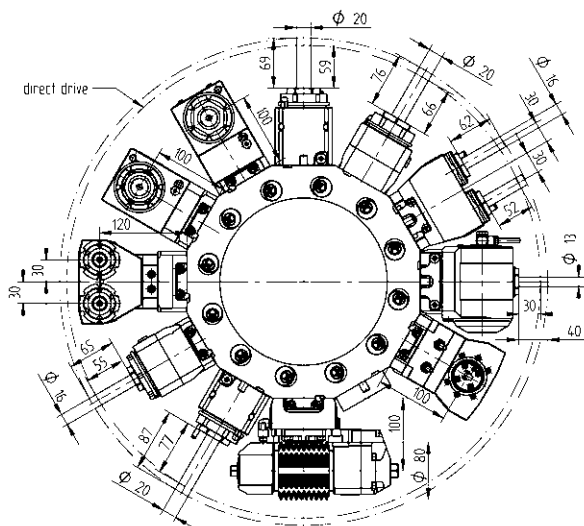

动力刀座 - QuickFlex®



直角后缩式钻/铣动力刀座, Trifix®, LF=100, (6000 RPM)

ER-32 QF 420532032-40R 1:1 EC
 0067732000

ER-32 QF 420532033-40R 1:1 IC 80 bar
 0067732000



直角后缩式钻/铣动力刀座, Trifix®, LF=100, (10000 RPM)

ER-32 QF 420532081-40R 1:1 EC
 0067732000

ER-32 QF 420532082-40R 1:1 IC 80 bar
 0067732000



直角式钻/铣动力刀座, 两侧的, Trifix®, LF=100, (6000 RPM)

ER-32 QF 420532017-40 1:1 EC
 0067732000



直角式钻/铣动力刀座, 两侧的, Trifix®, LF=100, (10000 RPM)

ER-32 QF 420532133-40 1:1 EC
 0067732000

动力刀座 - 扩展产品目录



直结式钻/铣动力刀座 - BMT

ER-40 QF 420140010-40 1:1 EC
 0067740000

ER-40 QF 420140011-40 1:1 IC 80 bar
 0067740000



直结式铣刀座 - 组合铣刀心轴, DIN6358

Ø 22 410222025-40 1:1 EC
 00675000479



直结式铣刀座 - BMT - 组合铣刀心轴, DIN6358

Ø 22 410222022-40 1:1 EC
 00675000479

Ø 27 410227010-40 1:1 EC
 00675000480

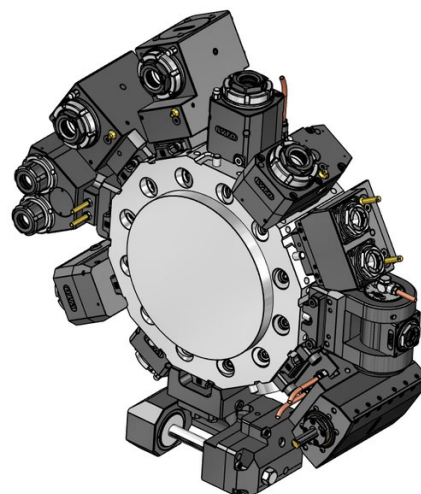
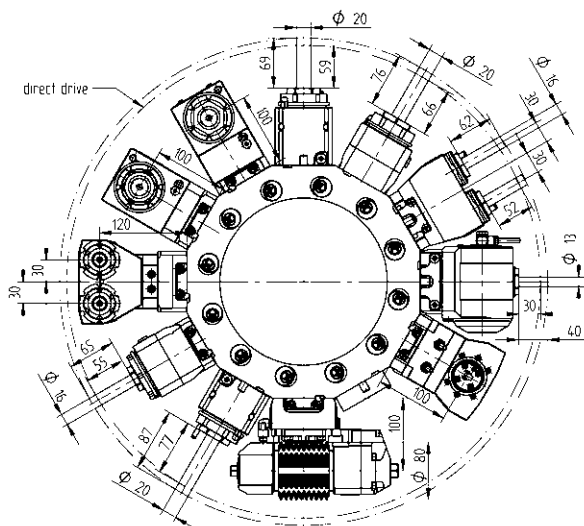

动力刀座 - 扩展产品目录



直结偏位式钻/铣动力刀座

| | | | |
|----------|---------------|-----|-----------|
| ER-32 QF | 420132054-40L | 1:1 | EC |
| | 0067732000 | | |
| ER-32 QF | 420132055-40L | 1:1 | IC 80 bar |
| | 0067732000 | | |
| ER-25 QF | 420125024-40L | 1:2 | EC |
| | 0067725001 | | |
| ER-25 QF | 420125025-40L | 1:2 | IC 80 bar |
| | 0067725001 | | |
| ER-32 QF | 420132056-40L | 2:1 | EC |
| | 0067732000 | | |
| ER-32 QF | 420132057-40L | 2:1 | IC 80 bar |
| | 0067732000 | | |



直结偏位式钻/铣动力刀座, Trifix®

| | | | |
|----------|---------------|-----|-----------|
| ER-25 QF | 420125039-40L | 1:2 | EC |
| | 0067725001 | | |
| ER-25 QF | 420125038-40L | 1:2 | IC 80 bar |
| | 0067725001 | | |



直结偏位式钻/铣动力刀座, Trifix®

| | | | |
|----------|---------------|-----|-----------|
| ER-25 QF | 420125039-40R | 1:2 | EC |
| | 0067725001 | | |
| ER-25 QF | 420125038-40R | 1:2 | IC 80 bar |
| | 0067725001 | | |

动力刀座 - 扩展产品目录



直角式钻/铣动力刀座, Trifix®, LF=100 - BMT

| | | | |
|----------|---------------|-----|-----------|
| ER-32 QF | 420532028-40L | 1:1 | EC |
| | 0067732000 | | |
| ER-32 QF | 420532029-40L | 1:1 | IC 80 bar |
| | 0067732000 | | |
| ER-40 QF | 420540010-40L | 2:1 | EC |
| | 0067740000 | | |
| ER-40 QF | 420540011-40L | 2:1 | IC 80 bar |
| | 0067740000 | | |



直角式钻/铣动力刀座, Trifix®, LF=100 - BMT

| | | | |
|----------|---------------|-----|-----------|
| ER-32 QF | 420532028-40R | 1:1 | EC |
| | 0067732000 | | |
| ER-32 QF | 420532029-40R | 1:1 | IC 80 bar |
| | 0067732000 | | |
| ER-40 QF | 420540010-40R | 2:1 | EC |
| | 0067740000 | | |
| ER-40 QF | 420540011-40R | 2:1 | IC 80 bar |
| | 0067740000 | | |



直角式钻/铣动力刀座, Trifix®, LF=100

| | | | |
|----------|---------------|-----|-----------|
| ER-25 QF | 420525017-40L | 1:2 | EC |
| | 0067725000 | | |
| ER-25 QF | 420525018-40L | 1:2 | IC 80 bar |
| | 0067725000 | | |

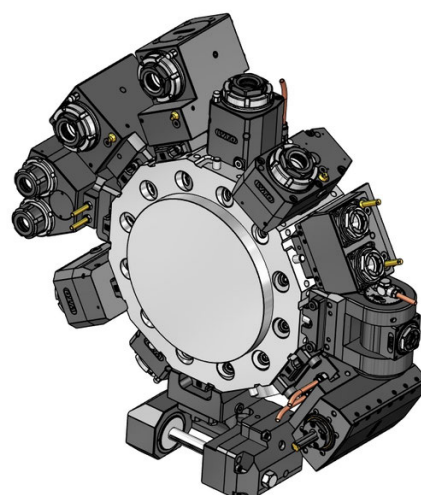
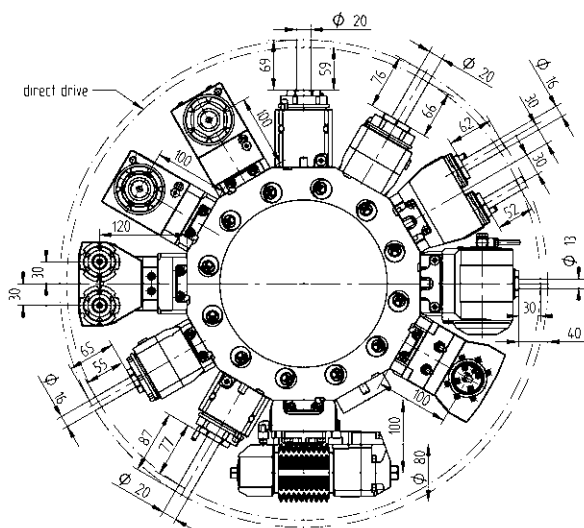

动力刀座 - 扩展产品目录

动力刀座 - 扩展产品目录



直角式钻/铣动力刀座, Trifix®, LF=100

ER-25 QF 420525017-40R 1:2 EC
0067725000

ER-25 QF 420525018-40R 1:2 IC 80 bar
0067725000



直角式钻/铣动力刀座, 两侧的, Trifix®, LF=100 - BMT

ER-40 QF 420540017-40 1:1 EC
0067740000



直角式铣动力刀座 - VDI两面齿轮, LF=100

Ø 22 410622028-40 2:1 EC
00675000160

Ø 27 410627015-40 2:1 EC
00675000211

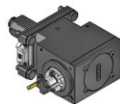

直角式铣动力刀座, Trifix®, LF=100 - BMT

Ø 22 410622031-40L 2:1 EC
00675000160

Ø 27 410627016-40L 2:1 EC
00675000211



直角式铣动力刀座, Trifix®, LF=100 - BMT

Ø 22 410622031-40R 2:1 EC
00675000160

Ø 27 410627016-40R 2:1 EC
00675000211



可调角度钻/铣动力刀座

ER 20 411013018-40 1:1 EC
00675000928

ER 20 411013029-40 1:1 IC 80 bar
00675000928

ER 16 411010030-40 1:2 EC
00675000936

ER 16 411010031-40 1:2 IC 80 bar
00675000936



圆盘铣刀刀座

14-2 型式 410900013-40 2,615:1EC
00675000460

160016142 Ø 16

160022142 Ø 22

160027142 Ø 27

160015142 Ø 5/8"

160019142 Ø 3/4"

160023142 Ø 7/8"

160025142 Ø 1"

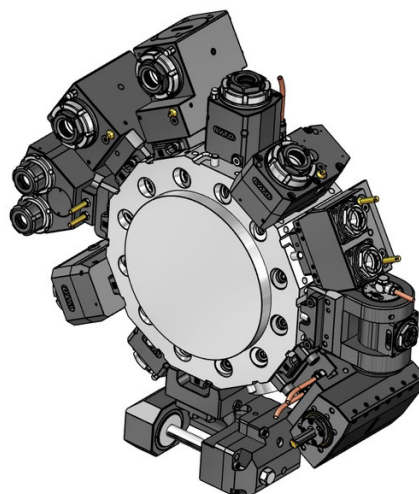
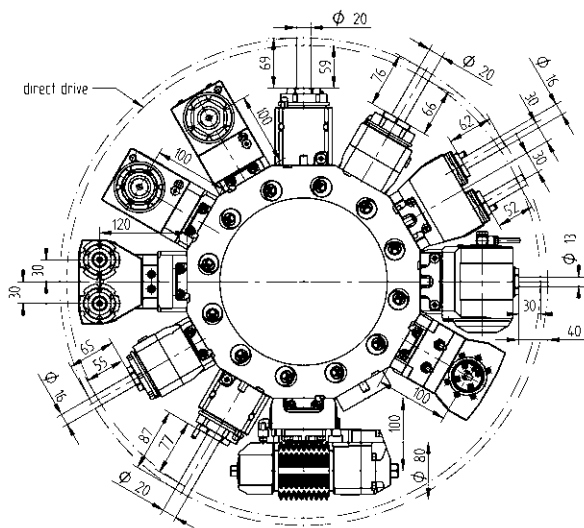

动力刀座 - 扩展产品目录

动力刀座 - 扩展产品目录



滚齿刀座, Trifix®

| | | | |
|---------|--------------------|-----|----|
| 16-1 型式 | 411500041-40L | 1:1 | EC |
| 16-1 型式 | 411500037-40L | 2:1 | EC |
| | 00675000926 | | |
| | 160016161 Ø 16 | | |
| | 160022161 Ø 22 | | |
| | 160027161 Ø 27 | | |
| | 160015161 Ø 5/8" | | |
| | 160019161 Ø 3/4" | | |
| | 160025161 Ø 1" | | |
| | 160031161 Ø 1 1/4" | | |
| | 110587 | | |



滚齿刀座, Trifix®

| | | | |
|---------|--------------------|-----|----|
| 16-1 型式 | 411500041-40R | 1:1 | EC |
| 16-1 型式 | 411500037-40R | 2:1 | EC |
| | 110587 | | |
| | 160031161 Ø 1 1/4" | | |
| | 160022161 Ø 22 | | |
| | 160016161 Ø 16 | | |
| | 00675000926 | | |
| | 160027161 Ø 27 | | |
| | 160025161 Ø 1" | | |
| | 160019161 Ø 3/4" | | |
| | 160015161 Ø 5/8" | | |

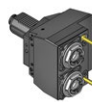

直结式钻/铣刀座, 2刀位, Y-轴

| | | | |
|-------|--------------|-------|-----------|
| ER 25 | 413002034-40 | 1:1,5 | EC |
| | 00675000930 | | |
| ER 25 | 413002035-40 | 1:1,5 | IC 80 bar |
| | 00675000930 | | |

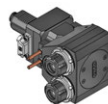

二轴直角式钻/铣动力刀座, Y-轴, LF=120, Trifix®

| | | | |
|-------|---------------|-----|-----------|
| ER 25 | 413502024-40L | 1:1 | EC |
| | 00675000915 | | |
| ER 25 | 413502025-40L | 1:1 | IC 80 bar |
| | 00675000915 | | |

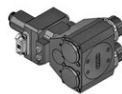

二轴直角式钻/铣动力刀座, Y-轴, LF=120, Trifix®

| | | | |
|-------|---------------|-----|-----------|
| ER 25 | 413502024-40R | 1:1 | EC |
| | 00675000915 | | |
| ER 25 | 413502025-40R | 1:1 | IC 80 bar |
| | 00675000915 | | |

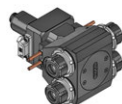

二轴直角式钻/铣动力刀座, 两侧的, Y-轴, LF=120, Trifix®

| | | | |
|-------|--------------|-----|----|
| ER 25 | 413502026-40 | 1:1 | EC |
| | 00675000915 | | |



插槽刀座(内外径通用), 两面齿轮, LF=120

| | | | |
|-------|--------------|-----|----|
| 32 型式 | 414532013-40 | 1:1 | EC |
|-------|--------------|-----|----|

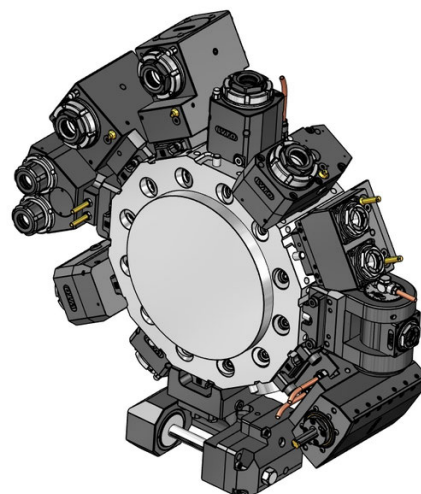
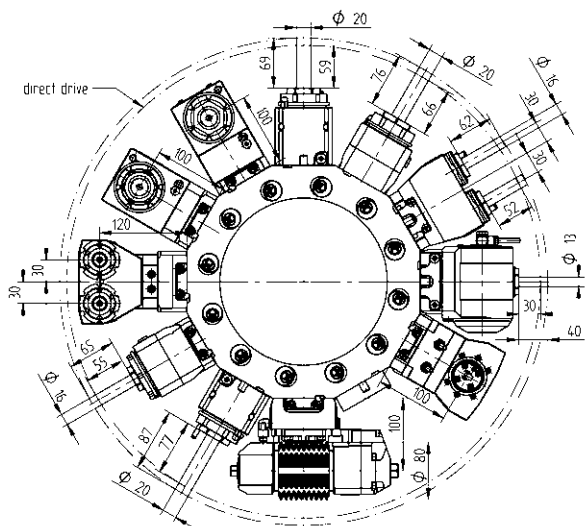

动力刀座 - 扩展产品目录

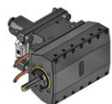

插槽刀座 (内外径通用), Trifix®, LF=100 - BMT

| | | | |
|-------|---------------|-----|----|
| 32 型式 | 414532007-40L | 1:1 | EC |
| 52 型式 | 414552001-40L | 1:1 | EC |



插槽刀座 (内外径通用), Trifix®, LF=100 - BMT

| | | | |
|-------|---------------|-----|----|
| 32 型式 | 414532007-40R | 1:1 | EC |
| 52 型式 | 414552001-40R | 1:1 | EC |

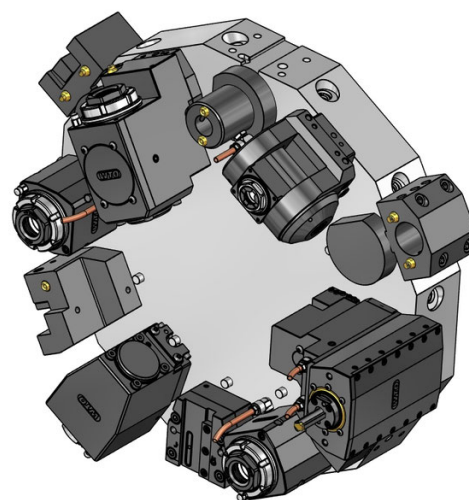
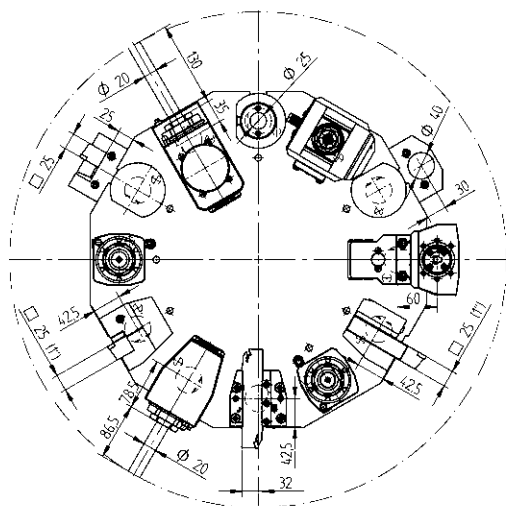

固定刀座 - 标准产品目录

固定刀座 - 标准产品目录



车端面和镗削刀座

25 48-PU2-25-25



组合刀座

| | | |
|------|--------------|-----------|
| Ø 20 | 48-PU1-25-20 | IC 80 bar |
| Ø 25 | 48-PU1-25-25 | IC 80 bar |
| Ø 32 | 48-PU1-25-32 | IC 80 bar |
| Ø 40 | 48-PU1-25-40 | IC 80 bar |
| Ø 50 | 48-PU1-25-50 | IC 80 bar |



VDI适配器, 右手刀

VDI 40 48-99856



径向右手方形刀座, 短型, B1型式

25(20) 48-B1-40x25

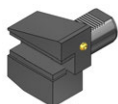

径向右手方形刀座, 反刀, 短型, B3型式

25(20) 48-B3-40x25



径向右手方形刀座, 长型, B5型式

25(20) 48-B5-40x25



径向右手方形刀座, 反刀, 长型, B7型式

25(20) 48-B7-40x25



径向方形刀座, HP-IC - VDI两面齿轮

| | | |
|----|---------------|-----------|
| 25 | 48-105989R-HP | IC 80 bar |
| 25 | 48-102790L-HP | IC 80 bar |

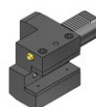

方形刀柄轴向刀座, 右手刀, C1型式

25(20) 48-C1-40x25

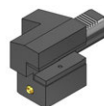

方形刀柄轴向刀座, 右手反刀, C3型式

25(20) 48-C3-40x25



切断刀用刀座, 高度可调整, 右手刀

| | |
|-------|-------------|
| SH 26 | 48-AR-40x26 |
| SH 32 | 48-AR-40x32 |



切断刀用刀座, 高度可调整, 右手反刀

SH 26 48-ARU-40x26



切断刀用刀座, 高度可调整, 内部切削液供应

| | | |
|-------|------------|-----------|
| SH 32 | 48-102690R | IC 80 bar |
| SH 32 | 48-102690L | IC 80 bar |

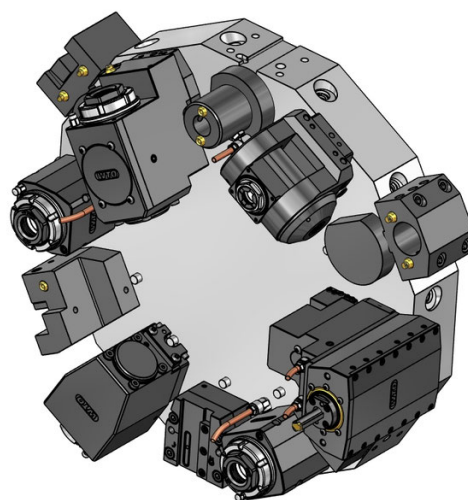
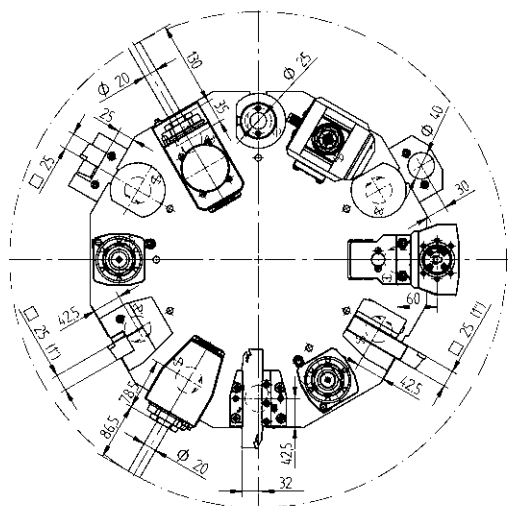

固定刀座 - 标准产品目录



可转位式钻刀座, 内部切削液供应, E1型式

- Ø 16 48-E1-40x16
- Ø 20 48-E1-40x20
- Ø 25 48-E1-40x25
- Ø 32 48-E1-40x32
- Ø 40 48-E1-40x40



镗刀刀座, 内部切削液供应, E2型式

- Ø 8 48-E2-40x8
- Ø 10 48-E2-40x10
- Ø 12 48-E2-40x12
- Ø 16 48-E2-40x16
- Ø 20 48-E2-40x20
- Ø 25 48-E2-40x25
- Ø 30 48-E2-40x30
- Ø 32 48-E2-40x32
- Ø 40 48-E2-40x40



ER筒夹刀座, DIN 6499B, 内部切削液供应, E4型式

- ER 25 48-E4-40x25
107525000
- ER 32 48-E4-40x32
107532000
- ER 40 48-E4-40x40
107540000



防污塞, 钢材, Z2型式
48-Z2-40-S

动力刀座 - QuickFlex®



直结式钻/铣动力刀座

- ER-32 QF 420132077-40R 1:1 EC
442145W, T32595
0067732000
- ER-32 QF 420132078-40R 1:1 IC 80 bar
0067732000



直角式钻/铣动力刀座

- ER-32 QF 420532042-40R 1:1 EC
442275W
0067732000
- ER-32 QF 420532043-40R 1:1 IC 80 bar
0067732000



直角后缩式钻/铣动力刀座

- ER-32 QF 420532037-40R 1:1 EC
0067732000
- ER-32 QF 420532038-40R 1:1 IC 80 bar
0067732000

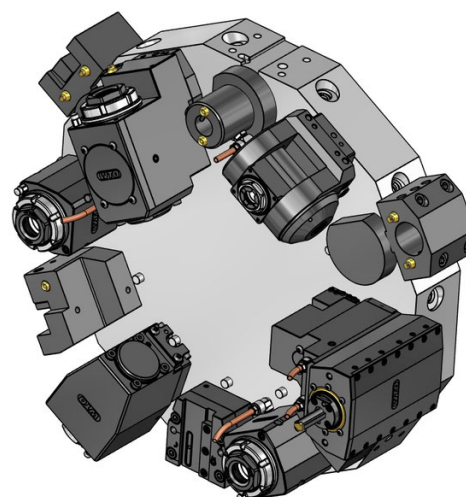
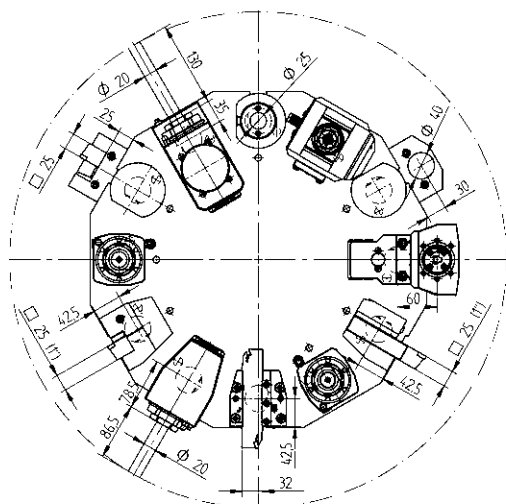

动力刀座 - 扩展产品目录



直结式铣刀座 - 组合铣刀心轴, DIN6358

Ø 22 410222025-40 1:1 EC
 00675000479



直结偏位式钻/铣动力刀座

ER-32 QF 420132054-40R 1:1 EC
 0067732000
 ER-32 QF 420132055-40R 1:1 IC 80 bar
 0067732000
 ER-25 QF 420125024-40R 1:2 EC
 0067725001
 ER-25 QF 420125025-40R 1:2 IC 80 bar
 0067725001
 ER-32 QF 420132056-40R 2:1 EC
 0067732000
 ER-32 QF 420132057-40R 2:1 IC 80 bar
 0067732000



直结偏位式钻/铣动力刀座 - VDI两面齿轮

ER 16 410410001-40 1:3 EC
 00675000937
 ER 16 410410002-40 1:3 IC 80 bar
 00675000937

动力刀座 - 扩展产品目录



直角式钻/铣动力刀座

ER-25 QF 420525058-40 1:2 EC
 0067725001
 ER-25 QF 420525059-40 1:2 IC 80 bar
 0067725001



直角后缩式钻/铣动力刀座

ER-40 QF 420540027-40R 2:1 EC
 0067740000
 ER-40 QF 420540028-40R 2:1 IC 80 bar
 0067740000



可调角度钻/铣动力刀座

ER 20 411013019-40 1:1 EC
 00675000928
 ER 20 411013026-40 1:1 IC 80 bar
 00675000928
 ER 25 411016006-40 1:1 EC
 00675000934
 ER 25 411016024-40 1:1 IC 80 bar
 00675000934
 ER 16 411010012-40 1:2 EC
 00675000936
 ER 16 411010013-40 1:2 IC 80 bar
 00675000936

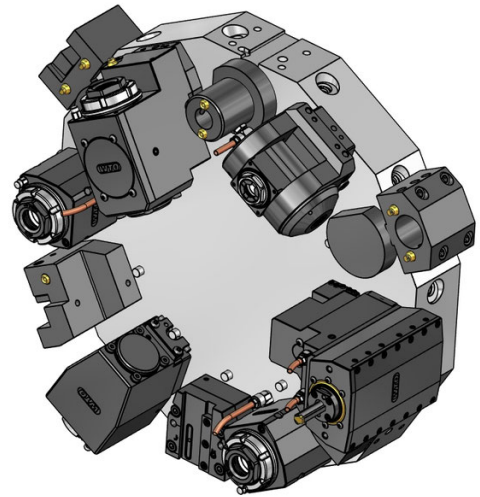
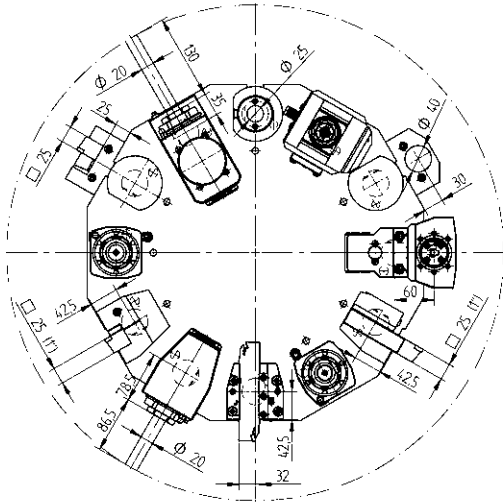

动力刀座 - 扩展产品目录



横向圆盘式铣刀刀座

14-2 型式 411500009-40 2,727:1EC

00675000460

 160016142 Ø 16

 160022142 Ø 22

 160027142 Ø 27

 160015142 Ø 5/8"

 160019142 Ø 3/4"

 160023142 Ø 7/8"

 160025142 Ø 1"



插槽刀座(内外径通用)

32 型式 414132002-40 1:1 EC

52 型式 414152000-40 1:1 EC

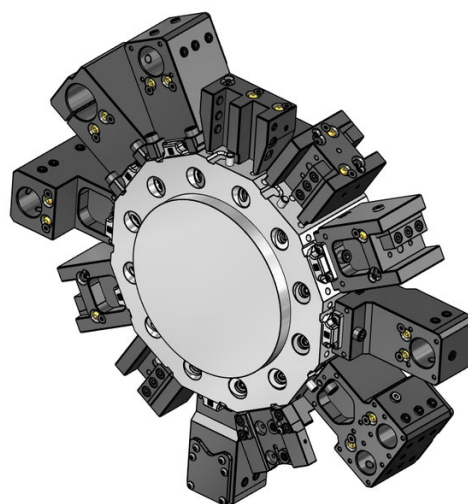
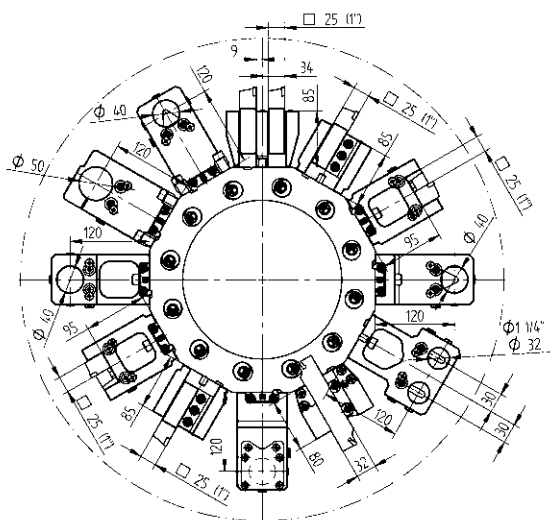

固定刀座 - 标准产品目录

- 

25 车端面 and 车削刀座 - VDI两面齿轮
48-85982
- 

25 车端面 and 车削刀座, 两侧的
48-59098
442340
- 

25 车端面 and 镗削刀座
48-87589
- 

25 车端面 and 镗削刀座, Trifix®
48-96528
- 

Ø 40 组合刀座, 通用的, LF=120
48-64021
241140020 ER32
- 

Ø 40 组合刀座, 通用的, Trifix®, LF=120
48-96530
T12138
241140020 ER32
241140026 ER40

固定刀座 - 标准产品目录

- 

Ø 40 组合刀座, 后缩式 - VDI两面齿轮, LF=120
48-110591
241140020 ER32
- 

Ø 40 组合刀座, 后缩式, 左手刀, Trifix®, LF=120
48-110694
241140026 ER40
241140020 ER32
- 

Ø 40 组合刀座, 后缩式, 右手刀, Trifix®, LF=120
48-97044
241140020 ER32
241140026 ER40
- 

Ø 40 组合刀座, 两侧的, LF=120
48-97388
- 

Ø 40 组合刀座, 两侧的, Trifix®, LF=120
48-97036
T12139

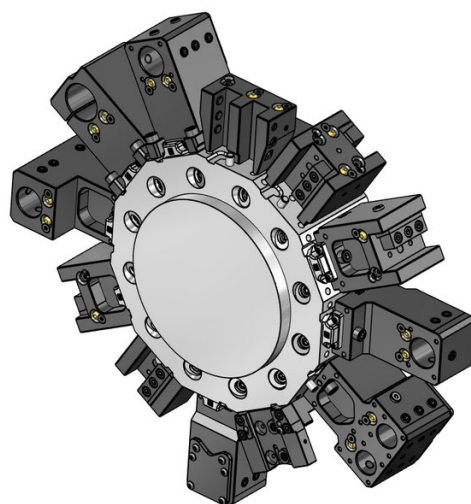
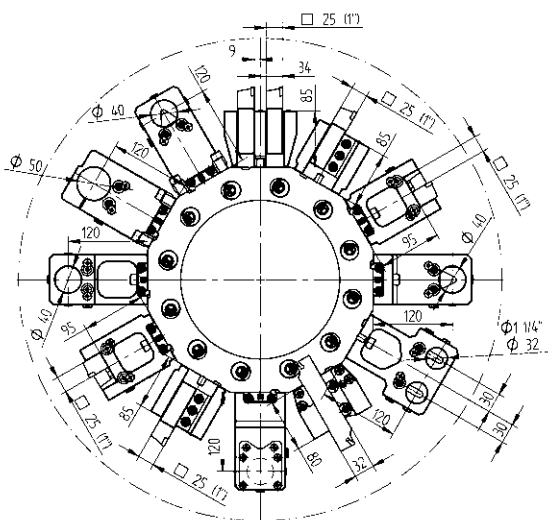

固定刀座 - 标准产品目录

- 

筒夹刀座, 两侧的, LF=120
ER 32 48-66629 IC 80 bar
107532000
- 

ER 40 48-97389 IC 80 bar
107540000
- 

筒夹刀座, 两侧的, Trifix®, LF=120
ER 32 48-97051 IC 80 bar
107532000
- 

ER 40 48-97052 IC 80 bar
107540000
- 

防污塞, 钢材, Z2型式
钢材 48-Z2-40-S

固定刀座 - 扩展产品目录

- 

端面车刀座, 高压内冷 - VDI两面齿
25 48-105986-HP IC 80 bar
- 

车端面 and 车削刀座, 两侧的, HP-IC
25 48-59098-HP
- 

车端面 and 车削刀座, 2刀位, Y-轴 - VDI两面齿
25(1") 48-86080
- 

车端面 and 车削刀座, 两侧的, 2刀位, Y-轴
25(1") 48-89779
- 

切断刀用刀座, 可调节的 - VDI两面齿
SH 32 48-98963
R9Z455, T00460, T00461
- 

切断刀用刀座, 可调节的, 内部切削液供应, HP-IC - VDI两面齿
SH 32 48-102643R IC 80 bar
SH 32 48-102643L IC 80 bar

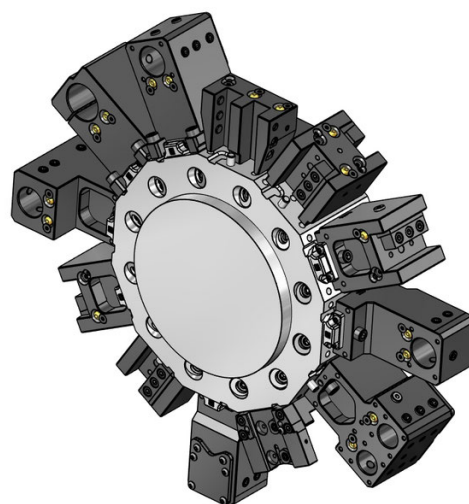
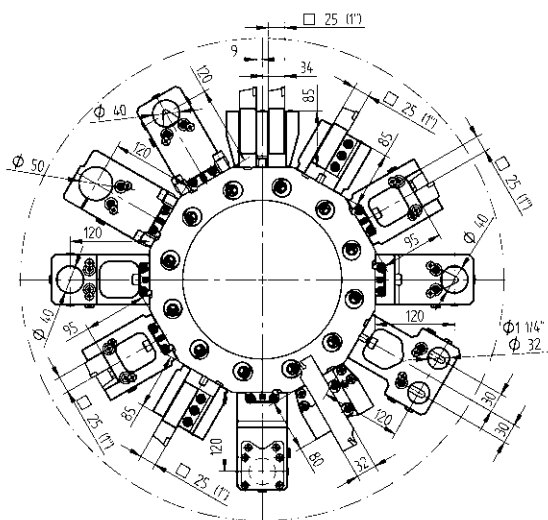

固定刀座 - 扩展产品目录





切断刀用刀座, 可调节的, 长型, 内部切削液供应, HP-IC - VDI两面齿轮

- SH 32 48-99091R IC 80 bar
- 343-810100R8
- SH 32 48-99091L IC 80 bar
- 343-810100L8





组合刀座, 通用的, Trifix®, LF=120 - BMT

- Ø 40 48-97097
-  241140020 ER32
-  241140026 ER40





组合刀座, 后缩式, 左面, Trifix®, LF=120 - BMT

- Ø 40 48-111059
-  241140020 ER32
-  241140026 ER40



组合刀座, 后缩式, 右面, Trifix®, LF=120 - BMT

- Ø 40 48-97164
-  241140020 ER32
-  241140026 ER40



组合刀座, 两侧的, Trifix®, LF=120 - BMT

- Ø 40 48-97105

固定刀座 - 扩展产品目录





镗刀刀座, 带槽, Trifix®, LF=120 - BMT

- Ø 50 48-97257





组合刀座, 通用的, 2刀位, Y-轴, LF=120

- Ø 32 48-86296
-  241132016 ER25
-  241132020 ER32



组合刀座, 通用的, 2刀位, Y-轴, LF=120, Trifix®

- Ø 32 48-96531
-  241132016 ER25
-  241132020 ER32

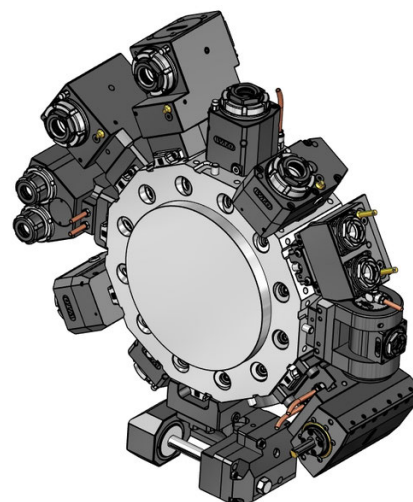
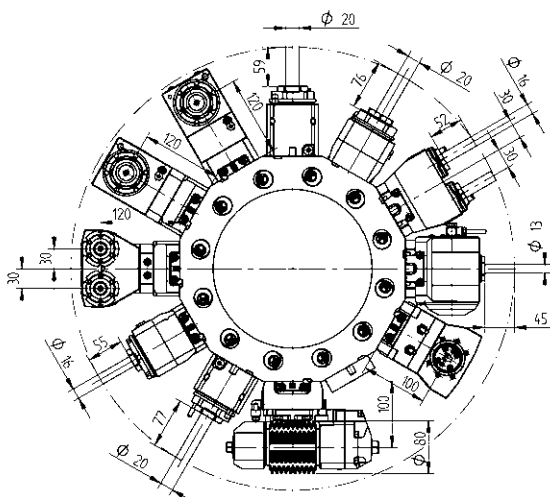

动力刀座 - QuickFlex®



直结式钻/铣动力刀座 (6000 RPM)

- ER-32 QF 420132077-40L 1:1 EC
0067732000
- ER-32 QF 420132078-40L 1:1 IC 80 bar
0067732000



直结式钻/铣动力刀座 (10000 RPM)

- ER-32 QF 420132069-40L 1:1 EC
442141W
0067732000
- ER-32 QF 420132070-40L 1:1 IC 80 bar
0067732000



直角式钻/铣动力刀座, Trifix®, LF=120, (6000 RPM)

- ER-32 QF 420532018-40L 1:1 EC
T32591
0067732000
- ER-32 QF 420532019-40L 1:1 IC 80 bar
0067732000



直角式钻/铣动力刀座, Trifix®, LF=120, (10000 RPM)

- ER-32 QF 420532026-40L 1:1 EC
T32593
0067732000
- ER-32 QF 420532027-40L 1:1 IC 80 bar
0067732000

动力刀座 - QuickFlex®



直角式钻/铣动力刀座, Trifix®, LF=120, (6000 RPM)

- ER-32 QF 420532018-40R 1:1 EC
T32592
0067732000
- ER-32 QF 420532019-40R 1:1 IC 80 bar
0067732000



直角式钻/铣动力刀座, Trifix®, LF=120, (10000 RPM)

- ER-32 QF 420532026-40R 1:1 EC
T32594
0067732000
- ER-32 QF 420532027-40R 1:1 IC 80 bar
0067732000



直角后缩式钻/铣动力刀座, Trifix®, LF=120, (6000 RPM)

- ER-32 QF 420532034-40L 1:1 EC
0067732000
- ER-32 QF 420532035-40L 1:1 IC 80 bar
0067732000



直角后缩式钻/铣动力刀座, Trifix®, LF=120, (10000 RPM)

- ER-32 QF 420532064-40L 1:1 EC
0067732000
- ER-32 QF 420532065-40L 1:1 IC 80 bar
0067732000

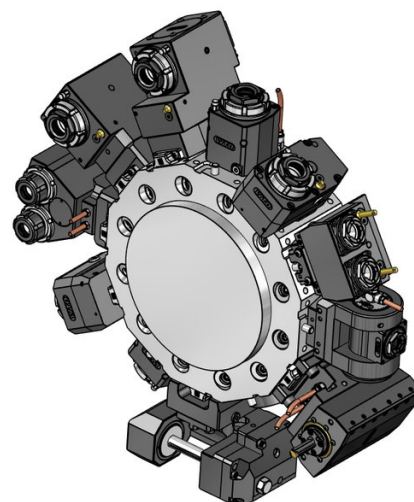
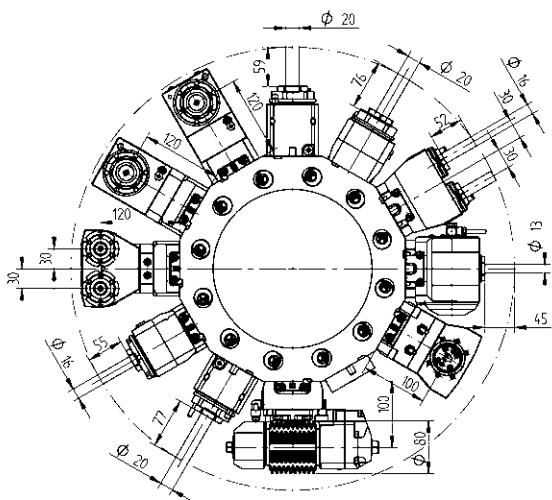

动力刀座 - QuickFlex®



直角后缩式钻/铣动力刀座, Trifix®, LF=120, (6000 RPM)

ER-32 QF 420532034-40R 1:1 EC
 0067732000

ER-32 QF 420532035-40R 1:1 IC 80 bar
 0067732000



直角后缩式钻/铣动力刀座, Trifix®, LF=120, (10000 RPM)

ER-32 QF 420532064-40R 1:1 EC
 0067732000

ER-32 QF 420532065-40R 1:1 IC 80 bar
 0067732000



直角式钻/铣动力刀座, 两侧的, Trifix®, LF=120, (6000 RPM)

ER-32 QF 420532020-40 T32597 1:1 EC
 0067732000



直角式钻/铣动力刀座, 两侧的, Trifix®, LF=120, (10000 RPM)

ER-32 QF 420532127-40 1:1 EC
 0067732000

动力刀座 - 扩展产品目录



直结式钻/铣动力刀座 - BMT

ER-40 QF 420140010-40 1:1 EC
 0067740000

ER-40 QF 420140011-40 1:1 IC 80 bar
 0067740000



直结式铣刀座 - 组合铣刀心轴, DIN6358

Ø 22 410222025-40 1:1 EC
 00675000479



直结式铣刀座 - BMT - 组合铣刀心轴, DIN6358

Ø 22 410222022-40 1:1 EC
 00675000479

Ø 27 410227010-40 1:1 EC
 00675000480

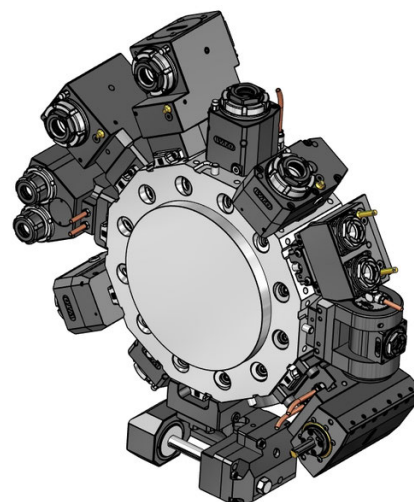
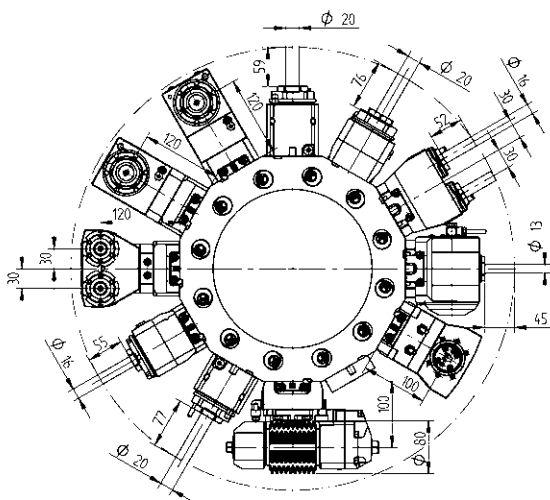

动力刀座 - 扩展产品目录



直结偏位式钻/铣动力刀座

| | | | |
|----------|---------------|-----|-----------|
| ER-32 QF | 420132054-40L | 1:1 | EC |
| | 0067732000 | | |
| ER-32 QF | 420132055-40L | 1:1 | IC 80 bar |
| | 0067732000 | | |
| ER-25 QF | 420125024-40L | 1:2 | EC |
| | 0067725001 | | |
| ER-25 QF | 420125025-40L | 1:2 | IC 80 bar |
| | 0067725001 | | |
| ER-32 QF | 420132056-40L | 2:1 | EC |
| | 0067732000 | | |
| ER-32 QF | 420132057-40L | 2:1 | IC 80 bar |
| | 0067732000 | | |



直结偏位式钻/铣动力刀座, Trifix®

| | | | |
|----------|---------------|-----|-----------|
| ER-25 QF | 420125039-40L | 1:2 | EC |
| | 0067725001 | | |
| ER-25 QF | 420125038-40L | 1:2 | IC 80 bar |
| | 0067725001 | | |



直结偏位式钻/铣动力刀座, Trifix®

| | | | |
|----------|---------------|-----|-----------|
| ER-25 QF | 420125039-40R | 1:2 | EC |
| | 0067725001 | | |
| ER-25 QF | 420125038-40R | 1:2 | IC 80 bar |
| | 0067725001 | | |

动力刀座 - 扩展产品目录



直角式钻/铣动力刀座, Trifix®, LF=100 - BMT

| | | | |
|----------|---------------|-----|-----------|
| ER-32 QF | 420532028-40L | 1:1 | EC |
| | 0067732000 | | |
| ER-32 QF | 420532029-40L | 1:1 | IC 80 bar |
| | 0067732000 | | |
| ER-40 QF | 420540010-40L | 2:1 | EC |
| | 0067740000 | | |
| ER-40 QF | 420540011-40L | 2:1 | IC 80 bar |
| | 0067740000 | | |



直角式钻/铣动力刀座, Trifix®, LF=100 - BMT

| | | | |
|----------|---------------|-----|-----------|
| ER-32 QF | 420532028-40R | 1:1 | EC |
| | 0067732000 | | |
| ER-32 QF | 420532029-40R | 1:1 | IC 80 bar |
| | 0067732000 | | |
| ER-40 QF | 420540010-40R | 2:1 | EC |
| | 0067740000 | | |
| ER-40 QF | 420540011-40R | 2:1 | IC 80 bar |
| | 0067740000 | | |



直角式钻/铣动力刀座, Trifix®, LF=120 - BMT

| | | | |
|----------|---------------|-----|-----------|
| ER-32 QF | 420532030-40L | 1:1 | EC |
| | 0067732000 | | |
| ER-32 QF | 420532031-40L | 1:1 | IC 80 bar |
| | 0067732000 | | |
| ER-40 QF | 420540014-40L | 1:1 | EC |
| | 0067740000 | | |
| ER-40 QF | 420540015-40L | 1:1 | IC 80 bar |
| | 0067740000 | | |

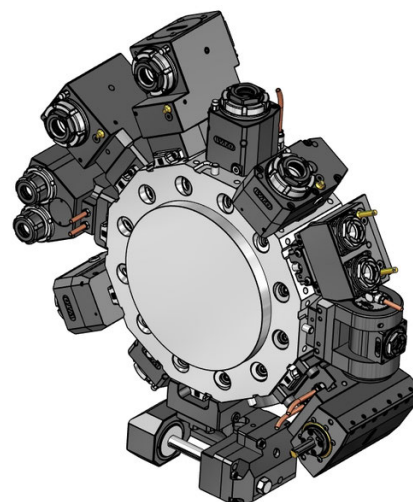
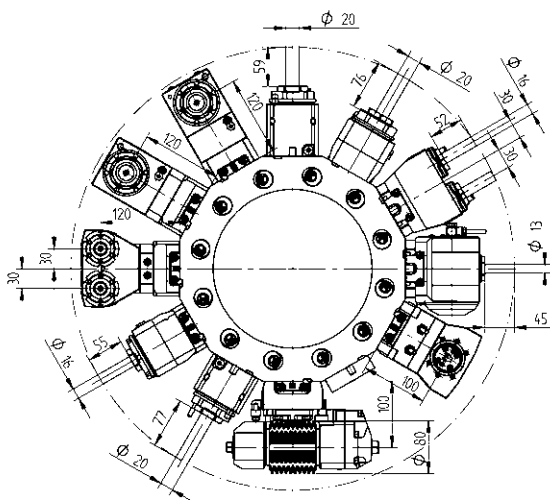

动力刀座 - 扩展产品目录

动力刀座 - 扩展产品目录



可调角度钻/铣动力刀座

| | | | |
|-------|-----------------------------|-----|-----------|
| ER 20 | 411013019-40 00675000928 | 1:1 | EC |
| ER 20 | 411013026-40 00675000928 | 1:1 | IC 80 bar |
| ER 25 | 411016006-40 00675000934 | 1:1 | EC |
| ER 25 | 411016024-40 00675000934 | 1:1 | IC 80 bar |
| ER 16 | 411010012-40 00675000936 | 1:2 | EC |
| ER 16 | 411010013-40 00675000936 | 1:2 | IC 80 bar |

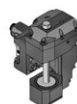

滚齿刀座, Trifix®

| | | | |
|---------|--------------------|-----|----|
| 16-1 型式 | 411500041-40L | 1:1 | EC |
| 16-1 型式 | 411500037-40L | 2:1 | EC |
| | 00675000928 | | |
| | 160016161 Ø 16 | | |
| | 160022161 Ø 22 | | |
| | 160027161 Ø 27 | | |
| | 160015161 Ø 5/8" | | |
| | 160019161 Ø 3/4" | | |
| | 160025161 Ø 1" | | |
| | 160031161 Ø 1 1/4" | | |
| | 110587 | | |



圆盘铣刀刀座

| | | | |
|---------|-----------------------------|---------|----|
| 14-2 型式 | 410900013-40 00675000460 | 2,615:1 | EC |
| | 160016142 Ø 16 | | |
| | 160022142 Ø 22 | | |
| | 160027142 Ø 27 | | |
| | 160015142 Ø 5/8" | | |
| | 160019142 Ø 3/4" | | |
| | 160023142 Ø 7/8" | | |
| | 160025142 Ø 1" | | |



滚齿刀座, Trifix®

| | | | |
|---------|--------------------|-----|----|
| 16-1 型式 | 411500041-40R | 1:1 | EC |
| 16-1 型式 | 411500037-40R | 2:1 | EC |
| | 110587 | | |
| | 160031161 Ø 1 1/4" | | |
| | 160022161 Ø 22 | | |
| | 160016161 Ø 16 | | |
| | 00675000928 | | |
| | 160027161 Ø 27 | | |
| | 160025161 Ø 1" | | |
| | 160019161 Ø 3/4" | | |
| | 160015161 Ø 5/8" | | |

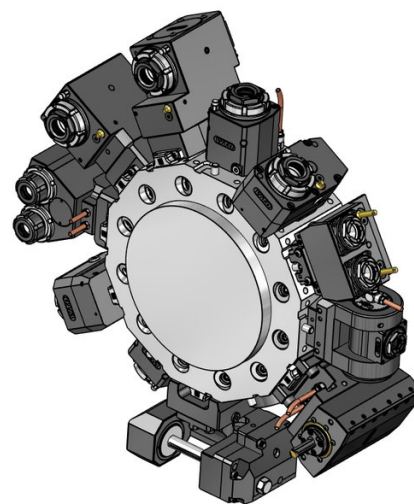
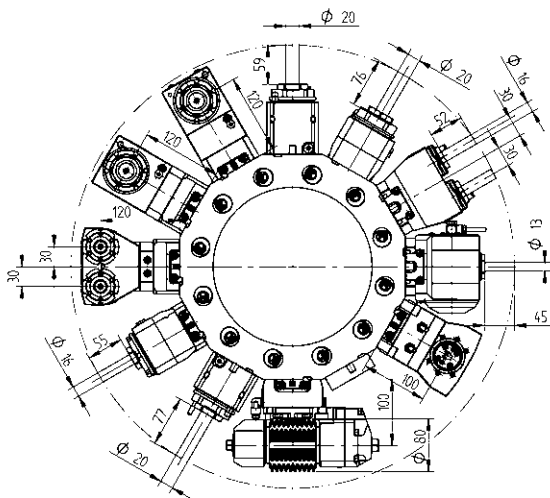

动力刀座 - 扩展产品目录

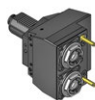

直结式钻/铣刀座, 2刀位, Y-轴

ER 25 413002034-40 1:1,5 EC

00675000930

ER 25 413002035-40 1:1,5 IC 80 bar

00675000930

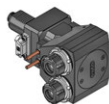

二轴直角式钻/铣动力刀座, Y-轴, LF=120, Trifix®

ER 25 413502024-40L 1:1 EC

00675000915

ER 25 413502025-40L 1:1 IC 80 bar

00675000915

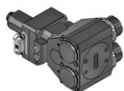

二轴直角式钻/铣动力刀座, Y-轴, LF=120, Trifix®

ER 25 413502024-40R 1:1 EC

00675000915

ER 25 413502025-40R 1:1 IC 80 bar

00675000915

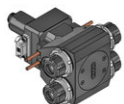

二轴直角式钻/铣动力刀座, 两侧的, Y-轴, LF=120, Trifix®

ER 25 413502026-40 1:1 EC

00675000915



插槽刀座(内外径通用), 两面齿轮, LF=120

32 型式 414532013-40 1:1 EC

动力刀座 - 扩展产品目录

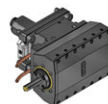

插槽刀座 (内外径通用), Trifix®, LF=100 - BMT

32 型式 414532007-40L 1:1 EC

52 型式 414552001-40L 1:1 EC



插槽刀座 (内外径通用), Trifix®, LF=100 - BMT

32 型式 414532007-40R 1:1 EC

52 型式 414552001-40R 1:1 EC

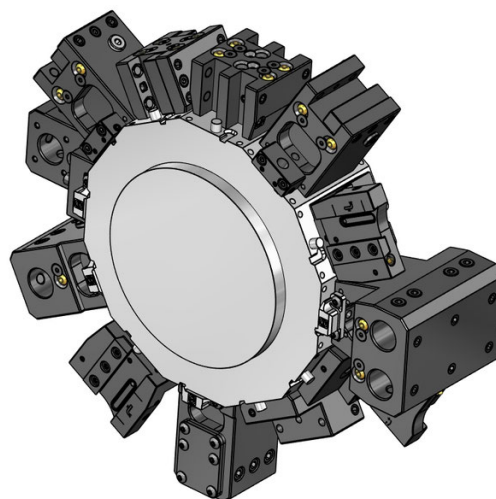
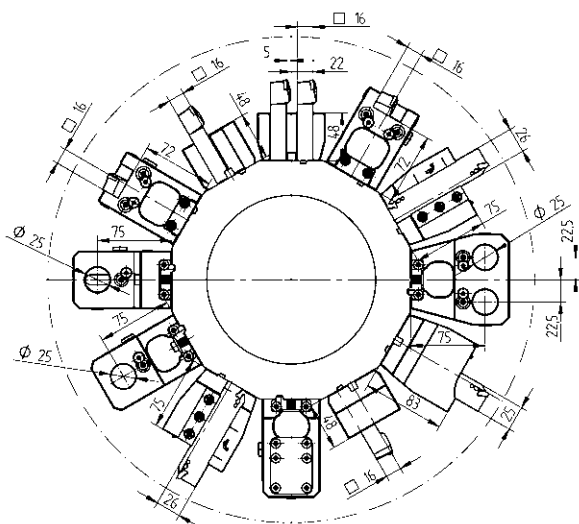

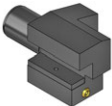

固定刀座 - 标准产品目录

- 

16(12) 方形刀柄轴向刀座, 右手刀, C1型式
48-C1-25x16
- 

16(12) 方形刀柄轴向刀座, 左手刀, C2型式
48-C2-25x16
- 

16(12) 方形刀柄轴向刀座, 右手反刀, C3型式
48-C3-25x16
- 

16(12) 方形刀柄轴向刀座, 左手反刀, C4型式
48-C4-25x16
- 

16 车端面 and 车削刀座 - VDI两面齿轮
48-88237
R2Z415W
- 

20 端面车刀座, 高压内冷 - VDI两面齿
48-106423-HP IC 80 bar
- 

16 车端面 and 车削刀座, 两侧的
48-71572
R2Z810W

固定刀座 - 标准产品目录

- 

20 车端面 and 车削刀座, 两侧的, HP-IC
48-111171-HP IC 80 bar
- 

16 车端面 and 镗削刀座
48-74693
- 

Ø 25 组合刀座, 通用的
48-74687
241125016 ER25
- 

Ø 25 组合刀座, 通用的, Trifix®
48-98234
241125016 ER25
- 

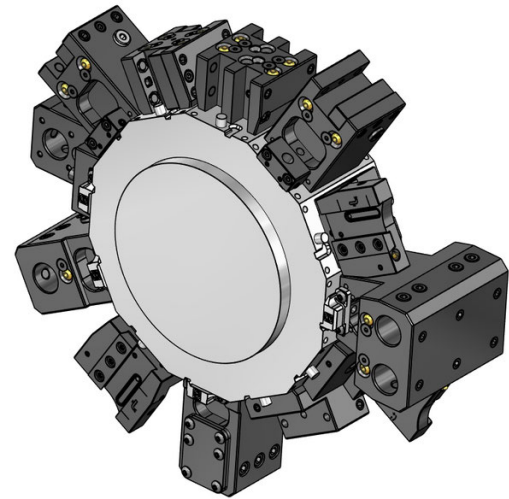
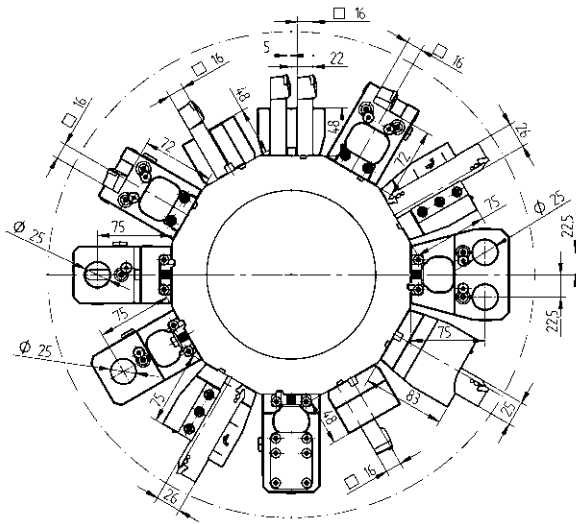

Ø 25 组合刀座, 后缩式, 左手刀
48-74689
241125016 ER25
- 

Ø 25 组合刀座, 后缩式, 左手刀, Trifix®
48-98235
241125016 ER25



固定刀座 - 标准产品目录

 组合刀座, 后缩式, 右手刀
 Ø 25 48-74688
 241125016 ER25

 组合刀座, 后缩式, 右手刀, Trifix®
 Ø 25 48-98236
 241125016 ER25

 组合刀座, 两侧的
 Ø 25 48-74690

 组合刀座, 两侧的, Trifix®
 Ø 25 48-98238

固定刀座 - 扩展产品目录

 车端面 and 车削刀座, 两侧的, 2刀位, Y-轴
 16(5/8") 48-77394
 442770W

 车端面 and 镗削刀座, HP-IC - VDI两面齿轮
 20 48-107434-HP IC 80 bar

 切断刀用刀座, 可调节的 - VDI两面齿轮
 SH 26 48-98981
 R2Z452W

 切断刀用刀座, 可调节的, 内部切削液供应, HP-IC - VDI两面齿轮
 SH 26 48-102647R IC 80 bar
 SH 26 48-102647L IC 80 bar
 SH 32 48-106937R IC 80 bar
 343-810100R80
 SH 32 48-106937L IC 80 bar
 343-810100L80

 组合刀座, 2刀位, 两侧的
 Ø 25 48-119657

 组合刀座, 2刀位, 两侧的, Trifix®
 Ø 25 48-109204

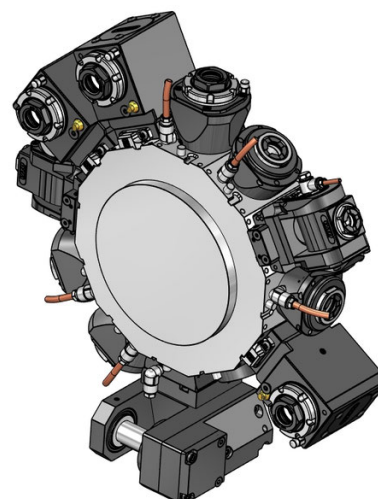
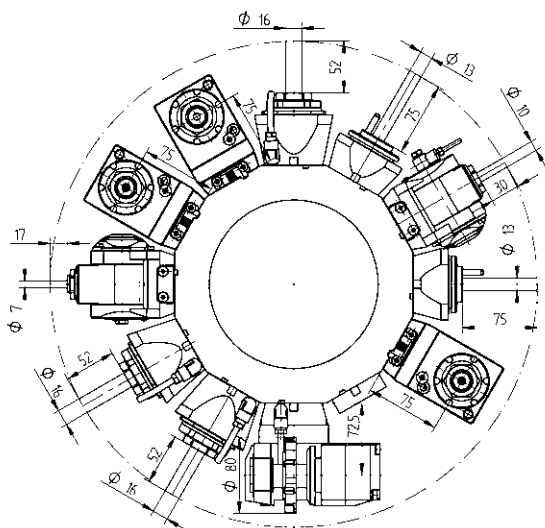

动力刀座 - QuickFlex®



直结式钻/铣动力刀座

- | | | | |
|----------|-------------------------|-----|-----------|
| ER-25 QF | 420125010-25 R2Z471W | 1:1 | EC |
| | 0067725010 | | |
| ER-25 QF | 420125011-25 | 1:1 | IC 80 bar |
| | 0067725010 | | |

动力刀座 - QuickFlex®



直角后缩式钻/铣动力刀座, Trifix®

- | | | | |
|----------|---------------|-----|-----------|
| ER-25 QF | 420525027-25R | 1:1 | EC |
| | 0067725010 | | |
| ER-25 QF | 420525028-25R | 1:1 | IC 80 bar |
| | 0067725010 | | |



直角式钻/铣动力刀座, Trifix®

- | | | | |
|----------|---------------|-----|-----------|
| ER-25 QF | 420525010-25L | 1:1 | EC |
| | 0067725010 | | |
| ER-25 QF | 420525011-25L | 1:1 | IC 80 bar |
| | 0067725010 | | |



直角式钻/铣动力刀座, 两侧的, Trifix®

- | | | | |
|----------|--------------|-----|----|
| ER-25 QF | 420525012-25 | 1:1 | EC |
| | 0067725010 | | |



直角式钻/铣动力刀座, Trifix®

- | | | | |
|----------|---------------|-----|-----------|
| ER-25 QF | 420525010-25R | 1:1 | EC |
| | 0067725010 | | |
| ER-25 QF | 420525011-25R | 1:1 | IC 80 bar |
| | 0067725010 | | |



直角后缩式钻/铣动力刀座, Trifix®

- | | | | |
|----------|---------------|-----|-----------|
| ER-25 QF | 420525027-25L | 1:1 | EC |
| | 0067725010 | | |
| ER-25 QF | 420525028-25L | 1:1 | IC 80 bar |
| | 0067725010 | | |

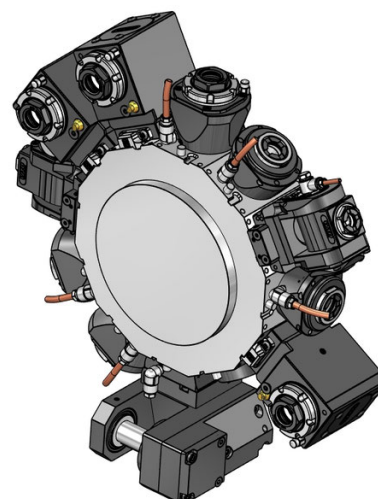
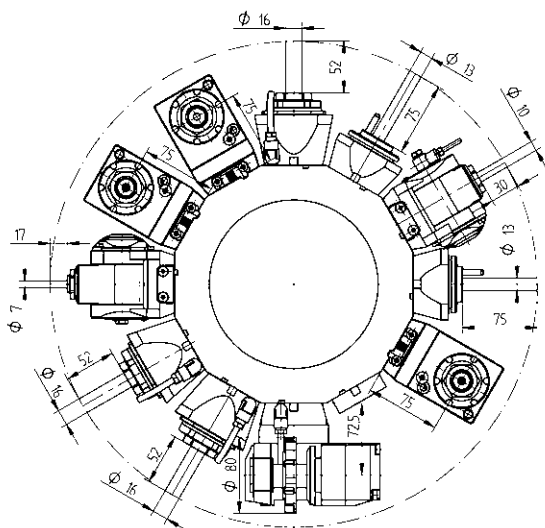

动力刀座 - 扩展产品目录



直结式钻/铣动力刀座, 短型

ER 20 410113004-25 1:1 EC
R2Z490
00675000700



直结式铣刀座 - 组合铣刀心轴, DIN6358

Ø 16 410216003-25 1:1 EC
00675000854

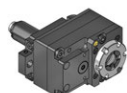

直结偏位式钻/铣动力刀座

ER 25 410116017-25 1:1 EC
00675000801
ER 20 410113003-25 1:2 EC
00675000887
ER 16 410410000-25 1:3 EC
00675000636
ER 25 410116013-25 2:1 EC
00675000801

动力刀座 - 扩展产品目录



直角式钻/铣动力刀座

ER-20 QF 420520019-25 1:2 EC
0067720011
ER-20 QF 420520020-25 1:2 IC 80 bar
0067720011
ER 16 410810012-25 1:3 EC
00675000841
ER 16 410810013-25 1:3 IC 80 bar
00675000841
ER-25 QF 420525032-25 2:1 EC
0067725010
ER-25 QF 420525033-25 2:1 IC 80 bar
0067725010



直角式铣动力刀座 - 组合铣刀心轴, DIN6358

Ø 16 410616002-25 1:1 EC
00675000854
Ø 22 410622005-25 2:1 EC
00675000483
Ø 27 410627002-25 2:1 EC
00675000245

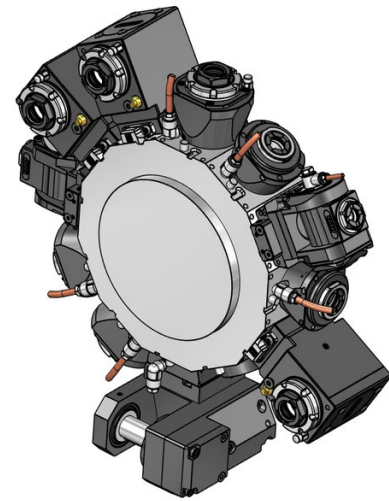
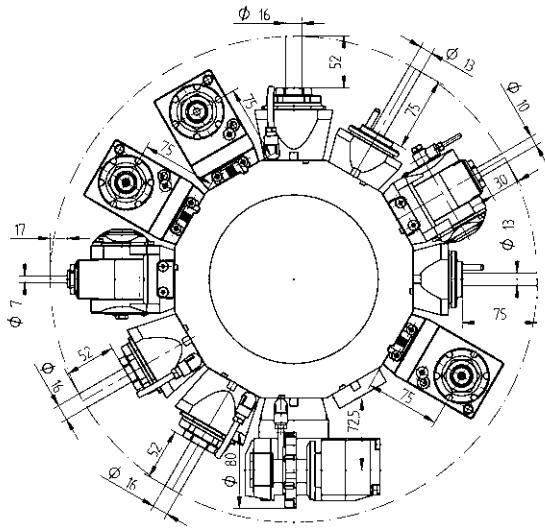

动力刀座 - 扩展产品目录



可调角度钻/铣动力刀座

| | | | |
|-------|-----------------------------|-----|-----------|
| ER 16 | 411010003-25 00675000902 | 1:1 | EC |
| ER 16 | 411010010-25 00675000902 | 1:1 | IC 80 bar |
| ER 11 | 411007006-25 00675000914 | 1:2 | EC |
| ER 11 | 411007007-25 00675000914 | 1:2 | IC 80 bar |



横向圆盘式铣刀刀座

| | | |
|---------|-----------------------------|-----------|
| 14-2 型式 | 411500002-25 00675000460 | 2,727:1EC |
| | 160016142 Ø 16 | |
| | 160022142 Ø 22 | |
| | 160027142 Ø 27 | |
| | 160015142 Ø 5/8" | |
| | 160019142 Ø 3/4" | |
| | 160023142 Ø 7/8" | |
| | 160025142 Ø 1" | |

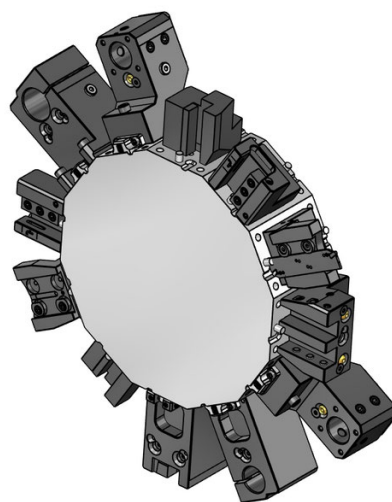
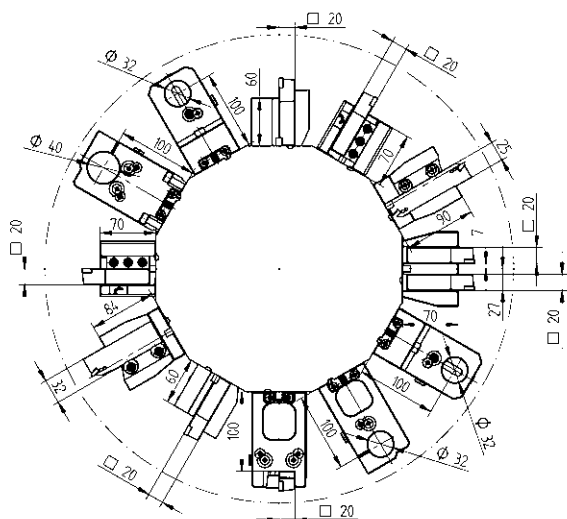

固定刀座 - 标准产品目录

- 

方形刀柄轴向刀座, 右手刀, C1型式
20(16) 48-C1-30x20
- 

方形刀柄轴向刀座, 左手刀, C2型式
20(16) 48-C2-30x20
- 

方形刀柄轴向刀座, 右手反刀, C3型式
20(16) 48-C3-30x20
- 

方形刀柄轴向刀座, 左手反刀, C4型式
20(16) 48-C4-30x20
- 

方形刀柄刀座, D1 型式
20(16) 48-D1-30x20
- 

方形刀柄刀座, 反刀, D2 型式
20(16) 48-D2-30x20
- 

车端面 and 车削刀座, 左手刀
20 48-71932 R4Z410W

固定刀座 - 标准产品目录

- 

车端面 and 车削刀座, 右手刀
20 48-72047 R4Z230W
- 

车端面 and 车削刀座, 两侧的
20 48-71216 R6Z410W
- 

车端面 and 镗削刀座
20 48-105756
- 

车端面 and 镗削刀座, Trifix®
20 48-109793
- 

组合刀座, 通用的, LF=100
Ø 32 48-71434
241132016 ER25
241132020 ER32
- 

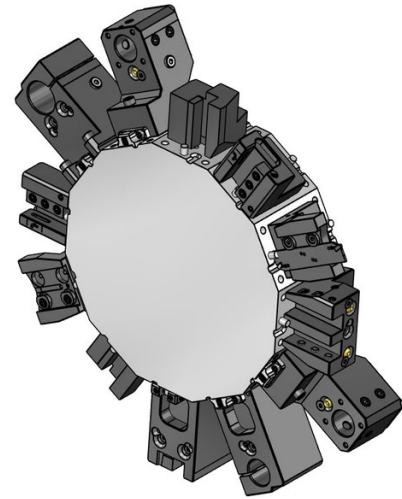
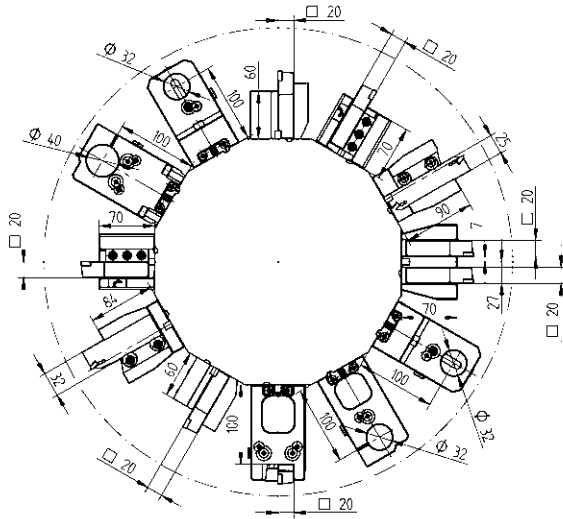

组合刀座, 通用的, Trifix®, LF=100
Ø 32 48-96995
241132016 ER25
241132020 ER32





固定刀座 - 标准产品目录

固定刀座 - 标准产品目录





组合刀座, 后缩式, 左手刀, LF=100
 Ø 32 48-71438
 241132016 ER25
 241132020 ER32





组合刀座, 后缩式, 左手刀, Trifix®, LF=100
 Ø 32 48-97531
 241132016 ER25
 241132020 ER32



组合刀座, 后缩式, 右手刀, LF=100
 Ø 32 48-71436
 241132016 ER25
 241132020 ER32



组合刀座, 后缩式, 右手刀, Trifix®, LF=100
 Ø 32 48-97553
 241132016 ER25
 241132020 ER32



筒夹刀座, LF=100
 ER 32 48-82824 IC 80 bar
 107532000



筒夹刀座, Trifix®, LF=100
 ER 32 48-100198 IC 80 bar
 107532000



筒夹刀座, 两侧的, LF=100
 ER 32 48-82847 IC 80 bar
 107532000

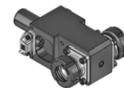

筒夹刀座, 两侧的, Trifix®, LF=100
 ER 32 48-100199 IC 80 bar
 107532000



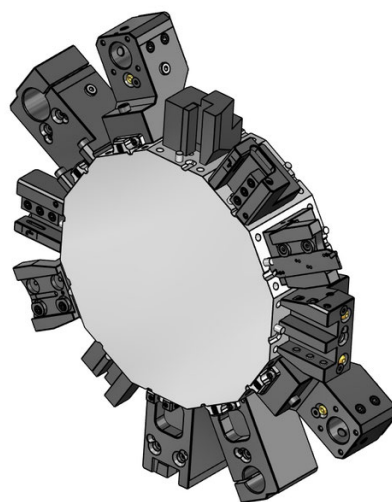
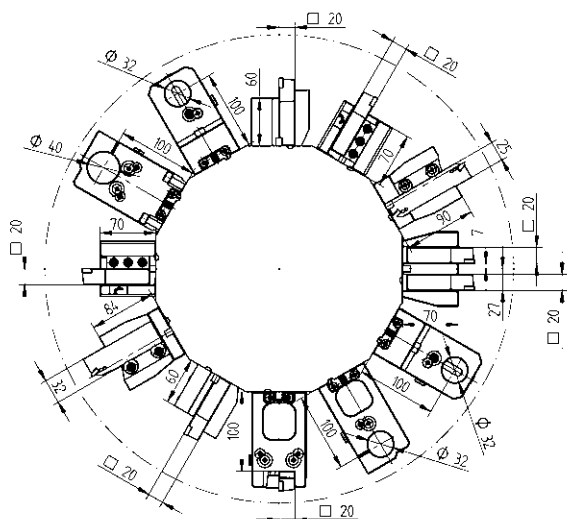

防污塞, 钢材, Z2型式
 钢材 48-Z2-30-S



固定刀座 - 扩展产品目录

 端面车刀座, 高压内冷 - VDI两面齿
20 48-105977-HP IC 80 bar

 车端面 and 车削刀座, 两侧的, HP-IC
20 48-71216-HP IC 80 bar

 车端面 and 车削刀座, 2刀位, Y-轴 - VDI两面齿
20 (3/4") 48-84593

 车端面 and 车削刀座, 两侧的, 2刀位, Y-轴
20 (3/4") 48-77395
442750W

 切断刀用刀座, 可调节的 - VDI两面齿
SH 26 48-98991
R4Z451W
SH 32 48-99017
R9Z450

 切断刀用刀座, 可调节的, 内部切削液供应, HP-IC - VDI两面齿
SH 26 48-102630R IC 80 bar
343-810100R42
SH 26 48-102630L IC 80 bar
343-810100L42
SH 32 48-102632R IC 80 bar
SH 32 48-102632L IC 80 bar



固定刀座 - 扩展产品目录



 组合刀座, 通用的, Trifix®, LF=100 - BMT
Ø 40 48-99669
 241140020 ER32
 241140026 ER40

 镗刀刀座, 带槽, LF=100
Ø 32 48-87088

 镗刀刀座, 带槽, Trifix®, LF=100
Ø 32 48-97588

 镗刀刀座, 带槽, Trifix®, LF=100 - BMT
Ø 40 48-96994

 组合刀座, 通用的, 2刀位, Y-轴, LF=100
Ø 25 48-79026
 241125016 ER25

 组合刀座, 通用的, 2刀位, Y-轴, LF=100, Trifix®
Ø 25 48-99635
 241125016 ER25

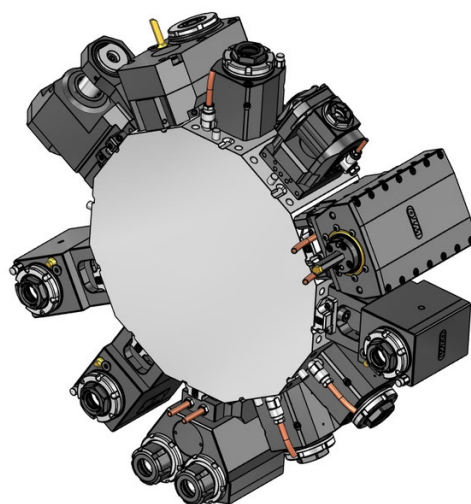
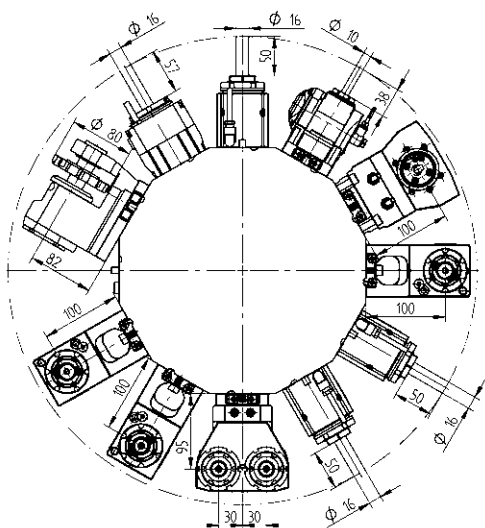

动力刀座 - QuickFlex®



直结式钻/铣动力刀座 (6000 RPM)

ER-25 QF 420125010-30L 1:1 EC
440441W



ER-25 QF 420125019-30L 1:1 IC 80 bar
0067725010



直结式钻/铣动力刀座 (12000 RPM)

ER-25 QF 420125014-30L 1:1 EC
0067725010

ER-25 QF 420125015-30L 1:1 IC 80 bar
0067725010



直角式钻/铣动力刀座, Trifix®, (6000 RPM)

ER-25 QF 420525055-30L 1:1 EC
0067725010

ER-25 QF 420525056-30L 1:1 IC 80 bar
0067725010



直角式钻/铣动力刀座, Trifix®, (12000 RPM)

ER-25 QF 420525057-30L 1:1 EC
0067725010

ER-25 QF 420525058-30L 1:1 IC 80 bar
0067725010

动力刀座 - QuickFlex®



直角式钻/铣动力刀座, Trifix®, (6000 RPM)

ER-25 QF 420525055-30R 1:1 EC
0067725010

ER-25 QF 420525056-30R 1:1 IC 80 bar
0067725010



直角式钻/铣动力刀座, Trifix®, (12000 RPM)

ER-25 QF 420525057-30R 1:1 EC
0067725010

ER-25 QF 420525058-30R 1:1 IC 80 bar
0067725010



直角后缩式钻/铣动力刀座, Trifix®, (6000 RPM)

ER-25 QF 420525089-30L 1:1 EC
0067725010

ER-25 QF 420525090-30L 1:1 IC 80 bar
0067725010



直角后缩式钻/铣动力刀座, Trifix®, (12000 RPM)

ER-25 QF 420525060-30L 1:1 EC
0067725010

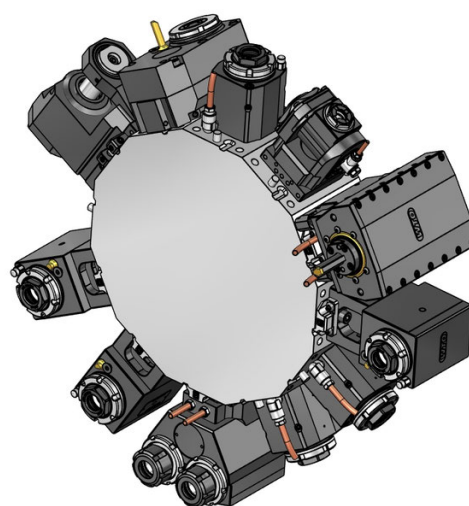
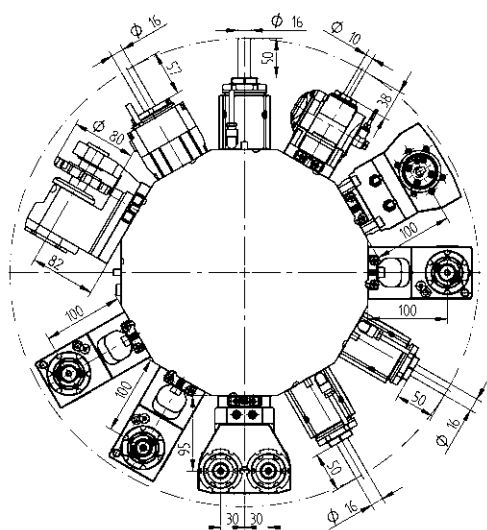

ER-25 QF 420525061-30L 1:1 IC 80 bar
0067725010



动力刀座 - QuickFlex®



- 

直角后缩式钻/铣动力刀座, Trifix®, (6000 RPM)

| | | | |
|----------|--|-----|-----------|
| ER-25 QF | 420525089-30R | 1:1 | EC |
| |  0067725010 | | |
| ER-25 QF | 420525090-30R | 1:1 | IC 80 bar |
| |  0067725010 | | |

- 

直角后缩式钻/铣动力刀座, Trifix®, (12000 RPM)

| | | | |
|----------|--|-----|-----------|
| ER-25 QF | 420525060-30R | 1:1 | EC |
| |  0067725010 | | |
| ER-25 QF | 420525061-30R | 1:1 | IC 80 bar |
| |  0067725010 | | |

- 

直角式钻/铣动力刀座, 两侧的, Trifix®, (6000 RPM)

| | | | |
|----------|--|-----|----|
| ER-25 QF | 420525086-30 | 1:1 | EC |
| |  0067725010 | | |

- 

直角式钻/铣动力刀座, 两侧的, Trifix®, (12000 RPM)

| | | | |
|----------|--|-----|----|
| ER-25 QF | 420525095-30 | 1:1 | EC |
| |  0067725010 | | |

动力刀座 - 扩展产品目录

- 

直结式钻/铣动力刀座 - BMT

| | | | |
|----------|--|-----|-----------|
| ER-32 QF | 420132010-30 | 1:1 | EC |
| |  0067732000 | | |
| ER-32 QF | 420132011-30 | 1:1 | IC 80 bar |
| |  0067732000 | | |

- 

直结式铣刀座

| | | | |
|------|---|-----|----|
| Ø 16 | 410216014-30 | 1:1 | EC |
| |  00675000854 | | |

- 

直结偏位式钻/铣动力刀座

| | | | |
|-------|---|-----|-----------|
| ER 25 | 410116058-30 | 1:1 | EC |
| |  00675000801 | | |
| ER 25 | 410116057-30 | 1:1 | IC 80 bar |
| |  00675000801 | | |
| ER 20 | 410113010-30 | 1:2 | EC |
| |  00675000591 | | |
| ER 20 | 410113009-30 | 1:2 | IC 80 bar |
| |  00675000591 | | |
| ER 25 | 410116059-30 | 2:1 | EC |
| |  00675000801 | | |
| ER 25 | 410116060-30 | 2:1 | IC 80 bar |
| |  00675000801 | | |
| ER 32 | 410120027-30 | 2:1 | EC |
| |  00675000592 | | |
| ER 32 | 410120032-30 | 2:1 | IC 80 bar |
| |  00675000592 | | |

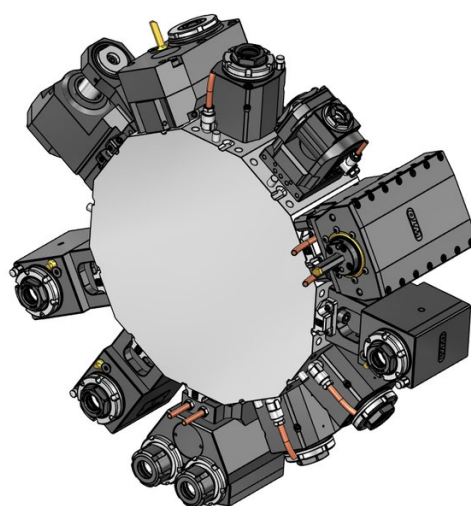
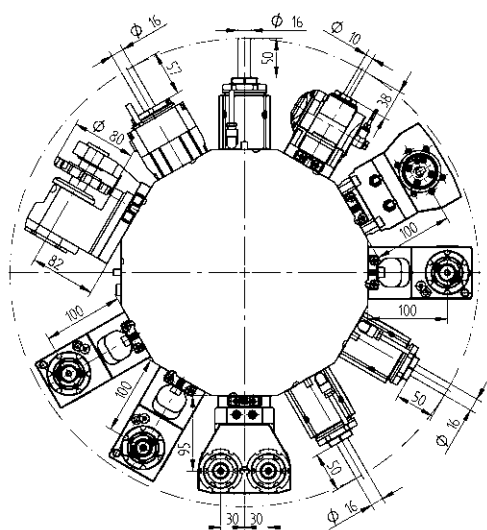

动力刀座 - 扩展产品目录



直结偏位式钻/铣动力刀座 - VDI两面齿轮

ER 16 410410002-30 1:3 EC
 00675000937

ER 16 410410001-30 1:3 IC 80 bar
 00675000937



直角式钻/铣动力刀座

ER-20 QF 420520013-30 1:2 EC
 0067720011

ER-20 QF 420520014-30 1:2 IC 80 bar
 0067720011

ER 16 410810012-30 1:3 EC
 00675000841

ER 16 410810013-30 1:3 IC 80 bar
 00675000841

ER-25 QF 420525096-30 2:1 EC
 0067725010

ER-25 QF 420525097-30 2:1 IC 80 bar
 0067725010



直角式钻/铣动力刀座, Trifix®

ER-20 QF 420520015-30L 1:2 EC
 0067720011

ER-20 QF 420520016-30L 1:2 IC 80 bar
 0067720011

动力刀座 - 扩展产品目录



直角后缩式钻/铣动力刀座

ER 32 410520013-30 2:1 EC
 00675000592

ER 32 410520014-30 2:1 IC 80 bar
 00675000592



可调角度钻/铣动力刀座

ER 16 411010015-30 1:1 EC
 00675000902

ER 16 411010016-30 1:1 IC 80 bar
 00675000902

ER 11 411007018-30 1:2 EC
 00675000914

ER 11 411007019-30 1:2 IC 80 bar
 00675000914

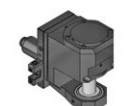

圆盘铣刀刀座

14-2 型式 410900015-30 2,615:1EC
 00675000460

160016142 Ø 16

160022142 Ø 22

160027142 Ø 27

160015142 Ø 5/8"

160019142 Ø 3/4"

160023142 Ø 7/8"

160025142 Ø 1"

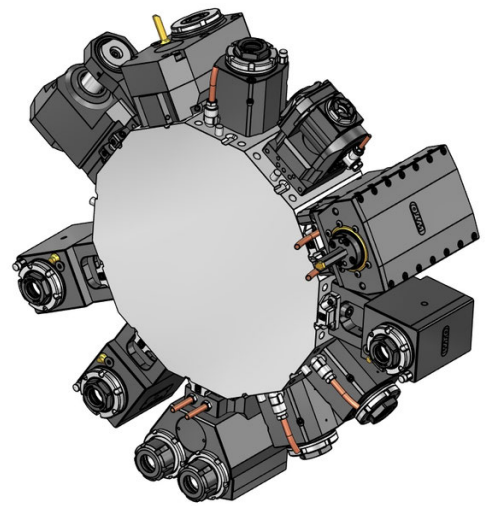
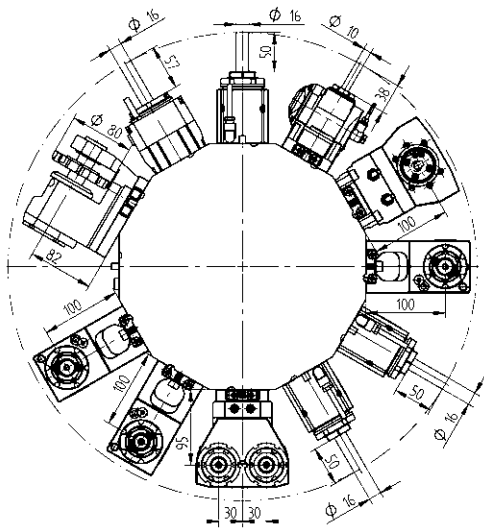

动力刀座 - 扩展产品目录

动力刀座 - 扩展产品目录



滚齿刀座, Trifix®

15-2 型式 410900025-30 1:1 EC

00675001015

160008152 Ø 8

160010152 Ø 10

160013152 Ø 13

160016152 Ø 16

160022152 Ø 22

160015152 Ø 5/8"

160019152 Ø 3/4"

110587



二轴直角式钻/铣动力刀座, 两侧的, Y-轴

ER 25 413502009-30 1:1 EC

00675000915



插槽刀座 (内外径通用), Trifix® - BMT

32 型式 414532001-30L 1:1 EC



插槽刀座 (内外径通用), Trifix® - BMT

32 型式 414532001-30R 1:1 EC



直结式钻/铣刀座, 2刀位, Y-轴

ER 25 413002008-30 1:1,5 EC

00675000930

ER 25 413002009-30 1:1,5 IC 80 bar

00675000930



二轴直角式钻/铣动力刀座, Y-轴

ER 25 413502000-30 1:1 EC

00675000915

ER 25 413502004-30 1:1 IC 80 bar

00675000915

标准规格套筒 - 圆柱形

| | | |
|---|-----------|------|
|  | 变径套 Ø 20 | |
| | 240020006 | ø 6 |
| | 240020008 | ø 8 |
| | 240020010 | ø 10 |
| | 240020012 | ø 12 |
| | 240020014 | ø 14 |
| 240020016 | ø 16 | |

| | | |
|---|-----------|------|
|  | 变径套 Ø 25 | |
| | 240025006 | ø 6 |
| | 240025008 | ø 8 |
| | 240025010 | ø 10 |
| | 240025012 | ø 12 |
| | 240025014 | ø 14 |
| | 240025016 | ø 16 |
| 240025020 | ø 20 | |

| | | |
|---|-----------|------|
|  | 变径套 Ø 32 | |
| | 240032006 | ø 6 |
| | 240032008 | ø 8 |
| | 240032010 | ø 10 |
| | 240032012 | ø 12 |
| | 240032014 | ø 14 |
| | 240032016 | ø 16 |
| | 240032018 | ø 18 |
| | 240032020 | ø 20 |
| 240032025 | ø 25 | |

| | | |
|---|-----------|------|
|  | 变径套 Ø 40 | |
| | 240040006 | ø 6 |
| | 240040008 | ø 8 |
| | 240040010 | ø 10 |
| | 240040012 | ø 12 |
| | 240040014 | ø 14 |
| | 240040016 | ø 16 |
| | 240040020 | ø 20 |
| | 240040025 | ø 25 |
| | 240040032 | ø 32 |

| | | |
|---|-----------|------|
|  | 变径套 Ø 50 | |
| | 240050010 | ø 10 |
| | 240050012 | ø 12 |
| | 240050016 | ø 16 |
| | 240050020 | ø 20 |
| | 240050025 | ø 25 |
| | 240050032 | ø 32 |
| | 240050040 | ø 40 |

标准规格套筒 - 圆柱形, 带槽

| | | |
|---|-----------|------|
|  | 变径套 Ø 25 | |
| | 240125006 | ø 6 |
| | 240125008 | ø 8 |
| | 240125010 | ø 10 |
| | 240125012 | ø 12 |
| | 240125014 | ø 14 |
| | 240125015 | ø 15 |
| | 240125016 | ø 16 |
| 240125020 | ø 20 | |

| | | |
|---|-----------|------|
|  | 变径套 Ø 32 | |
| | 240132008 | ø 8 |
| | 240132010 | ø 10 |
| | 240132012 | ø 12 |
| | 240132015 | ø 15 |
| | 240132016 | ø 16 |
| | 240132020 | ø 20 |
| | 240132025 | ø 25 |

| | | |
|--|-----------|------|
|  | 变径套 Ø 40 | |
| | 240140010 | ø 10 |
| | 240140012 | ø 12 |
| | 240140015 | ø 15 |
| | 240140016 | ø 16 |
| | 240140020 | ø 20 |
| | 240140025 | ø 25 |
| | 240140032 | ø 32 |

标准规格套筒 - 莫氏锥度



变径套 Ø 32

| | |
|-----------|------|
| 240532001 | MT 1 |
| 240532002 | MT 2 |
| 240532003 | MT 3 |

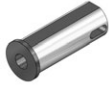

变径套 Ø 40

| | |
|-----------|------|
| 240540001 | MT 1 |
| 240540002 | MT 2 |
| 240540003 | MT 3 |
| 240540004 | MT 4 |

筒夹 DIN 6499B (ER/ESX)



ER 11

| | | |
|-----------|---------|---------------|
| 190011000 | ø 7-0.5 | ø 0.276-0.020 |
| 190011010 | ø 1-0.5 | ø 0.039-0.020 |
| 190011015 | ø 1.5-1 | ø 0.059-0.039 |
| 190011020 | ø 2-1.5 | ø 0.079-0.059 |
| 190011025 | ø 2.5-2 | ø 0.098-0.079 |
| 190011030 | ø 3-2.5 | ø 0.118-0.098 |
| 190011035 | ø 3.5-3 | ø 0.138-0.118 |
| 190011040 | ø 4-3.5 | ø 0.158-0.138 |
| 190011045 | ø 4.5-4 | ø 0.177-0.158 |
| 190011050 | ø 5-4.5 | ø 0.197-0.177 |
| 190011055 | ø 5.5-5 | ø 0.217-0.197 |
| 190011060 | ø 6-5.5 | ø 0.236-0.217 |
| 190011065 | ø 6.5-6 | ø 0.256-0.236 |
| 190011070 | ø 7-6.5 | ø 0.276-0.256 |



ER 16

| | | |
|-----------|----------|---------------|
| 190016000 | ø 10-0.5 | ø 0.394-0.020 |
| 190016010 | ø 1-0.5 | ø 0.039-0.020 |
| 190016020 | ø 2-1 | ø 0.079-0.039 |
| 190016030 | ø 3-2 | ø 0.118-0.079 |
| 190016040 | ø 4-3 | ø 0.158-0.118 |
| 190016050 | ø 5-4 | ø 0.197-0.158 |
| 190016060 | ø 6-5 | ø 0.236-0.197 |
| 190016070 | ø 7-6 | ø 0.276-0.236 |
| 190016080 | ø 8-7 | ø 0.315-0.276 |
| 190016090 | ø 9-8 | ø 0.354-0.315 |
| 190016100 | ø 10-9 | ø 0.394-0.354 |



ER 20

| | | |
|-----------|---------|---------------|
| 190020000 | ø 13-1 | ø 0.512-0.039 |
| 190020010 | ø 1-0.5 | ø 0.039-0.020 |
| 190020020 | ø 2-1 | ø 0.079-0.039 |
| 190020030 | ø 3-2 | ø 0.118-0.079 |
| 190020040 | ø 4-3 | ø 0.157-0.118 |
| 190020050 | ø 5-4 | ø 0.197-0.157 |
| 190020060 | ø 6-5 | ø 0.236-0.197 |
| 190020070 | ø 7-6 | ø 0.276-0.236 |
| 190020080 | ø 8-7 | ø 0.315-0.276 |
| 190020090 | ø 9-8 | ø 0.354-0.315 |
| 190020100 | ø 10-9 | ø 0.394-0.354 |
| 190020110 | ø 11-10 | ø 0.433-0.394 |
| 190020120 | ø 12-11 | ø 0.472-0.433 |
| 190020130 | ø 13-12 | ø 0.512-0.472 |

筒夹 DIN 6499B (ER/ESX)



ER 25

| | | |
|-----------|---------|---------------|
| 190025000 | ø 16-1 | ø 0.630-0.039 |
| 190025010 | ø 1-0.5 | ø 0.039-0.020 |
| 190025020 | ø 2-1 | ø 0.079-0.039 |
| 190025030 | ø 3-2 | ø 0.118-0.079 |
| 190025040 | ø 4-3 | ø 0.157-0.118 |
| 190025050 | ø 5-4 | ø 0.197-0.157 |
| 190025060 | ø 6-5 | ø 0.236-0.197 |
| 190025070 | ø 7-6 | ø 0.276-0.236 |
| 190025080 | ø 8-7 | ø 0.315-0.276 |
| 190025090 | ø 9-8 | ø 0.354-0.315 |
| 190025100 | ø 10-9 | ø 0.394-0.354 |
| 190025110 | ø 11-10 | ø 0.433-0.394 |
| 190025120 | ø 12-11 | ø 0.472-0.433 |
| 190025130 | ø 13-12 | ø 0.512-0.472 |
| 190025140 | ø 14-13 | ø 0.551-0.512 |
| 190025150 | ø 15-14 | ø 0.591-0.551 |
| 190025160 | ø 16-15 | ø 0.630-0.591 |



ER 32

| | | |
|-----------|---------|---------------|
| 190032000 | ø 20-2 | ø 0.787-0.079 |
| 190032020 | ø 2-1 | ø 0.079-0.039 |
| 190032030 | ø 3-2 | ø 0.118-0.079 |
| 190032040 | ø 4-3 | ø 0.157-0.118 |
| 190032050 | ø 5-4 | ø 0.197-0.157 |
| 190032060 | ø 6-5 | ø 0.236-0.197 |
| 190032070 | ø 7-6 | ø 0.276-0.236 |
| 190032080 | ø 8-7 | ø 0.315-0.276 |
| 190032090 | ø 9-8 | ø 0.354-0.315 |
| 190032100 | ø 10-9 | ø 0.394-0.354 |
| 190032110 | ø 11-10 | ø 0.433-0.394 |
| 190032120 | ø 12-11 | ø 0.472-0.433 |
| 190032130 | ø 13-12 | ø 0.512-0.472 |
| 190032140 | ø 14-13 | ø 0.551-0.512 |
| 190032150 | ø 15-14 | ø 0.591-0.551 |
| 190032160 | ø 16-15 | ø 0.630-0.591 |
| 190032170 | ø 17-16 | ø 0.669-0.630 |
| 190032180 | ø 18-17 | ø 0.709-0.669 |
| 190032190 | ø 19-18 | ø 0.748-0.709 |
| 190032200 | ø 20-19 | ø 0.787-0.748 |

筒夹 DIN 6499B (ER/ESX)



ER 40

| | | |
|-----------|---------|---------------|
| 190040000 | ø 26-3 | ø 1.024-0.118 |
| 190040030 | ø 3-2 | ø 0.118-0.079 |
| 190040040 | ø 4-3 | ø 0.157-0.118 |
| 190040050 | ø 5-4 | ø 0.197-0.157 |
| 190040060 | ø 6-5 | ø 0.236-0.197 |
| 190040070 | ø 7-6 | ø 0.276-0.236 |
| 190040080 | ø 8-7 | ø 0.315-0.276 |
| 190040090 | ø 9-8 | ø 0.354-0.315 |
| 190040100 | ø 10-9 | ø 0.394-0.354 |
| 190040110 | ø 11-10 | ø 0.433-0.394 |
| 190040120 | ø 12-11 | ø 0.472-0.433 |
| 190040130 | ø 13-12 | ø 0.512-0.472 |
| 190040140 | ø 14-13 | ø 0.551-0.512 |
| 190040150 | ø 15-14 | ø 0.591-0.551 |
| 190040160 | ø 16-15 | ø 0.630-0.591 |
| 190040170 | ø 17-16 | ø 0.669-0.630 |
| 190040180 | ø 18-17 | ø 0.709-0.669 |
| 190040190 | ø 19-18 | ø 0.748-0.709 |
| 190040200 | ø 20-19 | ø 0.787-0.748 |
| 190040210 | ø 21-20 | ø 0.827-0.787 |
| 190040220 | ø 22-21 | ø 0.866-0.827 |
| 190040230 | ø 23-22 | ø 0.906-0.866 |
| 190040240 | ø 24-23 | ø 0.945-0.906 |
| 190040250 | ø 25-24 | ø 0.984-0.945 |
| 190040260 | ø 26-25 | ø 1.024-0.984 |



ER 50

| | | |
|-----------|---------|---------------|
| 190050000 | ø 34-10 | ø 1.339-0.394 |
| 190050060 | ø 6-4 | ø 0.236-0.157 |
| 190050080 | ø 8-6 | ø 0.315-0.236 |
| 190050100 | ø 10-8 | ø 0.394-0.315 |
| 190050120 | ø 12-10 | ø 0.472-0.394 |
| 190050140 | ø 14-12 | ø 0.551-0.472 |
| 190050160 | ø 16-14 | ø 0.630-0.551 |
| 190050180 | ø 18-16 | ø 0.709-0.630 |
| 190050200 | ø 20-18 | ø 0.787-0.709 |
| 190050220 | ø 22-20 | ø 0.866-0.787 |
| 190050240 | ø 24-22 | ø 0.945-0.866 |
| 190050260 | ø 26-24 | ø 1.024-0.945 |
| 190050280 | ø 28-26 | ø 1.102-1.024 |
| 190050300 | ø 30-28 | ø 1.181-1.102 |
| 190050320 | ø 32-30 | ø 1.260-1.181 |
| 190050340 | ø 32-30 | ø 1.260-1.181 |

筒夹 DIN 6499D (ER/ESX) - 密封, 为内冷系统



ER 11

| | |
|-----------|-----|
| 191011030 | ø 3 |
| 191011040 | ø 4 |
| 191011050 | ø 5 |
| 191011060 | ø 6 |



ER 16

| | |
|-----------|--------|
| 191016000 | ø 3-10 |
| 191016030 | ø 3 |
| 191016040 | ø 4 |
| 191016050 | ø 5 |
| 191016060 | ø 6 |
| 191016070 | ø 7 |
| 191016080 | ø 8 |
| 191016090 | ø 9 |
| 191016100 | ø 10 |



ER 20

| | |
|-----------|--------|
| 191020000 | ø 3-12 |
| 191020030 | ø 3 |
| 191020040 | ø 4 |
| 191020050 | ø 5 |
| 191020060 | ø 6 |
| 191020070 | ø 7 |
| 191020080 | ø 8 |
| 191020090 | ø 9 |
| 191020100 | ø 10 |
| 191020110 | ø 11 |
| 191020120 | ø 12 |



ER 25

| | |
|-----------|--------|
| 191025000 | ø 4-16 |
| 191025030 | ø 3 |
| 191025040 | ø 4 |
| 191025050 | ø 5 |
| 191025060 | ø 6 |
| 191025070 | ø 7 |
| 191025080 | ø 8 |
| 191025090 | ø 9 |
| 191025100 | ø 10 |
| 191025110 | ø 11 |
| 191025120 | ø 12 |
| 191025130 | ø 13 |
| 191025140 | ø 14 |
| 191025150 | ø 15 |
| 191025160 | ø 16 |

筒夹 DIN 6499D (ER/ESX) - 密封, 为内冷系统



ER 32

| | |
|-----------|--------|
| 191032000 | ø 4-20 |
| 191032030 | ø 3 |
| 191032040 | ø 4 |
| 191032050 | ø 5 |
| 191032060 | ø 6 |
| 191032070 | ø 7 |
| 191032080 | ø 8 |
| 191032090 | ø 9 |
| 191032100 | ø 10 |
| 191032110 | ø 11 |
| 191032120 | ø 12 |
| 191032130 | ø 13 |
| 191032140 | ø 14 |
| 191032150 | ø 15 |
| 191032160 | ø 16 |
| 191032170 | ø 17 |
| 191032180 | ø 18 |
| 191032190 | ø 19 |
| 191032200 | ø 20 |



ER 40

| | |
|-----------|------|
| 191040060 | ø 6 |
| 191040080 | ø 8 |
| 191040100 | ø 10 |
| 191040120 | ø 12 |
| 191040140 | ø 14 |
| 191040160 | ø 16 |
| 191040180 | ø 18 |
| 191040200 | ø 20 |
| 191040220 | ø 22 |
| 191040250 | ø 25 |

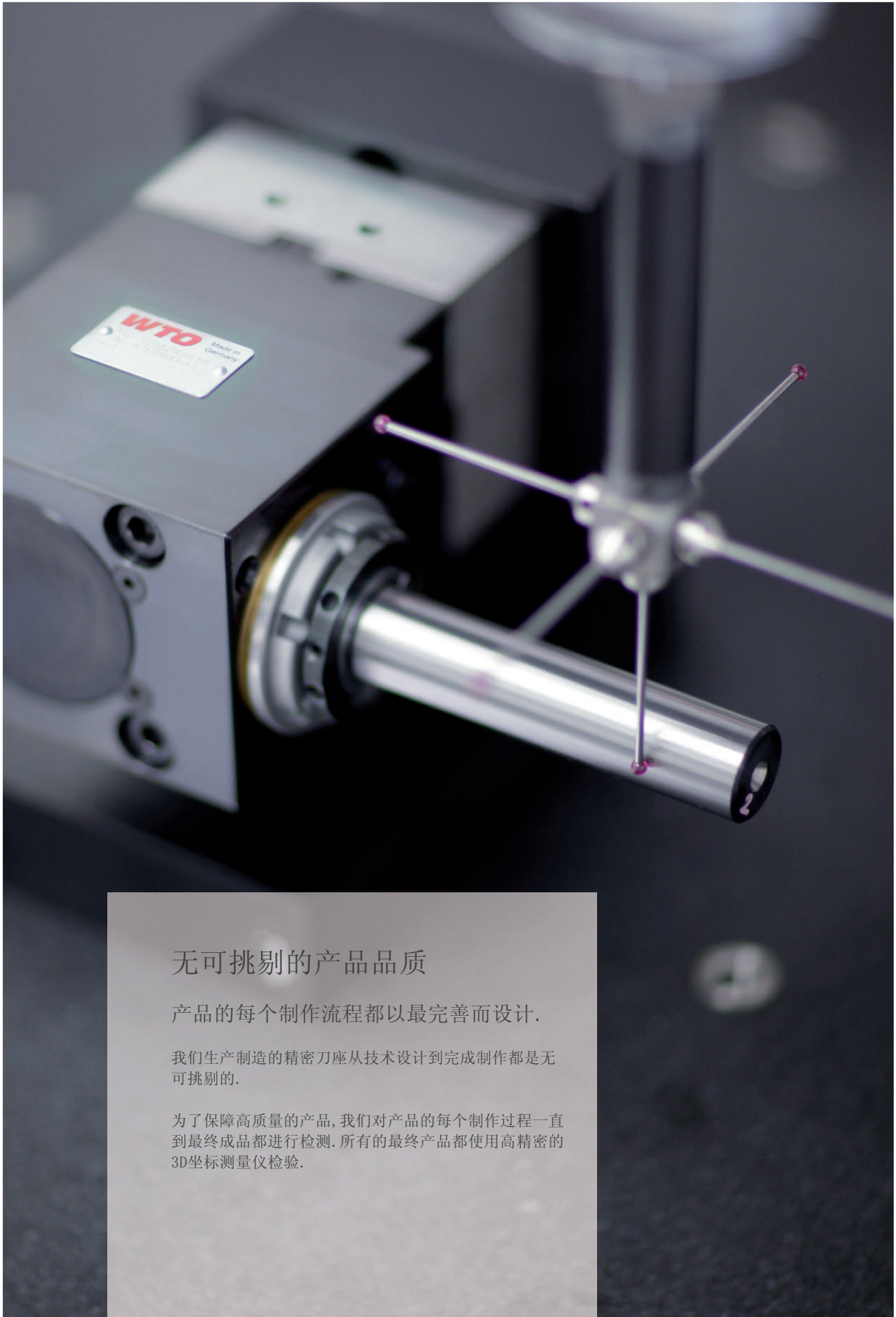

无可挑剔的产品品质

产品的每个制作流程都以最完善而设计。

我们生产制造的精密刀座从技术设计到完成制作都是无可挑剔的。

为了保障高质量的产品,我们对产品的每个制作过程一直到最终成品都进行检测。所有的最终产品都使用高精密的3D坐标测量仪检验。

WTO 全球分布

WTO

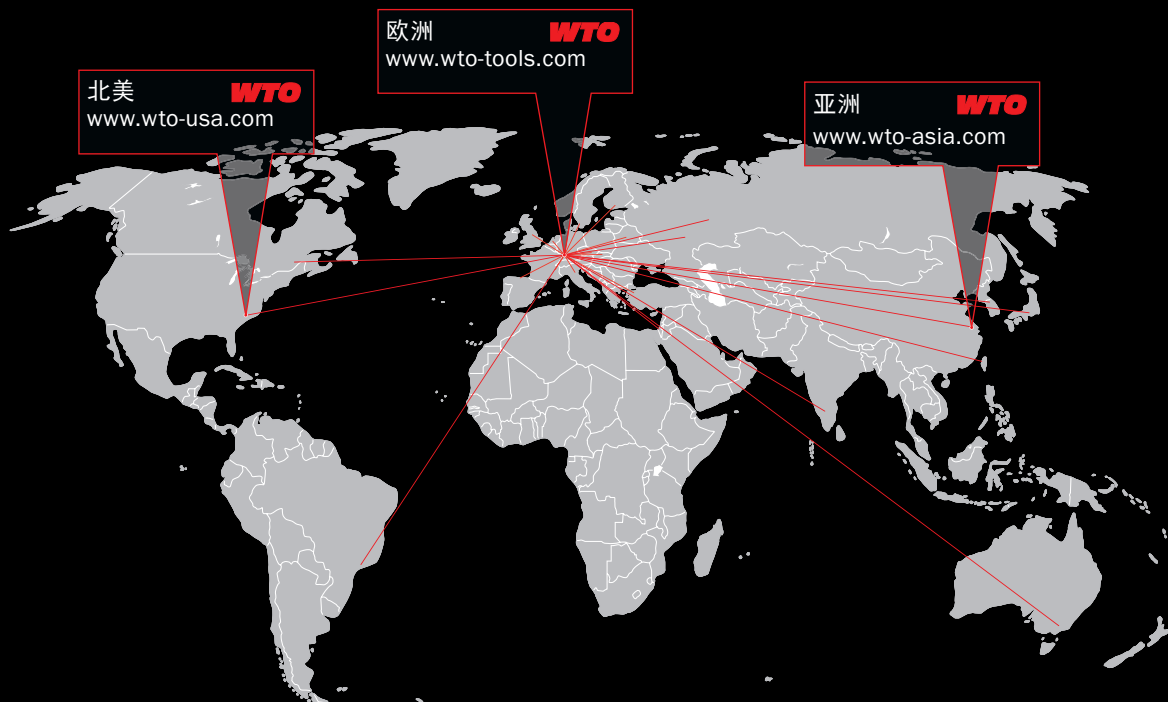

WTO Werkzeug-
Einrichtungen GmbH
有限公司
Neuer Hohdammweg 1
77797 Ohlsbach
德国

WTO Inc. 美国分公司
13900-F South Lakes Dr.
Charlotte, NC 28273
美国

WTO 亚洲
上海市松江区九亭镇
伴亭路228号2号楼
109-110 室
邮编: 201615 上海
中国

在您所在地的WTO得力的销售伙伴为您提供产品咨询服务

澳大利亚
Dimac Tooling Ltd.
sales@dimac.com.au

英国
Cutwel Ltd.
sales@cutwel.net

韩国
WTO Office Korea
is.chon@wto-korea.com

瑞士
Utilis AG
info@utilis.com

巴西
TF2
tfdois@tfdois.com.br

匈牙利
Prevotex Hungary Kft.
info@prevotex.hu

墨西哥
Workholding Engineering De México
info@wem.com.mx

斯洛伐克
ALBA precision s.r.o.
albabprecision@albabprecision.sk

中国
Shanghai Gangde
wtocando@yahoo.com

印度
Ulhas Patil
u.patil@wto-asia.com

荷兰
Toologic BeNeLux B.V.
info@toologic-benelux.nl

西班牙
ITALMATIC, S.A.
italmatic@italmatic.es

丹麦
AVN Teknik A/S
cjo@avn.dk

以色列
E.Y.A.R. Ltd.
boris@eyar.co.il

挪威
Helge Karlsen Verktøy og Maskin AS
hkvm@hkvm.no

台湾
Kaiko Co., Ltd.
info@kaiko.com.tw

芬兰
Suomen Terätuonti Oy
myynti@stt.as

意大利
Prymark srl
commerciale@prymark.it

波兰
ARCO Andrzej Rudenko
info@arcotools.pl

土耳其
MYK CNC MAKINA SAN. VE
huseyin.tatlidil@mykcnc.com.tr

法国, 东部
Alexandre Mathelin
alm@wto.de

日本
NK Works Co. Ltd.
k_samba@nk-works.co.jp

罗马尼亚
SC Elif Trading SRL
bulent.ozkan@eliftrading.com

捷克
ALBA precision, spol. s.r.o.
info@albabprecision.cz

法国, 西部
Christophe Archambault
car@wto.de

加拿大
Mittmann Industrial Inc.
info@mittmann.com

瑞典
Bonhron & Ewing AB
info@bonhron-ewing.se

乌克兰
„LLC“ SPA Stankopromimport
info@phoenix-ua.com

商标WTO、QuickFlex和nanoFlex属于WTO Vermögensverwaltung GmbH所有。
商标CoolSpeed属于WTO公司所有。