

# Tool Holder Program

Lynx 2100 M/MS/LY/LSY  
Lynx 300 M, 2600 Y, Puma GT2100, 2600 M  
Lynx 2600 SY (12ST)  
Puma 2100, 2600(II) M/MS/Y/SY (BMT55)  
Puma 2100, 2600(II) M/MS/Y/SY (BMT65)  
Puma 2100, 2600 Y/SY (16ST, BMT55)  
Puma 3100 M/Y/SY, GT3100 M  
Puma 4100, 5100 M/LM/LY  
Puma 600, 700, 800 M/LM/LY  
Puma DNT 2100-2600 (BMT55)  
Puma DNT 2100-2600 (BMT65)  
Puma MX1600 ST (BMT45)  
Puma MX1600, 2100 ST (BMT55)  
Puma MX2600 T/ST  
Puma SMX2100 ST  
Puma SMX2600, 3100 ST  
Puma TT1300 SY/SYY  
Puma TT1800, 2100 MS/SY/SYY  
Puma TT2500 MS/SY

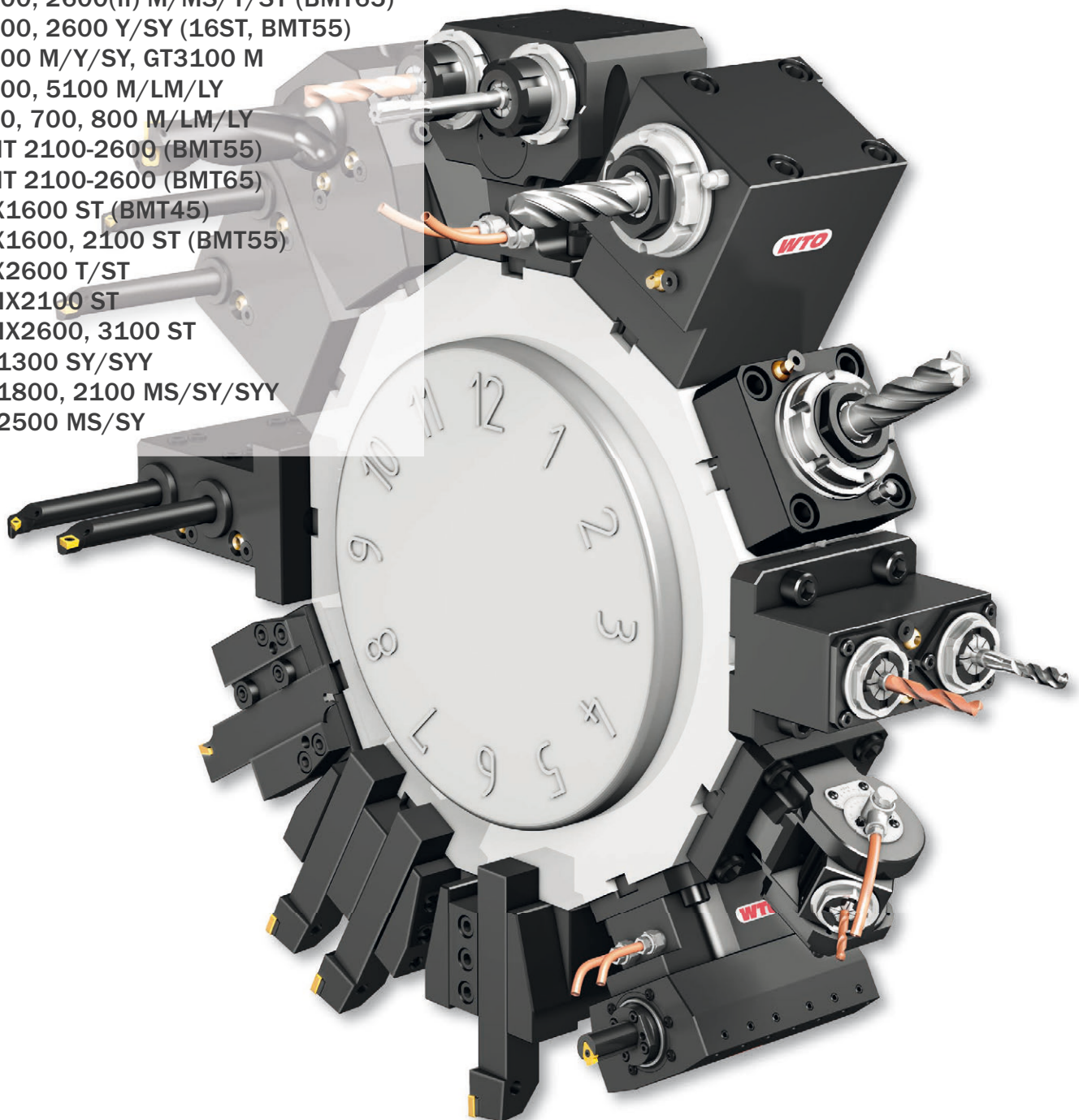

# QuickFlex®

The new quick change system for high performance and precision.

Minimal investment, maximal expandability.

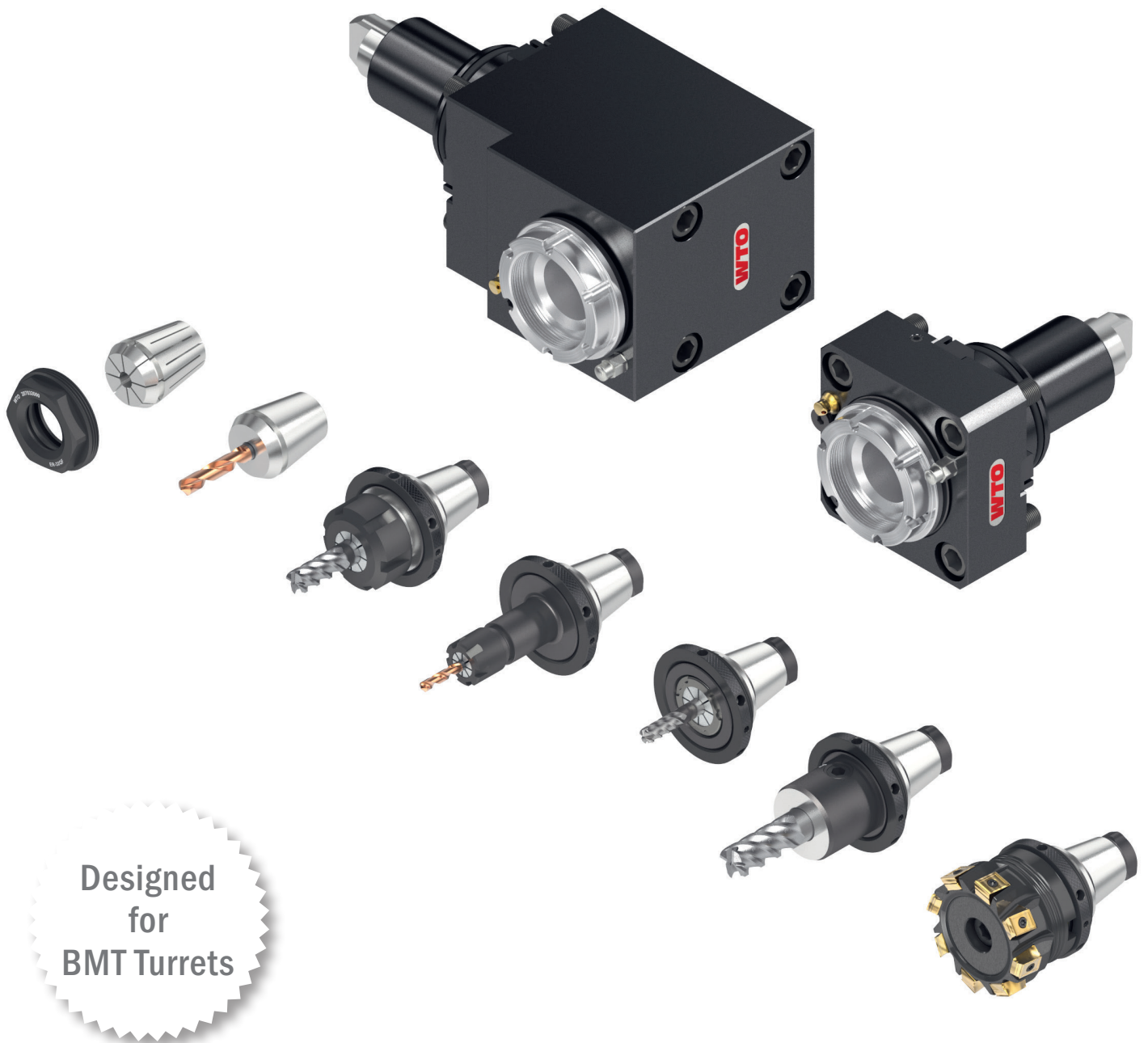

Designed  
for  
BMT Turrets

Lynx 2100 M/M/S/LY/LSY	Page	4 - 8
Lynx 300 M,2600 Y, Puma GT2100,2600 M	Page	9 - 11
Lynx 2600 SY (12ST)	Page	12 - 16
Puma 2100,2600(II) M/M/S/Y/SY (BMT55)	Page	17 - 22
Puma 2100,2600(II) M/M/S/Y/SY (BMT65)	Page	23 - 27
Puma 2100, 2600 Y/SY (16ST, BMT55)	Page	28 - 31
Puma 3100 M/Y/SY, GT3100 M	Page	32 - 36
Puma 4100, 5100 M/LM/LY	Page	37 - 39
Puma 600, 700, 800 M/LM/LY	Page	40 - 41
Puma DNT 2100-2600 (BMT55)	Page	42 - 44
Puma DNT 2100-2600 (BMT65)	Page	45 - 47
Puma MX1600 ST (BMT45)	Page	48 - 50
Puma MX1600, 2100 ST (BMT55)	Page	51 - 54
Puma MX2600 T/ST	Page	55 - 58
Puma SMX2100 ST	Page	59 - 62
Puma SMX2600, 3100 ST	Page	63 - 66
Puma TT1300 SY/SYY	Page	67 - 69
Puma TT1800, 2100 MS/SY/SYY	Page	70 - 74
Puma TT2500 MS/SY	Page	75 - 79
Reduction sleeves	Page	80 - 81
Collets	Page	82 - 85

**EC = External coolant supply**  
**HP-IC = High pressure internal coolant supply through cutting tool**  
**IC 80 bar = Internal and external coolant supply**  
 Max. coolant pressure = 80 bar  
**IC 30 bar = Internal and external coolant supply**  
 Max. coolant pressure = 30 bar  
 Only use filtered coolant fluid (max. particle size = 50 µm)  
 Do not run without coolant  
 Do not use for machining abrasive materials such as cast iron, etc.

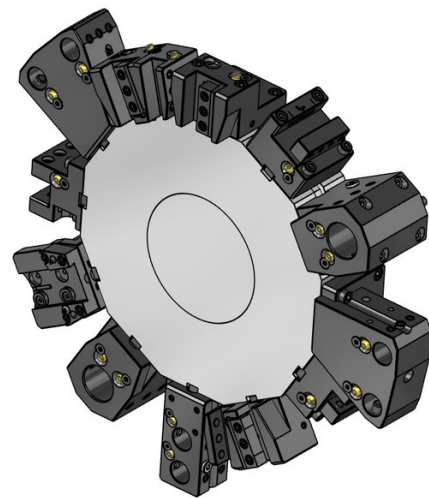
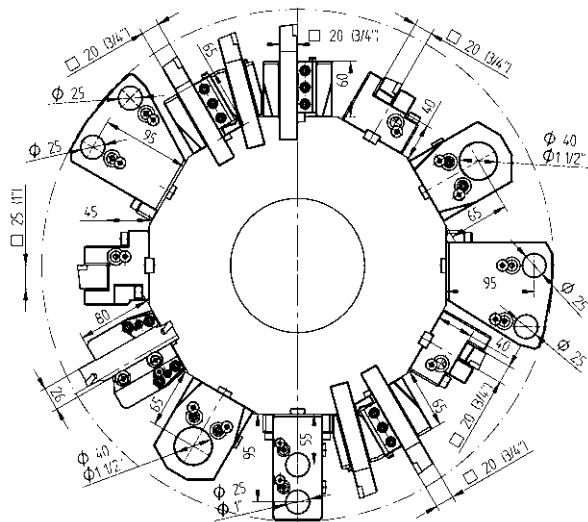

Static Toolholders - Standard Program

Static Toolholders - Standard Program



20  
3/4"

**OD cutting holder**

48-95083  
48-95084



20  
3/4"

**OD cutting holder, HP-IC**

48-100605-HP IC 80 bar  
48-108926-HP IC 80 bar



25  
1"

**OD cutting holder, HP-IC**

48-104395-HP IC 80 bar  
48-104396-HP IC 80 bar



20  
3/4"

**OD cutting holder, both sides**

48-95085  
48-95086



20  
3/4"

**OD cutting holder, both sides, HP-IC**

48-95085-HP IC 80 bar  
48-95086-HP IC 80 bar



20

**Face cutting holder**

48-109148



3/4"

**Face cutting holder**

48-95338



20  
3/4"

**Face cutting holder, HP-IC**

48-109148-HP IC 80 bar  
48-109149-HP IC 80 bar



25  
1"

**Face cutting holder, HP-IC**

48-104397-HP IC 80 bar  
48-104398-HP IC 80 bar



Ø 40  
Ø 1 1/2"

**Combination toolholder, LF=65**

48-95090 IC 80 bar  
48-95327 IC 80 bar



Ø 32

**Combination toolholder, universal, LF=85**

48-95998 IC 80 bar

 241132016 ER25

 241132020 ER32

Ø 1 1/4"

48-96029 IC 80 bar

 2411125020 ER32



Ø 25  
Ø 1"

**Boring bar holder, double, universal**

48-95093  
48-95325

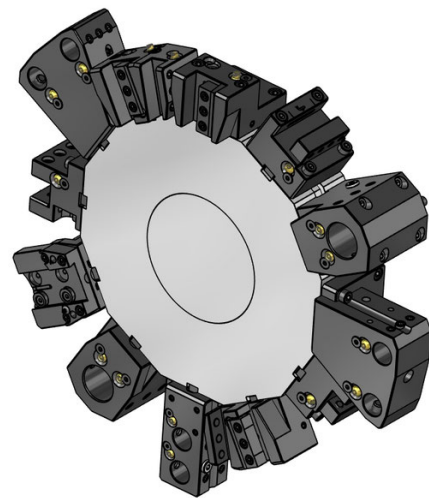
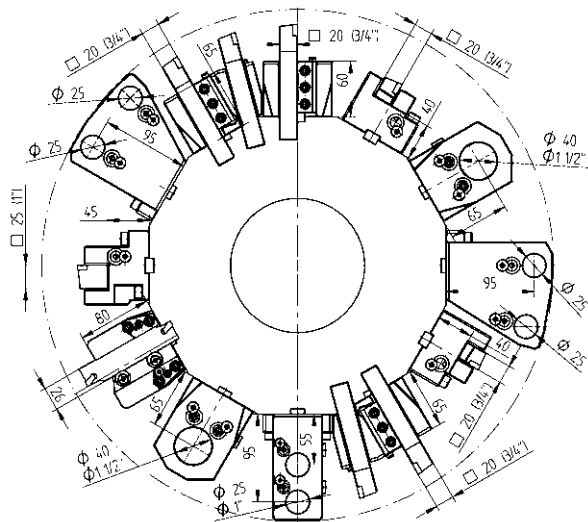

Static Toolholders - Enhanced Program



20

**OD cutting holder, double, 24 station**  
48-95088



20

**OD cutting holder, both sides, double, 24 station**  
48-95355



20 (3/4")

**OD cutting holder, both sides, double, Y axis**  
48-110811



SH 26

**Cut-off holder, adjustable**  
48-94968



SH 26  
SH 26

**Cut-off holder, adjustable, HP-IC**  
48-102252R IC 80 bar  
48-102252L IC 80 bar



Ø 25

**Boring bar holder, universal, double, 24 station**  
48-95092



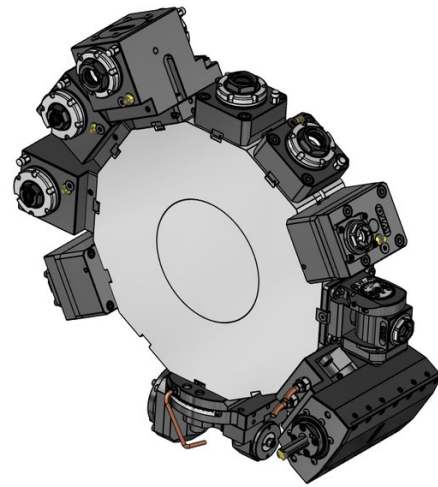
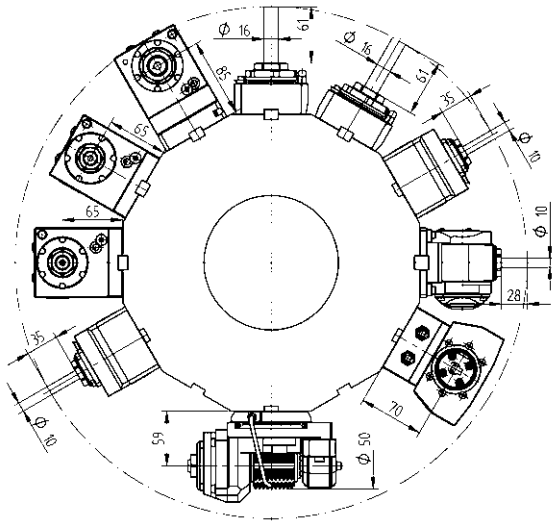

Driven Toolholders - QuickFlex®

Driven Toolholders - QuickFlex®



- Straight drill/milling unit**
- ER-25 QF 420125015-45 1:1 EC  
0067725000
  - ER-25 QF 420125016-45 1:1 IC 80 bar  
0067725000



- Right angle back set drill/milling unit, LF=85**
- ER-25 QF 420525024-45 1:1 EC  
0067725000
  - ER-25 QF 420525025-45 1:1 IC 80 bar  
0067725000



- Straight drill/milling unit (12000 RPM)**
- ER-25 QF 430125019-45 1:1 EC  
0067725000
  - ER-25 QF 430125020-45 1:1 IC 100 bar  
0067725000



- Right angle back set drill/milling unit, LF=85, (12000 RPM)**
- ER-25 QF 420525049-45 1:1 EC  
0067725000
  - ER-25 QF 420525050-45 1:1 IC 80 bar  
0067725000



- Right angle drill/milling unit, LF=65**
- ER-25 QF 420525015-45 1:1 EC  
0067725000
  - ER-25 QF 420525016-45 1:1 IC 80 bar  
0067725000



- Right angle drill/milling unit, both sides, LF=85**
- ER-25 QF 420525043-45 1:1 EC  
0067725000



- Right angle drill/milling unit (12000 RPM)**
- ER-25 QF 420525054-45 1:1 EC  
0067725000
  - ER-25 QF 420525055-45 1:1 IC 80 bar  
0067725000



- Right angle drill/milling unit, both sides, LF=85, (12000 RPM)**
- ER-25 QF 420525051-45 1:1 EC  
0067725000

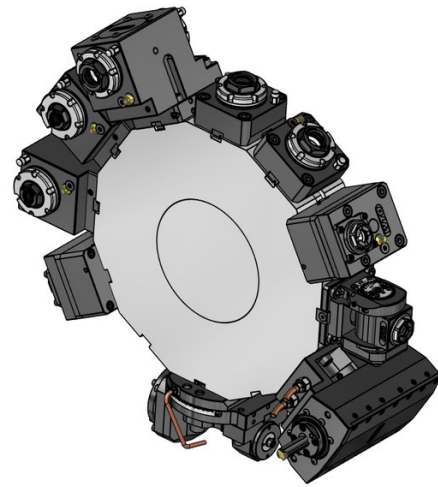
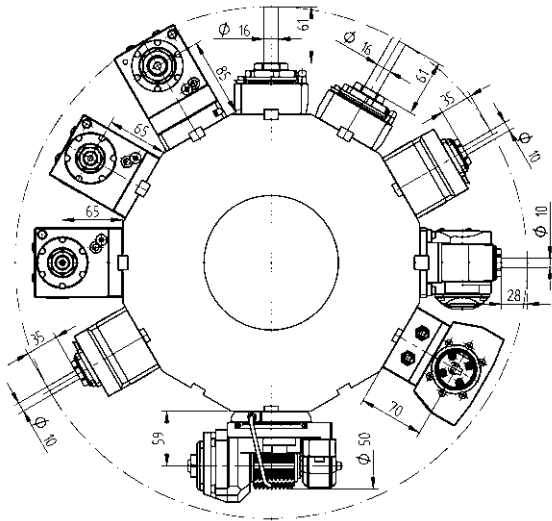

Driven Toolholders - Enhanced Program

Driven Toolholders - Enhanced Program



- Straight offset drill/milling unit**
- ER 16** 410410008-45 1:3 EC  
00675000937
  - ER 16** 410410002-45 1:3 IC 80 bar  
00675000937



- Right angle drill/milling unit, LF=65**
- ER-20 QF** 420520018-45 1:2 EC  
0067720001
  - ER-20 QF** 420520019-45 1:2 IC 80 bar  
0067720001
  - ER-25 QF** 420525020-45 2:1 EC  
0067725000
  - ER-25 QF** 420525021-45 2:1 IC 80 bar  
0067725000



- Adjustable angle drill/milling unit**
- ER 16** 411010008-45 1:1 EC  
00675000902
  - ER 16** 411010009-45 1:1 IC 80 bar  
00675000902
  - ER 11** 411007004-45 1:2 EC  
00675000914
  - ER 11** 411007005-45 1:2 IC 80 bar  
00675000914



- Gear hobbing unit**
- Type 15-2** 410900003-45 1:1 EC  
00675001015
- 160008152 Ø 8
  - 160010152 Ø 10
  - 160013152 Ø 13
  - 160016152 Ø 16
  - 160022152 Ø 22
  - 160015152 Ø 5/8"
  - 160019152 Ø 3/4"
  - 110587



- Straight drill/milling unit, double, Y axis**
- ER 20** 413002006-45 1:1 EC  
00675000947
  - ER 20** 413002008-45 1:1 IC 80 bar  
00675000947



- 2-spindle - Right angle drill/milling unit, Y axis**
- ER 20** 413502001-45 1:1 EC  
00675000939
  - ER 20** 413502002-45 1:1 IC 80 bar  
00675000939

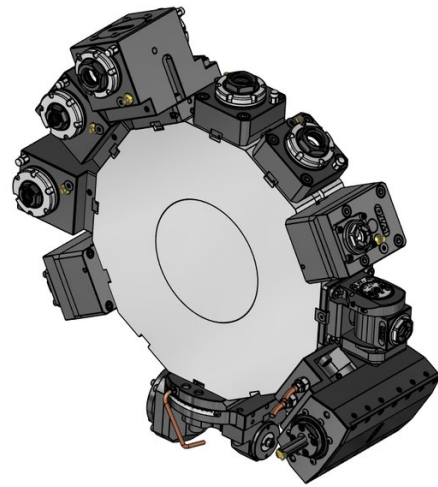
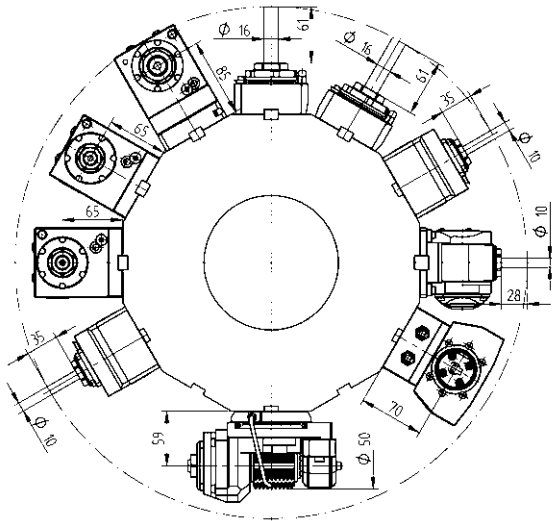

Driven Toolholders - Enhanced Program



**Broaching unit for ID and OD**

**Type 32**

414532005-45

1:1 EC



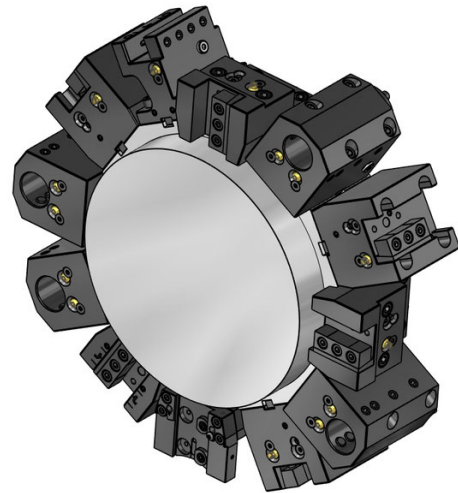
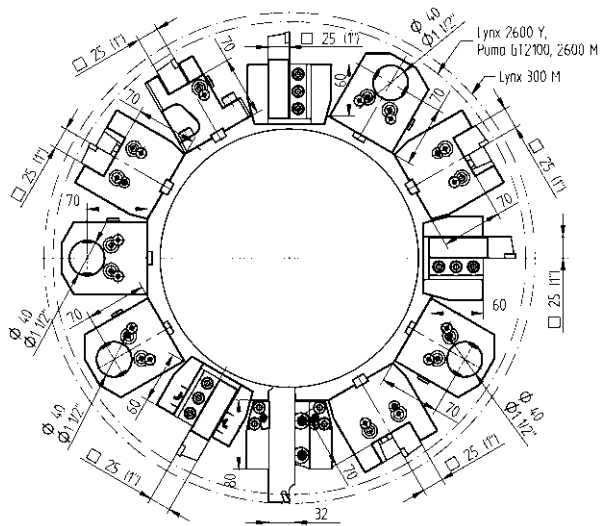

Static Toolholders - Standard Program

Static Toolholders - Enhanced Program



25  
1"

**OD cutting holder**

48-87097  
48-87098



25  
1"

**OD cutting holder, HP-IC**

48-87097-HP                      IC 80 bar  
48-87098-HP                      IC 80 bar



25  
1"

**Face cutting holder**

48-87101  
48-87102



25  
1"

**Face cutting holder, HP-IC**

48-87101-HP                      IC 80 bar  
48-87102-HP                      IC 80 bar



Ø 32  
Ø 40  
Ø 1 1/4"  
Ø 1 1/2"

**Combination toolholder, LF=70**

48-106897                      IC 80 bar  
48-87103                      IC 80 bar  
48-106872                      IC 80 bar  
48-87104                      IC 80 bar



48-87111

**Cover plate**



25(1")

**OD cutting holder, double, Y axis**

48-87140



SH 32

**Cut-off holder, adjustable**

48-103287



SH 32  
SH 32

**Cut-off holder, adjustable, HP-IC**

48-110160R                      IC 80 bar  
48-110160L                      IC 80 bar



Ø 25

**Boring bar holder, both sides, double, Y axis, short**

48-98353

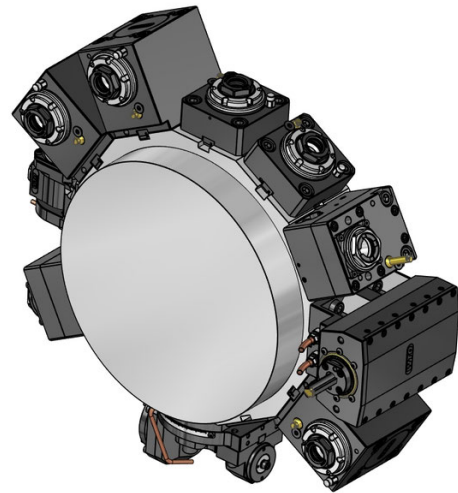
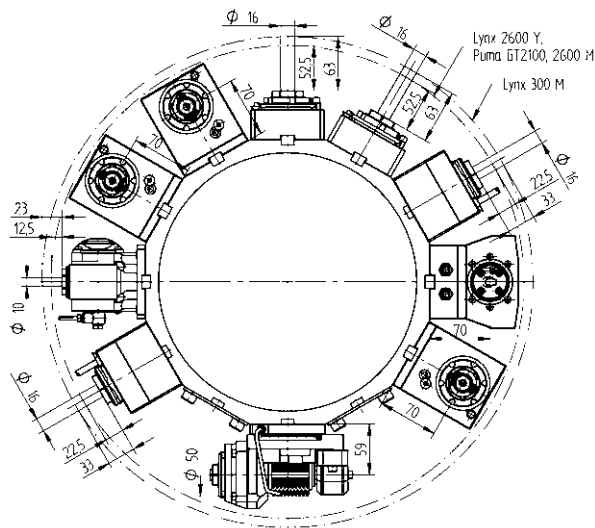

Driven Toolholders - QuickFlex®



**Straight drill/milling unit**

- |                 |              |     |           |
|-----------------|--------------|-----|-----------|
| <b>ER-25 QF</b> | 420125015-55 | 1:1 | EC        |
|                 | 0067725000   |     |           |
| <b>ER-25 QF</b> | 420125016-55 | 1:1 | IC 80 bar |
|                 | 0067725000   |     |           |



**Right angle drill/milling unit, LF=70**

- |                 |              |     |           |
|-----------------|--------------|-----|-----------|
| <b>ER-25 QF</b> | 420525015-55 | 1:1 | EC        |
|                 | 0067725000   |     |           |
| <b>ER-25 QF</b> | 420525016-55 | 1:1 | IC 80 bar |
|                 | 0067725000   |     |           |

Driven Toolholders - Enhanced Program



**Straight drill/milling unit**

- |              |              |     |           |
|--------------|--------------|-----|-----------|
| <b>ER 32</b> | 410120010-55 | 1:1 | EC        |
|              | 0067725000   |     |           |
| <b>ER 32</b> | 410120011-55 | 1:1 | IC 80 bar |
|              | 0067725000   |     |           |



**Straight milling unit with combination mill arbor DIN 6358**

- |               |              |     |    |
|---------------|--------------|-----|----|
| <b>Ø 22</b>   | 410222004-55 | 1:1 | EC |
|               | 00675000483  |     |    |
| <b>Ø 3/4"</b> | 410219002-55 | 1:1 | EC |
|               | 00675000483  |     |    |

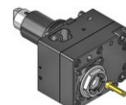

**Straight offset drill/milling unit**

- |              |              |     |           |
|--------------|--------------|-----|-----------|
| <b>ER 25</b> | 410116029-55 | 1:1 | EC        |
|              | 00675000932  |     |           |
| <b>ER 25</b> | 410116030-55 | 1:1 | IC 80 bar |
|              | 00675000932  |     |           |
| <b>ER 20</b> | 410113009-55 | 1:2 | EC        |
|              | 00675000939  |     |           |
| <b>ER 20</b> | 410113010-55 | 1:2 | IC 80 bar |
|              | 00675000939  |     |           |
| <b>ER 16</b> | 410410004-55 | 1:3 | EC        |
|              | 00675000937  |     |           |
| <b>ER 16</b> | 410410005-55 | 1:3 | IC 80 bar |
|              | 00675000937  |     |           |

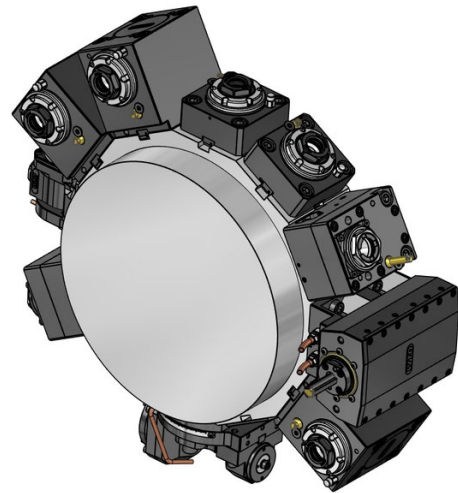
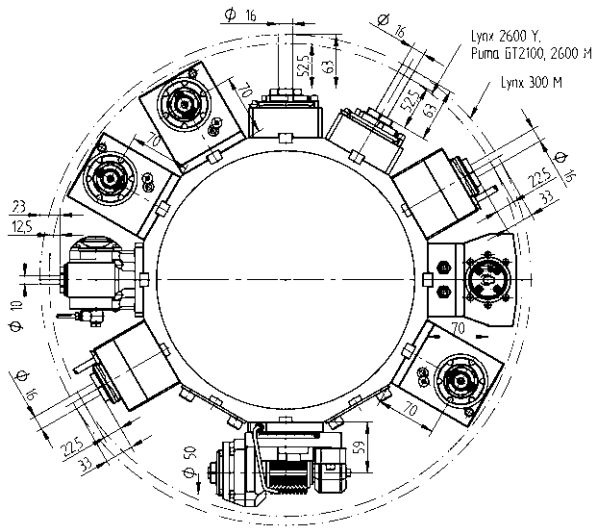

Driven Toolholders - Enhanced Program



**Right angle drill/milling unit, LF=70**

<b>ER 32</b>	410520033-55 0067725000	1:1	EC
<b>ER 32</b>	410520034-55 0067725000	1:1	IC 80 bar
<b>ER-20 QF</b>	420520012-55 0067720001	1:2	EC
<b>ER-20 QF</b>	420520013-55 0067720001	1:2	IC 80 bar
<b>ER 16</b>	410810016-55 00675000841	1:3	EC
<b>ER 16</b>	410810017-55 00675000841	1:3	IC 80 bar
<b>ER-25 QF</b>	420525030-55 0067725000	2:1	EC
<b>ER-25 QF</b>	420525031-55 0067725000	2:1	IC 80 bar



**Right angle milling unit with combination mill arbor DIN 6358, LF=70**

<b>Ø 22</b>	410622010-55 00675000483	1:1	EC
<b>Ø 3/4"</b>	410619005-55 00675000483	1:1	EC

Driven Toolholders - Enhanced Program



**Adjustable angle drill/milling unit**

<b>ER 16</b>	411010005-55 00675000902	1:1	EC
<b>ER 16</b>	411010006-55 00675000902	1:1	IC 80 bar
<b>ER 11</b>	411007007-55 00675000914	1:2	EC
<b>ER 11</b>	411007008-55 00675000914	1:2	IC 80 bar



**Gear hobbing unit**

<b>Type 15-2</b>	410900002-55 00675001015	1:1	EC
	160008152 Ø 8		
	160010152 Ø 10		
	160013152 Ø 13		
	160016152 Ø 16		
	160022152 Ø 22		
	160015152 Ø 5/8"		
	160019152 Ø 3/4"		
	110587		



**Broaching unit for ID and OD**

<b>Type 32</b>	414532001-55	1:1	EC
<b>Type 52</b>	414552000-55	1:1	EC

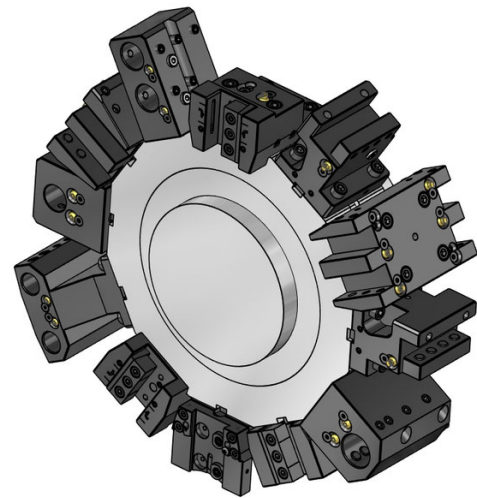
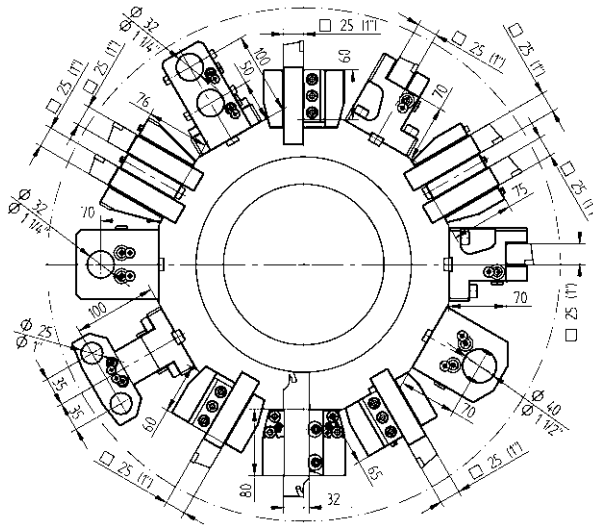

Static Toolholders - Standard Program

Static Toolholders - Standard Program



25  
1"

**OD cutting holder**

48-87097  
48-87098



25  
1"

**OD cutting holder, HP-IC**

48-87097-HP IC 80 bar  
48-87098-HP IC 80 bar



25  
1"

**OD cutting holder, both sides**

48-87099  
48-87100



25  
1"

**OD cutting holder, both sides, HP-IC**

48-87099-HP IC 80 bar  
48-87100-HP IC 80 bar



25  
1"

**Face cutting holder**

48-87101  
48-87102



25  
1"

**Face cutting holder, HP-IC**

48-87101-HP IC 80 bar  
48-87102-HP IC 80 bar



Ø 32  
Ø 40  
Ø 1 1/4"  
Ø 1 1/2"

**Combination toolholder, LF=70**

48-106897 IC 80 bar  
48-87103 IC 80 bar  
48-106872 IC 80 bar  
48-87104 IC 80 bar



Ø 32  
Ø 1 1/4"

**Boring bar holder, double**

48-87149  
48-87150



48-87111

**Cover plate**

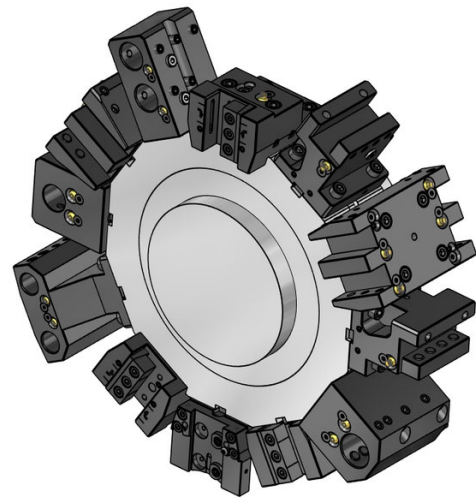
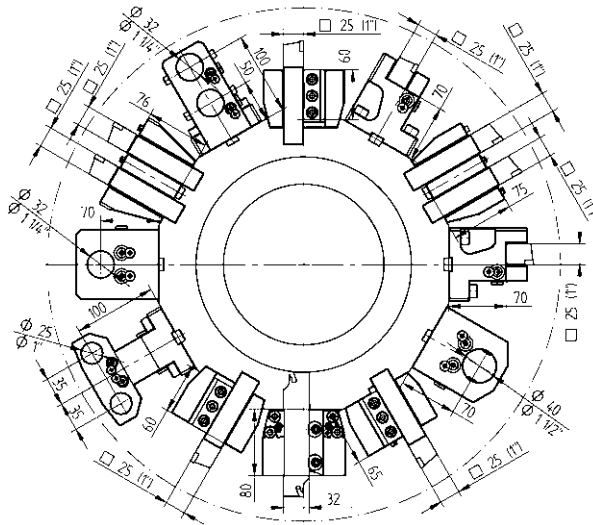

Static Toolholders - Enhanced Program



25(1")

**OD cutting holder, double, Y axis**

48-87140

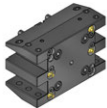

25(1")

**OD cutting holder, both sides, double, Y axis**

48-87141



SH 32

**Cut-off holder, adjustable**

48-103287



SH 32

**Cut-off holder, adjustable, HP-IC**

48-110160R

IC 80 bar

SH 32

48-110160L

IC 80 bar



Ø 25

**Boring bar holder, both sides, double, Y axis**

48-87147

Ø 1"

48-87148



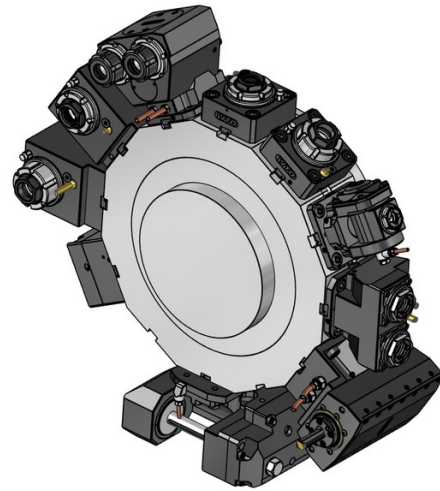
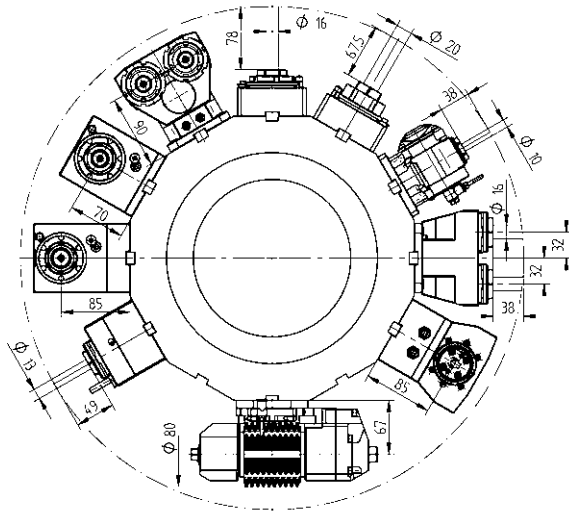

Driven Toolholders - QuickFlex®

- |                 |  |     |           |
|-----------------|--|-----|-----------|
|                 | <b>Straight drill/milling unit</b>                       |     |           |
| <b>ER-25 QF</b> | 420125015-55   | 1:1 | EC        |
|                 | 0067725000   |     |           |
| <b>ER-25 QF</b> | 420125016-55   | 1:1 | IC 80 bar |
|                 | 0067725000   |     |           |
|                 | <b>Right angle drill/milling unit, LF=70</b>             |     |           |
| <b>ER-25 QF</b> | 420525015-55   | 1:1 | EC        |
|                 | 0067725000   |     |           |
| <b>ER-25 QF</b> | 420525016-55   | 1:1 | IC 80 bar |
|                 | 0067725000   |     |           |
|                 | <b>Right angle drill/milling unit, LF=85</b>             |     |           |
| <b>ER-25 QF</b> | 420525018-55   | 1:1 | EC        |
|                 | 0067725000   |     |           |
| <b>ER-25 QF</b> | 420525019-55   | 1:1 | IC 80 bar |
|                 | 0067725000   |     |           |
|                 | <b>Right angle drill/milling unit, both sides, LF=85</b> |     |           |
| <b>ER-25 QF</b> | 420525020-55   | 1:1 | EC        |
|                 | 0067725000   |     |           |

Driven Toolholders - Enhanced Program

- |               |   |     |           |
|---------------|---|-----|-----------|
|               | <b>Straight drill/milling unit</b>                                |     |           |
| <b>ER 32</b>  | 410120010-55  | 1:1 | EC        |
|               | 0067725000  |     |           |
| <b>ER 32</b>  | 410120011-55  | 1:1 | IC 80 bar |
|               | 0067725000  |     |           |
|               | <b>Straight milling unit with combination mill arbor DIN 6358</b> |     |           |
| <b>Ø 22</b>   | 410222004-55  | 1:1 | EC        |
|               | 00675000483   |     |           |
| <b>Ø 3/4"</b> | 410219002-55  | 1:1 | EC        |
|               | 00675000483   |     |           |
|               | <b>Straight offset drill/milling unit</b>                         |     |           |
| <b>ER 25</b>  | 410116029-55  | 1:1 | EC        |
|               | 00675000932   |     |           |
| <b>ER 25</b>  | 410116030-55  | 1:1 | IC 80 bar |
|               | 00675000932   |     |           |
| <b>ER 20</b>  | 410113009-55  | 1:2 | EC        |
|               | 00675000939   |     |           |
| <b>ER 20</b>  | 410113010-55  | 1:2 | IC 80 bar |
|               | 00675000939   |     |           |
| <b>ER 16</b>  | 410410004-55  | 1:3 | EC        |
|               | 00675000937   |     |           |
| <b>ER 16</b>  | 410410005-55  | 1:3 | IC 80 bar |
|               | 00675000937   |     |           |

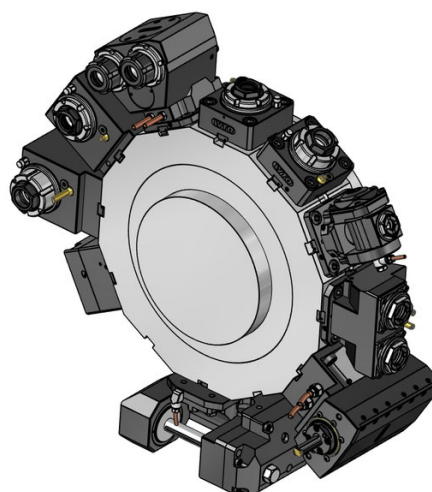
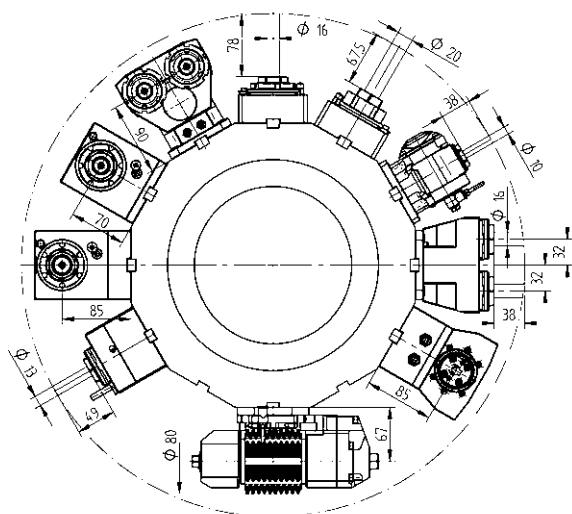

Driven Toolholders - Enhanced Program



**Right angle drill/milling unit, LF=70**

<b>ER 32</b>	410520033-55 0067725000	1:1	EC
<b>ER 32</b>	410520034-55 0067725000	1:1	IC 80 bar
<b>ER-20 QF</b>	420520012-55 0067720001	1:2	EC
<b>ER-20 QF</b>	420520013-55 0067720001	1:2	IC 80 bar
<b>ER 16</b>	410810016-55 00675000841	1:3	EC
<b>ER 16</b>	410810017-55 00675000841	1:3	IC 80 bar
<b>ER-25 QF</b>	420525030-55 0067725000	2:1	EC
<b>ER-25 QF</b>	420525031-55 0067725000	2:1	IC 80 bar

Driven Toolholders - Enhanced Program



**Right angle drill/milling unit, LF=85**

<b>ER 32</b>	410520030-55 0067725000	1:1	EC
<b>ER 32</b>	410520031-55 0067725000	1:1	IC 80 bar
<b>ER-20 QF</b>	420520014-55 0067720001	1:2	EC
<b>ER-20 QF</b>	420520015-55 0067720001	1:2	IC 80 bar
<b>ER 16</b>	410810020-55 00675000841	1:3	EC
<b>ER 16</b>	410810021-55 00675000841	1:3	IC 80 bar
<b>ER-25 QF</b>	420525032-55 0067725000	2:1	EC
<b>ER-25 QF</b>	420525033-55 0067725000	2:1	IC 80 bar



**Right angle milling unit with combination mill arbor DIN 6358, LF=70**

<b>Ø 22</b>	410622010-55 00675000483	1:1	EC
<b>Ø 3/4"</b>	410619005-55 00675000483	1:1	EC



**Right angle milling unit with combination mill arbor DIN 6358, LF=85**

<b>Ø 22</b>	410622011-55 00675000483	1:1	EC
<b>Ø 3/4"</b>	410619006-55 00675000483	1:1	EC

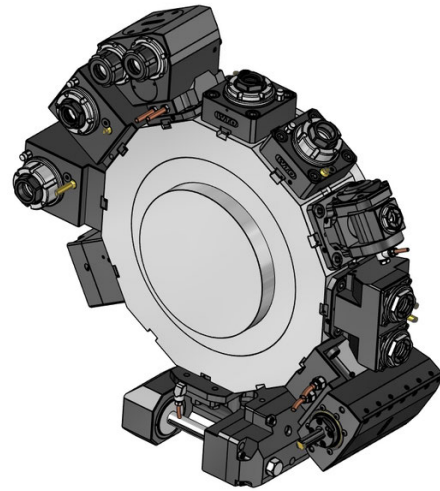
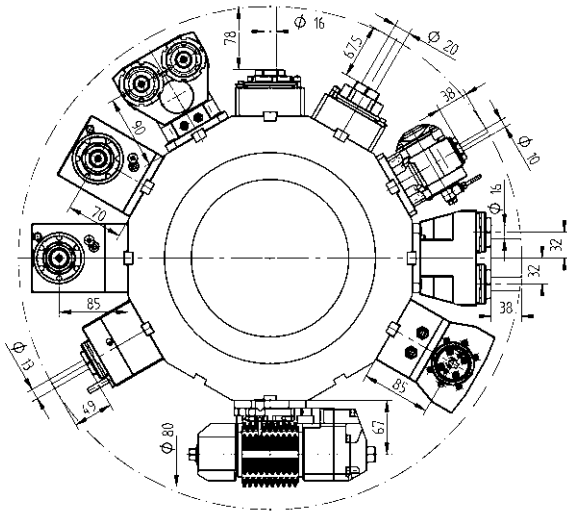

Driven Toolholders - Enhanced Program

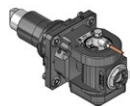

**Adjustable angle drill/milling unit**

<b>ER 16</b>	411010005-55 00675000902	1:1	EC
<b>ER 16</b>	411010006-55 00675000902	1:1	IC 80 bar
<b>ER 11</b>	411007007-55 00675000914	1:2	EC
<b>ER 11</b>	411007008-55 00675000914	1:2	IC 80 bar



**Gear hobbing unit**

<b>Type 16-1</b>	411500002-55	1:1	EC
<b>Type 16-1</b>	411500001-55 00675000927	2:1	EC
	160016161 Ø 16		
	160022161 Ø 22		
	160027161 Ø 27		
	160015161 Ø 5/8"		
	160019161 Ø 3/4"		
	160025161 Ø 1"		
	160031161 Ø 1 1/4"		
	110587		

Driven Toolholders - Enhanced Program



**Straight drill/milling unit, double, Y axis**

<b>ER 25</b>	413002004-55 00675000970	1:1	EC
<b>ER 25</b>	413002003-55 00675000970	1:1	IC 80 bar

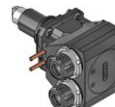

**2-spindle - Right angle drill/milling unit, Y axis**

<b>ER 25</b>	413502007-55 00675000915	1:1	EC
<b>ER 25</b>	413502008-55 00675000915	1:1	IC 80 bar

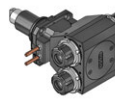

**2-spindle - Right angle drill/milling unit, both sides, Y axis**

<b>ER 25</b>	413502006-55 00675000915	1:1	EC
--------------	-----------------------------	-----	----

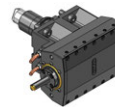

**Broaching unit for ID and OD**

<b>Type 32</b>	414532000-55	1:1	EC
----------------	--------------	-----	----

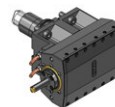

**Broaching unit for ID and OD**

<b>Type 52</b>	414552002-55	1:1	EC
----------------	--------------	-----	----

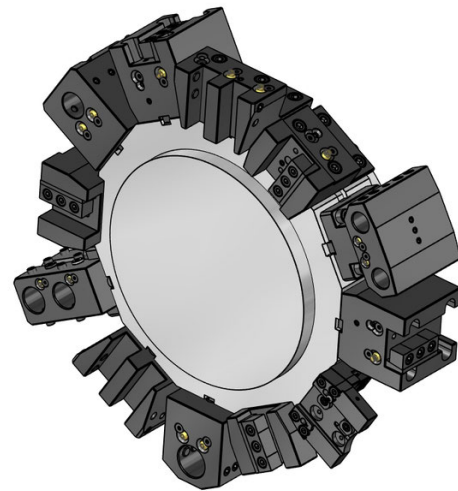
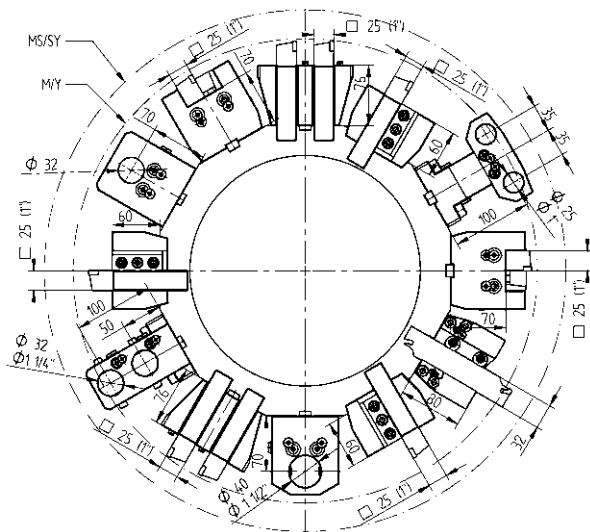

Static Toolholders - Standard Program (12ST)

Static Toolholders - Standard Program (12ST)



**OD cutting holder**  
 25 48-87097  
 1" 48-87098



**OD cutting holder, HP-IC**  
 25 48-87097-HP IC 80 bar  
 1" 48-87098-HP IC 80 bar



**OD cutting holder, both sides**  
 25 48-87099  
 1" 48-87100



**OD cutting holder, both sides, HP-IC**  
 25 48-87099-HP IC 80 bar  
 1" 48-87100-HP IC 80 bar



**Face cutting holder**  
 25 48-87101  
 1" 48-87102



**Face cutting holder, HP-IC**  
 25 48-87101-HP IC 80 bar  
 1" 48-87102-HP IC 80 bar



**Combination toolholder, LF=70**  
 Ø 32 48-106897 IC 80 bar  
 Ø 40 48-87103 IC 80 bar  
 Ø 1 1/4" 48-106872 IC 80 bar  
 Ø 1 1/2" 48-87104 IC 80 bar

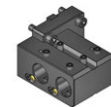

**Boring bar holder, double**  
 Ø 32 48-87149  
 Ø 1 1/4" 48-87150



**Cover plate**  
 48-87111

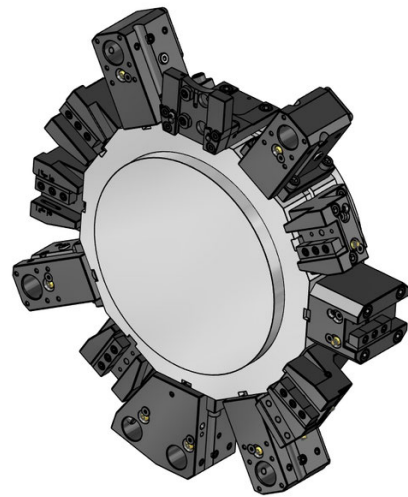
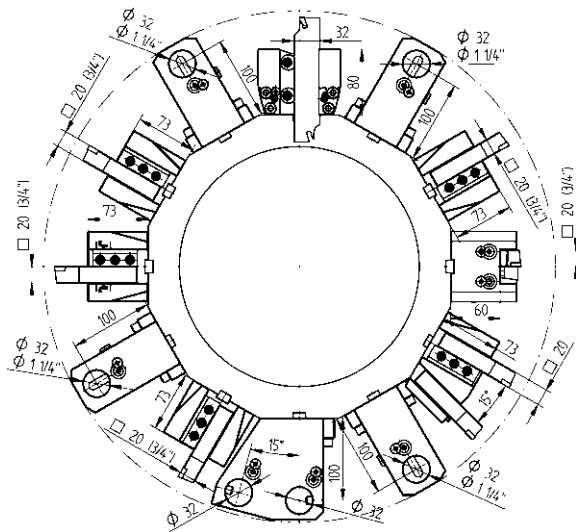

Static Toolholders - Standard Program (24ST)

Static Toolholders - Standard Program (24ST)



**OD cutting holder**  
 20 48-92036  
 3/4" 48-92037



**OD cutting holder, HP-IC**  
 20 48-92036-HP IC 80 bar  
 3/4" 48-92037-HP IC 80 bar



**OD cutting holder, both sides**  
 20 48-92038  
 3/4" 48-92039



**OD cutting holder, both sides, HP-IC**  
 20 48-92038-HP IC 80 bar  
 3/4" 48-92039-HP IC 80 bar



**Face cutting holder**  
 20 48-92045  
 3/4" 48-92046



**Face cutting holder, HP-IC**  
 20 48-92045-HP IC 80 bar  
 3/4" 48-92046-HP IC 80 bar



**Combination toolholder, universal, LF=100**

Ø 32 48-92043 IC 80 bar



241132016 ER25

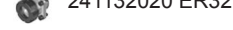

241132020 ER32

Ø 1 1/4" 48-92044 IC 80 bar



2411125020 ER32



**Boring bar holder, double**

Ø 32 48-87149

Ø 1 1/4" 48-87150



**Cover plate**

48-87111



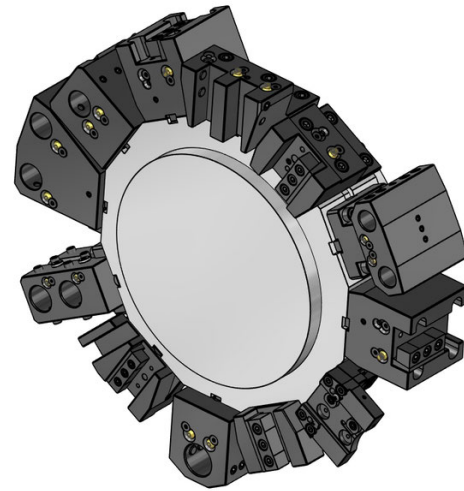
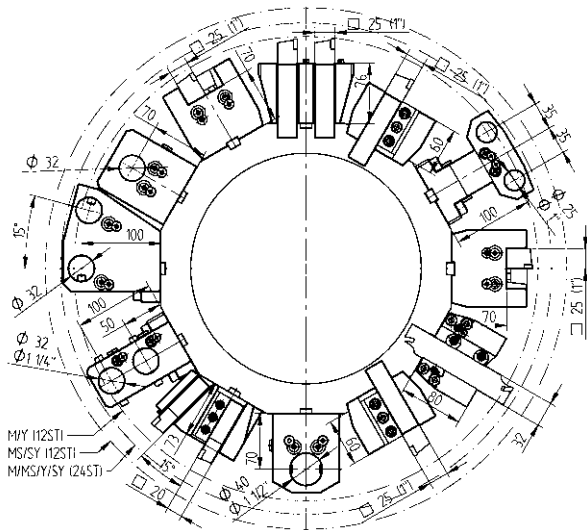

Static Toolholders - Enhanced Program

Static Toolholders - Enhanced Program



20

**OD cutting holder, double, 24 station**  
48-92069 EC



Ø 32

**Boring bar holder, double, 24 station**  
48-92073



20

**OD cutting holder, both sides, double, 24 station**  
48-92071



25(1")

**OD cutting holder, double, Y axis**  
48-87140

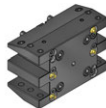

25(1")

**OD cutting holder, both sides, double, Y axis**  
48-87141



SH 32

**Cut-off holder, adjustable**  
48-103287



SH 32  
SH 32

**Cut-off holder, adjustable, HP-IC**  
48-110160R IC 80 bar  
48-110160L IC 80 bar



Ø 25  
Ø 1"

**Boring bar holder, both sides, double, Y axis**  
48-87147  
48-87148

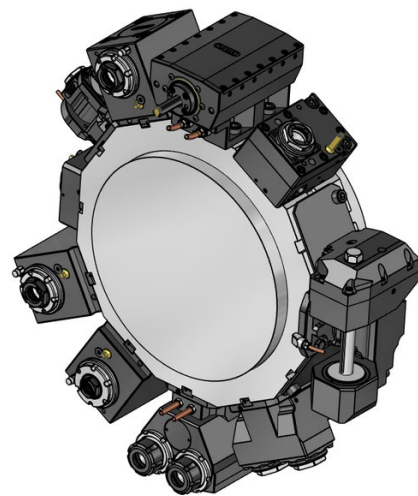
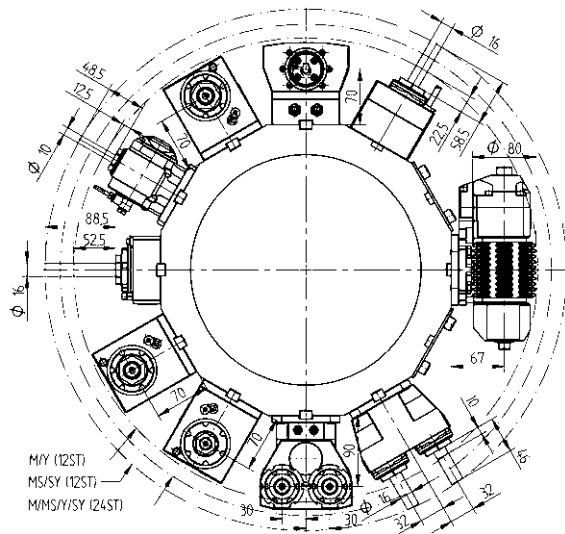

Driven Toolholders - QuickFlex®



- Straight drill/milling unit**
- |                 |              |     |           |
|-----------------|--------------|-----|-----------|
| <b>ER-25 QF</b> | 420125015-55 | 1:1 | EC        |
|                 | 0067725000   |     |           |
| <b>ER-25 QF</b> | 420125016-55 | 1:1 | IC 80 bar |
|                 | 0067725000   |     |           |



- Right angle drill/milling unit, LF=70**
- |                 |              |     |           |
|-----------------|--------------|-----|-----------|
| <b>ER-25 QF</b> | 420525015-55 | 1:1 | EC        |
|                 | 0067725000   |     |           |
| <b>ER-25 QF</b> | 420525016-55 | 1:1 | IC 80 bar |
|                 | 0067725000   |     |           |



- Right angle drill/milling unit, both sides, LF=70**
- |                 |              |     |    |
|-----------------|--------------|-----|----|
| <b>ER-25 QF</b> | 420525017-55 | 1:1 | EC |
|                 | 0067725000   |     |    |

Driven Toolholders - Enhanced Program



- Straight drill/milling unit**
- |              |              |     |           |
|--------------|--------------|-----|-----------|
| <b>ER 32</b> | 410120010-55 | 1:1 | EC        |
|              | 0067725000   |     |           |
| <b>ER 32</b> | 410120011-55 | 1:1 | IC 80 bar |
|              | 0067725000   |     |           |



- Straight milling unit with combination mill arbor DIN 6358**
- |               |              |     |    |
|---------------|--------------|-----|----|
| <b>Ø 22</b>   | 410222004-55 | 1:1 | EC |
|               | 00675000483  |     |    |
| <b>Ø 3/4"</b> | 410219002-55 | 1:1 | EC |
|               | 00675000483  |     |    |



- Straight offset drill/milling unit**
- |              |              |     |           |
|--------------|--------------|-----|-----------|
| <b>ER 25</b> | 410116029-55 | 1:1 | EC        |
|              | 00675000932  |     |           |
| <b>ER 25</b> | 410116030-55 | 1:1 | IC 80 bar |
|              | 00675000932  |     |           |
| <b>ER 20</b> | 410113009-55 | 1:2 | EC        |
|              | 00675000939  |     |           |
| <b>ER 20</b> | 410113010-55 | 1:2 | IC 80 bar |
|              | 00675000939  |     |           |
| <b>ER 16</b> | 410410004-55 | 1:3 | EC        |
|              | 00675000937  |     |           |
| <b>ER 16</b> | 410410005-55 | 1:3 | IC 80 bar |
|              | 00675000937  |     |           |

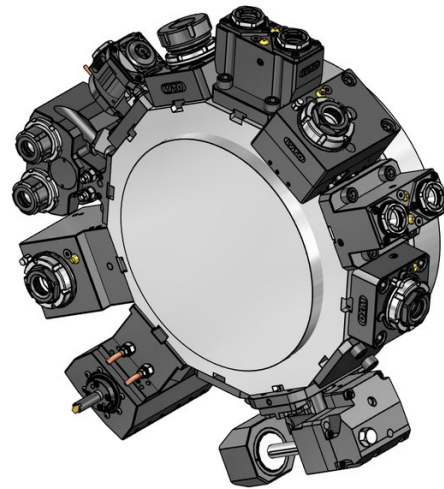
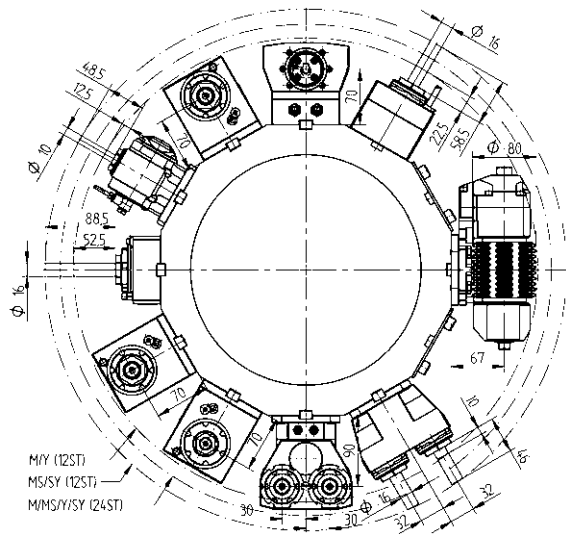

Driven Toolholders - Enhanced Program



**Right angle drill/milling unit, LF=70**

<b>ER 32</b>	410520033-55 0067725000	1:1	EC
<b>ER 32</b>	410520034-55 0067725000	1:1	IC 80 bar
<b>ER-20 QF</b>	420520012-55 0067720001	1:2	EC
<b>ER-20 QF</b>	420520013-55 0067720001	1:2	IC 80 bar
<b>ER 16</b>	410810016-55 00675000841	1:3	EC
<b>ER 16</b>	410810017-55 00675000841	1:3	IC 80 bar
<b>ER-25 QF</b>	420525030-55 0067725000	2:1	EC
<b>ER-25 QF</b>	420525031-55 0067725000	2:1	IC 80 bar



**Right angle milling unit with combination mill arbor DIN 6358, LF=70**

<b>Ø 22</b>	410622010-55 00675000483	1:1	EC
<b>Ø 3/4"</b>	410619005-55 00675000483	1:1	EC



**Right angle back set drill/milling unit**

<b>ER 25</b>	410516024-55 00675000801	1:1	EC
<b>ER 25</b>	410516025-55 00675000801	1:1	IC 80 bar

Driven Toolholders - Enhanced Program



**Adjustable angle drill/milling unit**

<b>ER 16</b>	411010005-55 00675000902	1:1	EC
<b>ER 16</b>	411010006-55 00675000902	1:1	IC 80 bar
<b>ER 11</b>	411007007-55 00675000914	1:2	EC
<b>ER 11</b>	411007008-55 00675000914	1:2	IC 80 bar



**Gear hobbing unit**

<b>Type 16-1</b>	411500002-55	1:1	EC
<b>Type 16-1</b>	411500001-55 00675000927	2:1	EC
	160016161 Ø 16		
	160022161 Ø 22		
	160027161 Ø 27		
	160015161 Ø 5/8"		
	160019161 Ø 3/4"		
	160025161 Ø 1"		
	160031161 Ø 1 1/4"		
	110587		

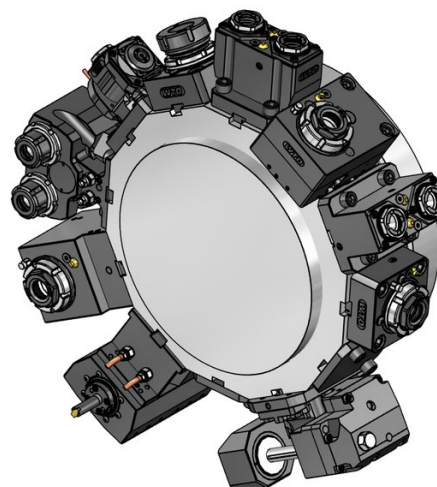
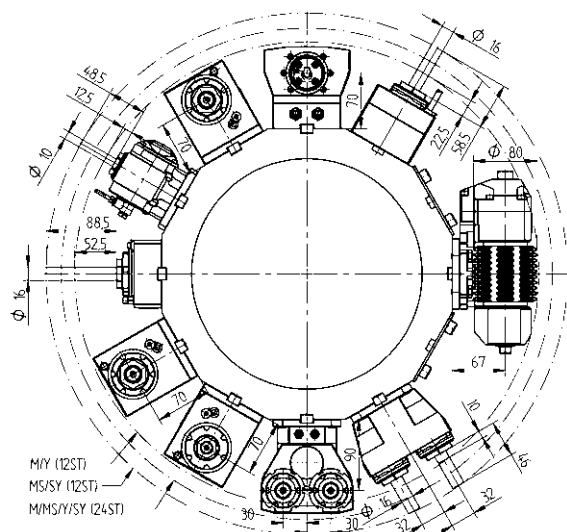

Driven Toolholders - Enhanced Program



**Straight drill/milling unit, double, Y axis**

- ER 25    413002004-55                      1:1    EC  
✂ 00675000970
- ER 25    413002003-55                      1:1    IC 80 bar  
✂ 00675000970

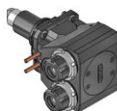

**2-spindle - Right angle drill/milling unit, Y axis**

- ER 25    413502007-55                      1:1    EC  
✂ 00675000915
- ER 25    413502008-55                      1:1    IC 80 bar  
✂ 00675000915



**2-spindle - Right angle drill/milling unit, both sides, Y axis**

- ER 25    413502006-55                      1:1    EC  
✂ 00675000915



**Broaching unit for ID and OD**

- Type 32    414532001-55                      1:1    EC
- Type 52    414552000-55                      1:1    EC

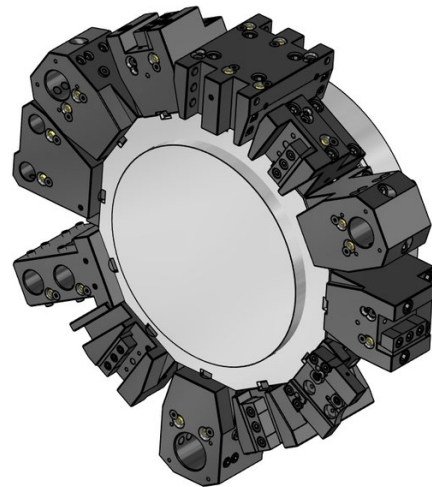
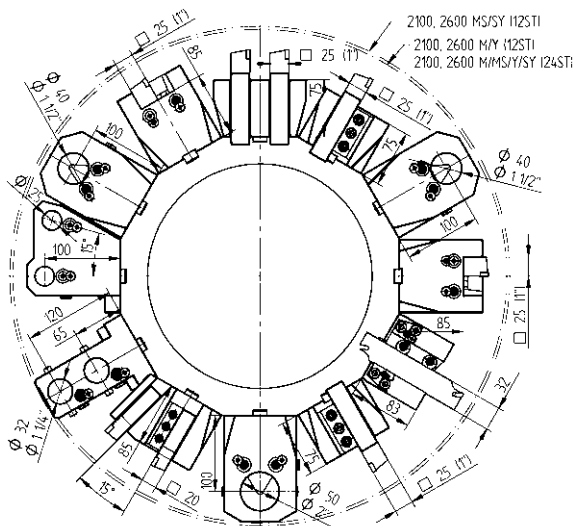

Static Toolholders - Standard Program

Static Toolholders - Standard Program



25  
1"

**OD cutting holder**

48-92428  
48-92466



25  
1"

**OD cutting holder, HP-IC**

48-92428-HP IC 80 bar  
48-92466-HP IC 80 bar



25  
1"

**OD cutting holder, both sides**

48-92438  
48-92472



25  
1"

**OD cutting holder, both sides, HP-IC**

48-92438-HP IC 80 bar  
48-92472-HP IC 80 bar



25  
1"

**Face cutting holder, long**

48-92958  
48-92959



Ø 40

**Combination toolholder, LF=100**

48-92397 IC 80 bar

241140020 ER32

241140026 ER40

Ø 50

48-92467 IC 80 bar

Ø 1 1/2"

48-92468 IC 80 bar

2411150020 ER32

Ø 2"

48-92469 IC 80 bar

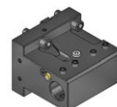

Ø 32

**Boring bar holder, both sides**

48-101033

Ø 1 1/4"

48-113514



Ø 32

**Boring bar holder, double**

48-84524

Ø 1 1/4"

48-86905



48-87089

**Cover plate**



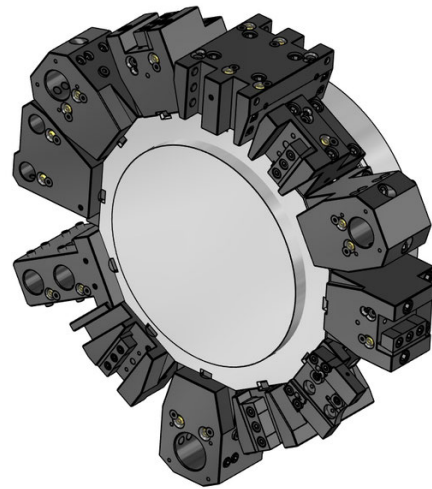
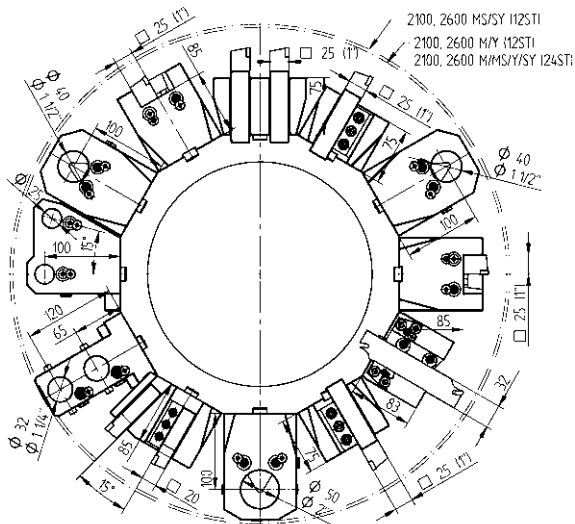

Static Toolholders - Enhanced Program

Static Toolholders - Enhanced Program



25  
1"

**OD cutting holder, short**

48-86991  
48-86992



25  
1"

**OD cutting holder, short, HP-IC**

48-86991-HP IC 80 bar  
48-86992-HP IC 80 bar



25  
1"

**OD cutting holder, long**

48-86711  
48-86712



25  
1"

**OD cutting holder, both sides, long**

48-84523  
48-86718



20

**OD cutting holder, double, 24 station**

48-92089



20

**OD cutting holder, both sides, double, 24 station**

48-92091



25(1")

**OD cutting holder, double, Y axis**

48-86103



25(1")

**OD cutting holder, both sides, double, Y axis**

48-86150



SH 32

**Cut-off holder, adjustable**

48-99060



SH 32  
SH 32

**Cut-off holder, adjustable, HP-IC**

48-102256R IC 80 bar  
48-102256L IC 80 bar



Ø 25

**Boring bar holder, double, 24 station**

48-92102



Ø 25  
Ø 1"

**Combination toolholder, both sides, double, 24 station**

48-109092  
48-108887



Ø 50

**Boring bar holder, with slot, LF=100**

48-119005

EC



Ø 32  
Ø 1 1/4"

**Boring bar holder, double, both sides**

48-86160  
48-86274

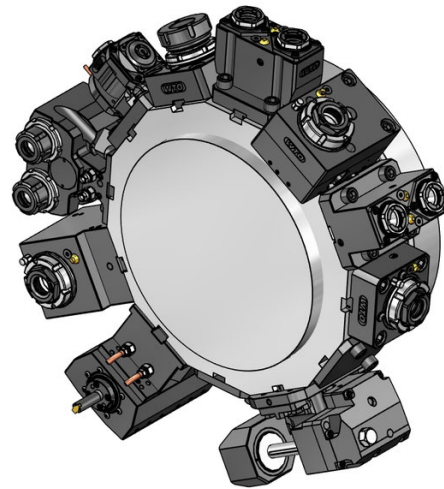
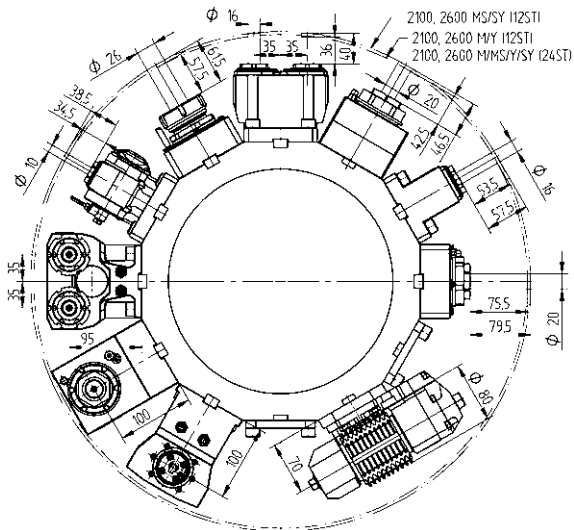

Driven Toolholders - QuickFlex®



**Straight drill/milling unit**

- |                 |                                      |     |            |
|-----------------|--------------------------------------|-----|------------|
| <b>ER-32 QF</b> | QF32-DNE-BT65A-058-E-A<br>0067732000 | 1:1 | EC         |
| <b>ER-32 QF</b> | QF32-DNE-BT65A-060-I-A<br>0067732000 | 1:1 | IC 100 bar |



**Straight drill/milling unit - QF smart (EU, US, CA, JP)**

- |                 |   |     |            |
|-----------------|---|-----|------------|
| <b>ER-32 QF</b> | QF32-DNE-BT65A-060-I-SB-A<br>0067732000 | 1:1 | IC 100 bar |
|                 | LI-F12-01                               |     |            |



**Right angle drill/milling unit, LF=100**

- |                 |                                      |     |            |
|-----------------|--------------------------------------|-----|------------|
| <b>ER-32 QF</b> | 420532018-65<br>0067732000           | 1:1 | EC         |
| <b>ER-32 QF</b> | QF32-DNI-BT65A-100-I-A<br>0067732000 | 1:1 | IC 100 bar |



**Right angle drill/milling unit - QF smart (EU, US, CA, JP), LF=100**

- |                 |   |     |            |
|-----------------|---|-----|------------|
| <b>ER-32 QF</b> | QF32-DNI-BT65A-100-I-SB-A<br>0067732000 | 1:1 | IC 100 bar |
|                 | LI-F12-01                               |     |            |



**Right angle drill/milling unit, both sides, LF=100**

- |                 |                            |     |    |
|-----------------|----------------------------|-----|----|
| <b>ER-32 QF</b> | 420532020-65<br>0067732000 | 1:1 | EC |
|-----------------|----------------------------|-----|----|

Driven Toolholders - Enhanced Program



**Straight drill/milling unit**

- |              |                                       |     |            |
|--------------|---------------------------------------|-----|------------|
| <b>ER 40</b> | ER40-DNE-BT65A-084-E-A<br>00675000079 | 1:1 | EC         |
| <b>ER 40</b> | ER40-DNE-BT65A-086-I-A<br>00675000079 | 1:1 | IC 100 bar |



**Straight offset drill/milling unit**

- |                 |                            |     |           |
|-----------------|----------------------------|-----|-----------|
| <b>ER-32 QF</b> | 420132037-65<br>0067732000 | 1:1 | EC        |
| <b>ER-32 QF</b> | 420132038-65<br>0067732000 | 1:1 | IC 80 bar |
| <b>ER-25 QF</b> | 420125010-65<br>0067725001 | 1:2 | EC        |
| <b>ER-25 QF</b> | 420125011-65<br>0067725001 | 1:2 | IC 80 bar |



**Right angle drill/milling unit, LF=100**

- |              |                             |     |           |
|--------------|-----------------------------|-----|-----------|
| <b>ER 40</b> | 410526007-65<br>00675000079 | 1:1 | EC        |
| <b>ER 40</b> | 410526008-65<br>00675000079 | 1:1 | IC 80 bar |

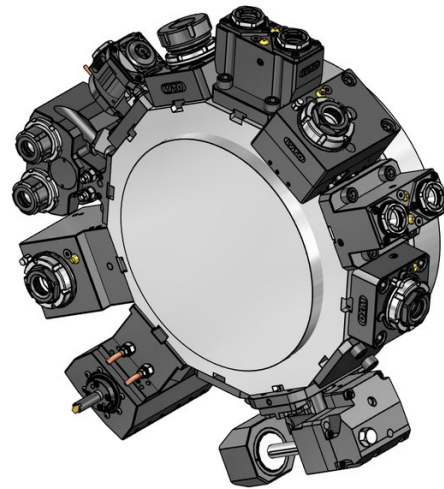
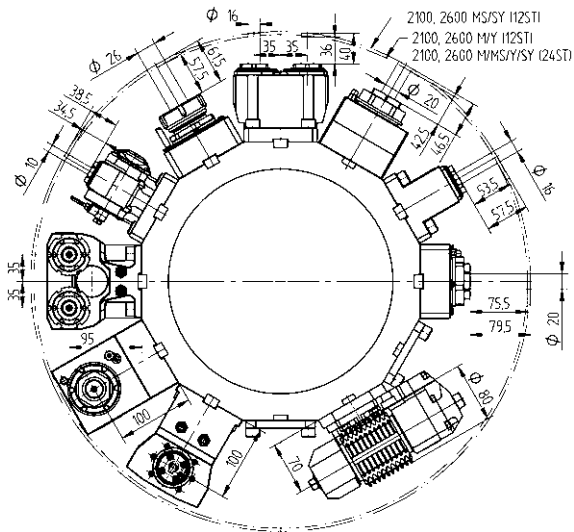

Driven Toolholders - Enhanced Program

Driven Toolholders - Enhanced Program



<b>Right angle drill/milling unit, LF=100</b>			
<b>ER-25 QF</b>	QF25-DNI-BT65A-100-E-S-A	1:2	EC
	0067725001		
<b>ER-25 QF</b>	QF25-DNI-BT65A-100-I-S-A	1:2	IC 100 bar
	0067725001		
<b>ER-32 QF</b>	QF32-DNI-BT65A-100-E-T-A	2:1	EC
	0067732000		
<b>ER-32 QF</b>	QF32-DNI-BT65A-100-I-T-A	2:1	IC 100 bar
	0067732000		



<b>Right angle back set drill/milling unit</b>			
<b>ER-32 QF</b>	420532090-65	1:1	EC
	0067732000		
<b>ER-32 QF</b>	420532091-65	1:1	IC 80 bar
	0067732000		



<b>Adjustable angle drill/milling unit</b>			
<b>ER 16</b>	411010002-65	1:1	EC
	00675000902		
<b>ER 16</b>	411010003-65	1:1	IC 80 bar
	00675000902		
<b>ER 11</b>	411007002-65	1:2	EC
	00675000914		
<b>ER 11</b>	411007003-65	1:2	IC 80 bar
	00675000914		



<b>Gear hobbing unit</b>			
<b>Type 16-1</b>	411500003-65	1:1	EC
<b>Type 16-1</b>	411500002-65	2:1	EC
	00675000927		
	160016161 Ø 16		
	160022161 Ø 22		
	160027161 Ø 27		
	160015161 Ø 5/8"		
	160019161 Ø 3/4"		
	160025161 Ø 1"		
	160031161 Ø 1 1/4"		
	110587		



<b>Straight drill/milling unit, both sides</b>			
<b>ER 25</b>	413002005-65	1:1	EC
	00675000907		



<b>Straight drill/milling unit, double, Y axis</b>			
<b>ER 25</b>	413002004-65	1:1	EC
	00675000907		

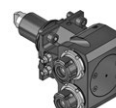

<b>2-spindle - Right angle drill/milling unit, Y axis</b>			
<b>ER 25</b>	413502006-65	1:1	EC
	00675000915		
<b>ER 25</b>	413502007-65	1:1	IC 80 bar
	00675000915		

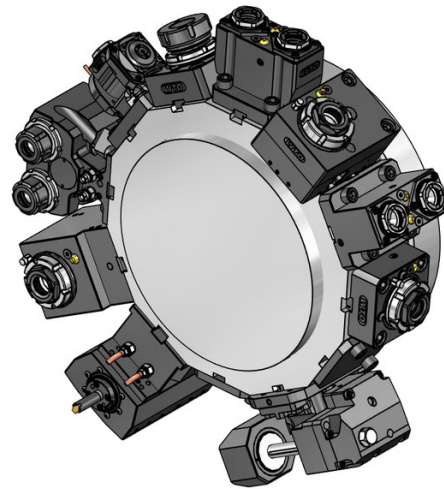
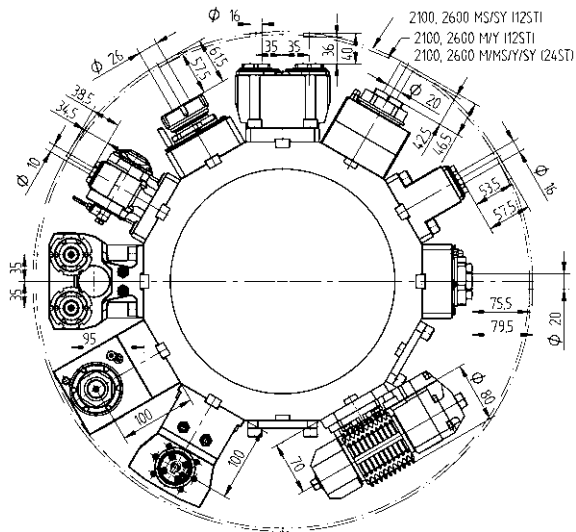

Driven Toolholders - Enhanced Program

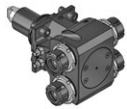

**2-spindle - Right angle drill/milling unit, both sides, Y axis**  
**ER 25** 413502008-65 1:1 EC  
 00675000915



**Broaching unit for ID and OD**  
**Type 32** 414532000-65 1:1 EC



**Broaching unit for ID and OD**  
**Type 52** 414552000-65 1:1 EC

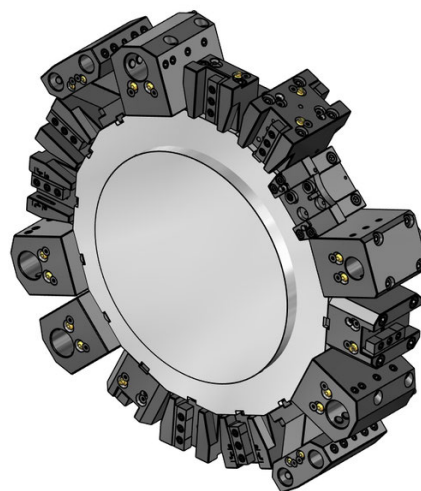
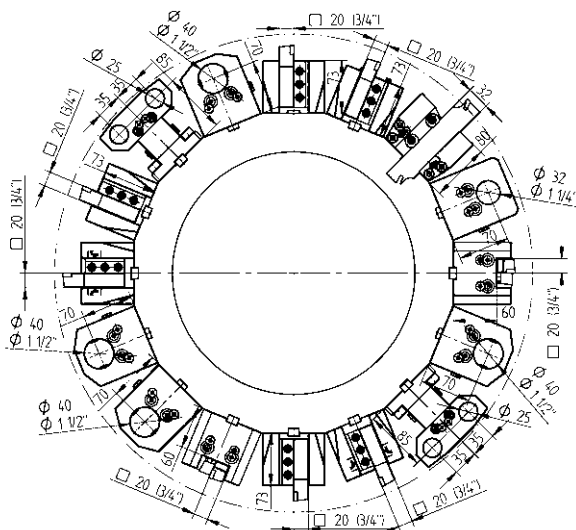

Static Toolholders - Standard Program

Static Toolholders - Standard Program



20  
3/4"

**OD cutting holder**

48-92036  
48-92037



20  
3/4"

**OD cutting holder, HP-IC**

48-92036-HP                      IC 80 bar  
48-92037-HP                      IC 80 bar



20  
3/4"

**OD cutting holder, both sides**

48-92038  
48-92039



20  
3/4"

**OD cutting holder, both sides, HP-IC**

48-92038-HP                      IC 80 bar  
48-92039-HP                      IC 80 bar



20  
3/4"

**Face cutting holder**

48-92045  
48-92046



20  
3/4"

**Face cutting holder, HP-IC**

48-92045-HP                      IC 80 bar  
48-92046-HP                      IC 80 bar



Ø 32  
Ø 40  
Ø 1 1/4"  
Ø 1 1/2"

**Combination toolholder, LF=70**

48-106897                      IC 80 bar  
48-87103                      IC 80 bar  
48-106872                      IC 80 bar  
48-87104                      IC 80 bar



48-87111

**Cover plate**



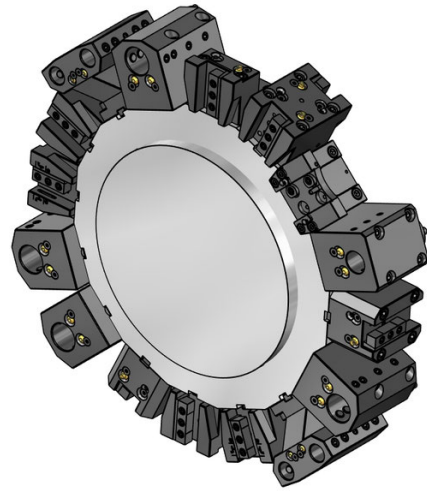
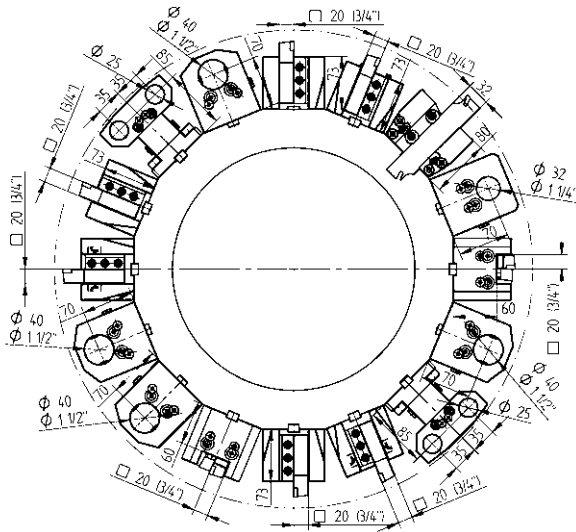

Static Toolholders - Enhanced Program



SH 32

**Cut-off holder, adjustable**

48-103287



SH 32

**Cut-off holder, adjustable, HP-IC**

48-110160R

IC 80 bar

SH 32

48-110160L

IC 80 bar



Ø 25

**Boring bar holder, both sides, double, Y axis, short**

48-98353

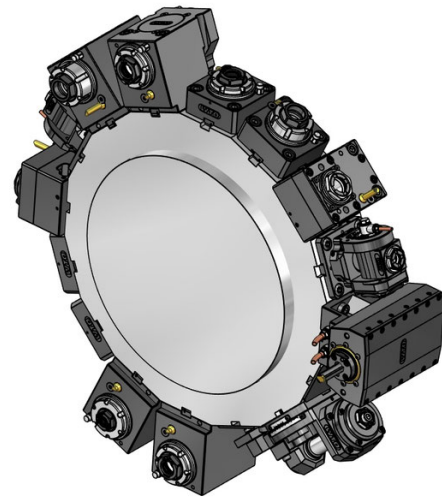
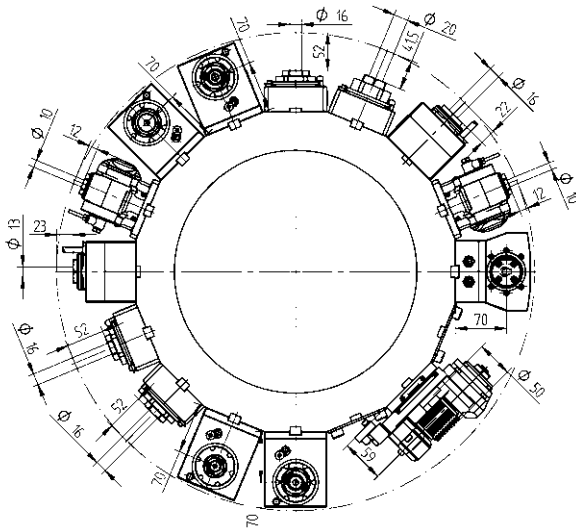

Driven Toolholders - QuickFlex®



- Straight drill/milling unit**
- |                 |              |     |           |
|-----------------|--------------|-----|-----------|
| <b>ER-25 QF</b> | 420125015-55 | 1:1 | EC        |
|                 | 0067725000   |     |           |
| <b>ER-25 QF</b> | 420125016-55 | 1:1 | IC 80 bar |
|                 | 0067725000   |     |           |



- Right angle drill/milling unit, LF=70**
- |                 |              |     |           |
|-----------------|--------------|-----|-----------|
| <b>ER-25 QF</b> | 420525015-55 | 1:1 | EC        |
|                 | 0067725000   |     |           |
| <b>ER-25 QF</b> | 420525016-55 | 1:1 | IC 80 bar |
|                 | 0067725000   |     |           |



- Right angle drill/milling unit, both sides, LF=70**
- |                 |              |     |    |
|-----------------|--------------|-----|----|
| <b>ER-25 QF</b> | 420525017-55 | 1:1 | EC |
|                 | 0067725000   |     |    |

Driven Toolholders - Enhanced Program



- Straight drill/milling unit**
- |              |              |     |           |
|--------------|--------------|-----|-----------|
| <b>ER 32</b> | 410120010-55 | 1:1 | EC        |
|              | 0067725000   |     |           |
| <b>ER 32</b> | 410120011-55 | 1:1 | IC 80 bar |
|              | 0067725000   |     |           |



- Straight milling unit with combination mill arbor DIN 6358**
- |               |              |     |    |
|---------------|--------------|-----|----|
| <b>Ø 22</b>   | 410222004-55 | 1:1 | EC |
|               | 00675000483  |     |    |
| <b>Ø 3/4"</b> | 410219002-55 | 1:1 | EC |
|               | 00675000483  |     |    |



- Straight offset drill/milling unit**
- |              |              |     |           |
|--------------|--------------|-----|-----------|
| <b>ER 25</b> | 410116029-55 | 1:1 | EC        |
|              | 00675000932  |     |           |
| <b>ER 25</b> | 410116030-55 | 1:1 | IC 80 bar |
|              | 00675000932  |     |           |
| <b>ER 20</b> | 410113009-55 | 1:2 | EC        |
|              | 00675000939  |     |           |
| <b>ER 20</b> | 410113010-55 | 1:2 | IC 80 bar |
|              | 00675000939  |     |           |
| <b>ER 16</b> | 410410004-55 | 1:3 | EC        |
|              | 00675000937  |     |           |
| <b>ER 16</b> | 410410005-55 | 1:3 | IC 80 bar |
|              | 00675000937  |     |           |

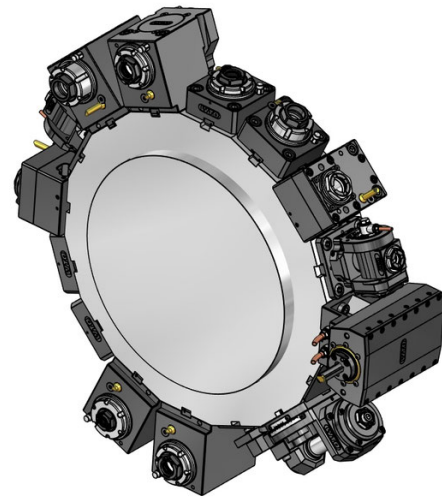
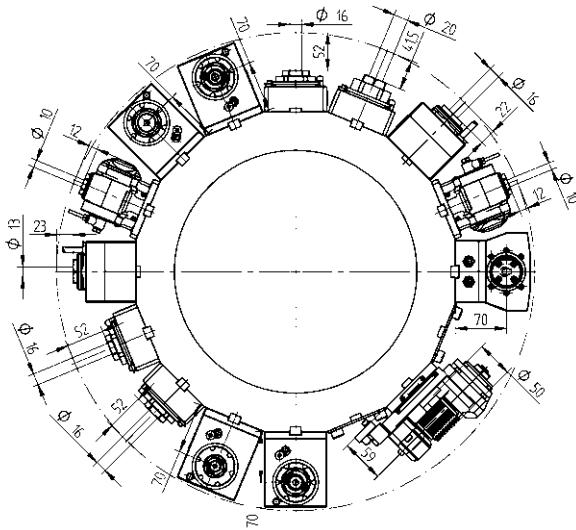

Driven Toolholders - Enhanced Program



<b>ER 32</b>	<b>Right angle drill/milling unit, LF=70</b>			
	410520033-55	1:1	EC	
	0067725000			
<b>ER 32</b>	410520034-55	1:1	IC 80 bar	
	0067725000			
<b>ER-20 QF</b>	420520012-55	1:2	EC	
	0067720001			
<b>ER-20 QF</b>	420520013-55	1:2	IC 80 bar	
	0067720001			
<b>ER 16</b>	410810016-55	1:3	EC	
	00675000841			
<b>ER 16</b>	410810017-55	1:3	IC 80 bar	
	00675000841			
<b>ER-25 QF</b>	420525030-55	2:1	EC	
	0067725000			
<b>ER-25 QF</b>	420525031-55	2:1	IC 80 bar	
	0067725000			



	<b>Right angle milling unit with combination mill arbor DIN 6358, LF=70</b>			
<b>Ø 22</b>	410622010-55	1:1	EC	
	00675000483			
<b>Ø 3/4"</b>	410619005-55	1:1	EC	
	00675000483			



	<b>Right angle back set drill/milling unit</b>			
<b>ER 25</b>	410516024-55	1:1	EC	
	00675000801			
<b>ER 25</b>	410516025-55	1:1	IC 80 bar	
	00675000801			

Driven Toolholders - Enhanced Program



	<b>Adjustable angle drill/milling unit</b>			
<b>ER 16</b>	411010005-55	1:1	EC	
	00675000902			
<b>ER 16</b>	411010006-55	1:1	IC 80 bar	
	00675000902			
<b>ER 11</b>	411007007-55	1:2	EC	
	00675000914			
<b>ER 11</b>	411007008-55	1:2	IC 80 bar	
	00675000914			

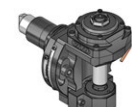

	<b>Gear hobbing unit</b>			
<b>Type 15-2</b>	410900002-55	1:1	EC	
	00675001015			
	160008152 Ø 8			
	160010152 Ø 10			
	160013152 Ø 13			
	160016152 Ø 16			
	160022152 Ø 22			
	160015152 Ø 5/8"			
	160019152 Ø 3/4"			
	110587			



	<b>Broaching unit for ID and OD</b>			
<b>Type 32</b>	414532001-55	1:1	EC	
<b>Type 52</b>	414552000-55	1:1	EC	

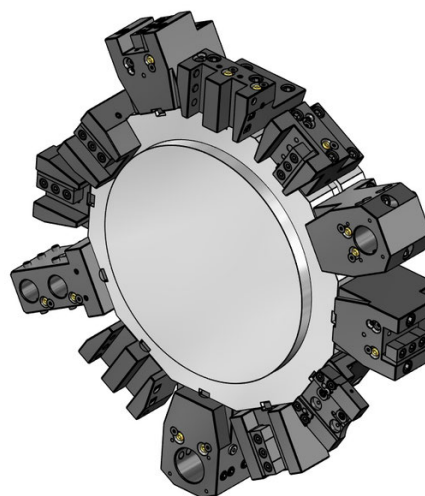
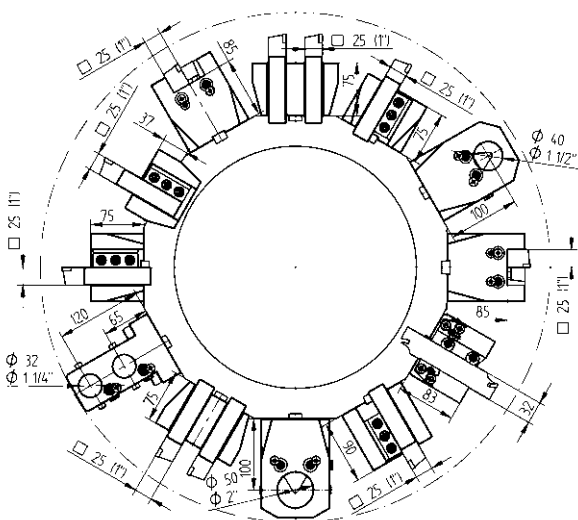

Static Toolholders - Standard Program

Static Toolholders - Standard Program



25  
1"

**OD cutting holder**

48-92428  
48-92466



25  
1"

**OD cutting holder, HP-IC**

48-92428-HP IC 80 bar  
48-92466-HP IC 80 bar



25  
1"

**OD cutting holder, both sides**

48-92438  
48-92472



25  
1"

**OD cutting holder, both sides, HP-IC**

48-92438-HP IC 80 bar  
48-92472-HP IC 80 bar



25  
1"

**Face cutting holder, long**

48-92958  
48-92959



Ø 40

**Combination toolholder, LF=100**

48-92397 IC 80 bar

241140020 ER32

241140026 ER40

Ø 50

48-92467 IC 80 bar

Ø 1 1/2"

48-92468 IC 80 bar

2411150020 ER32

Ø 2"

48-92469 IC 80 bar

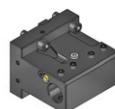

Ø 32

**Boring bar holder, both sides**

48-101033

Ø 1 1/4"

48-113514



Ø 32

**Boring bar holder, double**

48-84524

Ø 1 1/4"

48-86905



48-87089

**Cover plate**

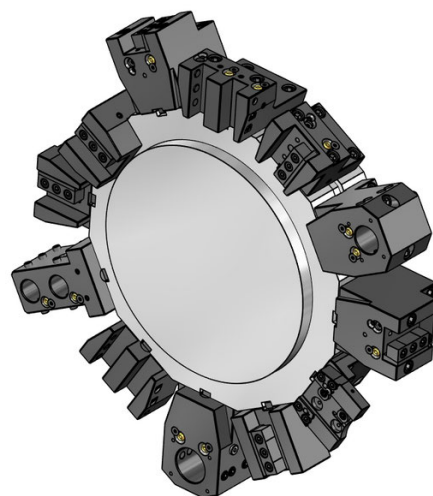
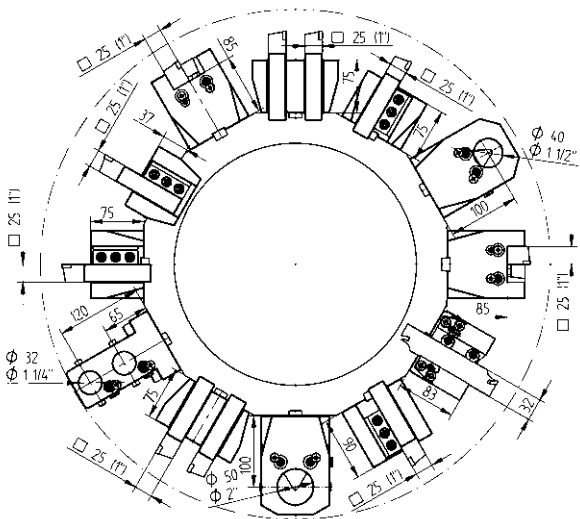

Static Toolholders - Enhanced Program

Static Toolholders - Enhanced Program



25  
1"

**OD cutting holder, short**

48-86991  
48-86992



25  
1"

**OD cutting holder, short, HP-IC**

48-86991-HP IC 80 bar  
48-86992-HP IC 80 bar



25  
1"

**OD cutting holder, long**

48-86711  
48-86712



25(1")

**OD cutting holder, double, Y axis**

48-86103



25(1")

**OD cutting holder, both sides, double, Y axis**

48-86150



SH 32

**Cut-off holder, adjustable**

48-99060



SH 32  
SH 32

**Cut-off holder, adjustable, HP-IC**

48-102256R IC 80 bar  
48-102256L C 80 bar



SH 32  
SH 32

**Cut-off holder, adjustable, long, HP-IC**

48-100082R IC 80 bar  
48-100082L IC 80 bar



Ø 50

**Boring bar holder, with slot, LF=100**

48-119005 EC



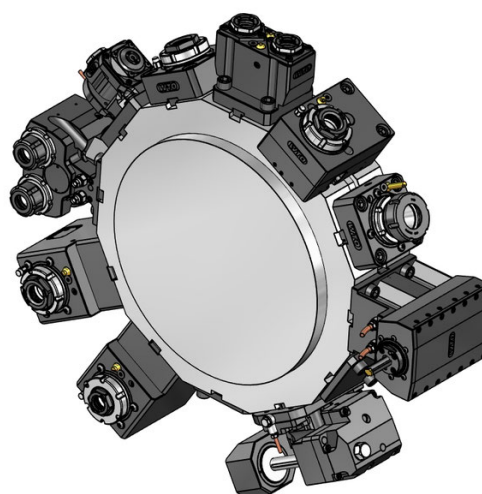
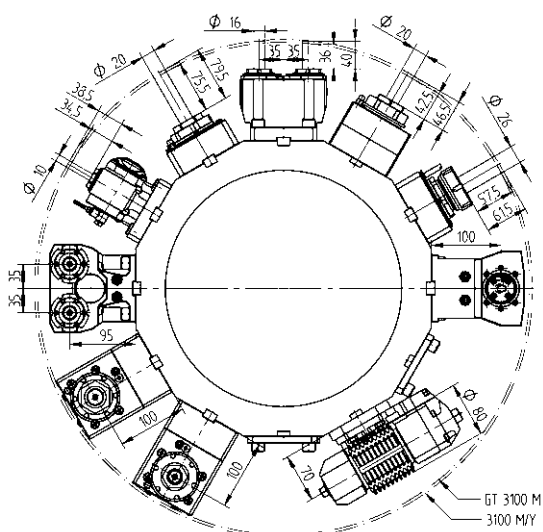

Driven Toolholders - QuickFlex®



**Straight drill/milling unit**

- ER-32 QF** QF32-DNE-BT65A-058-E-A 1:1 EC  
0067732000
- ER-32 QF** QF32-DNE-BT65A-060-I-A 1:1 IC 100 bar  
0067732000



**Straight drill/milling unit - QF smart (EU, US, CA, JP)**

- ER-32 QF** QF32-DNE-BT65A-060-I-SB-A 1:1 IC 100 bar  
0067732000
- LI-F12-01



**Right angle drill/milling unit, LF=100**

- ER-32 QF** 420532018-65 1:1 EC  
0067732000
- ER-32 QF** QF32-DNI-BT65A-100-I-A 1:1 IC 100 bar  
0067732000



**Right angle drill/milling unit - QF smart (EU, US, CA, JP), LF=100**

- ER-32 QF** QF32-DNI-BT65A-100-I-SB-A 1:1 IC 100 bar  
0067732000
- LI-F12-01



**Right angle drill/milling unit, both sides, LF=100**

- ER-32 QF** 420532020-65 1:1 EC  
0067732000

Driven Toolholders - Enhanced Program



**Straight drill/milling unit**

- ER 40** ER40-DNE-BT65A-084-E-A 1:1 EC  
00675000079
- ER 40** ER40-DNE-BT65A-086-I-A 1:1 IC 100 bar  
00675000079



**Straight offset drill/milling unit**

- ER-32 QF** 420132037-65 1:1 EC  
0067732000
- ER-32 QF** 420132038-65 1:1 IC 80 bar  
0067732000
- ER-25 QF** 420125010-65 1:2 EC  
0067725001
- ER-25 QF** 420125011-65 1:2 IC 80 bar  
0067725001



**Right angle drill/milling unit, LF=100**

- ER 40** 410526007-65 1:1 EC  
00675000079
- ER 40** 410526008-65 1:1 IC 80 bar  
00675000079

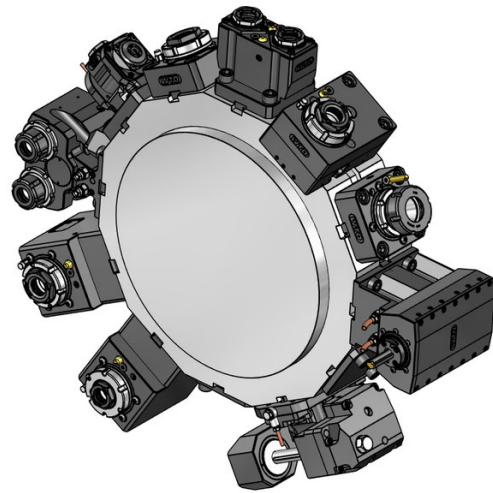
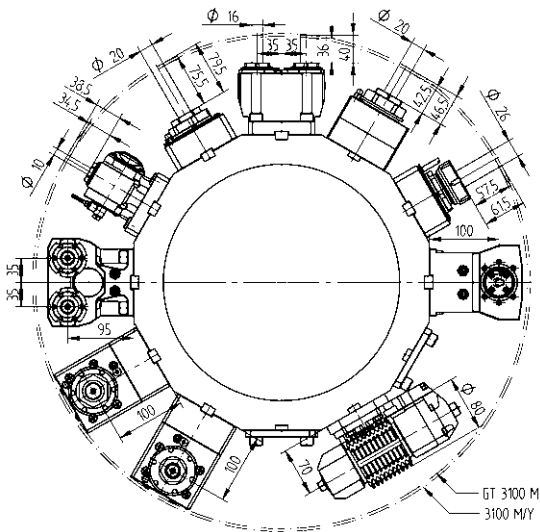

Driven Toolholders - Enhanced Program

Driven Toolholders - Enhanced Program



<b>Right angle drill/milling unit, LF=100</b>			
<b>ER-25 QF</b>	QF25-DNI-BT65A-100-E-S-A	1:2	EC
	0067725001		
<b>ER-25 QF</b>	QF25-DNI-BT65A-100-I-S-A	1:2	IC 100 bar
	0067725001		
<b>ER-32 QF</b>	QF32-DNI-BT65A-100-E-T-A	2:1	EC
	0067732000		
<b>ER-32 QF</b>	QF32-DNI-BT65A-100-I-T-A	2:1	IC 100 bar
	0067732000		



<b>Right angle back set drill/milling unit</b>			
<b>ER-32 QF</b>	420532090-65	1:1	EC
	0067732000		
<b>ER-32 QF</b>	420532091-65	1:1	IC 80 bar
	0067732000		



<b>Adjustable angle drill/milling unit</b>			
<b>ER 16</b>	411010002-65	1:1	EC
	00675000902		
<b>ER 16</b>	411010003-65	1:1	IC 80 bar
	00675000902		
<b>ER 11</b>	411007002-65	1:2	EC
	00675000914		
<b>ER 11</b>	411007003-65	1:2	IC 80 bar
	00675000914		



<b>Gear hobbing unit</b>			
<b>Type 16-1</b>	411500003-65	1:1	EC
<b>Type 16-1</b>	411500002-65	2:1	EC
	00675000927		
	160016161 Ø 16		
	160022161 Ø 22		
	160027161 Ø 27		
	160015161 Ø 5/8"		
	160019161 Ø 3/4"		
	160025161 Ø 1"		
	160031161 Ø 1 1/4"		
	110587		



<b>Straight drill/milling unit, double, Y axis</b>			
<b>ER 25</b>	413002004-65	1:1	EC
	00675000907		

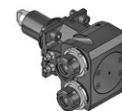

<b>2-spindle - Right angle drill/milling unit, Y axis</b>			
<b>ER 25</b>	413502006-65	1:1	EC
	00675000915		



<b>ER 25</b>	413502007-65	1:1	IC 80 bar
	00675000915		

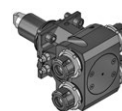

<b>2-spindle - Right angle drill/milling unit, both sides, Y axis</b>			
<b>ER 25</b>	413502008-65	1:1	EC
	00675000915		

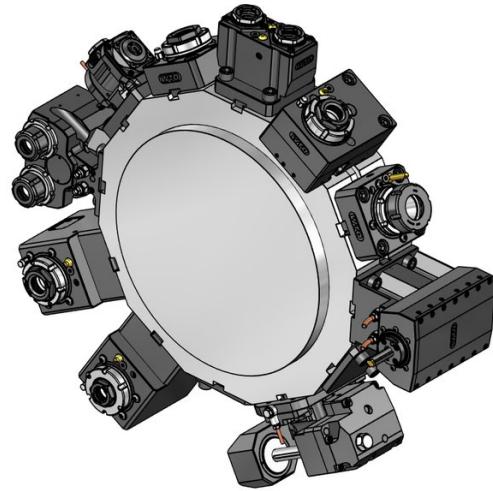
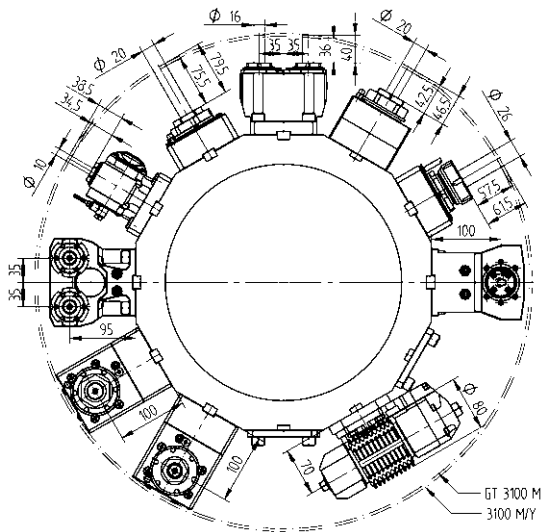

Driven Toolholders - Enhanced Program



**Broaching unit for ID and OD**  
**Type 32** 414532000-65 1:1 EC



**Broaching unit for ID and OD**  
**Type 52** 414552000-65 1:1 EC

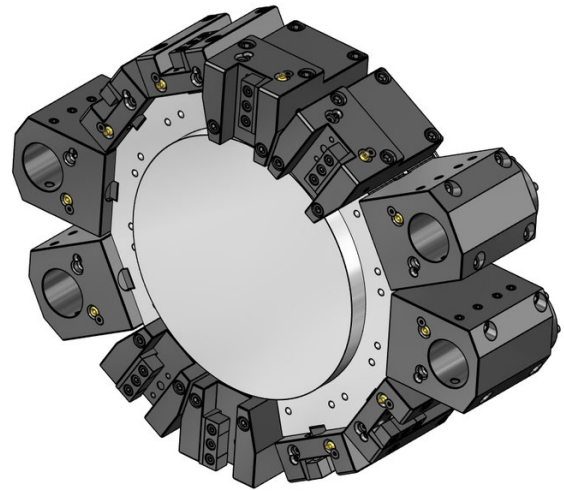
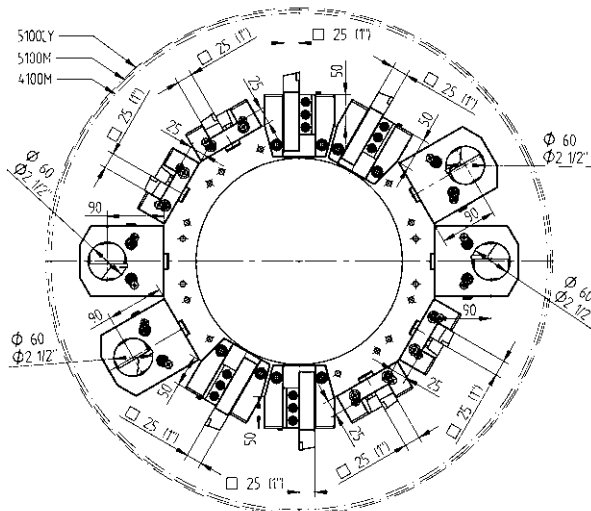

Static Toolholders - Standard Program

Static Toolholders - Enhanced Program



25  
1"

**OD cutting holder**

48-96421  
48-96422



25  
1"

**OD cutting holder, HP-IC**

48-96421-HP IC 80 bar  
48-96422-HP IC 80 bar



25  
1"

**Face cutting holder**

48-96355  
48-96357



$\phi 60$   
 $\phi 2 1/2"$

**Combination toolholder, LF=90**

48-104448 IC 80 bar  
48-104449 IC 80 bar



25(1")

**OD cutting holder, double, Y axis**

48-112317



VDI 50

**VDI adapter, right, LF=110**

48-112600

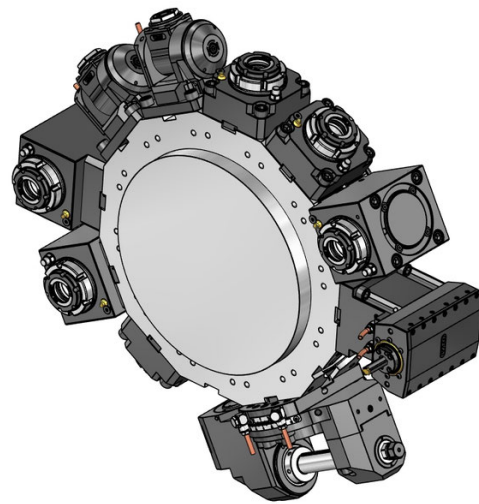
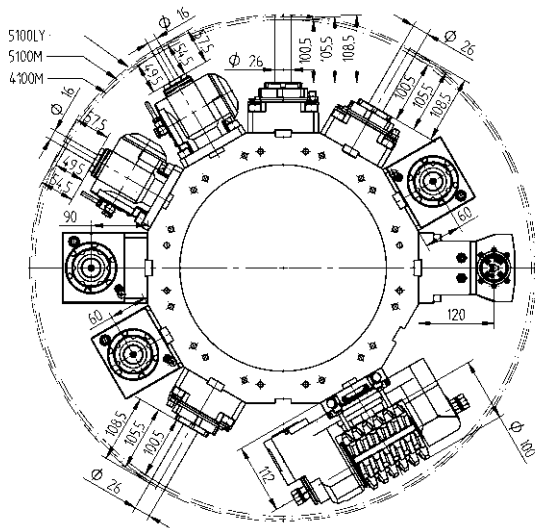

Driven Toolholders - QuickFlex®



- OD drill/milling unit**
- |                 |              |     |           |
|-----------------|--------------|-----|-----------|
| <b>ER-40 QF</b> | 420140015-75 | 1:1 | EC        |
|                 | 0067740000   |     |           |
| <b>ER-40 QF</b> | 420140016-75 | 1:1 | IC 80 bar |
|                 | 0067740000   |     |           |



- Face drill/milling unit, LF=60**
- |                 |              |     |           |
|-----------------|--------------|-----|-----------|
| <b>ER-40 QF</b> | 420540015-75 | 1:1 | EC        |
|                 | 0067740000   |     |           |
| <b>ER-40 QF</b> | 420540016-75 | 1:1 | IC 80 bar |
|                 | 0067740000   |     |           |



- Face drill/milling unit, LF=90**
- |                 |              |     |           |
|-----------------|--------------|-----|-----------|
| <b>ER-40 QF</b> | 420540017-75 | 1:1 | EC        |
|                 | 0067740000   |     |           |
| <b>ER-40 QF</b> | 420540018-75 | 1:1 | IC 80 bar |
|                 | 0067740000   |     |           |

Driven Toolholders - Enhanced Program



- Face drill/milling unit, LF=60**
- |                 |              |     |           |
|-----------------|--------------|-----|-----------|
| <b>ER-32 QF</b> | 420532010-75 | 1:2 | EC        |
|                 | 0067732001   |     |           |
| <b>ER-32 QF</b> | 420532011-75 | 1:2 | IC 80 bar |
|                 | 0067732001   |     |           |
| <b>ER-40 QF</b> | 420540021-75 | 2:1 | EC        |
|                 | 0067740000   |     |           |
| <b>ER-40 QF</b> | 420540022-75 | 2:1 | IC 80 bar |
|                 | 0067740000   |     |           |



- Adjustable angle drill/milling unit**
- |              |              |     |           |
|--------------|--------------|-----|-----------|
| <b>ER 25</b> | 411016000-75 | 1:1 | EC        |
|              | 00675000934  |     |           |
| <b>ER 25</b> | 411016001-75 | 1:1 | IC 80 bar |
|              | 00675000934  |     |           |
| <b>ER 16</b> | 411010002-75 | 1:2 | EC        |
|              | 00675000936  |     |           |
| <b>ER 16</b> | 411010003-75 | 1:2 | IC 80 bar |
|              | 00675000936  |     |           |



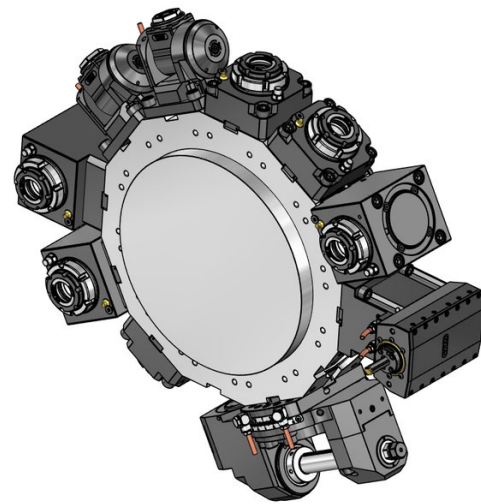
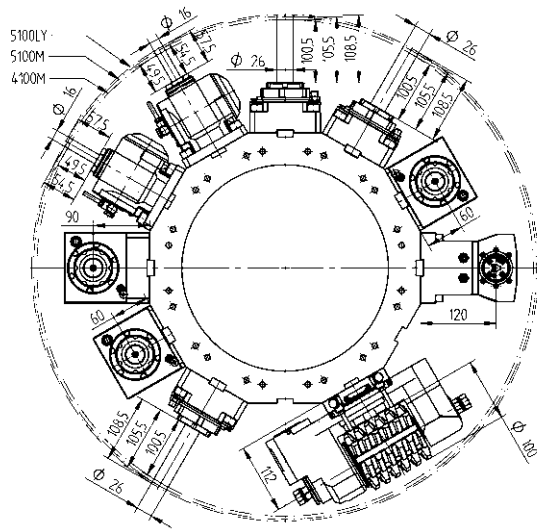

Driven Toolholders - Enhanced Program



**Gear hobbing unit**

- |                  |                    |     |    |
|------------------|--------------------|-----|----|
| <b>Type C5-1</b> | 410900001-75       | 2:1 | EC |
|                  | 00675001008        |     |    |
|                  | 160022C51 Ø 22     |     |    |
|                  | 160027C51 Ø 27     |     |    |
|                  | 160032C51 Ø 32     |     |    |
|                  | 160015C51 Ø 5/8"   |     |    |
|                  | 160019C51 Ø 3/4"   |     |    |
|                  | 160025C51 Ø 1"     |     |    |
|                  | 160031C51 Ø 1 1/4" |     |    |
|                  | 110587             |     |    |



**Broaching unit for ID and OD**

- |                |              |     |    |
|----------------|--------------|-----|----|
| <b>Type 32</b> | 414532000-75 | 1:1 | EC |
| <b>Type 52</b> | 414552000-75 | 1:1 | EC |

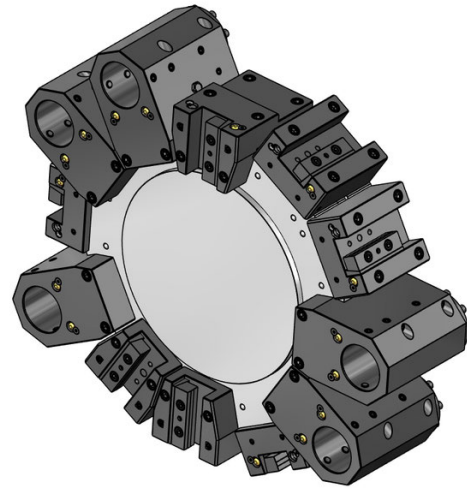
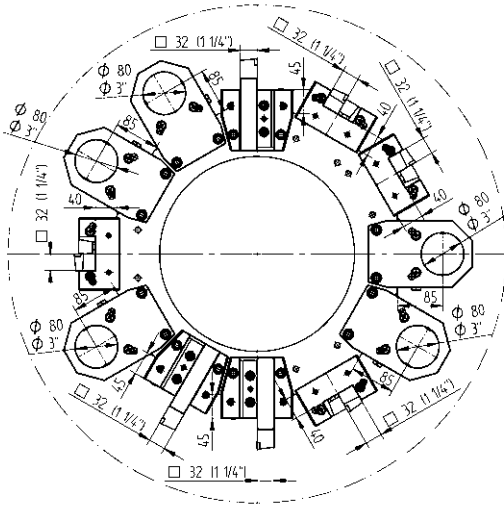

Static Toolholders - Standard Program



**OD cutting holder**

<b>32</b>	48-95667
<b>1 1/4"</b>	48-95668



**Face cutting holder**

<b>32</b>	48-95669
<b>1 1/4"</b>	48-95670



**Combination toolholder**

<b>Ø 80</b>	48-95671	IC 80 bar
<b>Ø 3"</b>	48-95672	IC 80 bar

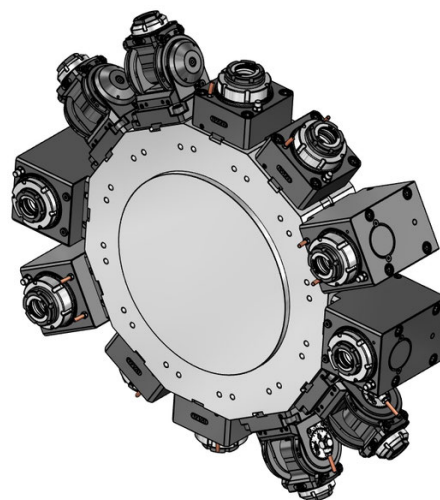
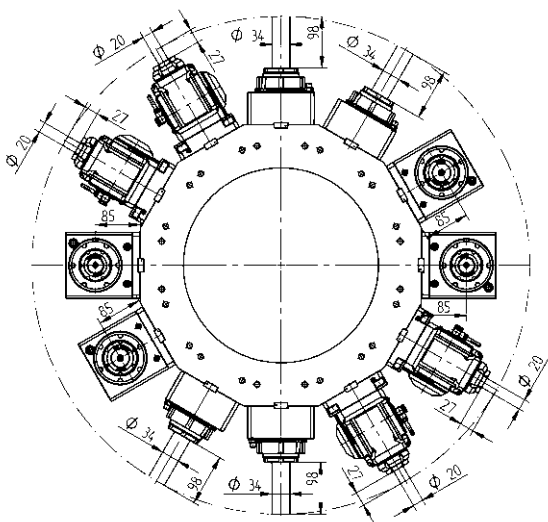

Driven Toolholders - QuickFlex®



**OD drill/milling unit**

- ER-50 QF** 420150015-85 1:1 EC  
0067750000
- ER-50 QF** 420150016-85 1:1 IC 80 bar  
0067750000



**Face drill/milling unit, LF=85**

- ER-50 QF** 420550015-85 1:1 EC  
0067750000
- ER-50 QF** 420550016-85 1:1 IC 80 bar  
0067750000

Driven Toolholders - Enhanced Program



**Face drill/milling unit, LF=85**

- ER-40 QF** 420540015-85 1:2 EC  
0067740001
- ER-40 QF** 420540016-85 1:2 IC 80 bar  
0067740001



**Adjustable angle drill/milling unit**

- ER-32 QF** 421032010-85 1:1 EC  
00675000976
- ER-32 QF** 421032011-85 1:1 IC 80 bar  
00675000976



**Gear hobbing unit**

- Type C5-1** 410900000-85 2:1 EC  
00675001008
- 160022C51 Ø 22
- 160027C51 Ø 27
- 160032C51 Ø 32
- 160019C51 Ø 3/4"
- 160025C51 Ø 1"
- 160031C51 Ø 1 1/4"
- 110587

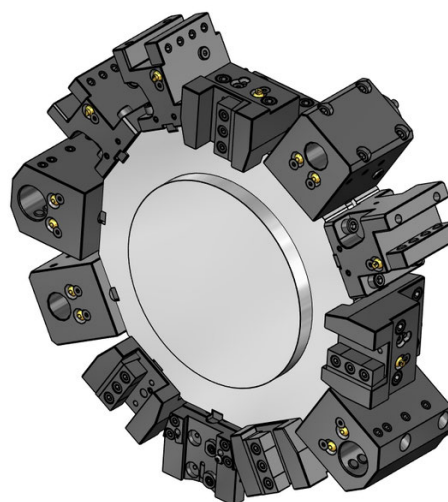
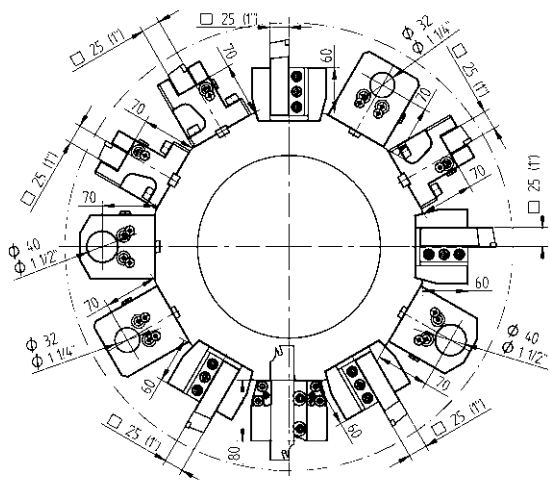

Static Toolholders - Standard Program

Static Toolholders - Enhanced Program



25  
1"

**OD cutting holder**

48-87097  
48-87098



25  
1"

**OD cutting holder, HP-IC**

48-87097-HP	IC 80 bar
48-87098-HP	IC 80 bar



25  
1"

**Face cutting holder**

48-87101  
48-87102



25  
1"

**Face cutting holder, HP-IC**

48-87101-HP	IC 80 bar
48-87102-HP	IC 80 bar



Ø 32  
Ø 40  
Ø 1 1/4"  
Ø 1 1/2"

**Combination toolholder, LF=70**

48-106897	IC 80 bar
48-87103	IC 80 bar
48-106872	IC 80 bar
48-87104	IC 80 bar



48-87111

**Cover plate**



SH 32

**Cut-off holder, adjustable**

48-103287



SH 32  
SH 32

**Cut-off holder, adjustable, HP-IC**

48-110160R	IC 80 bar
48-110160L	IC 80 bar

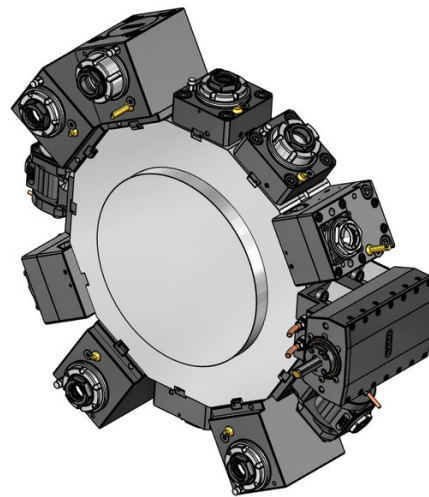
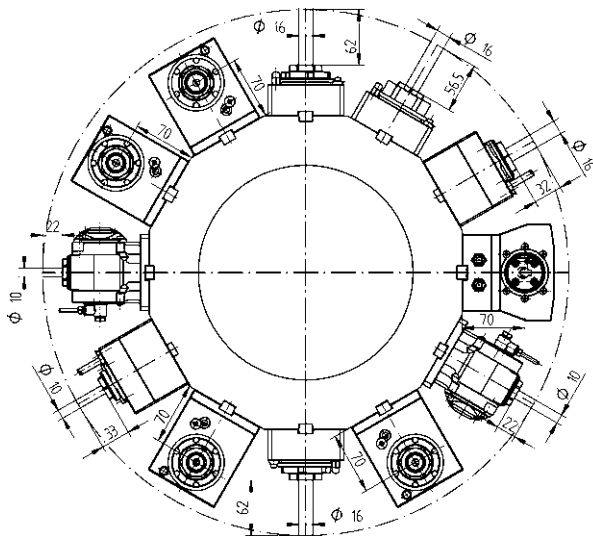

Driven Toolholders - QuickFlex®



- Straight drill/milling unit**
- |                 |              |     |           |
|-----------------|--------------|-----|-----------|
| <b>ER-25 QF</b> | 420125015-55 | 1:1 | EC        |
|                 | 0067725000   |     |           |
| <b>ER-25 QF</b> | 420125016-55 | 1:1 | IC 80 bar |
|                 | 0067725000   |     |           |



- Right angle drill/milling unit, LF=70**
- |                 |              |     |           |
|-----------------|--------------|-----|-----------|
| <b>ER-25 QF</b> | 420525015-55 | 1:1 | EC        |
|                 | 0067725000   |     |           |
| <b>ER-25 QF</b> | 420525016-55 | 1:1 | IC 80 bar |
|                 | 0067725000   |     |           |

Driven Toolholders - Enhanced Program



- Straight drill/milling unit**
- |              |              |     |           |
|--------------|--------------|-----|-----------|
| <b>ER 32</b> | 410120010-55 | 1:1 | EC        |
|              | 0067725000   |     |           |
| <b>ER 32</b> | 410120011-55 | 1:1 | IC 80 bar |
|              | 0067725000   |     |           |



- Straight milling unit with combination mill arbor DIN 6358**
- |               |              |     |    |
|---------------|--------------|-----|----|
| <b>Ø 22</b>   | 410222004-55 | 1:1 | EC |
|               | 00675000483  |     |    |
| <b>Ø 3/4"</b> | 410219002-55 | 1:1 | EC |
|               | 00675000483  |     |    |



- Straight offset drill/milling unit**
- |              |              |     |           |
|--------------|--------------|-----|-----------|
| <b>ER 25</b> | 410116029-55 | 1:1 | EC        |
|              | 00675000932  |     |           |
| <b>ER 25</b> | 410116030-55 | 1:1 | IC 80 bar |
|              | 00675000932  |     |           |
| <b>ER 20</b> | 410113009-55 | 1:2 | EC        |
|              | 00675000939  |     |           |
| <b>ER 20</b> | 410113010-55 | 1:2 | IC 80 bar |
|              | 00675000939  |     |           |
| <b>ER 16</b> | 410410004-55 | 1:3 | EC        |
|              | 00675000937  |     |           |
| <b>ER 16</b> | 410410005-55 | 1:3 | IC 80 bar |
|              | 00675000937  |     |           |



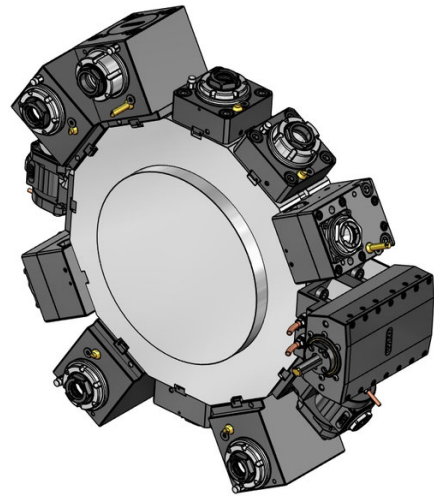
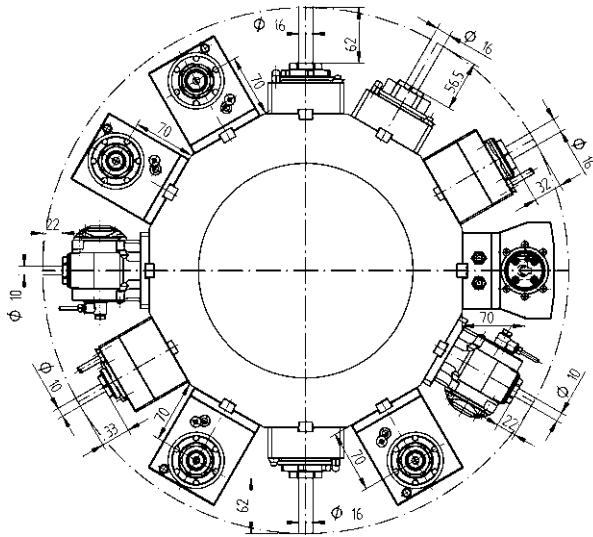

Driven Toolholders - Enhanced Program



**Right angle drill/milling unit, LF=70**

<b>ER 32</b>	410520033-55 0067725000	1:1	EC
<b>ER 32</b>	410520034-55 0067725000	1:1	IC 80 bar
<b>ER-20 QF</b>	420520012-55 0067720001	1:2	EC
<b>ER-20 QF</b>	420520013-55 0067720001	1:2	IC 80 bar
<b>ER 16</b>	410810016-55 00675000841	1:3	EC
<b>ER 16</b>	410810017-55 00675000841	1:3	IC 80 bar
<b>ER-25 QF</b>	420525030-55 0067725000	2:1	EC
<b>ER-25 QF</b>	420525031-55 0067725000	2:1	IC 80 bar

Driven Toolholders - Enhanced Program



**Adjustable angle drill/milling unit**

<b>ER 16</b>	411010005-55 00675000902	1:1	EC
<b>ER 16</b>	411010006-55 00675000902	1:1	IC 80 bar
<b>ER 11</b>	411007007-55 00675000914	1:2	EC
<b>ER 11</b>	411007008-55 00675000914	1:2	IC 80 bar



**Broaching unit for ID and OD**

<b>Type 32</b>	414532001-55	1:1	EC
<b>Type 52</b>	414552000-55	1:1	EC



**Right angle milling unit with combination mill arbor DIN 6358, LF=70**

<b>Ø 22</b>	410622010-55 00675000483	1:1	EC
<b>Ø 3/4"</b>	410619005-55 00675000483	1:1	EC

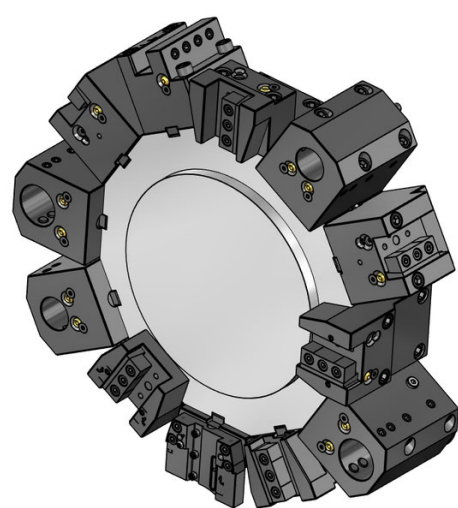
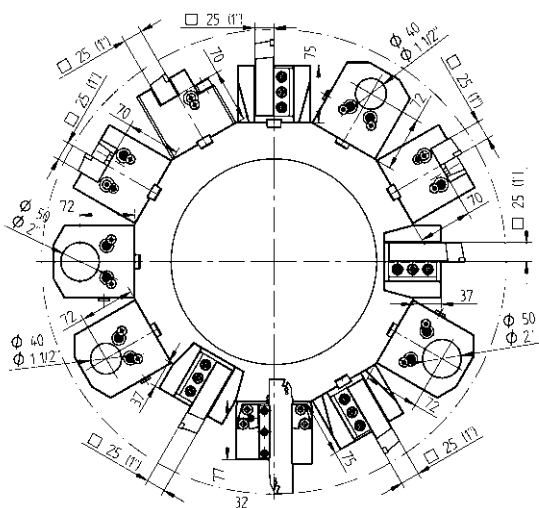

Static Toolholders - Standard Program

Static Toolholders - Standard Program



**OD cutting holder**  
 25 48-92428  
 1" 48-92466



**Face cutting holder**  
 25 48-86719  
 1" 48-86720



**OD cutting holder, HP-IC**  
 25 48-92428-HP IC 80 bar  
 1" 48-92466-HP IC 80 bar



**Face cutting holder, HP-IC**  
 25 48-109249-HP IC 80 bar  
 1" 48-109250-HP IC 80 bar

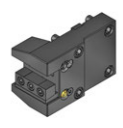

**OD cutting holder, short**  
 25 48-86991  
 1" 48-86992



**Combination toolholder, LF=72**  
 Ø 40 48-84375 IC 80 bar  
 Ø 1 1/2" 48-87077 IC 80 bar  
 Ø 50 48-107499 IC 80 bar  
 Ø 2" 48-107501 IC 80 bar



**OD cutting holder, short, HP-IC**  
 25 48-86991-HP IC 80 bar  
 1" 48-86992-HP IC 80 bar



**Cover plate**  
 48-87089



**Cut-off holder, adjustable**  
 SH 32 48-99060



**Cut-off holder, adjustable, HP-IC**  
 SH 32 48-102256R IC 80 bar  
 SH 32 48-102256L IC 80 bar

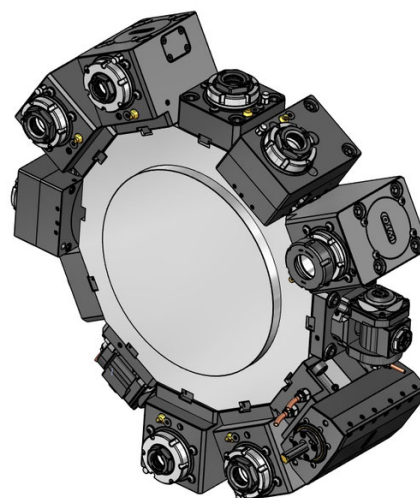
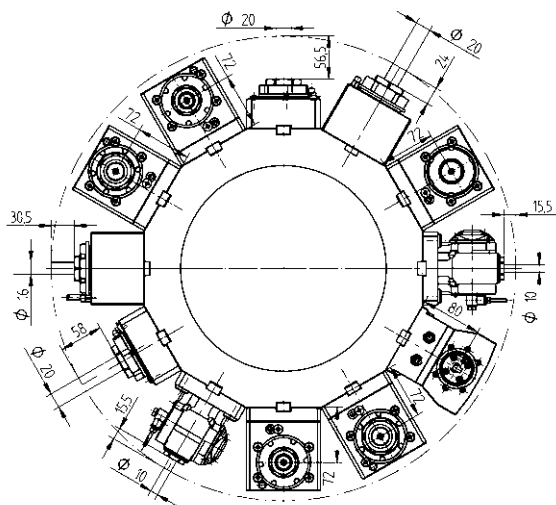

Driven Toolholders - QuickFlex®



- Straight drill/milling unit**
- ER-32 QF** QF32-DNE-BT65A-058-E-A 1:1 EC  
0067732000
  - ER-32 QF** QF32-DNE-BT65A-060-I-A 1:1 IC 100 bar  
0067732000



- Straight drill/milling unit (10000 RPM)**
- ER-32 QF** QF32-DNE-BT65A-058-E-HS-A 1:1 EC  
0067732000
  - ER-32 QF** QF32-DNE-BT65A-060-I-HS-A 1:1 IC 100 bar  
0067732000



- Straight drill/milling unit - QF smart (EU, US, CA, JP)**
- ER-32 QF** QF32-DNE-BT65A-060-I-SB-A 1:1 IC 100 bar  
0067732000  
LI-F12-01



- Straight drill/milling unit (10000 RPM) - QF smart (EU, US, CA, JP)**
- ER-32 QF** QF32-DNE-BT65A-060-I-HS-SB-A 1:1 IC 100 bar  
0067732000  
LI-F12-01

Driven Toolholders - QuickFlex®



- Right angle drill/milling unit, LF=72**
- ER-32 QF** 420532015-65 1:1 EC  
0067732000
  - ER-32 QF** 420532016-65 1:1 IC 80 bar  
0067732000



- Right angle drill/milling unit, LF=72, (10000 RPM)**
- ER-32 QF** QF32-DNI-BT65A-072-E-HS-A 1:1 EC  
0067732000
  - ER-32 QF** QF32-DNI-BT65A-072-I-HS-A 1:1 IC 100 bar  
0067732000



- Right angle drill/milling unit - QF smart (EU, US, CA, JP), LF=72**
- ER-32 QF** QF32-DNI-BT65A-072-I-SB-A 1:1 IC 100 bar  
0067732000  
LI-F12-01



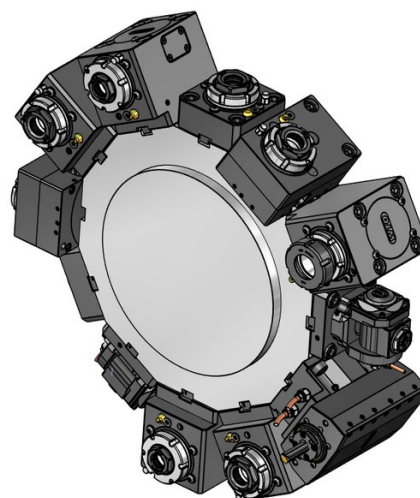
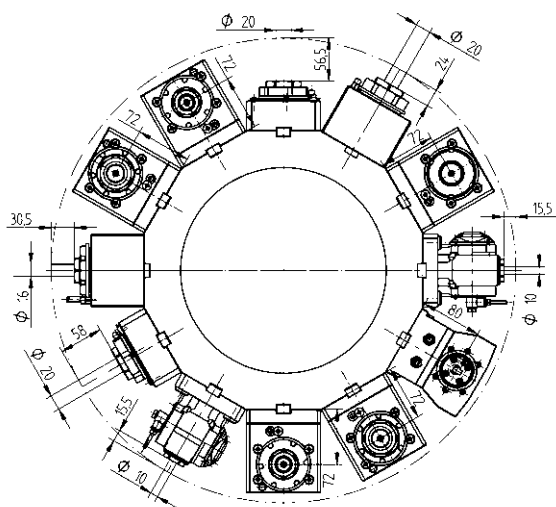

- Right angle drill/milling unit (10000 RPM) - QF smart (EU, US, CA, JP), LF=72**
- ER-32 QF** QF32-DNI-BT65A-072-I-HS-SB-A 1:1 IC 100 bar  
0067732000  
LI-F12-01



### Driven Toolholders - Enhanced Program







**Straight drill/milling unit**

<b>ER 40</b>	ER40-DNE-BT65A-084-E-A	1:1	EC
	 00675000079		
<b>ER 40</b>	ER40-DNE-BT65A-086-I-A	1:1	IC 100 bar
	 00675000079		





**Straight offset drill/milling unit**

<b>ER-32 QF</b>	420132037-65	1:1	EC
	 0067732000		
<b>ER-32 QF</b>	420132038-65	1:1	IC 80 bar
	 0067732000		
<b>ER-25 QF</b>	420125010-65	1:2	EC
	 0067725001		
<b>ER-25 QF</b>	420125011-65	1:2	IC 80 bar
	 0067725001		







**Right angle drill/milling unit, LF=72**

<b>ER 40</b>	ER40-DNI-BT65A-072-E-A	1:1	EC
	 00675000079		
<b>ER 40</b>	ER40-DNI-BT65A-072-I-A	1:1	IC 80 bar
	 00675000079		

### Driven Toolholders - Enhanced Program







**Right angle drill/milling unit, LF=72**

<b>ER-25 QF</b>	QF25-DNI-BT65A-072-E-S-A	1:2	EC
	 0067725001		
<b>ER-25 QF</b>	QF25-DNI-BT65A-072-I-S-A	1:2	IC 100 bar
	 0067725001		
<b>ER-32 QF</b>	QF32-DNI-BT65A-072-E-T-A	2:1	EC
	 0067732000		
<b>ER-32 QF</b>	QF32-DNI-BT65A-072-I-T-A	2:1	IC 100 bar
	 0067732000		



**Adjustable angle drill/milling unit**

<b>ER 16</b>	411010002-65	1:1	EC
	 00675000902		
<b>ER 16</b>	411010003-65	1:1	IC 80 bar
	 00675000902		
<b>ER 11</b>	411007002-65	1:2	EC
	 00675000914		
<b>ER 11</b>	411007003-65	1:2	IC 80 bar
	 00675000914		

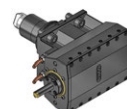

**Broaching unit for ID and OD**

<b>Type 32</b>	414532001-65	1:1	EC
<b>Type 52</b>	414552001-65	1:1	EC

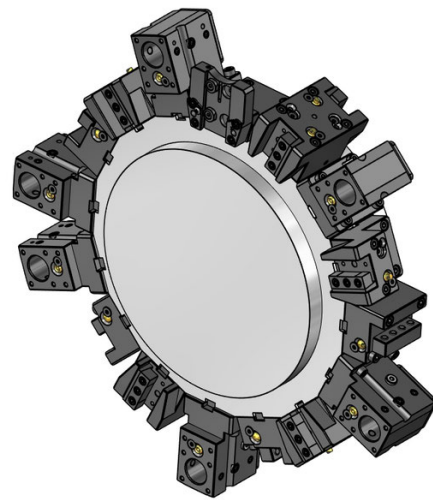
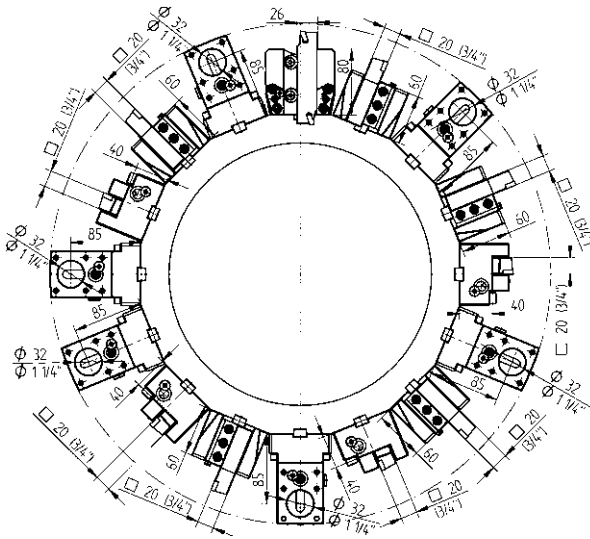

Static Toolholders - Standard Program

Static Toolholders - Standard Program



20  
3/4"

**OD cutting holder**

48-95083  
48-95084



20  
3/4"

**OD cutting holder, HP-IC**

48-100605-HP IC 80 bar  
48-108926-HP IC 80 bar



25  
1"

**OD cutting holder, HP-IC**

48-104395-HP IC 80 bar  
48-104396-HP IC 80 bar



20  
3/4"

**OD cutting holder, both sides**

48-95085  
48-95086



20  
3/4"

**OD cutting holder, both sides, HP-IC**

48-95085-HP IC 80 bar  
48-95086-HP IC 80 bar



20

**Face cutting holder**

48-109148



3/4"

**Face cutting holder**

48-95338



20  
3/4"

**Face cutting holder, HP-IC**

48-109148-HP IC 80 bar  
48-109149-HP IC 80 bar

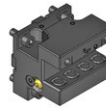

25  
1"

**Face cutting holder, HP-IC**

48-104397-HP IC 80 bar  
48-104398-HP IC 80 bar



SH 26

**Cut-off holder, adjustable**

48-94968



SH 26  
SH 26

**Cut-off holder, adjustable, HP-IC**

48-102252R IC 80 bar  
48-102252L IC 80 bar



Ø 32

**Combination toolholder, universal, LF=85**

48-95998 IC 80 bar

 241132016 ER25

 241132020 ER32

Ø 1 1/4"

48-96029 IC 80 bar

 2411125020 ER32



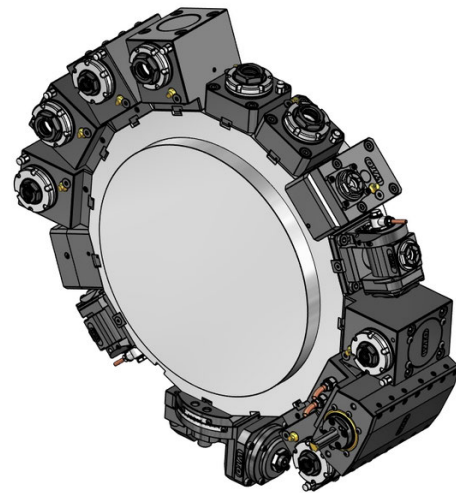
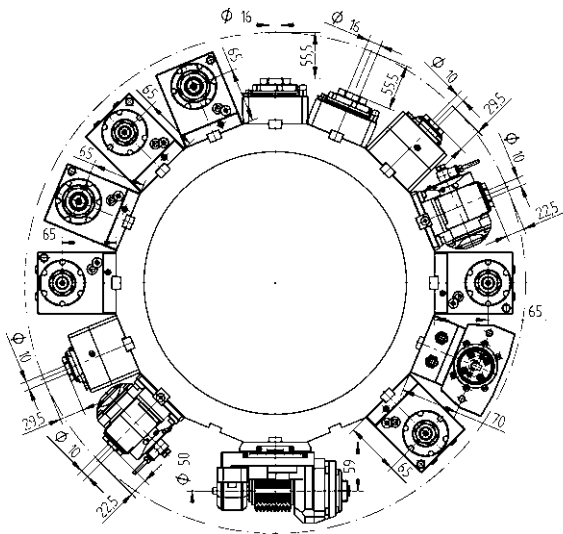

Driven Toolholders - QuickFlex®



- Straight drill/milling unit**
- |                 |              |     |           |
|-----------------|--------------|-----|-----------|
| <b>ER-25 QF</b> | 420125015-45 | 1:1 | EC        |
|                 | 0067725000   |     |           |
| <b>ER-25 QF</b> | 420125016-45 | 1:1 | IC 80 bar |
|                 | 0067725000   |     |           |



- Right angle drill/milling unit, LF=65**
- |                 |              |     |           |
|-----------------|--------------|-----|-----------|
| <b>ER-25 QF</b> | 420525015-45 | 1:1 | EC        |
|                 | 0067725000   |     |           |
| <b>ER-25 QF</b> | 420525016-45 | 1:1 | IC 80 bar |
|                 | 0067725000   |     |           |

Driven Toolholders - Enhanced Program



- Straight offset drill/milling unit**
- |              |              |     |           |
|--------------|--------------|-----|-----------|
| <b>ER 16</b> | 410410008-45 | 1:3 | EC        |
|              | 00675000937  |     |           |
| <b>ER 16</b> | 410410002-45 | 1:3 | IC 80 bar |
|              | 00675000937  |     |           |



- Right angle drill/milling unit, LF=65**
- |                 |              |     |           |
|-----------------|--------------|-----|-----------|
| <b>ER-20 QF</b> | 420520018-45 | 1:2 | EC        |
|                 | 0067720001   |     |           |
| <b>ER-20 QF</b> | 420520019-45 | 1:2 | IC 80 bar |
|                 | 0067720001   |     |           |
| <b>ER-25 QF</b> | 420525020-45 | 2:1 | EC        |
|                 | 0067725000   |     |           |
| <b>ER-25 QF</b> | 420525021-45 | 2:1 | IC 80 bar |
|                 | 0067725000   |     |           |



- Adjustable angle drill/milling unit**
- |              |              |     |           |
|--------------|--------------|-----|-----------|
| <b>ER 16</b> | 411010008-45 | 1:1 | EC        |
|              | 00675000902  |     |           |
| <b>ER 16</b> | 411010009-45 | 1:1 | IC 80 bar |
|              | 00675000902  |     |           |
| <b>ER 11</b> | 411007004-45 | 1:2 | EC        |
|              | 00675000914  |     |           |
| <b>ER 11</b> | 411007005-45 | 1:2 | IC 80 bar |
|              | 00675000914  |     |           |

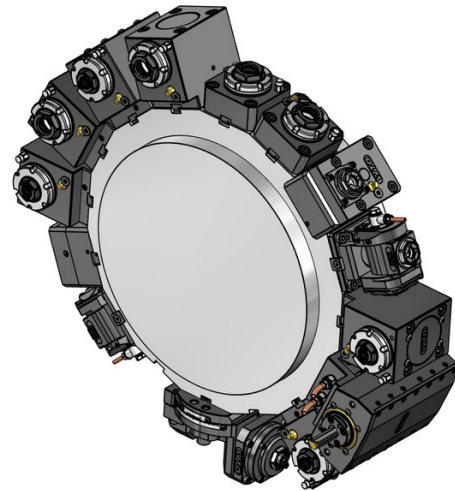
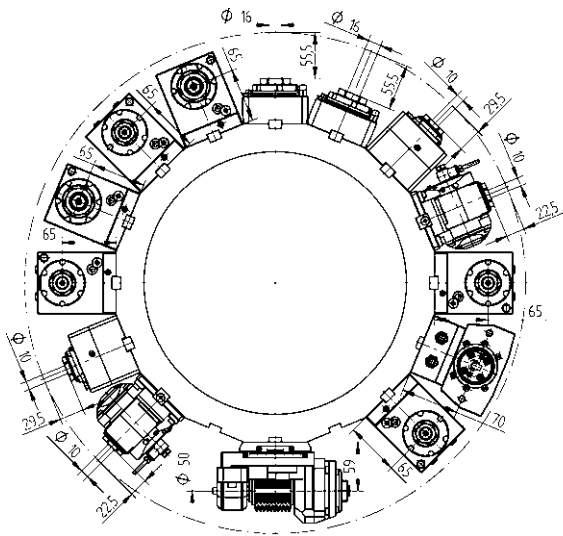

Driven Toolholders - Enhanced Program



**Gear hobbing unit**

Type 15-2 410900003-45 1:1 EC

-  00675001015
-  160008152 Ø 8
-  160010152 Ø 10
-  160013152 Ø 13
-  160016152 Ø 16
-  160022152 Ø 22
-  160015152 Ø 5/8"
-  160019152 Ø 3/4"
-  110587



**Broaching unit for ID and OD**

Type 32 414532005-45 1:1 EC

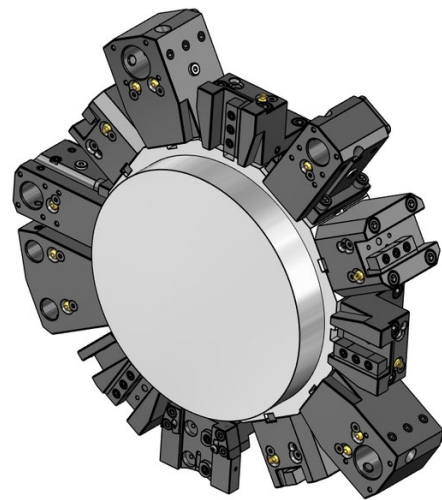
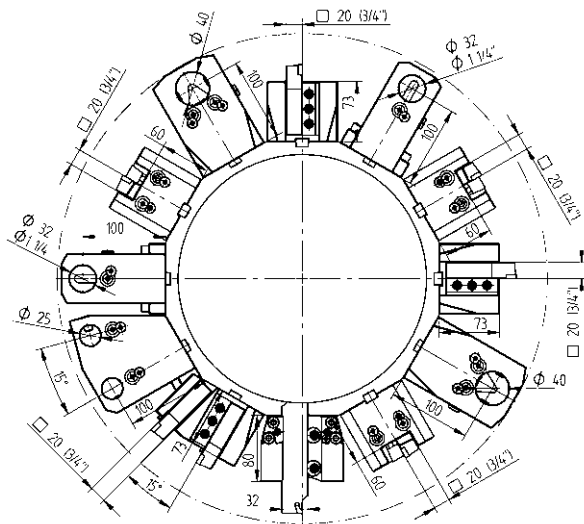

Static Toolholders - Standard Program

Static Toolholders - Standard Program



**OD cutting holder**  
 20 48-92036  
 3/4" 48-92037



**OD cutting holder, HP-IC**  
 20 48-92036-HP IC 80 bar  
 3/4" 48-92037-HP IC 80 bar



**OD cutting holder, both sides**  
 20 48-92038  
 3/4" 48-92039



**OD cutting holder, both sides, HP-IC**  
 20 48-92038-HP IC 80 bar  
 3/4" 48-92039-HP IC 80 bar



**Face cutting holder**  
 20 48-92045  
 3/4" 48-92046



**Face cutting holder, HP-IC**  
 20 48-92045-HP IC 80 bar  
 3/4" 48-92046-HP IC 80 bar



**Combination toolholder, universal, LF=100**  
 Ø 32 48-92043 IC 80 bar

241132016 ER25

241132020 ER32

Ø 1 1/4" 48-92044 IC 80 bar

2411125020 ER32



**Combination toolholder, universal, LF=100**  
 Ø 40 48-103474 IC 80 bar

241140020 ER32

241140026 ER40

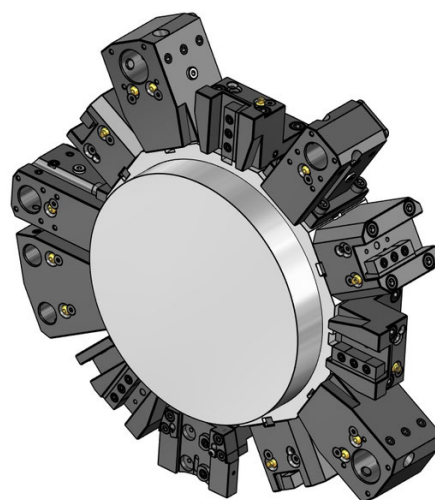
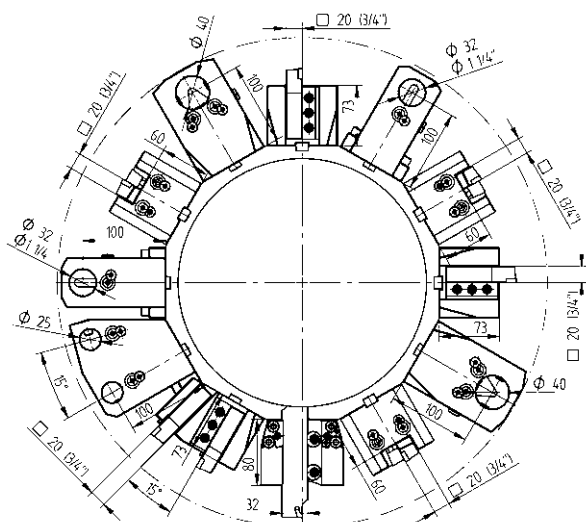

Static Toolholders - Enhanced Program



20

**OD cutting holder, double, 24 station**  
48-87674



20

**OD cutting holder, both sides, double, 24 station**  
48-92980



SH 32

**Cut-off holder, adjustable**  
48-103287



SH 32

**Cut-off holder, adjustable, HP-IC**  
48-110160R IC 80 bar

SH 32

48-110160L IC 80 bar



SH 32

**Cut-off holder, adjustable, long**  
48-103288



SH 32

**Cut-off holder, adjustable, long, HP-IC**  
48-111142R IC 80 bar

343-810100R90

SH 32

48-111142L IC 80 bar

343-810100L90



Ø 25

**Boring bar holder, double, 24 station**  
48-87678

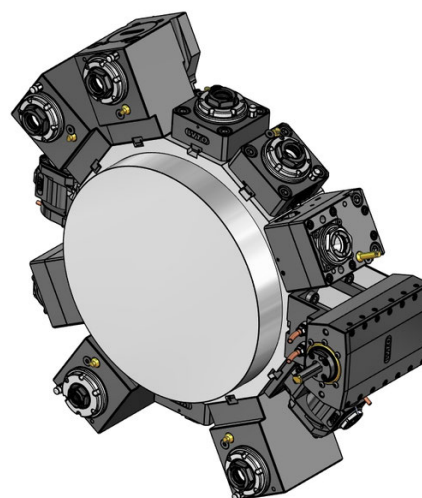
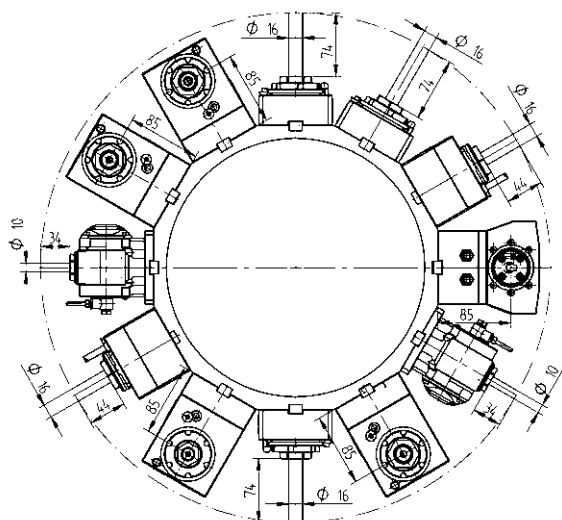

Driven Toolholders - QuickFlex®



**Straight drill/milling unit**

- ER-25 QF** 420125015-55 1:1 EC  
0067725000
- ER-25 QF** 420125016-55 1:1 IC 80 bar  
0067725000



**Right angle drill/milling unit, LF=85**

- ER-25 QF** 420525018-55 1:1 EC  
0067725000
- ER-25 QF** 420525019-55 1:1 IC 80 bar  
0067725000



**Right angle drill/milling unit, both sides, LF=85**

- ER-25 QF** 420525020-55 1:1 EC  
0067725000

Driven Toolholders - Enhanced Program



**Straight drill/milling unit**

- ER 32** 410120010-55 1:1 EC  
0067725000
- ER 32** 410120011-55 1:1 IC 80 bar  
0067725000



**Straight milling unit with combination mill arbor DIN 6358**

- Ø 22** 410222004-55 1:1 EC  
00675000483
- Ø 3/4"** 410219002-55 1:1 EC  
00675000483



**Straight offset drill/milling unit**

- ER 25** 410116029-55 1:1 EC  
00675000932
- ER 25** 410116030-55 1:1 IC 80 bar  
00675000932
- ER 20** 410113009-55 1:2 EC  
00675000939
- ER 20** 410113010-55 1:2 IC 80 bar  
00675000939
- ER 16** 410410004-55 1:3 EC  
00675000937
- ER 16** 410410005-55 1:3 IC 80 bar  
00675000937



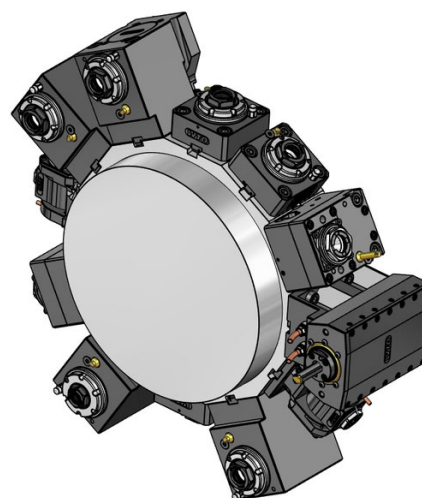
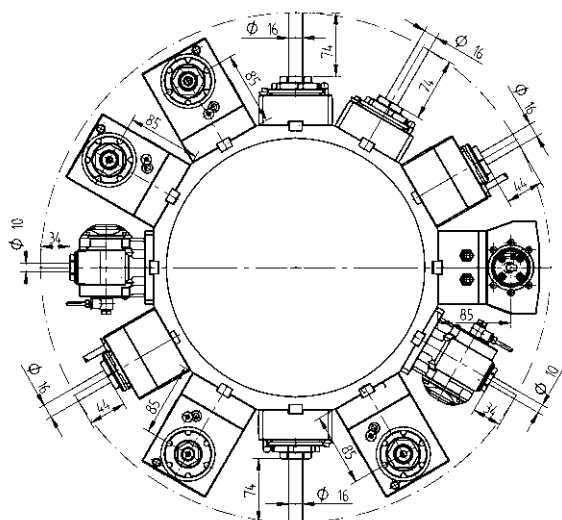

Driven Toolholders - Enhanced Program



**Right angle drill/milling unit, LF=85**

<b>ER 32</b>	410520030-55 0067725000	1:1	EC
<b>ER 32</b>	410520031-55 0067725000	1:1	IC 80 bar
<b>ER-20 QF</b>	420520014-55 0067720001	1:2	EC
<b>ER-20 QF</b>	420520015-55 0067720001	1:2	IC 80 bar
<b>ER 16</b>	410810020-55 00675000841	1:3	EC
<b>ER 16</b>	410810021-55 00675000841	1:3	IC 80 bar
<b>ER-25 QF</b>	420525032-55 0067725000	2:1	EC
<b>ER-25 QF</b>	420525033-55 0067725000	2:1	IC 80 bar



**Right angle milling unit with combination mill arbor DIN 6358, LF=85**

<b>Ø 22</b>	410622011-55 00675000483	1:1	EC
<b>Ø 3/4"</b>	410619006-55 00675000483	1:1	EC

Driven Toolholders - Enhanced Program



**Adjustable angle drill/milling unit**

<b>ER 16</b>	411010005-55 00675000902	1:1	EC
<b>ER 16</b>	411010006-55 00675000902	1:1	IC 80 bar
<b>ER 11</b>	411007007-55 00675000914	1:2	EC
<b>ER 11</b>	411007008-55 00675000914	1:2	IC 80 bar

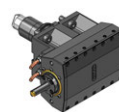

**Broaching unit for ID and OD**

<b>Type 32</b>	414532000-55	1:1	EC
----------------	--------------	-----	----

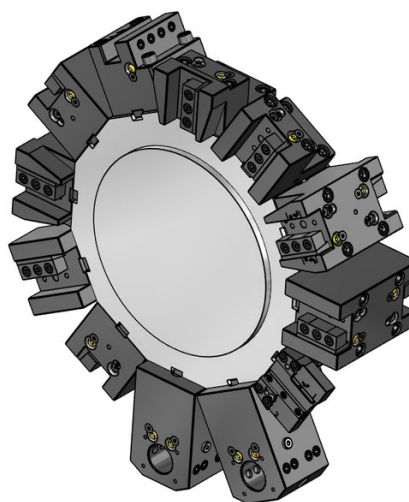
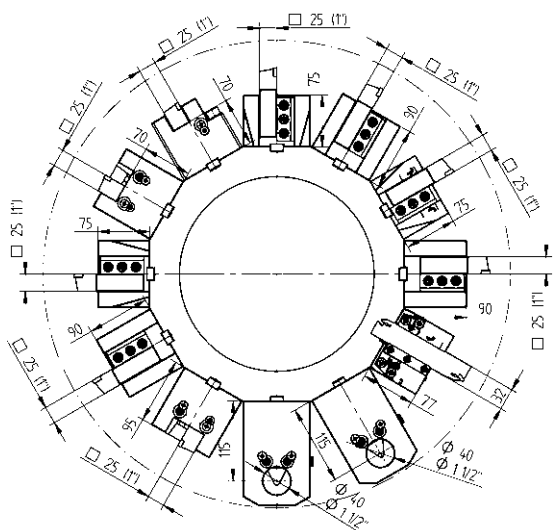

Static Toolholders - Standard Program

Static Toolholders - Standard Program



25  
1"

**OD cutting holder**

48-92428  
48-92466



25  
1"

**OD cutting holder, HP-IC**

48-92428-HP      IC 80 bar  
48-92466-HP      IC 80 bar



25  
1"

**OD cutting holder, long**

48-86711  
48-86712



25  
1"

**OD cutting holder, both sides**

48-92438  
48-92472



25  
1"

**OD cutting holder, both sides, HP-IC**

48-92438-HP      IC 80 bar  
48-92472-HP      IC 80 bar

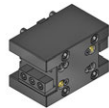

25  
1"

**OD cutting holder, both sides, long**

48-84523  
48-86718



25  
1"

**Face cutting holder**

48-86719  
48-86720



25  
1"

**Face cutting holder, HP-IC**

48-109249-HP      IC 80 bar  
48-109250-HP      IC 80 bar



Ø 40

**Combination toolholder, LF=115**

48-86623      IC 80 bar

 241140020 ER32

 241140026 ER40

Ø 1 1/2"

48-86624      IC 80 bar

 2411150020 ER32



48-87089

**Cover plate**

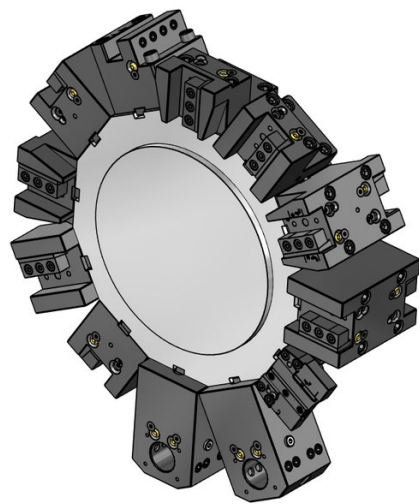
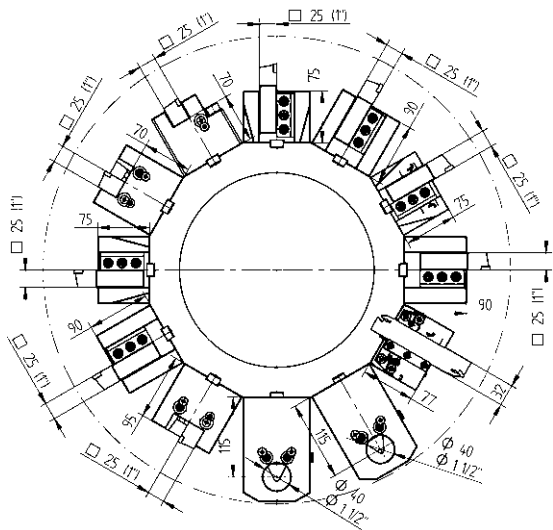

Static Toolholders - Enhanced Program



**Cut-off holder, adjustable**  
SH 32 48-99060



**Cut-off holder, adjustable, long**  
SH 32 48-100084



**Cut-off holder, adjustable, HP-IC**  
SH 32 48-102256R IC 80 bar  
SH 32 48-102256L IC 80 bar



**Cut-off holder, adjustable, long, HP-IC**  
SH 32 48-100082R IC 80 bar  
SH 32 48-100082L IC 80 bar

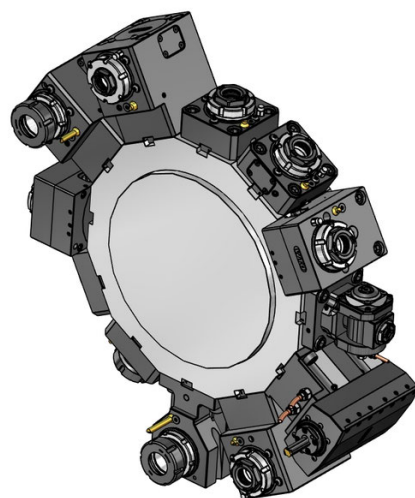
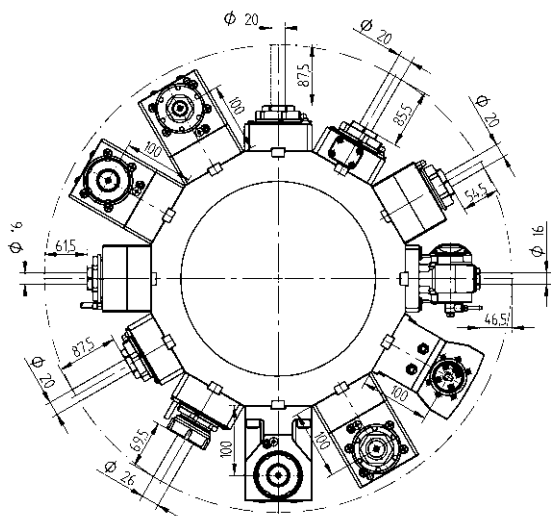

Driven Toolholders - QuickFlex®



**Straight drill/milling unit**

**ER-32 QF** QF32-DNE-BT65A-058-E-A 1:1 EC  
0067732000

**ER-32 QF** QF32-DNE-BT65A-060-I-A 1:1 IC 100 bar  
0067732000



**Straight drill/milling unit - QF smart (EU, US, CA, JP)**

**ER-32 QF** QF32-DNE-BT65A-060-I-SB-A 1:1 IC 100 bar  
0067732000

LI-F12-01



**Right angle drill/milling unit, LF=100**

**ER-32 QF** 420532018-65 1:1 EC  
0067732000

**ER-32 QF** QF32-DNI-BT65A-100-I-A 1:1 IC 100 bar  
0067732000



**Right angle drill/milling unit - QF smart (EU, US, CA, JP), LF=100**

**ER-32 QF** QF32-DNI-BT65A-100-I-SB-A 1:1 IC 100 bar  
0067732000

LI-F12-01



**Right angle drill/milling unit, both sides, LF=100**

**ER-32 QF** 420532020-65 1:1 EC  
0067732000

Driven Toolholders - Enhanced Program



**Straight drill/milling unit**

**ER 40** ER40-DNE-BT65A-084-E-A 1:1 EC  
00675000079

**ER 40** ER40-DNE-BT65A-086-I-A 1:1 IC 100 bar  
00675000079



**Straight offset drill/milling unit**

**ER-32 QF** 420132037-65 1:1 EC  
0067732000

**ER-32 QF** 420132038-65 1:1 IC 80 bar  
0067732000

**ER-25 QF** 420125010-65 1:2 EC  
0067725001

**ER-25 QF** 420125011-65 1:2 IC 80 bar  
0067725001



**Right angle drill/milling unit, LF=100**

**ER 40** 410526007-65 1:1 EC  
00675000079

**ER 40** 410526008-65 1:1 IC 80 bar  
00675000079

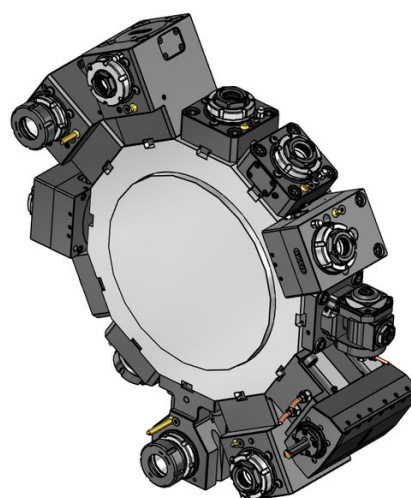
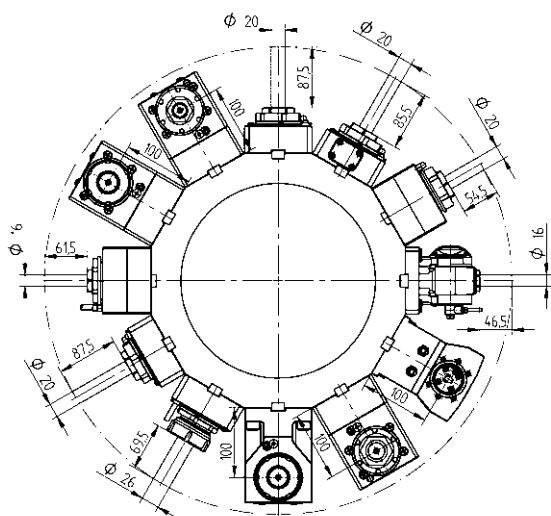

Driven Toolholders - Enhanced Program

Driven Toolholders - Enhanced Program



**Right angle drill/milling unit, LF=100**

<b>ER-25 QF</b>	QF25-DNI-BT65A-100-E-S-A 0067725001	1:2	EC
<b>ER-25 QF</b>	QF25-DNI-BT65A-100-I-S-A 0067725001	1:2	IC 100 bar
<b>ER-32 QF</b>	QF32-DNI-BT65A-100-E-T-A 0067732000	2:1	EC
<b>ER-32 QF</b>	QF32-DNI-BT65A-100-I-T-A 0067732000	2:1	IC 100 bar

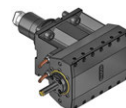

**Broaching unit for ID and OD**

<b>Type 32</b>	414532000-65	1:1	EC
----------------	--------------	-----	----



**Right angle back set drill/milling unit**

<b>ER-32 QF</b>	420532090-65 0067732000	1:1	EC
<b>ER-32 QF</b>	420532091-65 0067732000	1:1	IC 80 bar



**Adjustable angle drill/milling unit**

<b>ER 16</b>	411010002-65 00675000902	1:1	EC
<b>ER 16</b>	411010003-65 00675000902	1:1	IC 80 bar
<b>ER 11</b>	411007002-65 00675000914	1:2	EC
<b>ER 11</b>	411007003-65 00675000914	1:2	IC 80 bar



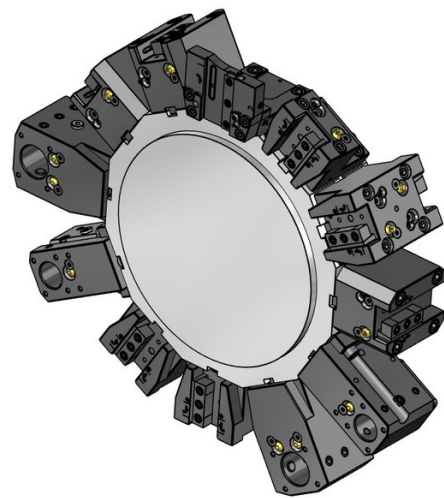
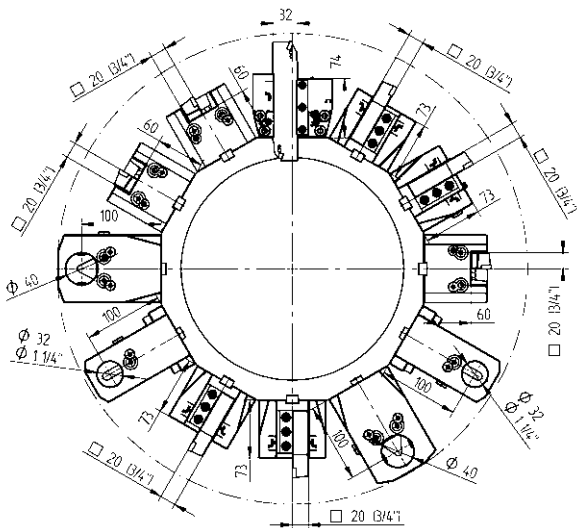

Static Toolholders - Standard Program



**OD cutting holder**  
 20 48-92036  
 3/4" 48-92037



**OD cutting holder, HP-IC**  
 20 48-92036-HP IC 80 bar  
 3/4" 48-92037-HP IC 80 bar



**OD cutting holder, both sides**  
 20 48-92038  
 3/4" 48-92039



**OD cutting holder, both sides, HP-IC**  
 20 48-92038-HP IC 80 bar  
 3/4" 48-92039-HP IC 80 bar



**Face cutting holder**  
 20 48-92045  
 3/4" 48-92046



**Face cutting holder, HP-IC**  
 20 48-92045-HP IC 80 bar  
 3/4" 48-92046-HP IC 80 bar

Static Toolholders - Standard Program



**Combination toolholder, universal, LF=100**  
 $\phi 32$  48-92043 IC 80 bar



241132016 ER25



241132020 ER32

$\phi 1 \frac{1}{4}$ " 48-92044 IC 80 bar



2411125020 ER32



**Combination toolholder, universal, LF=100**  
 $\phi 40$  48-103474 IC 80 bar



241140020 ER32



241140026 ER40

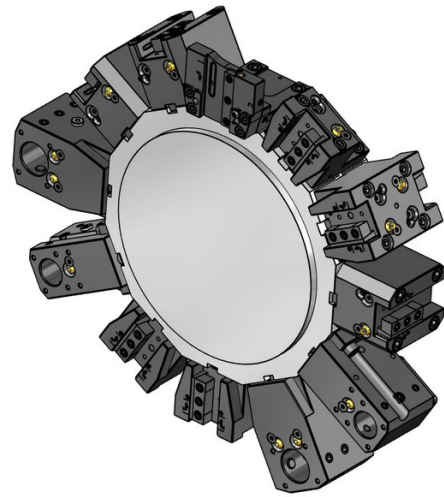
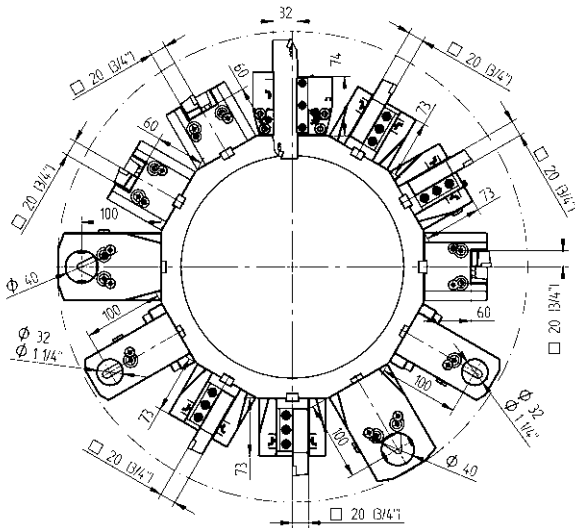

Static Toolholders - Enhanced Program



SH 32

**Cut-off holder, adjustable**

48-103287



SH 32

**Cut-off holder, adjustable, HP-IC**

SH 32

48-110160R

IC 80 bar

48-110160L

IC 80 bar



SH 32

**Cut-off holder, adjustable, long**

48-103288



SH 32

**Cut-off holder, adjustable, long, HP-IC**

SH 32

48-111142R

IC 80 bar

343-810100R90

SH 32

48-111142L

IC 80 bar

343-810100L90

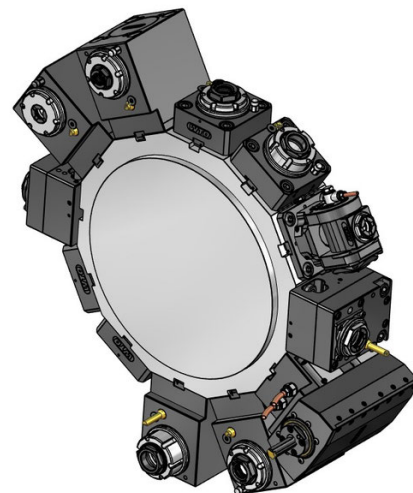
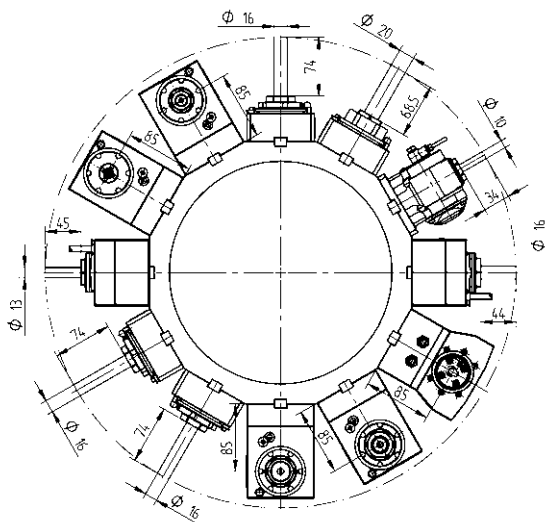

### Driven Toolholders - QuickFlex®



**Straight drill/milling unit**

- |                 |                            |     |           |
|-----------------|----------------------------|-----|-----------|
| <b>ER-25 QF</b> | 420125015-55<br>0067725000 | 1:1 | EC        |
| <b>ER-25 QF</b> | 420125016-55<br>0067725000 | 1:1 | IC 80 bar |



**Right angle drill/milling unit, LF=85**

- |                 |                            |     |           |
|-----------------|----------------------------|-----|-----------|
| <b>ER-25 QF</b> | 420525018-55<br>0067725000 | 1:1 | EC        |
| <b>ER-25 QF</b> | 420525019-55<br>0067725000 | 1:1 | IC 80 bar |



**Right angle drill/milling unit, both sides, LF=85**

- |                 |                            |     |    |
|-----------------|----------------------------|-----|----|
| <b>ER-25 QF</b> | 420525020-55<br>0067725000 | 1:1 | EC |
|-----------------|----------------------------|-----|----|

### Driven Toolholders - Enhanced Program



**Straight drill/milling unit**

- |              |                            |     |           |
|--------------|----------------------------|-----|-----------|
| <b>ER 32</b> | 410120010-55<br>0067725000 | 1:1 | EC        |
| <b>ER 32</b> | 410120011-55<br>0067725000 | 1:1 | IC 80 bar |



**Straight offset drill/milling unit**

- |              |                             |     |           |
|--------------|-----------------------------|-----|-----------|
| <b>ER 25</b> | 410116029-55<br>00675000932 | 1:1 | EC        |
| <b>ER 25</b> | 410116030-55<br>00675000932 | 1:1 | IC 80 bar |
| <b>ER 20</b> | 410113009-55<br>00675000939 | 1:2 | EC        |
| <b>ER 20</b> | 410113010-55<br>00675000939 | 1:2 | IC 80 bar |
| <b>ER 16</b> | 410410004-55<br>00675000937 | 1:3 | EC        |
| <b>ER 16</b> | 410410005-55<br>00675000937 | 1:3 | IC 80 bar |

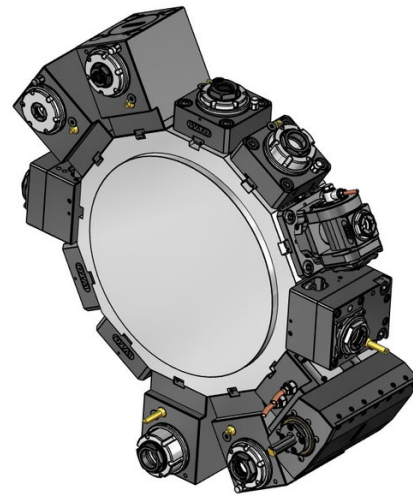
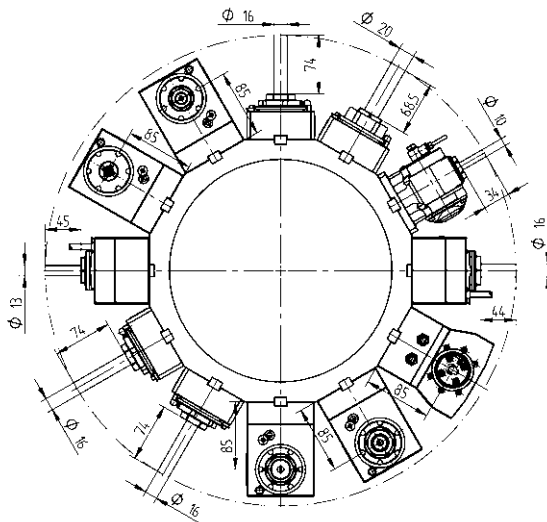

Driven Toolholders - Enhanced Program

Driven Toolholders - Enhanced Program



**Right angle drill/milling unit, LF=85**

<b>ER 32</b>	410520030-55 0067725000	1:1	EC
<b>ER 32</b>	410520031-55 0067725000	1:1	IC 80 bar
<b>ER-20 QF</b>	420520014-55 0067720001	1:2	EC
<b>ER-20 QF</b>	420520015-55 0067720001	1:2	IC 80 bar
<b>ER 16</b>	410810020-55 00675000841	1:3	EC
<b>ER 16</b>	410810021-55 00675000841	1:3	IC 80 bar
<b>ER-25 QF</b>	420525032-55 0067725000	2:1	EC
<b>ER-25 QF</b>	420525033-55 0067725000	2:1	IC 80 bar



**Adjustable angle drill/milling unit**

<b>ER 16</b>	411010005-55 00675000902	1:1	EC
<b>ER 16</b>	411010006-55 00675000902	1:1	IC 80 bar
<b>ER 11</b>	411007007-55 00675000914	1:2	EC
<b>ER 11</b>	411007008-55 00675000914	1:2	IC 80 bar



**Right angle milling unit with combination mill arbor DIN 6358, LF=85**

<b>Ø 22</b>	410622011-55 00675000483	1:1	EC
<b>Ø 3/4"</b>	410619006-55 00675000483	1:1	EC

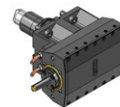

**Broaching unit for ID and OD**

<b>Type 32</b>	414532000-55	1:1	EC
----------------	--------------	-----	----

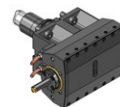

**Broaching unit for ID and OD**

<b>Type 52</b>	414552002-55	1:1	EC
----------------	--------------	-----	----

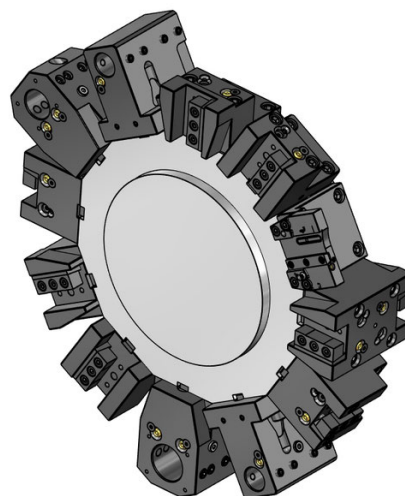
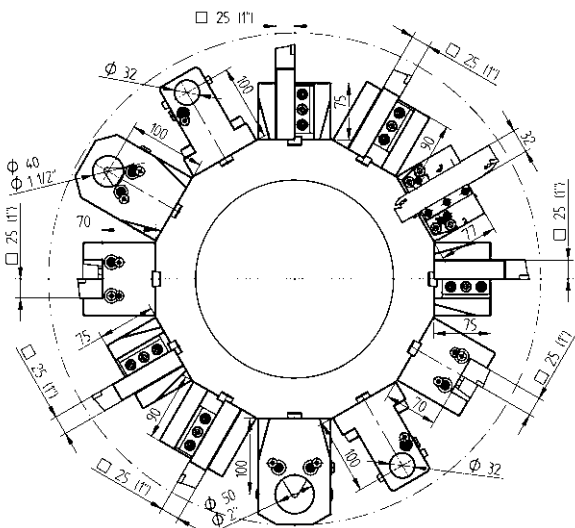

Static Toolholders - Standard Program

Static Toolholders - Standard Program



25  
1"

**OD cutting holder**

48-92428  
48-92466



25  
1"

**OD cutting holder, HP-IC**

48-92428-HP IC 80 bar  
48-92466-HP IC 80 bar



25  
1"

**OD cutting holder, long**

48-86711  
48-86712



25  
1"

**OD cutting holder, both sides**

48-92438  
48-92472



25  
1"

**OD cutting holder, both sides, HP-IC**

48-92438-HP IC 80 bar  
48-92472-HP IC 80 bar



25  
1"

**OD cutting holder, both sides, long**

48-84523  
48-86718



25  
1"

**Face cutting holder**

48-86719  
48-86720



25  
1"

**Face cutting holder, HP-IC**

48-109249-HP IC 80 bar  
48-109250-HP IC 80 bar



Ø 40

**Combination toolholder, LF=100**

48-92397 IC 80 bar  
241140020 ER32  
241140026 ER40

Ø 50

48-92467 IC 80 bar

Ø 1 1/2"

48-92468 IC 80 bar

2411150020 ER32

Ø 2"

48-92469 IC 80 bar



Ø 32

**Boring bar holder, both sides**

48-101033

Ø 1 1/4"

48-113514



48-87089

**Cover plate**



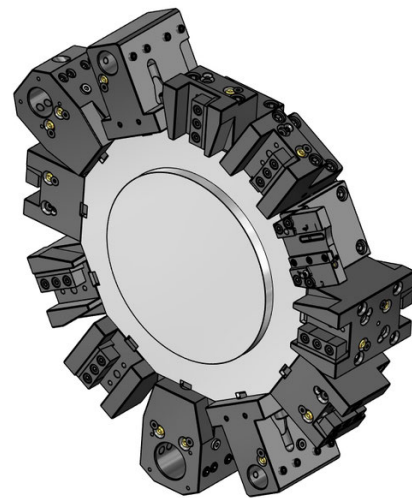
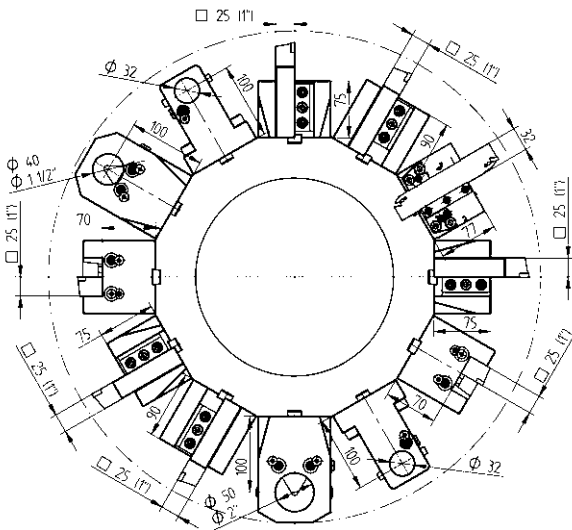

Static Toolholders - Enhanced Program



**SH 32** Cut-off holder, adjustable  
48-99060



**SH 32** Cut-off holder, adjustable, long  
48-100084



**SH 32** Cut-off holder, adjustable, HP-IC  
48-102256R IC 80 bar  
**SH 32** 48-102256L IC 80 bar



**SH 32** Cut-off holder, adjustable, long, HP-IC  
48-100082R IC 80 bar  
**SH 32** 48-100082L IC 80 bar



**Ø 50** Boring bar holder, with slot, LF=100  
48-119005 EC

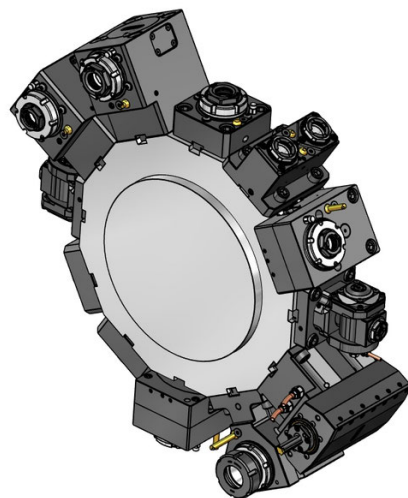
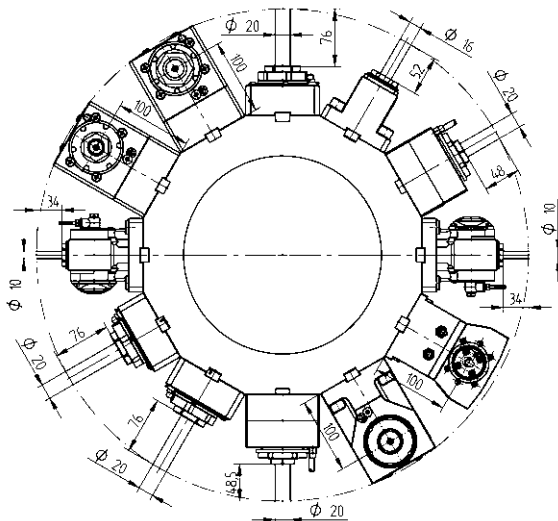

Driven Toolholders - QuickFlex®



**Straight drill/milling unit**

**ER-32 QF** QF32-DNE-BT65A-058-E-A 1:1 EC  
 0067732000

**ER-32 QF** QF32-DNE-BT65A-060-I-A 1:1 IC 100 bar  
 0067732000



**Straight drill/milling unit - QF smart (EU, US, CA, JP)**

**ER-32 QF** QF32-DNE-BT65A-060-I-SB-A 1:1 IC 100 bar  
 0067732000

LI-F12-01



**Right angle drill/milling unit, LF=100**

**ER-32 QF** 420532018-65 1:1 EC  
 0067732000

**ER-32 QF** QF32-DNI-BT65A-100-I-A 1:1 IC 100 bar  
 0067732000



**Right angle drill/milling unit - QF smart (EU, US, CA, JP), LF=100**

**ER-32 QF** QF32-DNI-BT65A-100-I-SB-A 1:1 IC 100 bar  
 0067732000

LI-F12-01



**Right angle drill/milling unit, both sides, LF=100**

**ER-32 QF** 420532020-65 1:1 EC  
 0067732000

Driven Toolholders - Enhanced Program



**Straight drill/milling unit**

**ER 40** ER40-DNE-BT65A-084-E-A 1:1 EC  
 00675000079

**ER 40** ER40-DNE-BT65A-086-I-A 1:1 IC 100 bar  
 00675000079



**Straight offset drill/milling unit**

**ER-32 QF** 420132037-65 1:1 EC  
 0067732000

**ER-32 QF** 420132038-65 1:1 IC 80 bar  
 0067732000

**ER-25 QF** 420125010-65 1:2 EC  
 0067725001

**ER-25 QF** 420125011-65 1:2 IC 80 bar  
 0067725001



**Right angle drill/milling unit, LF=100**

**ER 40** 410526007-65 1:1 EC  
 00675000079

**ER 40** 410526008-65 1:1 IC 80 bar  
 00675000079

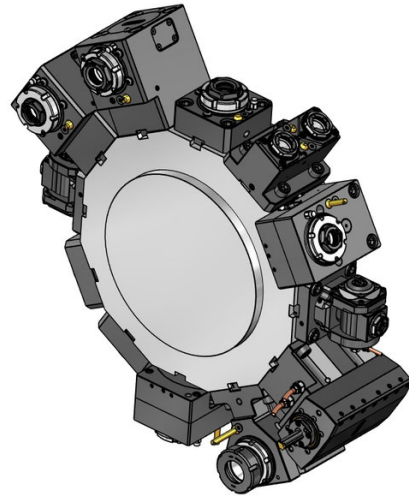
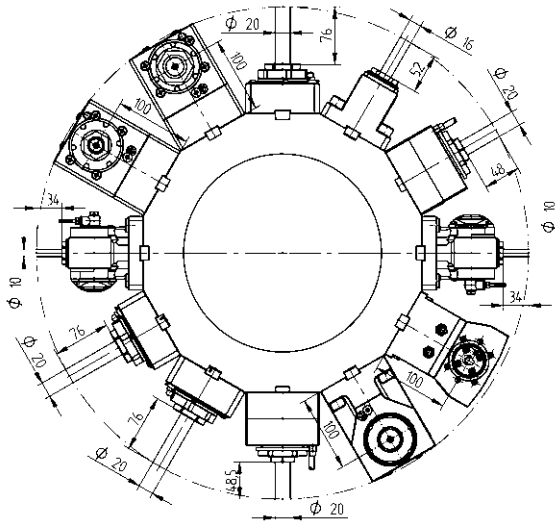

Driven Toolholders - Enhanced Program



**Right angle drill/milling unit, LF=100**

- |                 |                          |     |            |
|-----------------|--------------------------|-----|------------|
| <b>ER-25 QF</b> | QF25-DNI-BT65A-100-E-S-A | 1:2 | EC         |
|                 | 0067725001               |     |            |
| <b>ER-25 QF</b> | QF25-DNI-BT65A-100-I-S-A | 1:2 | IC 100 bar |
|                 | 0067725001               |     |            |
| <b>ER-32 QF</b> | QF32-DNI-BT65A-100-E-T-A | 2:1 | EC         |
|                 | 0067732000               |     |            |
| <b>ER-32 QF</b> | QF32-DNI-BT65A-100-I-T-A | 2:1 | IC 100 bar |
|                 | 0067732000               |     |            |



**Right angle back set drill/milling unit**

- |                 |              |     |           |
|-----------------|--------------|-----|-----------|
| <b>ER-32 QF</b> | 420532090-65 | 1:1 | EC        |
|                 | 0067732000   |     |           |
| <b>ER-32 QF</b> | 420532091-65 | 1:1 | IC 80 bar |
|                 | 0067732000   |     |           |



**Adjustable angle drill/milling unit**

- |              |              |     |           |
|--------------|--------------|-----|-----------|
| <b>ER 16</b> | 411010002-65 | 1:1 | EC        |
|              | 00675000902  |     |           |
| <b>ER 16</b> | 411010003-65 | 1:1 | IC 80 bar |
|              | 00675000902  |     |           |
| <b>ER 11</b> | 411007002-65 | 1:2 | EC        |
|              | 00675000914  |     |           |
| <b>ER 11</b> | 411007003-65 | 1:2 | IC 80 bar |
|              | 00675000914  |     |           |

Driven Toolholders - Enhanced Program



**Straight drill/milling unit, both sides**

- |              |              |     |    |
|--------------|--------------|-----|----|
| <b>ER 25</b> | 413002005-65 | 1:1 | EC |
|              | 00675000907  |     |    |

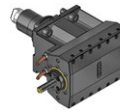

**Broaching unit for ID and OD**

- |                |              |     |    |
|----------------|--------------|-----|----|
| <b>Type 32</b> | 414532000-65 | 1:1 | EC |
|----------------|--------------|-----|----|



**Broaching unit for ID and OD**

- |                |              |     |    |
|----------------|--------------|-----|----|
| <b>Type 52</b> | 414552000-65 | 1:1 | EC |
|----------------|--------------|-----|----|

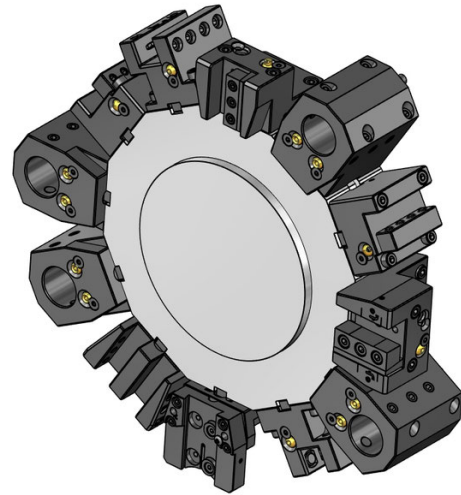
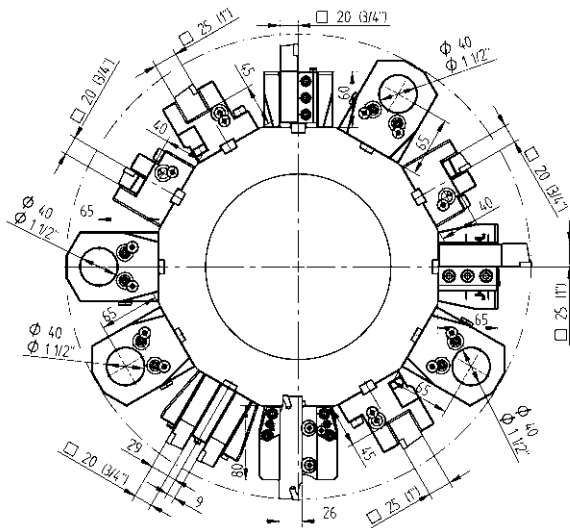

Static Toolholders - Standard Program

Static Toolholders - Standard Program



20  
3/4"

**OD cutting holder**

48-95083  
48-95084



20  
3/4"

**OD cutting holder, HP-IC**

48-100605-HP IC 80 bar  
48-108926-HP IC 80 bar



25  
1"

**OD cutting holder, HP-IC**

48-104395-HP IC 80 bar  
48-104396-HP IC 80 bar



20  
3/4"

**OD cutting holder, both sides**

48-95085  
48-95086



20  
3/4"

**OD cutting holder, both sides, HP-IC**

48-95085-HP IC 80 bar  
48-95086-HP IC 80 bar



20 (3/4")

**OD cutting holder, both sides, double, Y axis**

48-110811



20

**Face cutting holder**

48-109148



3/4"

**Face cutting holder**

48-95338



20  
3/4"

**Face cutting holder, HP-IC**

48-109148-HP IC 80 bar  
48-109149-HP IC 80 bar



25  
1"

**Face cutting holder, HP-IC**

48-104397-HP IC 80 bar  
48-104398-HP IC 80 bar



SH 26

**Cut-off holder, adjustable**

48-94968



SH 26  
SH 26

**Cut-off holder, adjustable, HP-IC**

48-102252R IC 80 bar  
48-102252L IC 80 bar



Ø 40  
Ø 1 1/2"

**Combination toolholder, LF=65**

48-95090 IC 80 bar  
48-95327 IC 80 bar

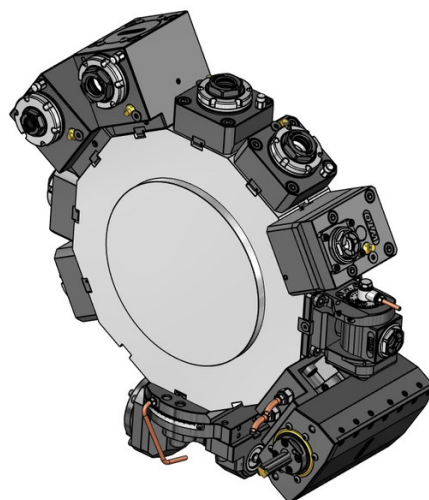
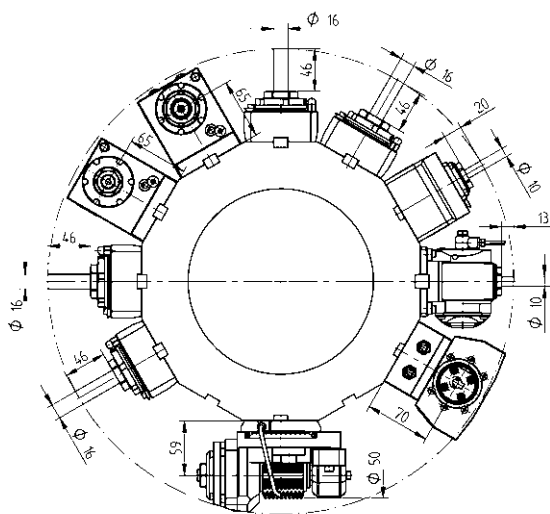

Driven Toolholders - QuickFlex®



- Straight drill/milling unit**
- |                 |              |     |           |
|-----------------|--------------|-----|-----------|
| <b>ER-25 QF</b> | 420125015-45 | 1:1 | EC        |
|                 | 0067725000   |     |           |
| <b>ER-25 QF</b> | 420125016-45 | 1:1 | IC 80 bar |
|                 | 0067725000   |     |           |



- Straight drill/milling unit (12000 RPM)**
- |                 |              |     |            |
|-----------------|--------------|-----|------------|
| <b>ER-25 QF</b> | 430125019-45 | 1:1 | EC         |
|                 | 0067725000   |     |            |
| <b>ER-25 QF</b> | 430125020-45 | 1:1 | IC 100 bar |
|                 | 0067725000   |     |            |



- Right angle drill/milling unit, LF=65**
- |                 |              |     |           |
|-----------------|--------------|-----|-----------|
| <b>ER-25 QF</b> | 420525015-45 | 1:1 | EC        |
|                 | 0067725000   |     |           |
| <b>ER-25 QF</b> | 420525016-45 | 1:1 | IC 80 bar |
|                 | 0067725000   |     |           |



- Right angle drill/milling unit (12000 RPM)**
- |                 |              |     |           |
|-----------------|--------------|-----|-----------|
| <b>ER-25 QF</b> | 420525054-45 | 1:1 | EC        |
|                 | 0067725000   |     |           |
| <b>ER-25 QF</b> | 420525055-45 | 1:1 | IC 80 bar |
|                 | 0067725000   |     |           |

Driven Toolholders - Enhanced Program



- Straight offset drill/milling unit**
- |              |              |     |           |
|--------------|--------------|-----|-----------|
| <b>ER 16</b> | 410410008-45 | 1:3 | EC        |
|              | 00675000937  |     |           |
| <b>ER 16</b> | 410410002-45 | 1:3 | IC 80 bar |
|              | 00675000937  |     |           |



- Right angle drill/milling unit, LF=65**
- |                 |              |     |           |
|-----------------|--------------|-----|-----------|
| <b>ER-20 QF</b> | 420520018-45 | 1:2 | EC        |
|                 | 0067720001   |     |           |
| <b>ER-20 QF</b> | 420520019-45 | 1:2 | IC 80 bar |
|                 | 0067720001   |     |           |
| <b>ER-25 QF</b> | 420525020-45 | 2:1 | EC        |
|                 | 0067725000   |     |           |
| <b>ER-25 QF</b> | 420525021-45 | 2:1 | IC 80 bar |
|                 | 0067725000   |     |           |



- Adjustable angle drill/milling unit**
- |              |              |     |           |
|--------------|--------------|-----|-----------|
| <b>ER 16</b> | 411010008-45 | 1:1 | EC        |
|              | 00675000902  |     |           |
| <b>ER 16</b> | 411010009-45 | 1:1 | IC 80 bar |
|              | 00675000902  |     |           |
| <b>ER 11</b> | 411007004-45 | 1:2 | EC        |
|              | 00675000914  |     |           |
| <b>ER 11</b> | 411007005-45 | 1:2 | IC 80 bar |
|              | 00675000914  |     |           |



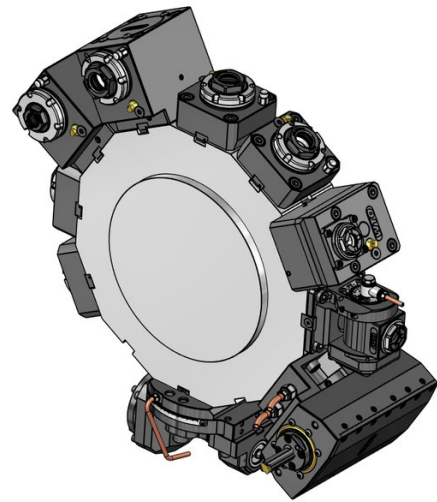
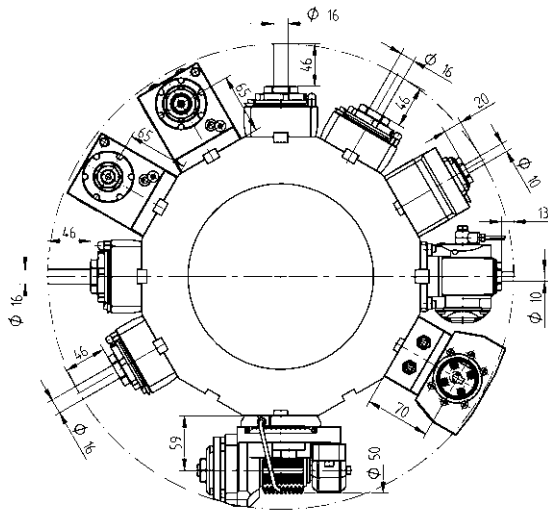

Driven Toolholders - Enhanced Program

Driven Toolholders - Enhanced Program



- Gear hobbing unit**
- |                  |                  |     |    |
|------------------|------------------|-----|----|
| <b>Type 15-2</b> | 410900003-45     | 1:1 | EC |
|                  | 00675001015      |     |    |
|                  | 160008152 Ø 8    |     |    |
|                  | 160010152 Ø 10   |     |    |
|                  | 160013152 Ø 13   |     |    |
|                  | 160016152 Ø 16   |     |    |
|                  | 160022152 Ø 22   |     |    |
|                  | 160015152 Ø 5/8" |     |    |
|                  | 160019152 Ø 3/4" |     |    |
|                  | 110587           |     |    |



- Broaching unit for ID and OD**
- |                |              |     |    |
|----------------|--------------|-----|----|
| <b>Type 32</b> | 414532005-45 | 1:1 | EC |
|----------------|--------------|-----|----|



- Straight drill/milling unit, double, Y axis**
- |              |              |     |           |
|--------------|--------------|-----|-----------|
| <b>ER 20</b> | 413002006-45 | 1:1 | EC        |
|              | 00675000947  |     |           |
| <b>ER 20</b> | 413002008-45 | 1:1 | IC 80 bar |
|              | 00675000947  |     |           |



- 2-spindle - Right angle drill/milling unit, Y axis**
- |              |              |     |           |
|--------------|--------------|-----|-----------|
| <b>ER 20</b> | 413502001-45 | 1:1 | EC        |
|              | 00675000939  |     |           |
| <b>ER 20</b> | 413502002-45 | 1:1 | IC 80 bar |
|              | 00675000939  |     |           |

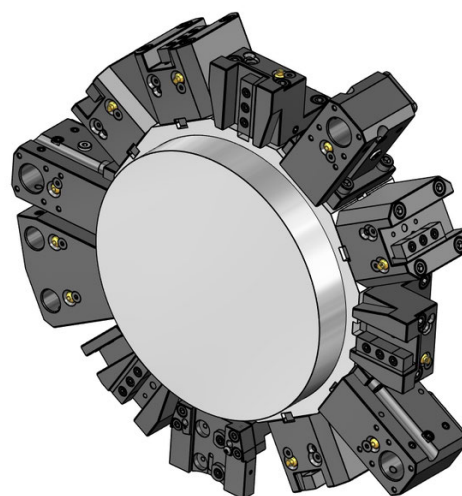
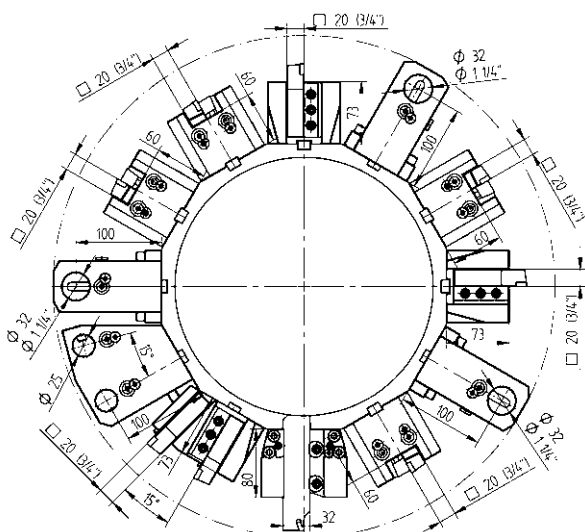

Static Toolholders - Standard Program

Static Toolholders - Standard Program



**OD cutting holder**  
 20 48-92036  
 3/4" 48-92037



**OD cutting holder, HP-IC**  
 20 48-92036-HP IC 80 bar  
 3/4" 48-92037-HP IC 80 bar



**OD cutting holder, both sides**  
 20 48-92038  
 3/4" 48-92039



**OD cutting holder, both sides, HP-IC**  
 20 48-92038-HP IC 80 bar  
 3/4" 48-92039-HP IC 80 bar



**Face cutting holder**  
 20 48-92045  
 3/4" 48-92046



**Face cutting holder, HP-IC**  
 20 48-92045-HP IC 80 bar  
 3/4" 48-92046-HP IC 80 bar



**Combination toolholder, universal, LF=100**  
 Ø 32 48-92043 IC 80 bar  
 241132016 ER25  
 241132020 ER32  
 Ø 1 1/4" 48-92044 IC 80 bar  
 2411125020 ER32

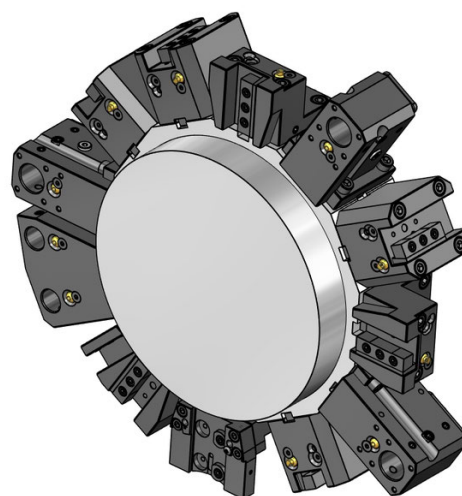
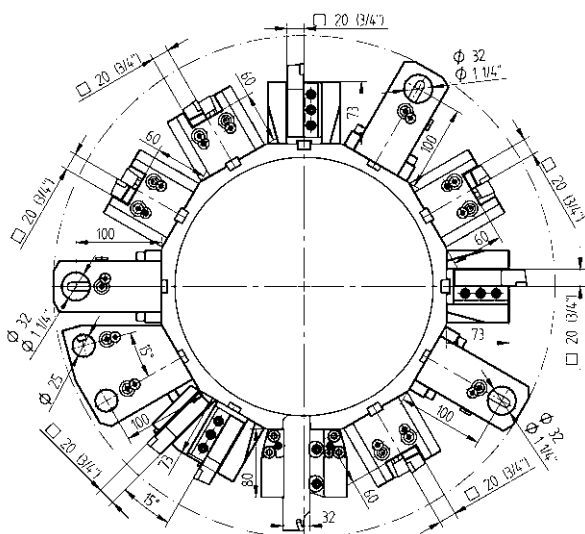

Static Toolholders - Enhanced Program



20

**OD cutting holder, double, 24 station**  
48-87674



20

**OD cutting holder, both sides, double, 24 station**  
48-92980



SH 32

**Cut-off holder, adjustable**  
48-103287



SH 32

**Cut-off holder, adjustable, HP-IC**

SH 32

48-110160R IC 80 bar  
48-110160L IC 80 bar



SH 32

**Cut-off holder, adjustable, long**  
48-103288



SH 32

**Cut-off holder, adjustable, long, HP-IC**

SH 32

48-111142R IC 80 bar  
343-810100R90

SH 32

48-111142L IC 80 bar  
343-810100L90



Ø 25

**Boring bar holder, double, 24 station**

48-87678

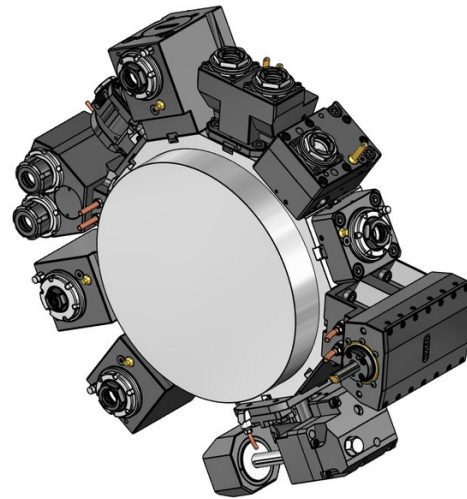
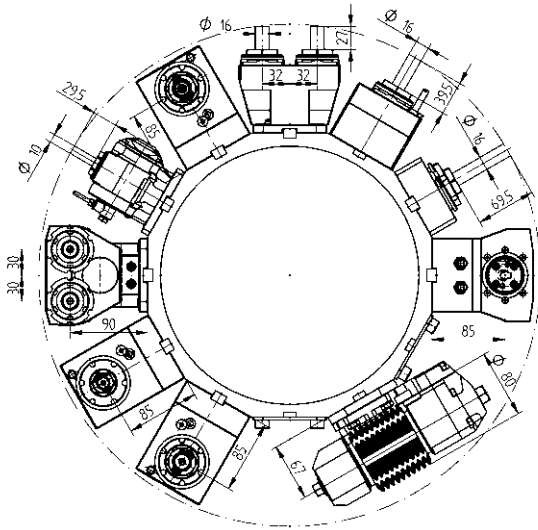

Driven Toolholders - QuickFlex®



**Straight drill/milling unit**

- ER-25 QF** 420125015-55 1:1 EC  
 0067725000
- ER-25 QF** 420125016-55 1:1 IC 80 bar  
 0067725000



**Right angle drill/milling unit, LF=85**

- ER-25 QF** 420525018-55 1:1 EC  
 0067725000
- ER-25 QF** 420525019-55 1:1 IC 80 bar  
 0067725000



**Right angle drill/milling unit, both sides, LF=85**

- ER-25 QF** 420525020-55 1:1 EC  
 0067725000

Driven Toolholders - Enhanced Program



**Straight drill/milling unit**

- ER 32** 410120010-55 1:1 EC  
 0067725000
- ER 32** 410120011-55 1:1 IC 80 bar  
 0067725000



**Straight milling unit with combination mill arbor DIN 6358**

- Ø 22** 410222004-55 1:1 EC  
 00675000483
- Ø 3/4"** 410219002-55 1:1 EC  
 00675000483

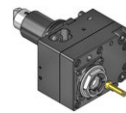

**Straight offset drill/milling unit**

- ER 25** 410116029-55 1:1 EC  
 00675000932
- ER 25** 410116030-55 1:1 IC 80 bar  
 00675000932
- ER 20** 410113009-55 1:2 EC  
 00675000939
- ER 20** 410113010-55 1:2 IC 80 bar  
 00675000939
- ER 16** 410410004-55 1:3 EC  
 00675000937
- ER 16** 410410005-55 1:3 IC 80 bar  
 00675000937

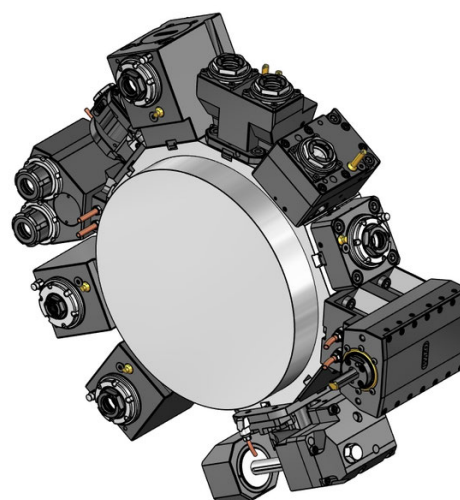
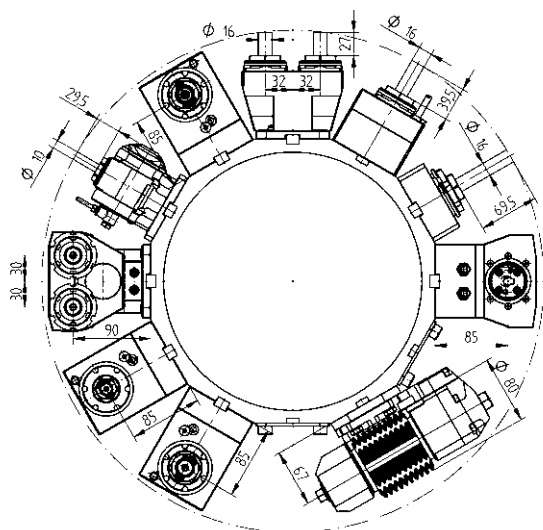

Driven Toolholders - Enhanced Program



**Right angle drill/milling unit, LF=85**

<b>ER 32</b>	410520030-55 0067725000	1:1	EC
<b>ER 32</b>	410520031-55 0067725000	1:1	IC 80 bar
<b>ER-20 QF</b>	420520014-55 0067720001	1:2	EC
<b>ER-20 QF</b>	420520015-55 0067720001	1:2	IC 80 bar
<b>ER 16</b>	410810020-55 00675000841	1:3	EC
<b>ER 16</b>	410810021-55 00675000841	1:3	IC 80 bar
<b>ER-25 QF</b>	420525032-55 0067725000	2:1	EC
<b>ER-25 QF</b>	420525033-55 0067725000	2:1	IC 80 bar



**Right angle milling unit with combination mill arbor DIN 6358, LF=85**

<b>Ø 22</b>	410622011-55 00675000483	1:1	EC
<b>Ø 3/4"</b>	410619006-55 00675000483	1:1	EC

Driven Toolholders - Enhanced Program



**Adjustable angle drill/milling unit**

<b>ER 16</b>	411010005-55 00675000902	1:1	EC
<b>ER 16</b>	411010006-55 00675000902	1:1	IC 80 bar
<b>ER 11</b>	411007007-55 00675000914	1:2	EC
<b>ER 11</b>	411007008-55 00675000914	1:2	IC 80 bar

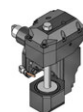

**Gear hobbing unit**

<b>Type 16-1</b>	411500002-55	1:1	EC
<b>Type 16-1</b>	411500001-55 00675000927	2:1	EC
	160016161 Ø 16		
	160022161 Ø 22		
	160027161 Ø 27		
	160015161 Ø 5/8"		
	160019161 Ø 3/4"		
	160025161 Ø 1"		
	160031161 Ø 1 1/4"		
	110587		



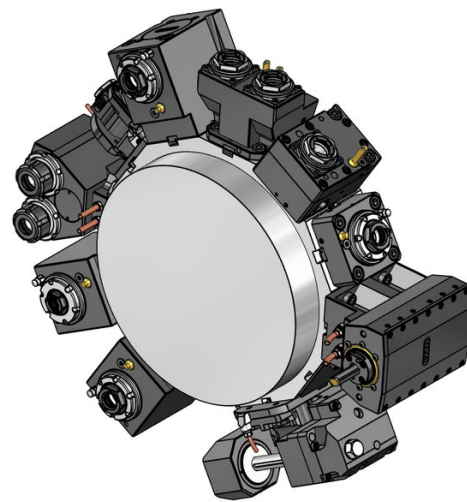
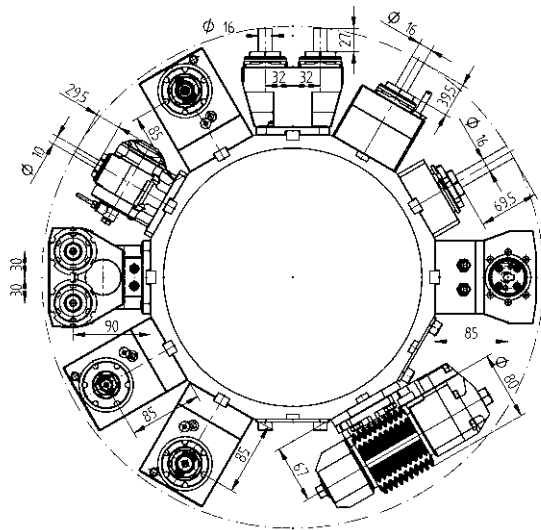

Driven Toolholders - Enhanced Program



- Straight drill/milling unit, double, Y axis**
- |              |              |     |           |
|--------------|--------------|-----|-----------|
| <b>ER 25</b> | 413002004-55 | 1:1 | EC        |
|              | 00675000970  |     |           |
| <b>ER 25</b> | 413002003-55 | 1:1 | IC 80 bar |
|              | 00675000970  |     |           |

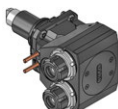

- 2-spindle - Right angle drill/milling unit, Y axis**
- |              |              |     |           |
|--------------|--------------|-----|-----------|
| <b>ER 25</b> | 413502007-55 | 1:1 | EC        |
|              | 00675000915  |     |           |
| <b>ER 25</b> | 413502008-55 | 1:1 | IC 80 bar |
|              | 00675000915  |     |           |



- 2-spindle - Right angle drill/milling unit, both sides, Y axis**
- |              |              |     |    |
|--------------|--------------|-----|----|
| <b>ER 25</b> | 413502006-55 | 1:1 | EC |
|              | 00675000915  |     |    |

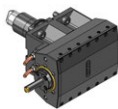

- Broaching unit for ID and OD**
- |                |              |     |    |
|----------------|--------------|-----|----|
| <b>Type 32</b> | 414532000-55 | 1:1 | EC |
|----------------|--------------|-----|----|

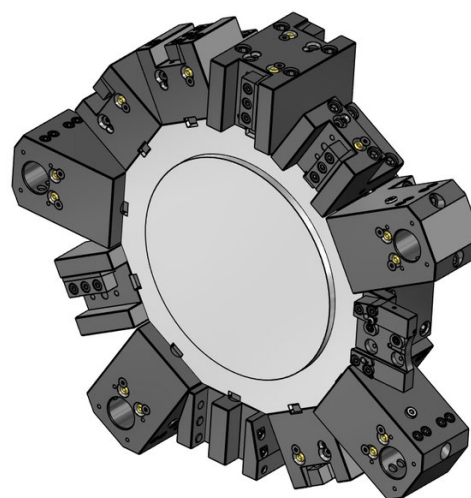
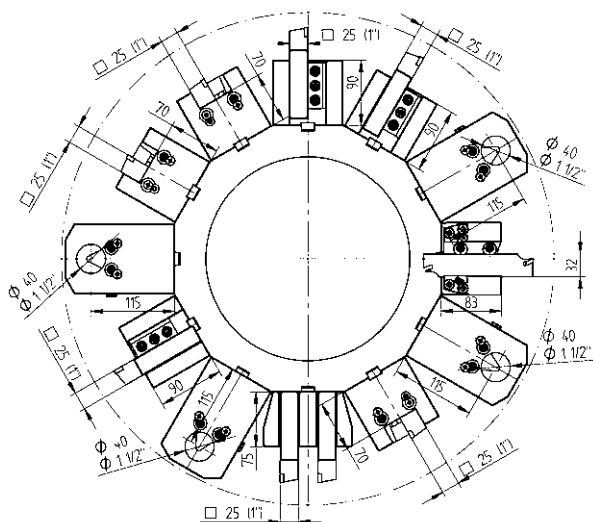

Static Toolholders - Standard Program

Static Toolholders - Standard Program



**OD cutting holder**  
 25 48-92428  
 1" 48-92466



**OD cutting holder, HP-IC**  
 25 48-92428-HP IC 80 bar  
 1" 48-92466-HP IC 80 bar



**OD cutting holder, long**  
 25 48-86711  
 1" 48-86712



**OD cutting holder, both sides**  
 25 48-92438  
 1" 48-92472



**OD cutting holder, both sides, HP-IC**  
 25 48-92438-HP IC 80 bar  
 1" 48-92472-HP IC 80 bar



**OD cutting holder, both sides, long**  
 25 48-84523  
 1" 48-86718



**Face cutting holder**  
 25 48-86719  
 1" 48-86720



**Face cutting holder, HP-IC**  
 25 48-109249-HP IC 80 bar  
 1" 48-109250-HP IC 80 bar



**Combination toolholder, LF=115**  
 Ø 40 48-86623 IC 80 bar  
 241140020 ER32  
 241140026 ER40  
 Ø 1 1/2" 48-86624 IC 80 bar  
 2411150020 ER32



**Cover plate**  
 48-87089

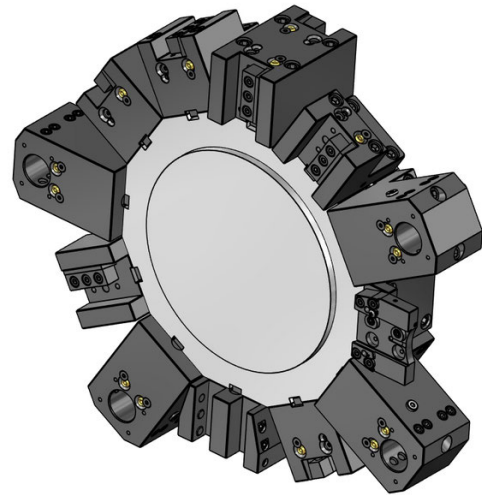
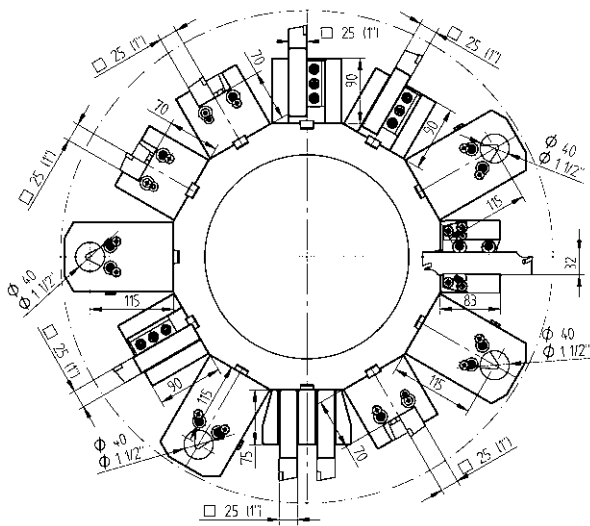

Static Toolholders - Enhanced Program



25(1")

**OD cutting holder, double, Y axis**

48-86103



25(1")

**OD cutting holder, both sides, double, Y axis**

48-86150



SH 32

**Cut-off holder, adjustable**

48-99060



SH 32

**Cut-off holder, adjustable, long**

48-100084



SH 32

**Cut-off holder, adjustable, HP-IC**

48-102256R

IC 80 bar

SH 32

48-102256L

IC 80 bar



SH 32

**Cut-off holder, adjustable, long, HP-IC**

48-100082R

IC 80 bar

SH 32

48-100082L

IC 80 bar

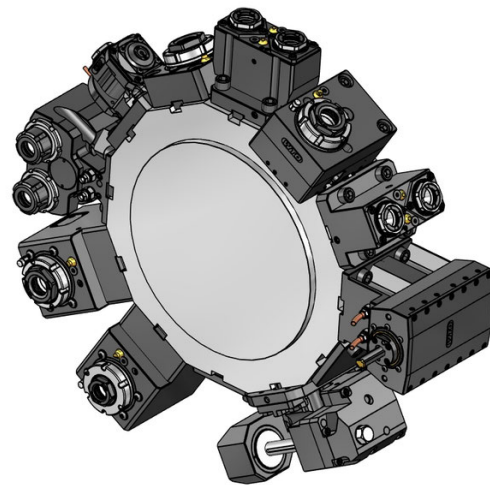
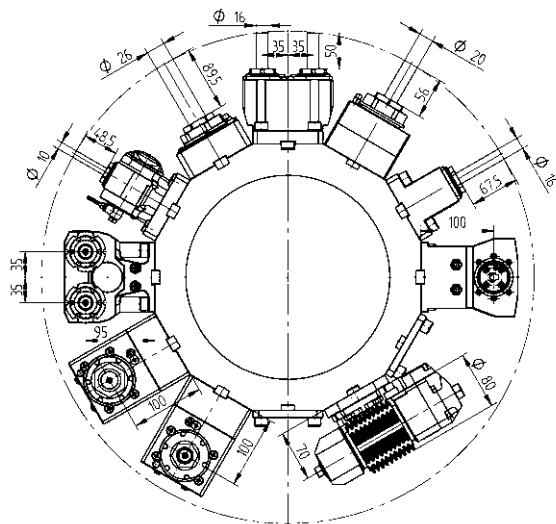

Driven Toolholders - QuickFlex®



- Straight drill/milling unit**
- |                 |                        |     |            |
|-----------------|------------------------|-----|------------|
| <b>ER-32 QF</b> | QF32-DNE-BT65A-058-E-A | 1:1 | EC         |
|                 | 0067732000             |     |            |
| <b>ER-32 QF</b> | QF32-DNE-BT65A-060-I-A | 1:1 | IC 100 bar |
|                 | 0067732000             |     |            |



- Straight drill/milling unit - QF smart (EU, US, CA, JP)**
- |                 |                           |     |            |
|-----------------|---------------------------|-----|------------|
| <b>ER-32 QF</b> | QF32-DNE-BT65A-060-I-SB-A | 1:1 | IC 100 bar |
|                 | 0067732000                |     |            |
|                 | LI-F12-01                 |     |            |



- Right angle drill/milling unit, LF=100**
- |                 |                        |     |            |
|-----------------|------------------------|-----|------------|
| <b>ER-32 QF</b> | 420532018-65           | 1:1 | EC         |
|                 | 0067732000             |     |            |
| <b>ER-32 QF</b> | QF32-DNI-BT65A-100-I-A | 1:1 | IC 100 bar |
|                 | 0067732000             |     |            |



- Right angle drill/milling unit - QF smart (EU, US, CA, JP), LF=100**
- |                 |                           |     |            |
|-----------------|---------------------------|-----|------------|
| <b>ER-32 QF</b> | QF32-DNI-BT65A-100-I-SB-A | 1:1 | IC 100 bar |
|                 | 0067732000                |     |            |
|                 | LI-F12-01                 |     |            |



- Right angle drill/milling unit, both sides, LF=100**
- |                 |              |     |    |
|-----------------|--------------|-----|----|
| <b>ER-32 QF</b> | 420532020-65 | 1:1 | EC |
|                 | 0067732000   |     |    |

Driven Toolholders - Enhanced Program



- Straight drill/milling unit**
- |              |                        |     |            |
|--------------|------------------------|-----|------------|
| <b>ER 40</b> | ER40-DNE-BT65A-084-E-A | 1:1 | EC         |
|              | 00675000079            |     |            |
| <b>ER 40</b> | ER40-DNE-BT65A-086-I-A | 1:1 | IC 100 bar |
|              | 00675000079            |     |            |



- Straight offset drill/milling unit**
- |                 |              |     |           |
|-----------------|--------------|-----|-----------|
| <b>ER-32 QF</b> | 420132037-65 | 1:1 | EC        |
|                 | 0067732000   |     |           |
| <b>ER-32 QF</b> | 420132038-65 | 1:1 | IC 80 bar |
|                 | 0067732000   |     |           |
| <b>ER-25 QF</b> | 420125010-65 | 1:2 | EC        |
|                 | 0067725001   |     |           |
| <b>ER-25 QF</b> | 420125011-65 | 1:2 | IC 80 bar |
|                 | 0067725001   |     |           |



- Right angle drill/milling unit, LF=100**
- |              |              |     |           |
|--------------|--------------|-----|-----------|
| <b>ER 40</b> | 410526007-65 | 1:1 | EC        |
|              | 00675000079  |     |           |
| <b>ER 40</b> | 410526008-65 | 1:1 | IC 80 bar |
|              | 00675000079  |     |           |

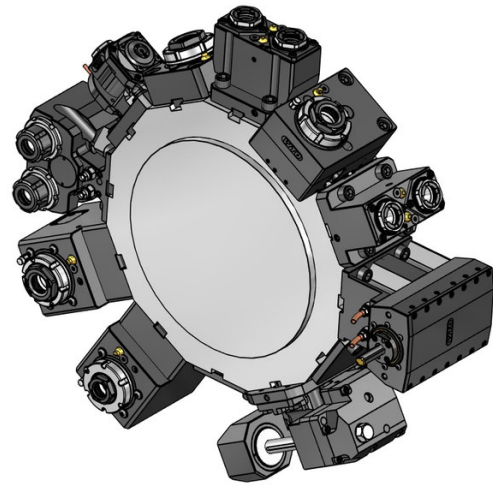
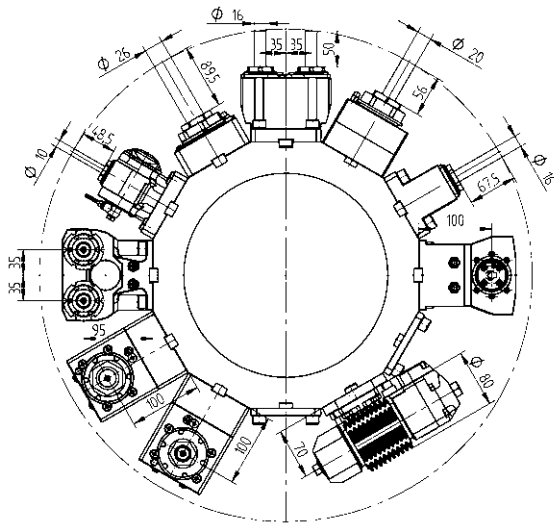

Driven Toolholders - Enhanced Program

Driven Toolholders - Enhanced Program



- Right angle drill/milling unit, LF=100**
- |                 |                          |     |            |
|-----------------|--------------------------|-----|------------|
| <b>ER-25 QF</b> | QF25-DNI-BT65A-100-E-S-A | 1:2 | EC         |
|                 | 0067725001               |     |            |
| <b>ER-25 QF</b> | QF25-DNI-BT65A-100-I-S-A | 1:2 | IC 100 bar |
|                 | 0067725001               |     |            |
| <b>ER-32 QF</b> | QF32-DNI-BT65A-100-E-T-A | 2:1 | EC         |
|                 | 0067732000               |     |            |
| <b>ER-32 QF</b> | QF32-DNI-BT65A-100-I-T-A | 2:1 | IC 100 bar |
|                 | 0067732000               |     |            |



- Right angle back set drill/milling unit**
- |                 |              |     |           |
|-----------------|--------------|-----|-----------|
| <b>ER-32 QF</b> | 420532090-65 | 1:1 | EC        |
|                 | 0067732000   |     |           |
| <b>ER-32 QF</b> | 420532091-65 | 1:1 | IC 80 bar |
|                 | 0067732000   |     |           |



- Adjustable angle drill/milling unit**
- |              |              |     |           |
|--------------|--------------|-----|-----------|
| <b>ER 16</b> | 411010002-65 | 1:1 | EC        |
|              | 00675000902  |     |           |
| <b>ER 16</b> | 411010003-65 | 1:1 | IC 80 bar |
|              | 00675000902  |     |           |
| <b>ER 11</b> | 411007002-65 | 1:2 | EC        |
|              | 00675000914  |     |           |
| <b>ER 11</b> | 411007003-65 | 1:2 | IC 80 bar |
|              | 00675000914  |     |           |



- Gear hobbing unit**
- |                  |                    |     |    |
|------------------|--------------------|-----|----|
| <b>Type 16-1</b> | 411500003-65       | 1:1 | EC |
| <b>Type 16-1</b> | 411500002-65       | 2:1 | EC |
|                  | 00675000927        |     |    |
|                  | 160016161 Ø 16     |     |    |
|                  | 160022161 Ø 22     |     |    |
|                  | 160027161 Ø 27     |     |    |
|                  | 160015161 Ø 5/8"   |     |    |
|                  | 160019161 Ø 3/4"   |     |    |
|                  | 160025161 Ø 1"     |     |    |
|                  | 160031161 Ø 1 1/4" |     |    |
|                  | 110587             |     |    |



- Straight drill/milling unit, both sides**
- |              |              |     |    |
|--------------|--------------|-----|----|
| <b>ER 25</b> | 413002005-65 | 1:1 | EC |
|              | 00675000907  |     |    |



- Straight drill/milling unit, double, Y axis**
- |              |              |     |    |
|--------------|--------------|-----|----|
| <b>ER 25</b> | 413002004-65 | 1:1 | EC |
|              | 00675000907  |     |    |

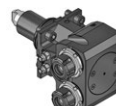

- 2-spindle - Right angle drill/milling unit, Y axis**
- |              |              |     |           |
|--------------|--------------|-----|-----------|
| <b>ER 25</b> | 413502006-65 | 1:1 | EC        |
|              | 00675000915  |     |           |
| <b>ER 25</b> | 413502007-65 | 1:1 | IC 80 bar |
|              | 00675000915  |     |           |



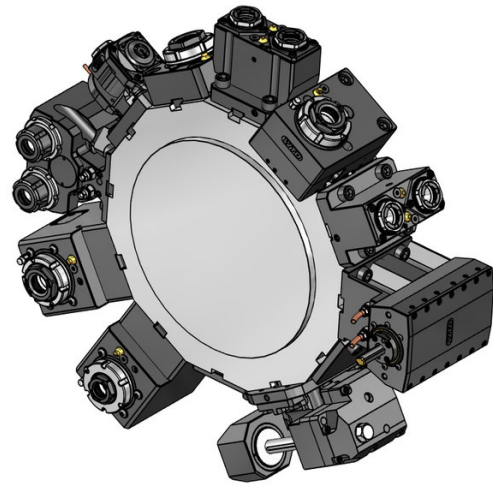
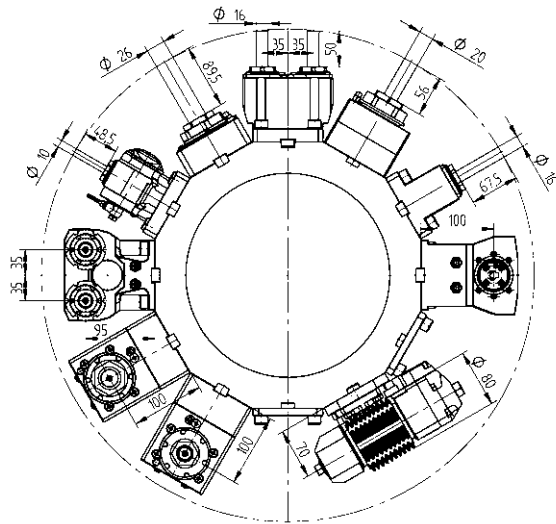

Driven Toolholders - Enhanced Program

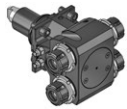

**2-spindle - Right angle drill/milling unit, both sides, Y axis**

**ER 25** 413502008-65 1:1 EC  
 00675000915



**Broaching unit for ID and OD**

**Type 32** 414532000-65 1:1 EC



**Broaching unit for ID and OD**

**Type 52** 414552000-65 1:1 EC

Standard reduction sleeves - cylindrical



**Reduction sleeve Ø 25**

240025006	ø 6
240025008	ø 8
240025010	ø 10
240025012	ø 12
240025014	ø 14
240025016	ø 16
240025020	ø 20



**Reduction sleeve Ø 32**

240032006	ø 6
240032008	ø 8
240032010	ø 10
240032012	ø 12
240032014	ø 14
240032016	ø 16
240032018	ø 18
240032020	ø 20
240032025	ø 25



**Reduction sleeve Ø 40**

240040006	ø 6
240040008	ø 8
240040010	ø 10
240040012	ø 12
240040014	ø 14
240040016	ø 16
240040020	ø 20
240040025	ø 25
240040032	ø 32



**Reduction sleeve Ø 50**

240050010	ø 10
240050012	ø 12
240050016	ø 16
240050020	ø 20
240050025	ø 25
240050032	ø 32
240050040	ø 40



**Reduction sleeve Ø 60**

240060012	ø 12
240060016	ø 16
240060020	ø 20
240060025	ø 25
240060032	ø 32
240060040	ø 40
240060050	ø 50

Standard reduction sleeves - cylindrical



**Reduction sleeve Ø 80**

240080020	ø 20
240080025	ø 25
240080032	ø 32
240080040	ø 40
240080050	ø 50
240080060	ø 60



**Reduction sleeve Ø 1"**

2400100025	ø 1/4"
2400100031	ø 5/16"
2400100038	ø 3/8"
2400100050	ø 1/2"
2400100063	ø 5/8"
2400100075	ø 3/4"



**Reduction sleeve Ø 1 1/4"**

2400125038	ø 3/8"
2400125050	ø 1/2"
2400125063	ø 5/8"
2400125075	ø 3/4"
2400125088	ø 7/8"
2400125100	ø 1"

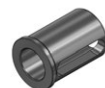

**Reduction sleeve Ø 1 1/2"**

2400150038	ø 3/8"
2400150050	ø 1/2"
2400150063	ø 5/8"
2400150075	ø 3/4"
2400150088	ø 7/8"
2400150100	ø 1"
2400150125	ø 1 1/4"

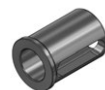

**Reduction sleeve Ø 2"**

2400200050	ø 1/2"
2400200063	ø 5/8"
2400200075	ø 3/4"
2400200088	ø 7/8"
2400200100	ø 1"
2400200125	ø 1 1/4"
2400200150	ø 1 1/2"
2400200175	ø 1 3/4"

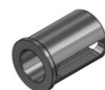

**Reduction sleeve Ø 3"**

2400300075	ø 3/4"
2400300100	ø 1"
2400300125	ø 1 1/4"
2400300150	ø 1 1/2"
2400300200	ø 2"
2400300250	ø 2 1/2"

Standard reduction sleeves - morse taper



**Reduction sleeve Ø 32**

240532001	MT 1
240532002	MT 2
240532003	MT 3

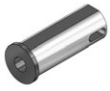

**Reduction sleeve Ø 40**

240540001	MT 1
240540002	MT 2
240540003	MT 3
240540004	MT 4

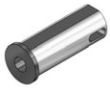

**Reduction sleeve Ø 50**

240550002	MT 2
240550003	MT 3
240550004	MT 4

Collets DIN 6499B (ER/ESX)



ER 11	mm	inch
190011000	∅ 7-0.5	∅ 0.276-0.020
190011010	∅ 1-0.5	∅ 0.039-0.020
190011015	∅ 1.5-1	∅ 0.059-0.039
190011020	∅ 2-1.5	∅ 0.079-0.059
190011025	∅ 2.5-2	∅ 0.098-0.079
190011030	∅ 3-2.5	∅ 0.118-0.098
190011035	∅ 3.5-3	∅ 0.138-0.118
190011040	∅ 4-3.5	∅ 0.158-0.138
190011045	∅ 4.5-4	∅ 0.177-0.158
190011050	∅ 5-4.5	∅ 0.197-0.177
190011055	∅ 5.5-5	∅ 0.217-0.197
190011060	∅ 6-5.5	∅ 0.236-0.217
190011065	∅ 6.5-6	∅ 0.256-0.236
190011070	∅ 7-6.5	∅ 0.276-0.256



ER 16	mm	inch
190016000	∅ 10-0.5	∅ 0.394-0.020
190016010	∅ 1-0.5	∅ 0.039-0.020
190016020	∅ 2-1	∅ 0.079-0.039
190016030	∅ 3-2	∅ 0.118-0.079
190016040	∅ 4-3	∅ 0.158-0.118
190016050	∅ 5-4	∅ 0.197-0.158
190016060	∅ 6-5	∅ 0.236-0.197
190016070	∅ 7-6	∅ 0.276-0.236
190016080	∅ 8-7	∅ 0.315-0.276
190016090	∅ 9-8	∅ 0.354-0.315
190016100	∅ 10-9	∅ 0.394-0.354



ER 20	mm	inch
190020000	∅ 13-1	∅ 0.512-0.039
190020010	∅ 1-0.5	∅ 0.039-0.020
190020020	∅ 2-1	∅ 0.079-0.039
190020030	∅ 3-2	∅ 0.118-0.079
190020040	∅ 4-3	∅ 0.157-0.118
190020050	∅ 5-4	∅ 0.197-0.157
190020060	∅ 6-5	∅ 0.236-0.197
190020070	∅ 7-6	∅ 0.276-0.236
190020080	∅ 8-7	∅ 0.315-0.276
190020090	∅ 9-8	∅ 0.354-0.315
190020100	∅ 10-9	∅ 0.394-0.354
190020110	∅ 11-10	∅ 0.433-0.394
190020120	∅ 12-11	∅ 0.472-0.433
190020130	∅ 13-12	∅ 0.512-0.472

Collets DIN 6499B (ER/ESX)



ER 25	mm	inch
190025000	∅ 16-1	∅ 0.630-0.039
190025010	∅ 1-0.5	∅ 0.039-0.020
190025020	∅ 2-1	∅ 0.079-0.039
190025030	∅ 3-2	∅ 0.118-0.079
190025040	∅ 4-3	∅ 0.157-0.118
190025050	∅ 5-4	∅ 0.197-0.157
190025060	∅ 6-5	∅ 0.236-0.197
190025070	∅ 7-6	∅ 0.276-0.236
190025080	∅ 8-7	∅ 0.315-0.276
190025090	∅ 9-8	∅ 0.354-0.315
190025100	∅ 10-9	∅ 0.394-0.354
190025110	∅ 11-10	∅ 0.433-0.394
190025120	∅ 12-11	∅ 0.472-0.433
190025130	∅ 13-12	∅ 0.512-0.472
190025140	∅ 14-13	∅ 0.551-0.512
190025150	∅ 15-14	∅ 0.591-0.551
190025160	∅ 16-15	∅ 0.630-0.591



ER 32	mm	inch
190032000	∅ 20-2	∅ 0.787-0.079
190032020	∅ 2-1	∅ 0.079-0.039
190032030	∅ 3-2	∅ 0.118-0.079
190032040	∅ 4-3	∅ 0.157-0.118
190032050	∅ 5-4	∅ 0.197-0.157
190032060	∅ 6-5	∅ 0.236-0.197
190032070	∅ 7-6	∅ 0.276-0.236
190032080	∅ 8-7	∅ 0.315-0.276
190032090	∅ 9-8	∅ 0.354-0.315
190032100	∅ 10-9	∅ 0.394-0.354
190032110	∅ 11-10	∅ 0.433-0.394
190032120	∅ 12-11	∅ 0.472-0.433
190032130	∅ 13-12	∅ 0.512-0.472
190032140	∅ 14-13	∅ 0.551-0.512
190032150	∅ 15-14	∅ 0.591-0.551
190032160	∅ 16-15	∅ 0.630-0.591
190032170	∅ 17-16	∅ 0.669-0.630
190032180	∅ 18-17	∅ 0.709-0.669
190032190	∅ 19-18	∅ 0.748-0.709
190032200	∅ 20-19	∅ 0.787-0.748

Collets DIN 6499B (ER/ESX)



**ER 40**

	mm	inch
190040000	ø 26-3	ø 1.024-0.118
190040030	ø 3-2	ø 0.118-0.079
190040040	ø 4-3	ø 0.157-0.118
190040050	ø 5-4	ø 0.197-0.157
190040060	ø 6-5	ø 0.236-0.197
190040070	ø 7-6	ø 0.276-0.236
190040080	ø 8-7	ø 0.315-0.276
190040090	ø 9-8	ø 0.354-0.315
190040100	ø 10-9	ø 0.394-0.354
190040110	ø 11-10	ø 0.433-0.394
190040120	ø 12-11	ø 0.472-0.433
190040130	ø 13-12	ø 0.512-0.472
190040140	ø 14-13	ø 0.551-0.512
190040150	ø 15-14	ø 0.591-0.551
190040160	ø 16-15	ø 0.630-0.591
190040170	ø 17-16	ø 0.669-0.630
190040180	ø 18-17	ø 0.709-0.669
190040190	ø 19-18	ø 0.748-0.709
190040200	ø 20-19	ø 0.787-0.748
190040210	ø 21-20	ø 0.827-0.787
190040220	ø 22-21	ø 0.866-0.827
190040230	ø 23-22	ø 0.906-0.866
190040240	ø 24-23	ø 0.945-0.906
190040250	ø 25-24	ø 0.984-0.945
190040260	ø 26-25	ø 1.024-0.984



**ER 50**

	mm	inch
190050000	ø 34-10	ø 1.339-0.394
190050060	ø 6-4	ø 0.236-0.157
190050080	ø 8-6	ø 0.315-0.236
190050100	ø 10-8	ø 0.394-0.315
190050120	ø 12-10	ø 0.472-0.394
190050140	ø 14-12	ø 0.551-0.472
190050160	ø 16-14	ø 0.630-0.551
190050180	ø 18-16	ø 0.709-0.630
190050200	ø 20-18	ø 0.787-0.709
190050220	ø 22-20	ø 0.866-0.787
190050240	ø 24-22	ø 0.945-0.866
190050260	ø 26-24	ø 1.024-0.945
190050280	ø 28-26	ø 1.102-1.024
190050300	ø 30-28	ø 1.181-1.102
190050320	ø 32-30	ø 1.260-1.181
190050340	ø 32-30	ø 1.260-1.181

Collets DIN 6499D (ER/ESX) - sealed, for IC



**ER 11**

191011030	ø 3
191011040	ø 4
191011050	ø 5
191011060	ø 6



**ER 16**

191016000	ø 3-10
191016030	ø 3
191016040	ø 4
191016050	ø 5
191016060	ø 6
191016070	ø 7
191016080	ø 8
191016090	ø 9
191016100	ø 10



**ER 20**

191020000	ø 3-12
191020030	ø 3
191020040	ø 4
191020050	ø 5
191020060	ø 6
191020070	ø 7
191020080	ø 8
191020090	ø 9
191020100	ø 10
191020110	ø 11
191020120	ø 12



**ER 25**

191025000	ø 4-16
191025030	ø 3
191025040	ø 4
191025050	ø 5
191025060	ø 6
191025070	ø 7
191025080	ø 8
191025090	ø 9
191025100	ø 10
191025110	ø 11
191025120	ø 12
191025130	ø 13
191025140	ø 14
191025150	ø 15
191025160	ø 16



Collets DIN 6499D (ER/ESX) - sealed, for IC



**ER 32**

191032000	ø 4-20
191032030	ø 3
191032040	ø 4
191032050	ø 5
191032060	ø 6
191032070	ø 7
191032080	ø 8
191032090	ø 9
191032100	ø 10
191032110	ø 11
191032120	ø 12
191032130	ø 13
191032140	ø 14
191032150	ø 15
191032160	ø 16
191032170	ø 17
191032180	ø 18
191032190	ø 19
191032200	ø 20



**ER 40**

191040060	ø 6
191040080	ø 8
191040100	ø 10
191040120	ø 12
191040140	ø 14
191040160	ø 16
191040180	ø 18
191040200	ø 20
191040220	ø 22
191040250	ø 25

Collets DIN 6499D (ER/DM) - metallic sealed, for IC



**ER 11**

191111013-in	ø 0.125
191111019-in	ø 0.188
191111025-in	ø 0.25



**ER 16**

191116001-in	ø 0.125-0.375
191116013-in	ø 0.125
191116019-in	ø 0.188
191116025-in	ø 0.25
191116031-in	ø 0.313
191116038-in	ø 0.375



**ER 20**

191120001-in	ø 0.125-0.5
191120013-in	ø 0.125
191120019-in	ø 0.188
191120025-in	ø 0.25
191120031-in	ø 0.313
191120038-in	ø 0.375
191120044-in	ø 0.438
191120050-in	ø 0.5



**ER 25**

191125001-in	ø 0.25-0.625
191125025-in	ø 0.25
191125031-in	ø 0.313
191125038-in	ø 0.375
191125044-in	ø 0.438
191125050-in	ø 0.5
191125056-in	ø 0.563
191125063-in	ø 0.625



**ER 32**

191132001-in	ø 0.25-0.75
191132025-in	ø 0.25
191132031-in	ø 0.313
191132038-in	ø 0.375
191132044-in	ø 0.438
191132050-in	ø 0.5
191132056-in	ø 0.563
191132063-in	ø 0.625
191132069-in	ø 0.688
191132075-in	ø 0.75

Collets DIN 6499D (ER/DM) - metallic sealed,  
for IC

**ER 40**

191140025-in	ø 0.25
191140031-in	ø 0.313
191140038-in	ø 0.375
191140044-in	ø 0.438
191140050-in	ø 0.5
191140056-in	ø 0.563
191140063-in	ø 0.625
191140069-in	ø 0.688
191140075-in	ø 0.75
191140088-in	ø 0.875
191140100-in	ø 1

---

---

---

---

---

---

---

---

---

---

---

---

---

---

---

---

---

---

---

---

---

---

---

---

---

---

---

---



## Quality without compromise.

All manufacturing steps are based on highest precision.

According to our own device that for the manufacture of high precision tooling systems high precision machine tools are essential we only use the latest machine tool technology to manufacture our parts.

At WTO not only the final products but also all manufacturing steps are checked and documented. All our products are measured on high precision 3D-coordinate-measuring machines.

# WTO worldwide

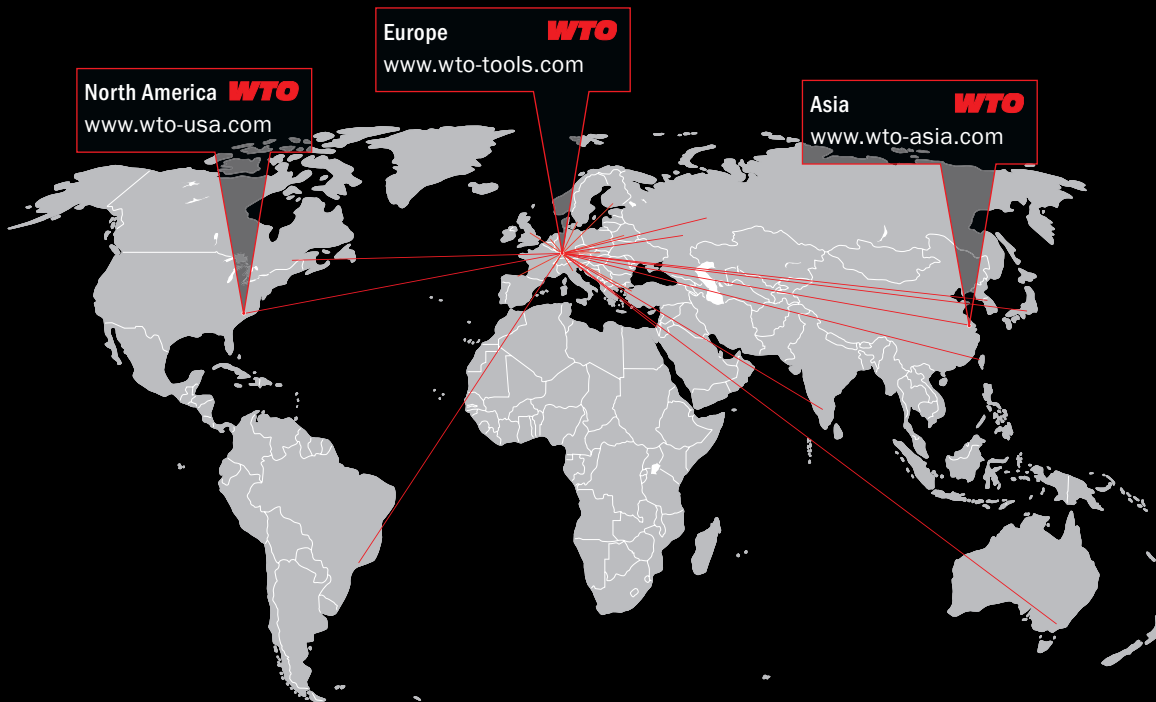

WTO Werkzeug-  
Einrichtungen GmbH  
Neuer Hohdammweg 1  
77797 Ohlsbach  
Germany

WTO Inc.  
13900-F South Lakes Dr.  
Charlotte, NC 28273  
USA

WTO Asia  
WTO Precision Tool Holders  
(Shanghai) Co. Ltd.  
Room 109-110, Building 2  
No. 228 Banting Road  
Jiuting Town,  
Songjiang District  
201615 Shanghai  
China

## Our distribution partners. Competence right there.

**Australia**  
Dimac Tooling Ltd.  
sales@dimac.com.au

**Brazil**  
TF2  
tfdois@tfdois.com.br

**Canada**  
Mittmann Industrial Inc.  
info@mittmann.com

**China**  
Shanghai Gangde  
wtocando@yahoo.com

**Czech Republic**  
ALBA precision, spol. s.r.o.  
info@albaprecision.cz

**Denmark**  
AVN Teknik A/S  
cjo@avn.dk

**Finland**  
Suomen Terätuonti Oy  
myynti@stt.as

**France, east**  
Alexandre Mathelin  
alm@wto.de

**France, west**  
Christophe Archambault  
car@wto.de

**Great Britain**  
Cutwel Ltd.  
sales@cutwel.net

**Hungary**  
Prevotex Hungary Kft.  
info@prevotex.hu

**India**  
Ulhas Patil  
u.patil@wto-asia.com

**Israel**  
E.Y.A.R. Ltd.  
boris@eyar.co.il

**Italy**  
Prymark srl  
commerciale@prymark.it

**Japan**  
NK Works Co. Ltd.  
k\_samba@nk-works.co.jp

**Korea**  
WTO Office Korea  
is.chon@wto-korea.com

**Mexico**  
Workholding Engineering De México  
info@wem.com.mx

**Netherlands**  
Toologic BeNeLux B.V.  
info@toologic-benelux.nl

**Norway**  
Helge Karlsen Verktøy og Maskin AS  
hkvm@hkvm.no

**Poland**  
ARCO Andrzej Rudenko  
info@arcotools.pl

**Romania**  
SC Elif Trading SRL  
bulent.ozkan@eliftrading.com

**Slovakia**  
ALBA precision s.r.o.  
albaprecision@albaprecision.sk

**Spain**  
ITALMATIC, S.A.  
italmatic@italmatic.es

**Sweden**  
Bonhron & Ewing AB  
info@bonhron-ewing.se

**Switzerland**  
Utilis AG  
info@utilis.com

**Taiwan**  
Kaiko Co., Ltd.  
info@kaiko.com.tw

**Turkey**  
MYK CNC MAKINA SAN. VE  
huseyin.tatlidil@mykcnc.com.tr

**Ukraine**  
„LLC“ SPA Stankopromimport  
info@phoenix-ua.com