

刀座产品目录

Lynx 2100 M/MS/LY/LSY
Lynx 300 M, 2600 Y, Puma GT2100, 2600 M
Lynx 2600 SY (12ST)
Puma 2100, 2600(II) M/MS/Y/SY (BMT55)
Puma 2100, 2600(II) M/MS/Y/SY (BMT65)
Puma 2100, 2600 Y/SY (16ST, BMT55)
Puma 3100 M/Y/SY, GT3100 M
Puma 4100, 5100 M/LM/LY
Puma 600, 700, 800 M/LM/LY
Puma DNT 2100-2600 (BMT55)
Puma DNT 2100-2600 (BMT65)
Puma MX1600 ST (BMT45)
Puma MX1600, 2100 ST (BMT55)
Puma MX2600 T/ST
Puma SMX2100 ST
Puma SMX2600, 3100 ST
Puma TT1300 SY/SYY
Puma TT1800, 2100 MS/SY/SYY
Puma TT2500 MS/SY

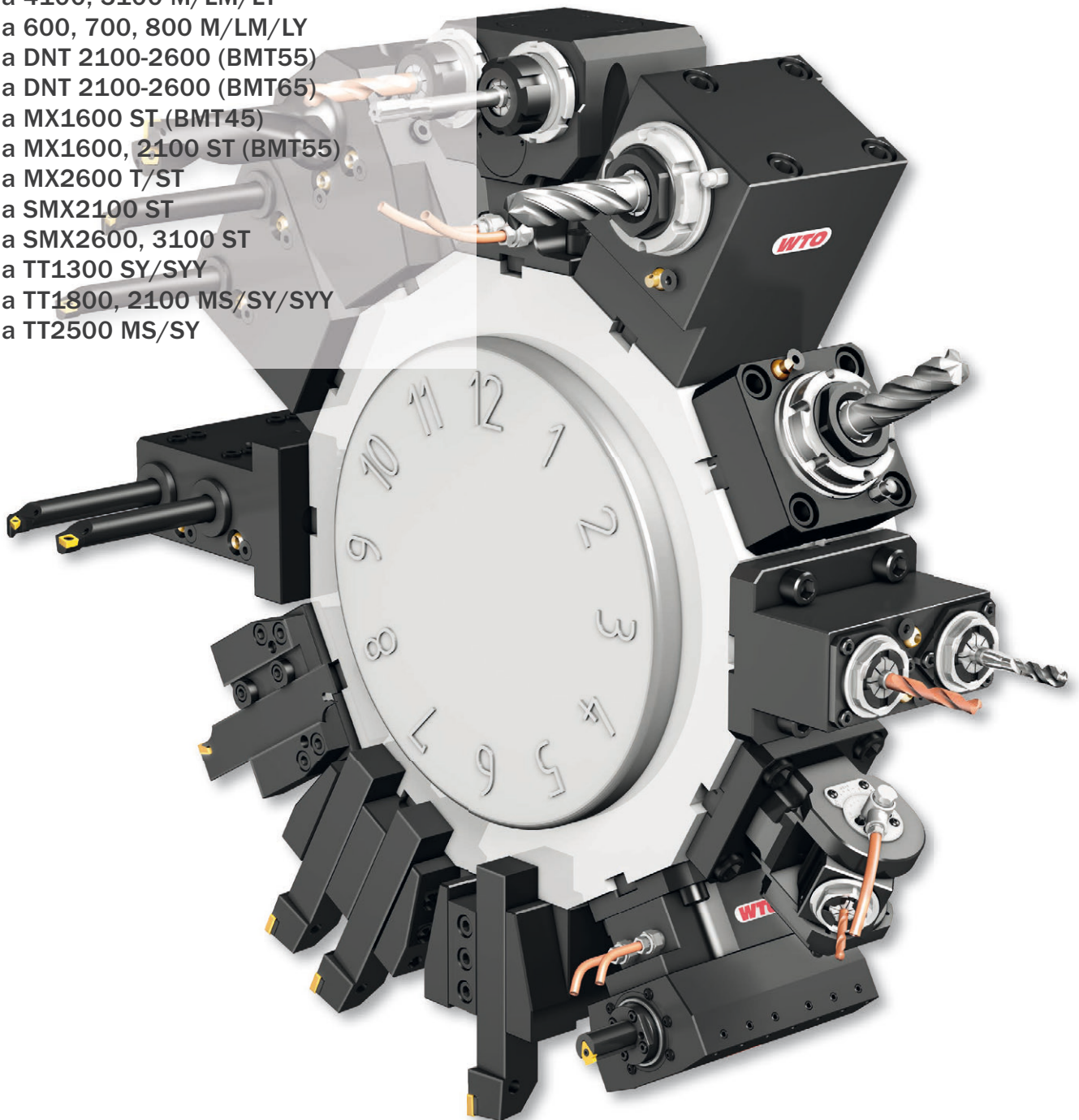

QuickFlex®

全新快换系统提供高效能和高精密度

最小的投资, 最大的扩展性

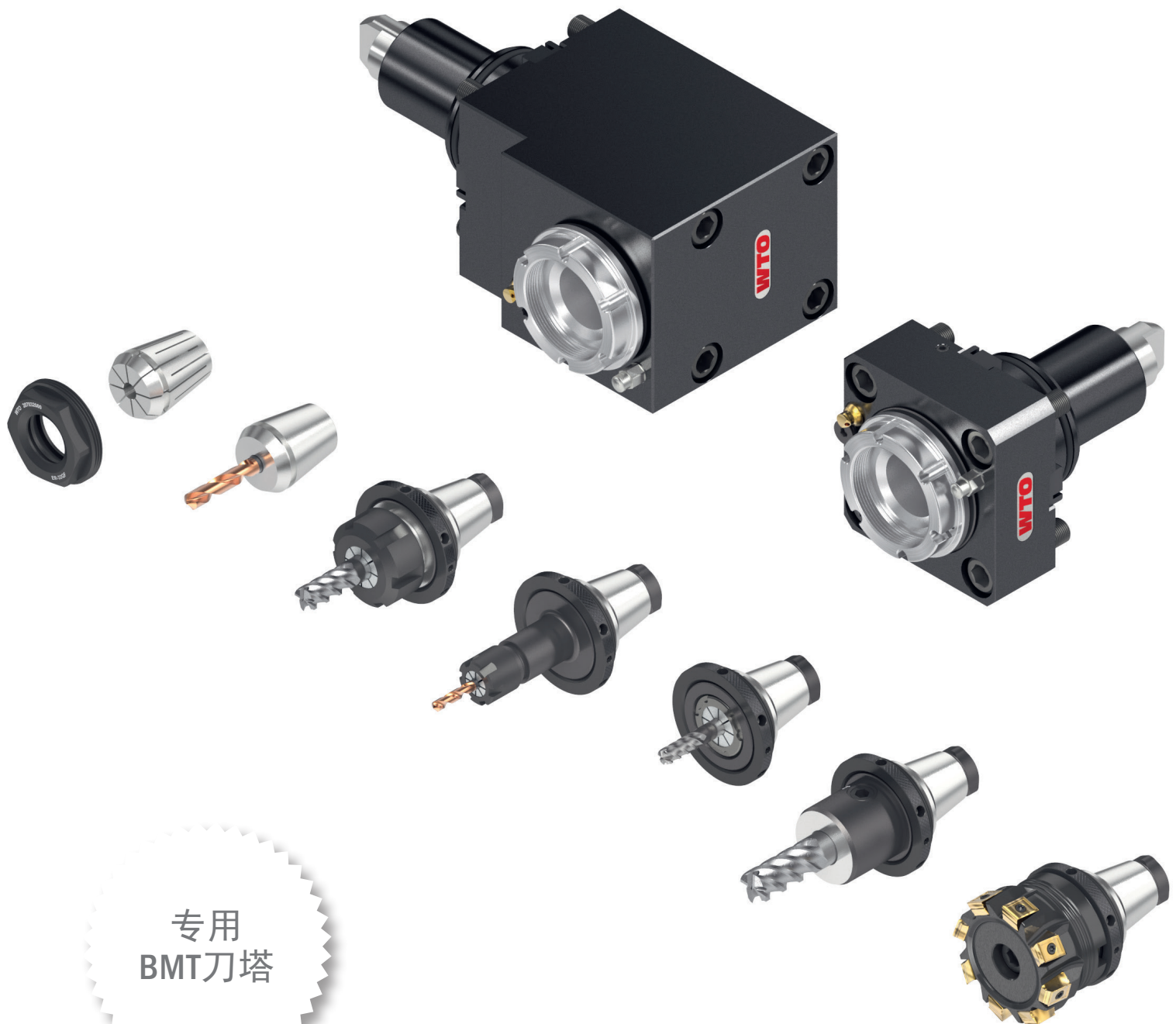

Lynx 2100 M/M/S/LY/LSY	页	4 - 8
Lynx 300 M,2600 Y, Puma GT2100,2600 M	页	9 - 11
Lynx 2600 SY (12ST)	页	12 - 16
Puma 2100,2600(II) M/M/S/Y/SY (BMT55)	页	17 - 22
Puma 2100,2600(II) M/M/S/Y/SY (BMT65)	页	23 - 27
Puma 2100, 2600 Y/SY (16ST, BMT55)	页	28 - 31
Puma 3100 M/Y/SY, GT3100 M	页	32 - 36
Puma 4100, 5100 M/LM/LY	页	37 - 39
Puma 600, 700, 800 M/LM/LY	页	40 - 41
Puma DNT 2100-2600 (BMT55)	页	42 - 44
Puma DNT 2100-2600 (BMT65)	页	45 - 47
Puma MX1600 ST (BMT45)	页	48 - 50
Puma MX1600, 2100 ST (BMT55)	页	51 - 54
Puma MX2600 T/ST	页	55 - 58
Puma SMX2100 ST	页	59 - 62
Puma SMX2600, 3100 ST	页	63 - 66
Puma TT1300 SY/SYY	页	67 - 69
Puma TT1800, 2100 MS/SY/SYY	页	70 - 73
Puma TT2500 MS/SY	页	74 - 78
变径套	页	79 - 80
筒夹	页	81 - 83

EC = 外部切削液供应
HP-IC = 高压内部切削液供应通过切削工具
IC 80 bar = 内部+外部切削液供应
 最高切削液压力 = 80 bar
IC 30 bar = 内部+外部切削液供应
 最高切削液压力 = 30 bar
 仅使用被滤网过的切削液(最大颗粒小于50 µm)
 不开启冷却液, 刀座不能运行
 不能对铸铁类材料加工, 如生铁等

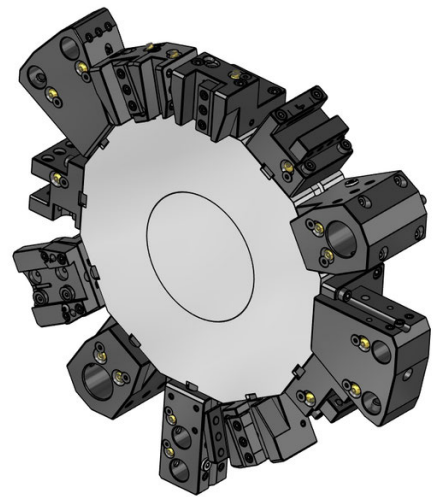
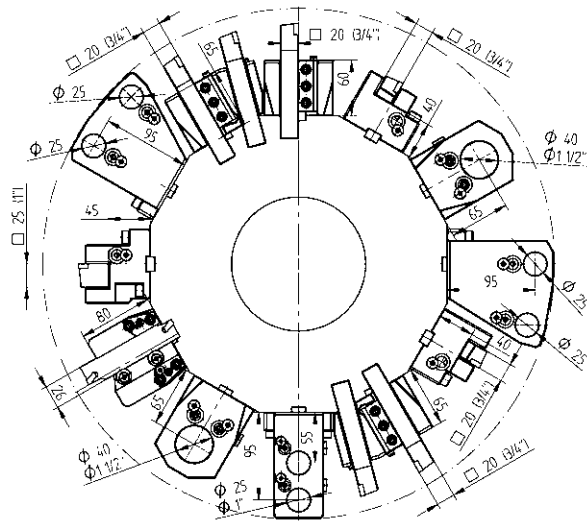

固定刀座 - 标准产品目录

固定刀座 - 标准产品目录

- 

20 车端面 and 车削刀座
48-95083
- 

20 车端面 and 车削刀座, HP-IC
48-100605-HP IC 80 bar
- 

25 车端面 and 车削刀座, HP-IC
48-104395-HP IC 80 bar
- 

20 车端面 and 车削刀座, 两侧的
48-95085
- 

20 车端面 and 车削刀座, 两侧的, HP-IC
48-95085-HP IC 80 bar
- 

20 车端面 and 镗削刀座
48-109148
- 

20 车端面 and 镗削刀座, HP-IC
48-109148-HP IC 80 bar

- 

25 车端面 and 镗削刀座, HP-IC
48-104397-HP IC 80 bar
- 

Ø 40 组合刀座, LF=65
48-95090 IC 80 bar
- 

Ø 32 组合刀座, 通用的, LF=85
48-95998 IC 80 bar

 -  241132016 ER25
 -  241132020 ER32
- 

Ø 25 镗刀刀座, 2刀位, 通用的
48-95093

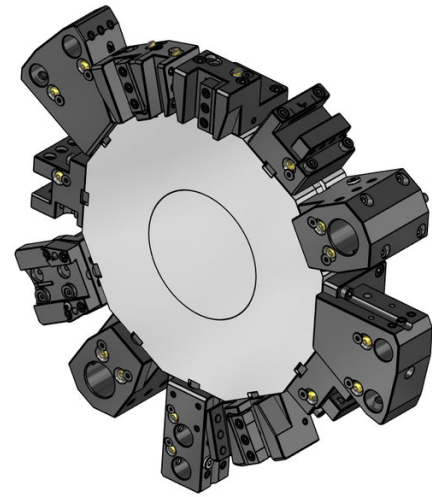
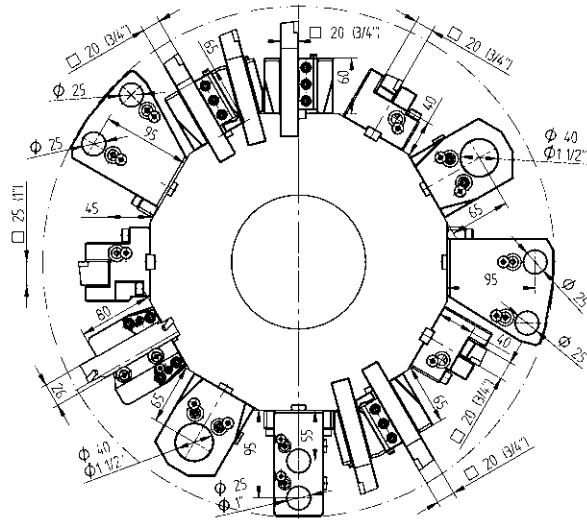

固定刀座 - 扩展产品目录



20

车端面 and 车削刀座, 2刀位, 24站位

48-95088



20

车端面 and 车削刀座, 两侧的, 2刀位, 24站位

48-95355



20 (3/4")

车端面 and 车削刀座, 两侧的, 2刀位, Y-轴

48-110811



SH 26

切断刀用刀座, 可调节的

48-94968



SH 26

切断刀用刀座, 可调节的, 内部切削液供应, HP-IC

SH 26

48-102252R

IC 80 bar

SH 26

48-102252L

IC 80 bar



Ø 25

镗刀刀座, 通用的, 2刀位, 24站位

48-95092

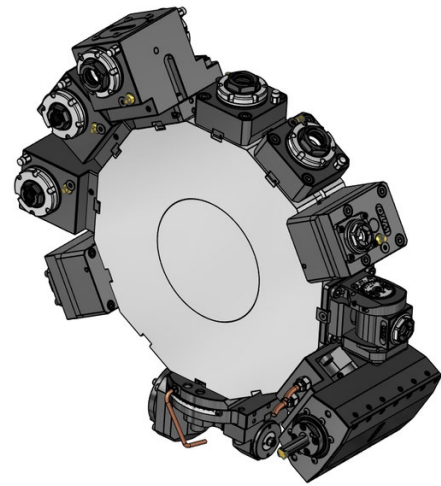
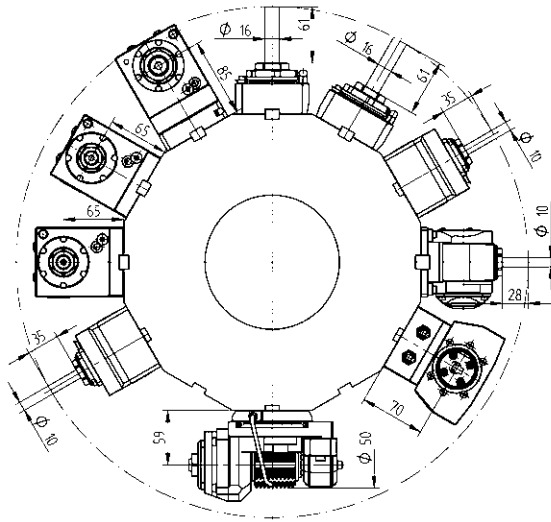

动力刀座 - QuickFlex®



直结式钻/铣动力刀座

- | | | | |
|----------|--------------|-----|-----------|
| ER-25 QF | 420125015-45 | 1:1 | EC |
| | 0067725000 | | |
| ER-25 QF | 420125016-45 | 1:1 | IC 80 bar |
| | 0067725000 | | |



直结式钻/铣动力刀座 (12000 RPM)

- | | | | |
|----------|--------------|-----|------------|
| ER-25 QF | 430125019-45 | 1:1 | EC |
| | 0067725000 | | |
| ER-25 QF | 430125020-45 | 1:1 | IC 100 bar |
| | 0067725000 | | |



直角式钻/铣动力刀座, LF=65

- | | | | |
|----------|--------------|-----|-----------|
| ER-25 QF | 420525015-45 | 1:1 | EC |
| | 0067725000 | | |
| ER-25 QF | 420525016-45 | 1:1 | IC 80 bar |
| | 0067725000 | | |

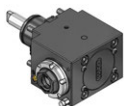

直角式钻/铣动力刀座 (12000 RPM)

- | | | | |
|----------|--------------|-----|-----------|
| ER-25 QF | 420525054-45 | 1:1 | EC |
| | 0067725000 | | |
| ER-25 QF | 420525055-45 | 1:1 | IC 80 bar |
| | 0067725000 | | |

动力刀座 - QuickFlex®



直角后缩式钻/铣动力刀座, K2=85

- | | | | |
|----------|--------------|-----|-----------|
| ER-25 QF | 420525024-45 | 1:1 | EC |
| | 0067725000 | | |
| ER-25 QF | 420525025-45 | 1:1 | IC 80 bar |
| | 0067725000 | | |



直角后缩式钻/铣动力刀座, LF=85, (12000 RPM)

- | | | | |
|----------|--------------|-----|-----------|
| ER-25 QF | 420525049-45 | 1:1 | EC |
| | 0067725000 | | |
| ER-25 QF | 420525050-45 | 1:1 | IC 80 bar |
| | 0067725000 | | |



直角式钻/铣动力刀座, 两侧的, LF=85

- | | | | |
|----------|--------------|-----|----|
| ER-25 QF | 420525043-45 | 1:1 | EC |
| | 0067725000 | | |



直角式钻/铣动力刀座, 两侧的, LF=85, (12000 RPM)

- | | | | |
|----------|--------------|-----|----|
| ER-25 QF | 420525051-45 | 1:1 | EC |
| | 0067725000 | | |

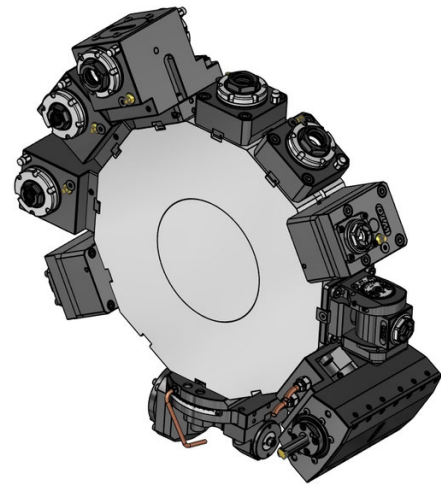
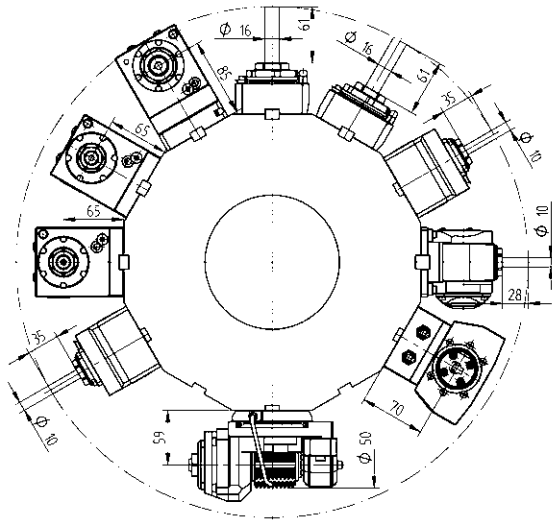

动力刀座 - 扩展产品目录



直结偏位式钻/铣动力刀座

- | | | | |
|-------|--------------|-----|-----------|
| ER 16 | 410410008-45 | 1:3 | EC |
| | 00675000937 | | |
| ER 16 | 410410002-45 | 1:3 | IC 80 bar |
| | 00675000937 | | |



直角式钻/铣动力刀座, LF=65

- | | | | |
|----------|--------------|-----|-----------|
| ER-20 QF | 420520018-45 | 1:2 | EC |
| | 0067720001 | | |
| ER-20 QF | 420520019-45 | 1:2 | IC 80 bar |
| | 0067720001 | | |
| ER-25 QF | 420525020-45 | 2:1 | EC |
| | 0067725000 | | |
| ER-25 QF | 420525021-45 | 2:1 | IC 80 bar |
| | 0067725000 | | |



可调角度钻/铣动力刀座

- | | | | |
|-------|--------------|-----|-----------|
| ER 16 | 411010008-45 | 1:1 | EC |
| | 00675000902 | | |
| ER 16 | 411010009-45 | 1:1 | IC 80 bar |
| | 00675000902 | | |
| ER 11 | 411007004-45 | 1:2 | EC |
| | 00675000914 | | |
| ER 11 | 411007005-45 | 1:2 | IC 80 bar |
| | 00675000914 | | |

动力刀座 - 扩展产品目录



滚齿刀座

- | | | | |
|---------|------------------|-----|----|
| 15-2 型式 | 410900003-45 | 1:1 | EC |
| | 00675001015 | | |
| | 160008152 Ø 8 | | |
| | 160010152 Ø 10 | | |
| | 160013152 Ø 13 | | |
| | 160016152 Ø 16 | | |
| | 160022152 Ø 22 | | |
| | 160015152 Ø 5/8" | | |
| | 160019152 Ø 3/4" | | |
| | 110587 | | |



直结式钻/铣刀座, 2刀位, Y-轴

- | | | | |
|-------|--------------|-----|-----------|
| ER 20 | 413002006-45 | 1:1 | EC |
| | 00675000947 | | |
| ER 20 | 413002008-45 | 1:1 | IC 80 bar |
| | 00675000947 | | |



二轴直角式钻/铣动力刀座, Y-轴

- | | | | |
|-------|--------------|-----|-----------|
| ER 20 | 413502001-45 | 1:1 | EC |
| | 00675000939 | | |
| ER 20 | 413502002-45 | 1:1 | IC 80 bar |
| | 00675000939 | | |

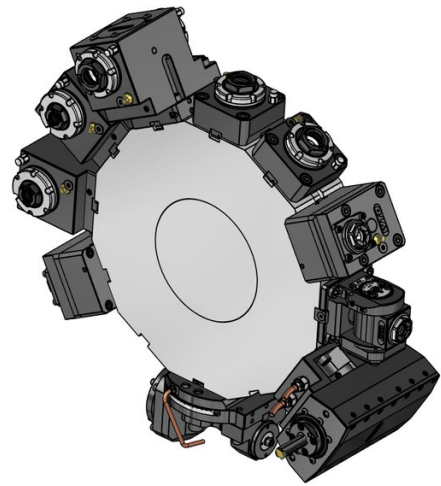
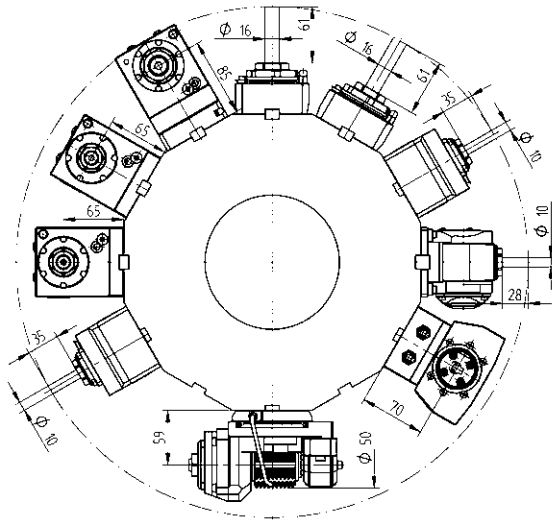

动力刀座 - 扩展产品目录



插槽刀座(内外径通用)

32 型式

414532005-45

1:1 EC

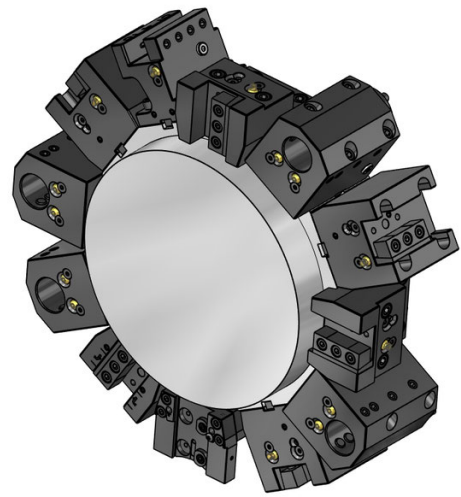
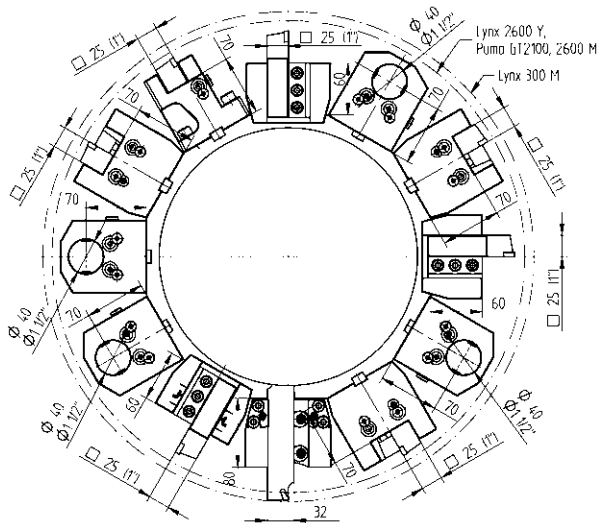



固定刀座 - 标准产品目录

固定刀座 - 扩展产品目录

- 

25 车端面 and 车削刀座
48-87097
- 

25 车端面 and 车削刀座, HP-IC
48-87097-HP IC 80 bar
- 

25 车端面 and 镗削刀座
48-87101
- 

25 车端面 and 镗削刀座, HP-IC
48-87101-HP IC 80 bar
- 

组合刀座, LF=70
Ø 32 48-106897 IC 80 bar
Ø 40 48-87103 IC 80 bar
- 

防护板
48-87111

- 

25(1") 车端面 and 车削刀座, 2刀位, Y-轴
48-87140
- 

SH 32 切断刀用刀座, 可调节的
48-103287
- 

SH 32 切断刀用刀座, 可调节的, 内部切削液供应, HP-IC
SH 32 48-110160R IC 80 bar
SH 32 48-110160L IC 80 bar
- 

Ø 25 镗刀刀座, 两侧的, 2刀位, Y-轴, 短型
48-98353

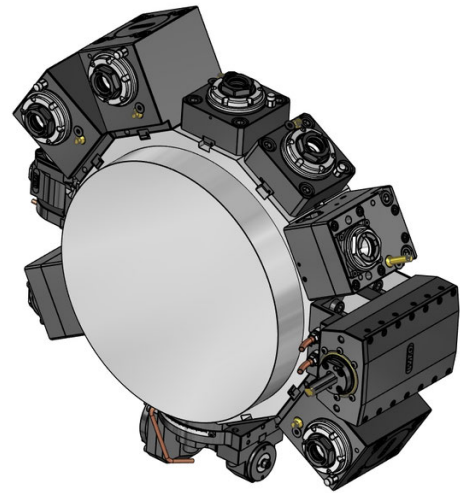
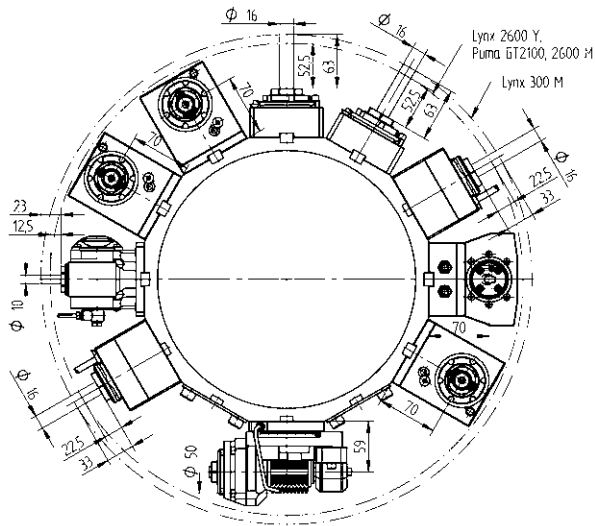

动力刀座 - QuickFlex®



直结式钻/铣动力刀座

ER-25 QF	420125015-55	1:1	EC
	0067725000		
ER-25 QF	420125016-55	1:1	IC 80 bar
	0067725000		



直角式钻/铣动力刀座, LF=70

ER-25 QF	420525015-55	1:1	EC
	0067725000		
ER-25 QF	420525016-55	1:1	IC 80 bar
	0067725000		

动力刀座 - 扩展产品目录



直结式钻/铣动力刀座

ER 32	410120010-55	1:1	EC
	0067725000		
ER 32	410120011-55	1:1	IC 80 bar
	0067725000		



直结式铣刀座 - 组合铣刀心轴, DIN6358

Ø 22	410222004-55	1:1	EC
	00675000483		



直结偏位式钻/铣动力刀座

ER 25	410116029-55	1:1	EC
	00675000932		
ER 25	410116030-55	1:1	IC 80 bar
	00675000932		
ER 20	410113009-55	1:2	EC
	00675000939		
ER 20	410113010-55	1:2	IC 80 bar
	00675000939		
ER 16	410410004-55	1:3	EC
	00675000937		
ER 16	410410005-55	1:3	IC 80 bar
	00675000937		

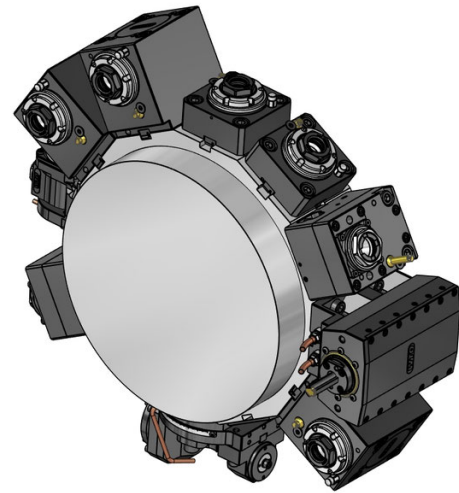
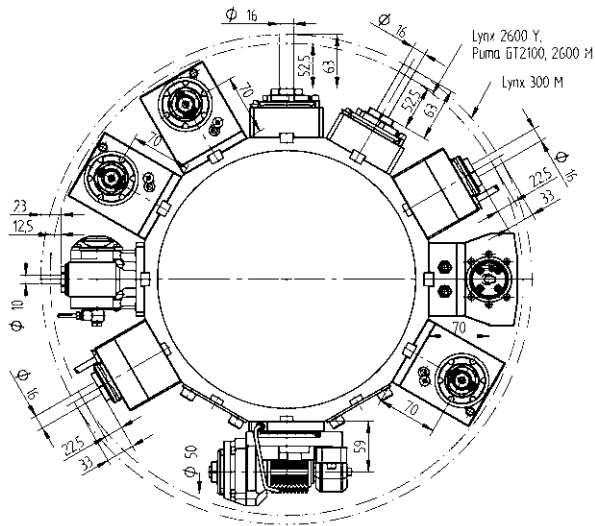

动力刀座 - 扩展产品目录



直角式钻/铣动力刀座, LF=70

ER 32	410520033-55	1:1	EC
	0067725000		
ER 32	410520034-55	1:1	IC 80 bar
	0067725000		
ER-20 QF	420520012-55	1:2	EC
	0067720001		
ER-20 QF	420520013-55	1:2	IC 80 bar
	0067720001		
ER 16	410810016-55	1:3	EC
	00675000841		
ER 16	410810017-55	1:3	IC 80 bar
	00675000841		
ER-25 QF	420525030-55	2:1	EC
	0067725000		
ER-25 QF	420525031-55	2:1	IC 80 bar
	0067725000		



直角式铣动力刀座 - 铣刀心轴, DIN6358, LF=70

Ø 22	410622010-55	1:1	EC
	00675000483		

动力刀座 - 扩展产品目录



可调角度钻/铣动力刀座

ER 16	411010005-55	1:1	EC
	00675000902		
ER 16	411010006-55	1:1	IC 80 bar
	00675000902		
ER 11	411007007-55	1:2	EC
	00675000914		
ER 11	411007008-55	1:2	IC 80 bar
	00675000914		



滚齿刀座

15-2 型式	410900002-55	1:1	EC
	00675001015		
	160008152 Ø 8		
	160010152 Ø 10		
	160013152 Ø 13		
	160016152 Ø 16		
	160022152 Ø 22		
	160015152 Ø 5/8"		
	160019152 Ø 3/4"		
	110587		



插槽刀座(内外径通用)

32 型式	414532001-55	1:1	EC
52 型式	414552000-55	1:1	EC

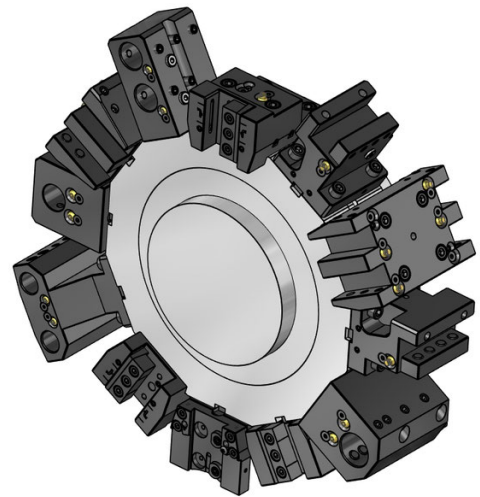
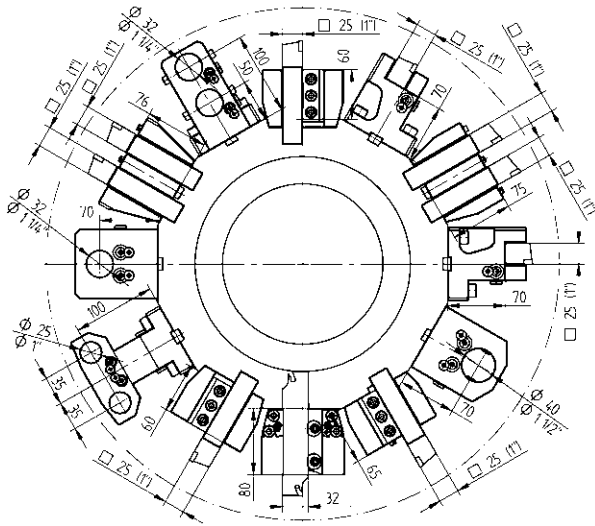



固定刀座 - 标准产品目录

固定刀座 - 标准产品目录

- 

25 车端面 and 车削刀座
48-87097
- 

25 车端面 and 车削刀座, HP-IC
48-87097-HP IC 80 bar
- 

25 车端面 and 车削刀座, 两侧的
48-87099
- 

25 车端面 and 车削刀座, 两侧的, HP-IC
48-87099-HP IC 80 bar
- 

25 车端面 and 镗削刀座
48-87101
- 

25 车端面 and 镗削刀座, HP-IC
48-87101-HP IC 80 bar
- 

Ø 32 组合刀座, LF=70
48-106897 IC 80 bar
Ø 40 48-87103 IC 80 bar

- 

Ø 32 镗刀刀座, 2刀位
48-87149
- 

防护板
48-87111

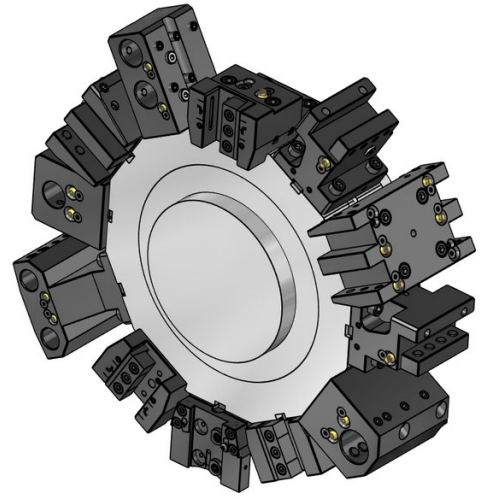
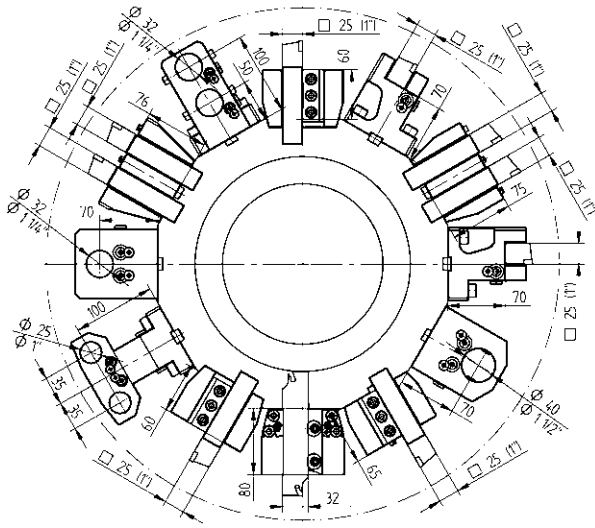

固定刀座 - 扩展产品目录



25(1")

车端面 and 车削刀座, 2刀位, Y-轴

48-87140



25(1")

车端面 and 车削刀座, 两侧的, 2刀位, Y-轴

48-87141



SH 32

切断刀用刀座, 可调节的

48-103287



SH 32

切断刀用刀座, 可调节的, 内部切削液供应, HP-IC

SH 32

48-110160R

IC 80 bar

SH 32

48-110160L

IC 80 bar



Ø 25

镗刀刀座, 两侧的, 2刀位, Y-轴

48-87147

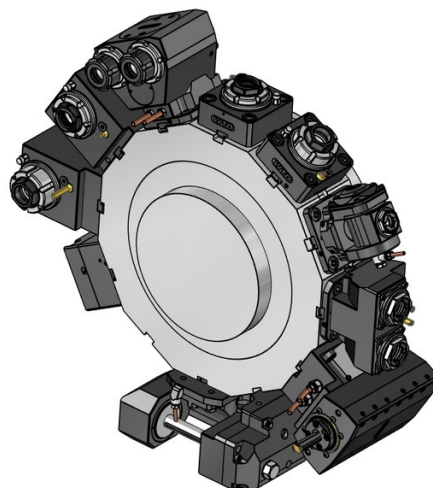
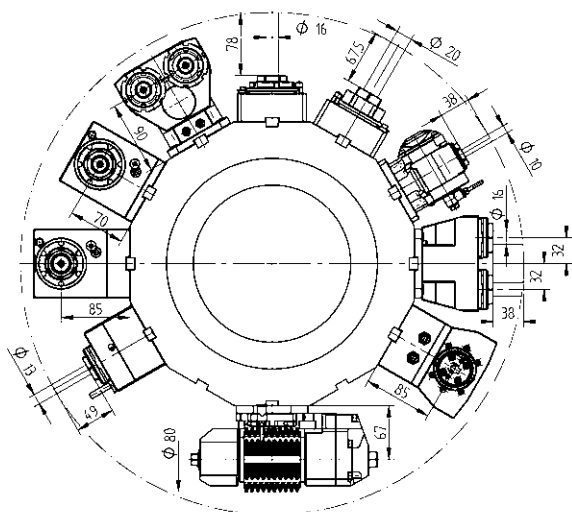

动力刀座 - QuickFlex®



直结式钻/铣动力刀座

- | | | | |
|----------|--------------|-----|-----------|
| ER-25 QF | 420125015-55 | 1:1 | EC |
| | 0067725000 | | |
| ER-25 QF | 420125016-55 | 1:1 | IC 80 bar |
| | 0067725000 | | |



直角式钻/铣动力刀座, LF=70

- | | | | |
|----------|--------------|-----|-----------|
| ER-25 QF | 420525015-55 | 1:1 | EC |
| | 0067725000 | | |
| ER-25 QF | 420525016-55 | 1:1 | IC 80 bar |
| | 0067725000 | | |



直角式钻/铣动力刀座, LF=85

- | | | | |
|----------|--------------|-----|-----------|
| ER-25 QF | 420525018-55 | 1:1 | EC |
| | 0067725000 | | |
| ER-25 QF | 420525019-55 | 1:1 | IC 80 bar |
| | 0067725000 | | |



直角式钻/铣动力刀座, 两侧的, LF=85

- | | | | |
|----------|--------------|-----|----|
| ER-25 QF | 420525020-55 | 1:1 | EC |
| | 0067725000 | | |

动力刀座 - 扩展产品目录



直结式钻/铣动力刀座

- | | | | |
|-------|--------------|-----|-----------|
| ER 32 | 410120010-55 | 1:1 | EC |
| | 0067725000 | | |
| ER 32 | 410120011-55 | 1:1 | IC 80 bar |
| | 0067725000 | | |



直结式铣刀座 - 组合铣刀心轴, DIN6358

- | | | | |
|------|--------------|-----|----|
| Ø 22 | 410222004-55 | 1:1 | EC |
| | 00675000483 | | |

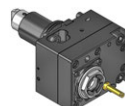

直结偏位式钻/铣动力刀座

- | | | | |
|-------|--------------|-----|-----------|
| ER 25 | 410116029-55 | 1:1 | EC |
| | 00675000932 | | |
| ER 25 | 410116030-55 | 1:1 | IC 80 bar |
| | 00675000932 | | |
| ER 20 | 410113009-55 | 1:2 | EC |
| | 00675000939 | | |
| ER 20 | 410113010-55 | 1:2 | IC 80 bar |
| | 00675000939 | | |
| ER 16 | 410410004-55 | 1:3 | EC |
| | 00675000937 | | |
| ER 16 | 410410005-55 | 1:3 | IC 80 bar |
| | 00675000937 | | |

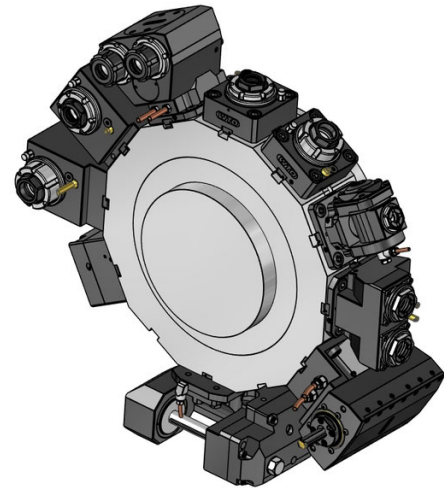
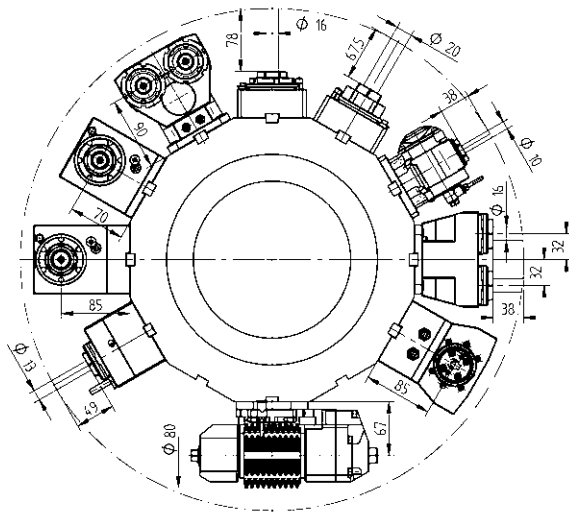

动力刀座 - 扩展产品目录



直角式钻/铣动力刀座, LF=70

ER 32	410520033-55 0067725000	1:1	EC
ER 32	410520034-55 0067725000	1:1	IC 80 bar
ER-20 QF	420520012-55 0067720001	1:2	EC
ER-20 QF	420520013-55 0067720001	1:2	IC 80 bar
ER 16	410810016-55 00675000841	1:3	EC
ER 16	410810017-55 00675000841	1:3	IC 80 bar
ER-25 QF	420525030-55 0067725000	2:1	EC
ER-25 QF	420525031-55 0067725000	2:1	IC 80 bar



直角式钻/铣动力刀座, LF=85

ER 32	410520030-55 0067725000	1:1	EC
ER 32	410520031-55 0067725000	1:1	IC 80 bar
ER-20 QF	420520014-55 0067720001	1:2	EC
ER-20 QF	420520015-55 0067720001	1:2	IC 80 bar
ER 16	410810020-55 00675000841	1:3	EC
ER 16	410810021-55 00675000841	1:3	IC 80 bar
ER-25 QF	420525032-55 0067725000	2:1	EC
ER-25 QF	420525033-55 0067725000	2:1	IC 80 bar



直角式铣动力刀座 - 铣刀心轴, DIN6358, LF=70

Ø 22	410622010-55 00675000483	1:1	EC
------	-----------------------------	-----	----



直角式铣动力刀座 - 铣刀心轴, DIN6358, LF=85

Ø 22	410622011-55 00675000483	1:1	EC
------	-----------------------------	-----	----

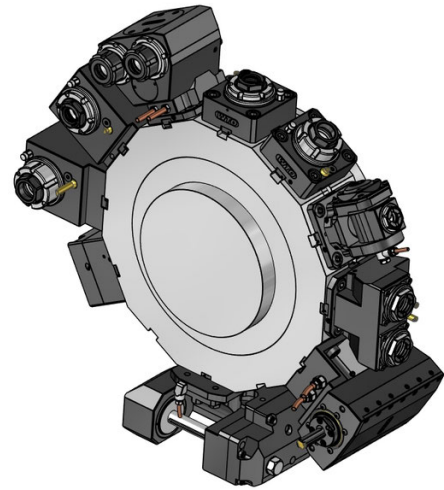
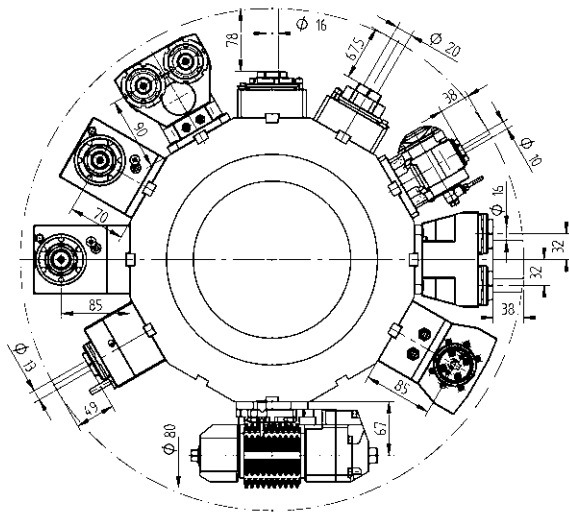

动力刀座 - 扩展产品目录

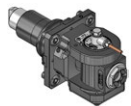

可调角度钻/铣动力刀座

ER 16	411010005-55	1:1	EC
	00675000902		
ER 16	411010006-55	1:1	IC 80 bar
	00675000902		
ER 11	411007007-55	1:2	EC
	00675000914		
ER 11	411007008-55	1:2	IC 80 bar
	00675000914		



滚齿刀座

16-1 型式	411500002-55	1:1	EC
16-1 型式	411500001-55	2:1	EC
	00675000927		
	160016161 Ø 16		
	160022161 Ø 22		
	160027161 Ø 27		
	160015161 Ø 5/8"		
	160019161 Ø 3/4"		
	160025161 Ø 1"		
	160031161 Ø 1 1/4"		
	110587		

动力刀座 - 扩展产品目录



直结式钻/铣刀座, 2刀位, Y-轴

ER 25	413002004-55	1:1	EC
	00675000970		
ER 25	413002003-55	1:1	IC 80 bar
	00675000970		



二轴直角式钻/铣动力刀座, Y-轴

ER 25	413502007-55	1:1	EC
	00675000915		
ER 25	413502008-55	1:1	IC 80 bar
	00675000915		

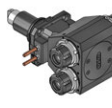

二轴直角式钻/铣动力刀座, 两侧的, Y-轴

ER 25	413502006-55	1:1	EC
	00675000915		

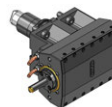

插槽刀座(内外径通用)

32 型式	414532000-55	1:1	EC
-------	--------------	-----	----

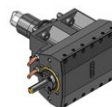

插槽刀座(内外径通用)

52 型式	414552002-55	1:1	EC
-------	--------------	-----	----

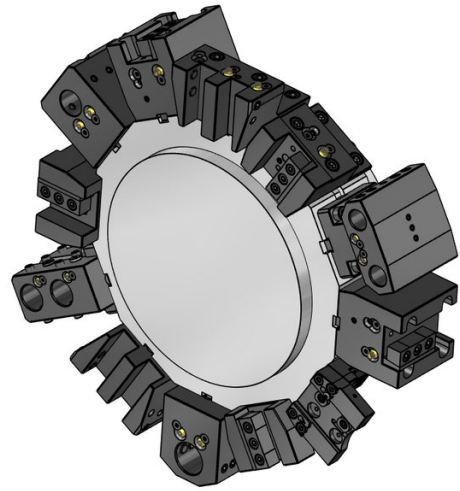
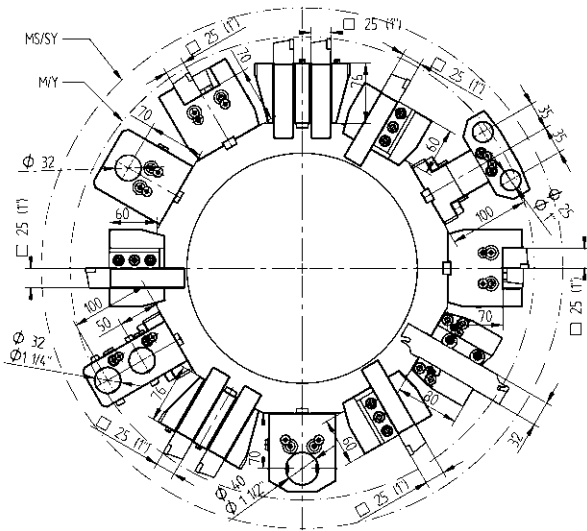



固定刀座 - 标准产品目录 (12刀位刀塔)

固定刀座 - 标准产品目录 (12刀位刀塔)

- 

车端面 and 车削刀座
25 48-87097
- 

车端面 and 车削刀座, HP-IC
25 48-87097-HP IC 80 bar
- 

车端面 and 车削刀座, 两侧的
25 48-87099
- 

车端面 and 车削刀座, 两侧的, HP-IC
25 48-87099-HP IC 80 bar
- 

车端面 and 镗削刀座
25 48-87101
- 

车端面 and 镗削刀座, HP-IC
25 48-87101-HP IC 80 bar
- 

组合刀座, LF=70
Ø 32 48-106897 IC 80 bar
Ø 40 48-87103 IC 80 bar

- 

镗刀刀座, 2刀位
Ø 32 48-87149
- 

防护板
48-87111

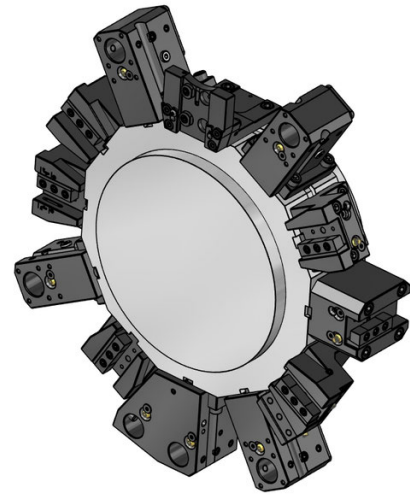
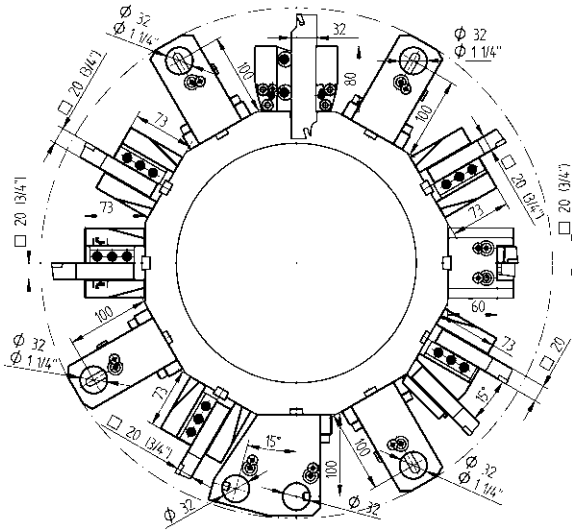

固定刀座 - 标准产品目录 (24刀位刀塔)

固定刀座 - 标准产品目录 (24刀位刀塔)



车端面 and 车削刀座

20 48-92036



车端面 and 车削刀座, HP-IC

20 48-92036-HP IC 80 bar



车端面 and 车削刀座, 两侧的

20 48-92038



车端面 and 车削刀座, 两侧的, HP-IC

20 48-92038-HP IC 80 bar



车端面 and 镗削刀座

20 48-92045



车端面 and 镗削刀座, HP-IC

20 48-92045-HP IC 80 bar



组合刀座, 通用的, LF=100

Ø 32 48-92043 IC 80 bar



241132016 ER25



241132020 ER32



镗刀刀座, 2刀位

Ø 32 48-87149



防护板

48-87111

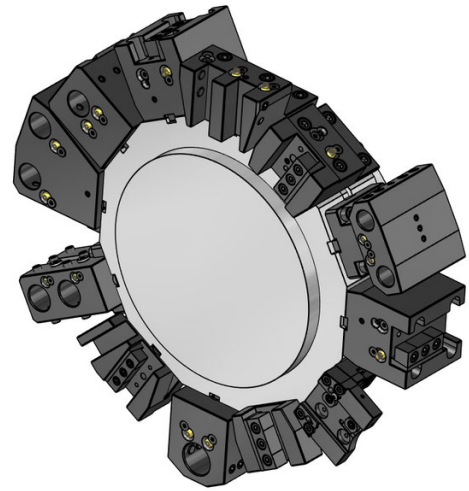
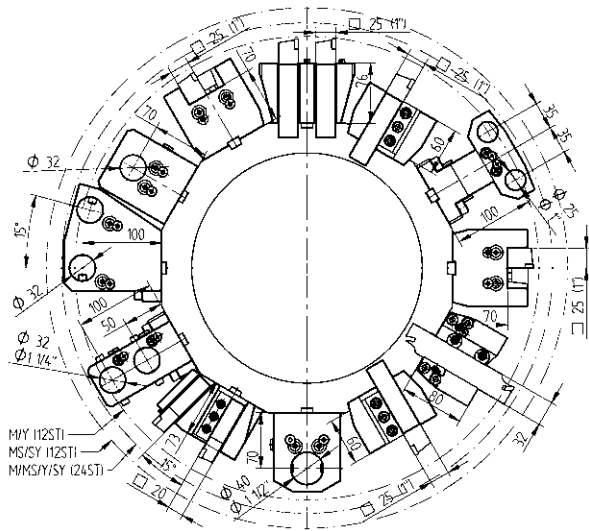

固定刀座 - 扩展产品目录

固定刀座 - 扩展产品目录



20

车端面 and 车削刀座, 2刀位, 24站位
48-92069 EC



Ø 32

镗刀刀座, 2刀位, 24站位
48-92073



20

车端面 and 车削刀座, 两侧的, 2刀位, 24站位
48-92071



25(1")

车端面 and 车削刀座, 2刀位, Y-轴
48-87140



25(1")

车端面 and 车削刀座, 两侧的, 2刀位, Y-轴
48-87141



SH 32

切断刀用刀座, 可调节的
48-103287



SH 32

切断刀用刀座, 可调节的, 内部切削液供应, HP-IC
48-110160R IC 80 bar
48-110160L IC 80 bar



Ø 25

镗刀刀座, 两侧的, 2刀位, Y-轴
48-87147

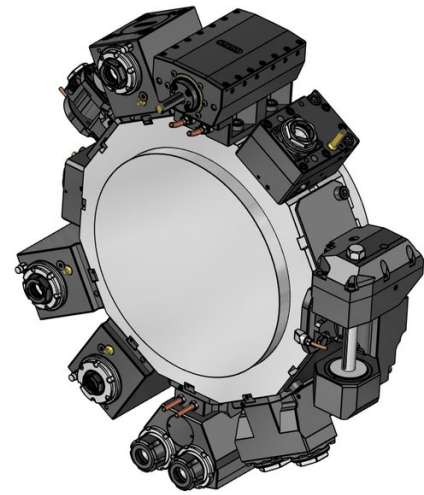
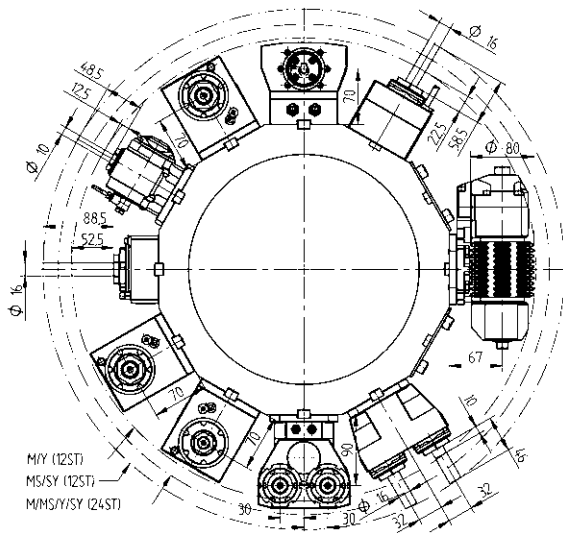

动力刀座 - QuickFlex®



直结式钻/铣动力刀座

- | | | | |
|----------|--------------|-----|-----------|
| ER-25 QF | 420125015-55 | 1:1 | EC |
| | 0067725000 | | |
| ER-25 QF | 420125016-55 | 1:1 | IC 80 bar |
| | 0067725000 | | |



直角式钻/铣动力刀座, LF=70

- | | | | |
|----------|--------------|-----|-----------|
| ER-25 QF | 420525015-55 | 1:1 | EC |
| | 0067725000 | | |
| ER-25 QF | 420525016-55 | 1:1 | IC 80 bar |
| | 0067725000 | | |



直角式钻/铣动力刀座, 两侧的, LF=70

- | | | | |
|----------|--------------|-----|----|
| ER-25 QF | 420525017-55 | 1:1 | EC |
| | 0067725000 | | |

动力刀座 - 扩展产品目录



直结式钻/铣动力刀座

- | | | | |
|-------|--------------|-----|-----------|
| ER 32 | 410120010-55 | 1:1 | EC |
| | 0067725000 | | |
| ER 32 | 410120011-55 | 1:1 | IC 80 bar |
| | 0067725000 | | |



直结式铣刀座 - 组合铣刀心轴, DIN6358

- | | | | |
|------|--------------|-----|----|
| Ø 22 | 410222004-55 | 1:1 | EC |
| | 00675000483 | | |



直结偏位式钻/铣动力刀座

- | | | | |
|-------|--------------|-----|-----------|
| ER 25 | 410116029-55 | 1:1 | EC |
| | 00675000932 | | |
| ER 25 | 410116030-55 | 1:1 | IC 80 bar |
| | 00675000932 | | |
| ER 20 | 410113009-55 | 1:2 | EC |
| | 00675000939 | | |
| ER 20 | 410113010-55 | 1:2 | IC 80 bar |
| | 00675000939 | | |
| ER 16 | 410410004-55 | 1:3 | EC |
| | 00675000937 | | |
| ER 16 | 410410005-55 | 1:3 | IC 80 bar |
| | 00675000937 | | |

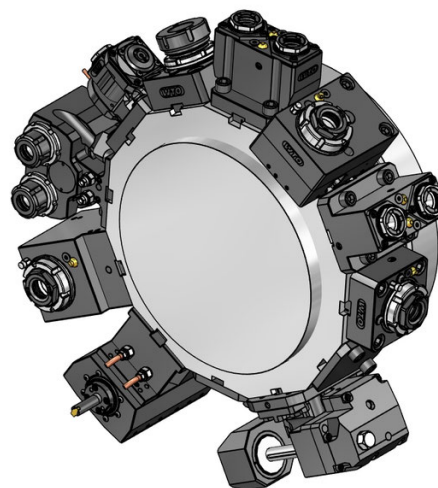
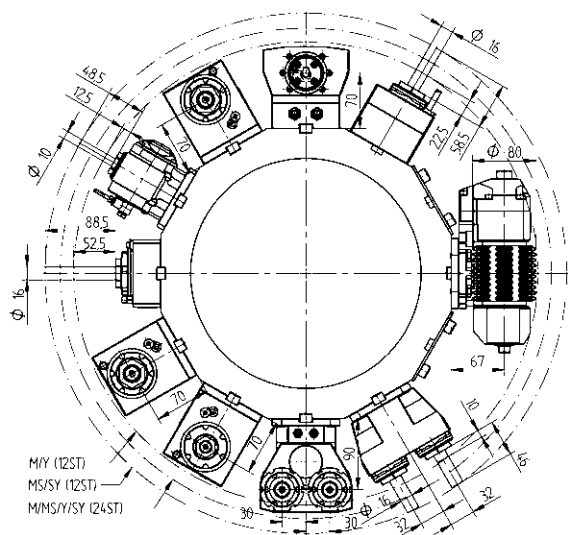

动力刀座 - 扩展产品目录



直角式钻/铣动力刀座, LF=70

ER 32	410520033-55 0067725000	1:1	EC
ER 32	410520034-55 0067725000	1:1	IC 80 bar
ER-20 QF	420520012-55 0067720001	1:2	EC
ER-20 QF	420520013-55 0067720001	1:2	IC 80 bar
ER 16	410810016-55 00675000841	1:3	EC
ER 16	410810017-55 00675000841	1:3	IC 80 bar
ER-25 QF	420525030-55 0067725000	2:1	EC
ER-25 QF	420525031-55 0067725000	2:1	IC 80 bar



直角式铣动力刀座 - 铣刀心轴, DIN6358, LF=70

Ø 22	410622010-55 00675000483	1:1	EC
------	-----------------------------	-----	----



直角后缩式钻/铣动力刀座

ER 25	410516024-55 00675000801	1:1	EC
ER 25	410516025-55 00675000801	1:1	IC 80 bar

动力刀座 - 扩展产品目录



可调角度钻/铣动力刀座

ER 16	411010005-55 00675000902	1:1	EC
ER 16	411010006-55 00675000902	1:1	IC 80 bar
ER 11	411007007-55 00675000914	1:2	EC
ER 11	411007008-55 00675000914	1:2	IC 80 bar



滚齿刀座

16-1 型式	411500002-55	1:1	EC
16-1 型式	411500001-55 00675000927	2:1	EC
	160016161 Ø 16		
	160022161 Ø 22		
	160027161 Ø 27		
	160015161 Ø 5/8"		
	160019161 Ø 3/4"		
	160025161 Ø 1"		
	160031161 Ø 1 1/4"		
	110587		

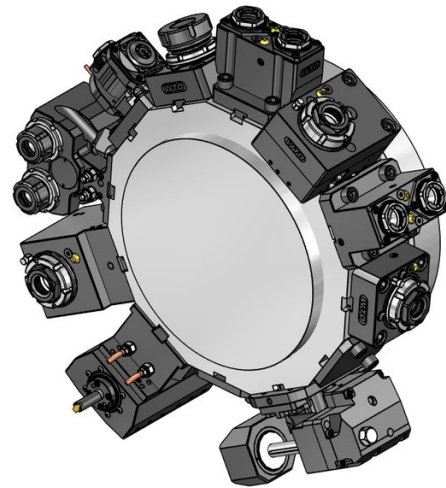
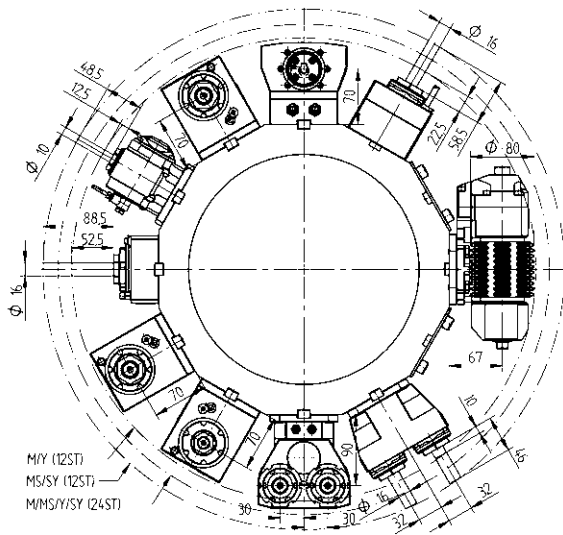

动力刀座 - 扩展产品目录

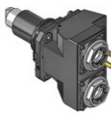

直结式钻/铣刀座, 2刀位, Y-轴

ER 25	413002004-55	1:1	EC
	00675000970		
ER 25	413002003-55	1:1	IC 80 bar
	00675000970		

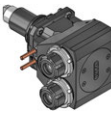

二轴直角式钻/铣动力刀座, Y-轴

ER 25	413502007-55	1:1	EC
	00675000915		
ER 25	413502008-55	1:1	IC 80 bar
	00675000915		



二轴直角式钻/铣动力刀座, 两侧的, Y-轴

ER 25	413502006-55	1:1	EC
	00675000915		

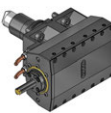

插槽刀座(内外径通用)

32 型式	414532001-55	1:1	EC
52 型式	414552000-55	1:1	EC

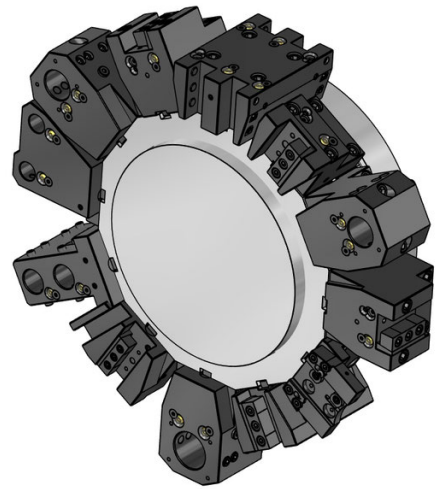
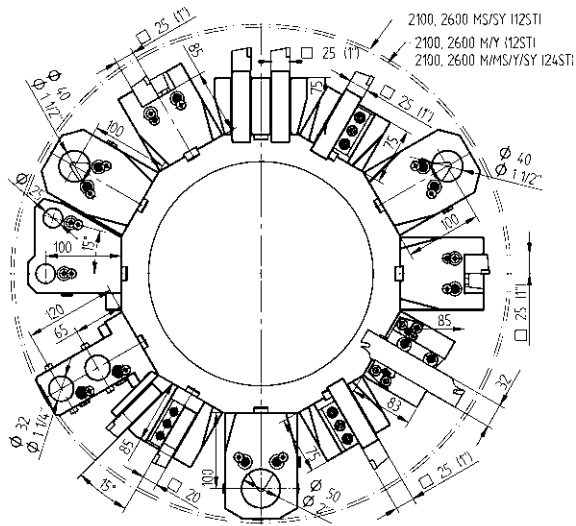

固定刀座 - 标准产品目录

固定刀座 - 标准产品目录



25 车端面 and 车削刀座

48-92428



25 车端面 and 车削刀座, HP-IC

48-92428-HP IC 80 bar



25 车端面 and 车削刀座, 两侧的

48-92438



25 车端面 and 车削刀座, 两侧的, HP-IC

48-92438-HP IC 80 bar



25 车端面 and 镗削刀座, 长型

48-92958



Ø 40 组合刀座, LF=100

48-92397 IC 80 bar

241140020 ER32

241140026 ER40

Ø 50 48-92467

IC 80 bar



Ø 32 镗刀刀座, 两侧的

48-101033



Ø 32 镗刀刀座, 2刀位

48-84524



防护板

48-87089

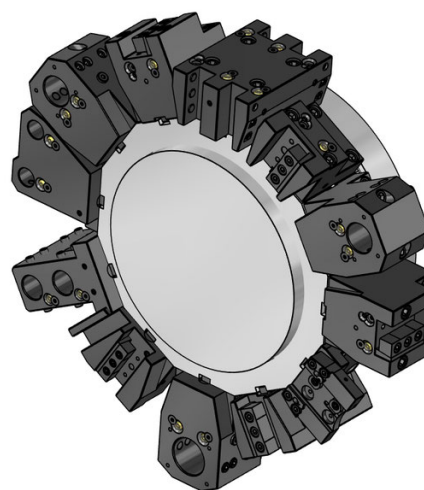
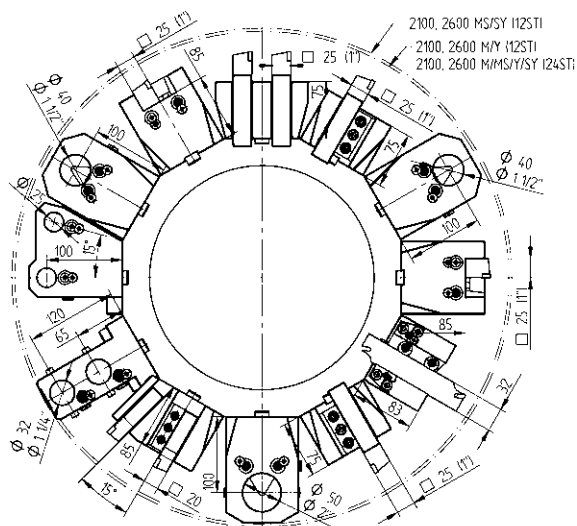

固定刀座 - 扩展产品目录

固定刀座 - 扩展产品目录



25

车端面 and 车削刀座, 短型
 48-86991



25

车端面 and 车削刀座, 短型, HP-IC
 48-86991-HP IC 80 bar



25

车端面 and 车削刀座, 长型
 48-86711

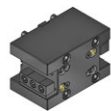

25

车端面 and 车削刀座, 两侧的, 长型
 48-84523



20

车端面 and 车削刀座, 2刀位, 24站位
 48-92089



20

车端面 and 车削刀座, 两侧的, 2刀位, 24站位
 48-92091



25(1")

车端面 and 车削刀座, 2刀位, Y-轴
 48-86103



25(1")

车端面 and 车削刀座, 两侧的, 2刀位, Y-轴
 48-86150



SH 32

切断刀用刀座, 可调节的
 48-99060



SH 32

切断刀用刀座, 可调节的, 内部切削液供应, HP-IC
 48-102256R IC 80 bar
 48-102256L IC 80 bar



Ø 25

镗刀刀座, 2刀位, 24站位
 48-92102



Ø 25

组合刀座, 两侧的, 2刀位, 24站位
 48-109092



Ø 50

镗刀刀座, 带槽, LF=100
 48-119005 EC



Ø 32

镗刀刀座, 2刀位, 两侧的
 48-86160

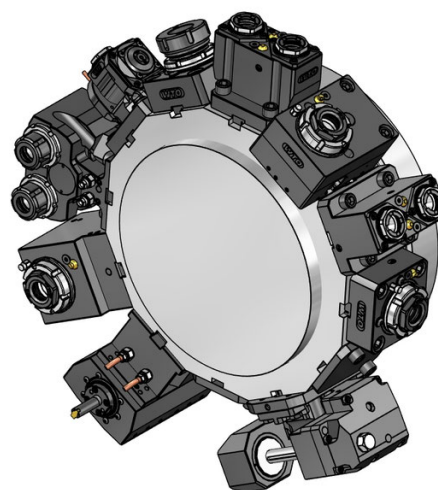
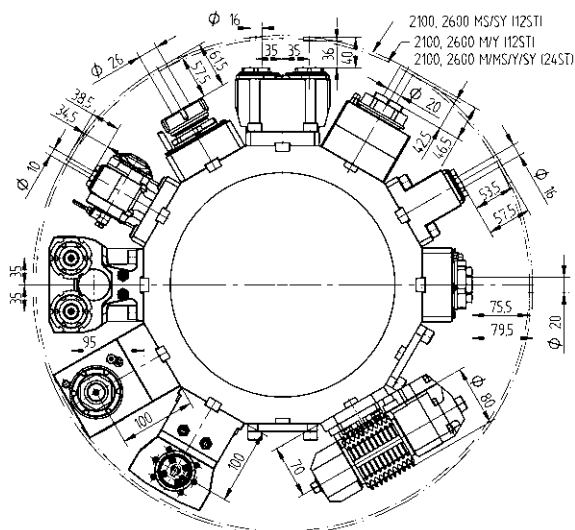

动力刀座 - QuickFlex®

动力刀座 - 扩展产品目录



直结式钻/铣动力刀座

ER-32 QF	QF32-DNE-BT65A-058-E-A	1:1	EC
	0067732000		
ER-32 QF	QF32-DNE-BT65A-060-I-A	1:1	IC 100 bar
	0067732000		



直结式钻/铣动力刀座 - QF smart (EU, US, CA, JP)

ER-32 QF	QF32-DNE-BT65A-060-I-SB-A	1:1	IC 100 bar
	0067732000		

LI-F12-01



直角式钻/铣动力刀座, LF=100

ER-32 QF	420532018-65	1:1	EC
	0067732000		
ER-32 QF	QF32-DNI-BT65A-100-I-A	1:1	IC 100 bar
	0067732000		



直角式钻/铣动力刀座 - QF smart (EU, US, CA, JP), LF=100

ER-32 QF	QF32-DNI-BT65A-100-I-SB-A	1:1	IC 100 bar
	0067732000		

LI-F12-01



直角式钻/铣动力刀座, 两侧的, LF=100

ER-32 QF	420532020-65	1:1	EC
	0067732000		



直结式钻/铣动力刀座

ER 40	ER40-DNE-BT65A-084-E-A	1:1	EC
	00675000079		
ER 40	ER40-DNE-BT65A-086-I-A	1:1	IC 100 bar
	00675000079		



直结偏位式钻/铣动力刀座

ER-32 QF	420132037-65	1:1	EC
	0067732000		
ER-32 QF	420132038-65	1:1	IC 80 bar
	0067732000		
ER-25 QF	420125010-65	1:2	EC
	0067725001		
ER-25 QF	420125011-65	1:2	IC 80 bar
	0067725001		



直角式钻/铣动力刀座, LF=100

ER 40	410526007-65	1:1	EC
	00675000079		
ER 40	410526008-65	1:1	IC 80 bar
	00675000079		

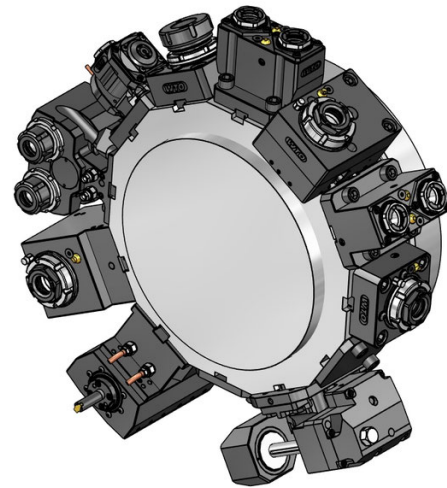
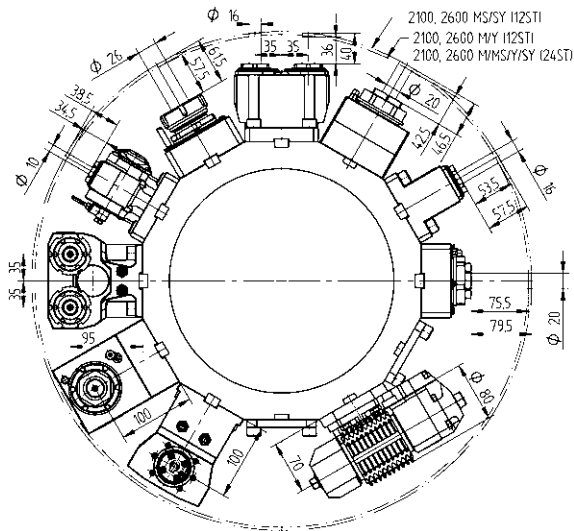

动力刀座 - 扩展产品目录

动力刀座 - 扩展产品目录



直角式钻/铣动力刀座, LF=100

ER-25 QF	QF25-DNI-BT65A-100-E-S-A	1:2	EC
	0067725001		
ER-25 QF	QF25-DNI-BT65A-100-I-S-A	1:2	IC 100 bar
	0067725001		
ER-32 QF	QF32-DNI-BT65A-100-E-T-A	2:1	EC
	0067732000		
ER-32 QF	QF32-DNI-BT65A-100-I-T-A	2:1	IC 100 bar
	0067732000		



直角后缩式钻/铣动力刀座

ER-32 QF	420532090-65	1:1	EC
	0067732000		
ER-32 QF	420532091-65	1:1	IC 80 bar
	0067732000		



可调角度钻/铣动力刀座

ER 16	411010002-65	1:1	EC
	00675000902		
ER 16	411010003-65	1:1	IC 80 bar
	00675000902		
ER 11	411007002-65	1:2	EC
	00675000914		
ER 11	411007003-65	1:2	IC 80 bar
	00675000914		



滚齿刀座

16-1 型式	411500003-65	1:1	EC
16-1 型式	411500002-65	2:1	EC
	00675000927		
	160016161 Ø 16		
	160022161 Ø 22		
	160027161 Ø 27		
	160015161 Ø 5/8"		
	160019161 Ø 3/4"		
	160025161 Ø 1"		
	160031161 Ø 1 1/4"		
	110587		



直结式钻/铣刀座, 两侧的

ER 25	413002005-65	1:1	EC
	00675000907		



直结式钻/铣刀座, 2刀位, Y-轴

ER 25	413002004-65	1:1	EC
	00675000907		

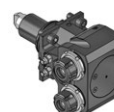

二轴直角式钻/铣动力刀座, Y-轴

ER 25	413502006-65	1:1	EC
	00675000915		
ER 25	413502007-65	1:1	IC 80 bar
	00675000915		

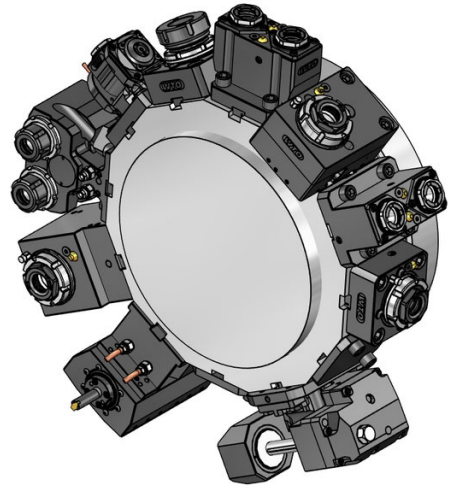
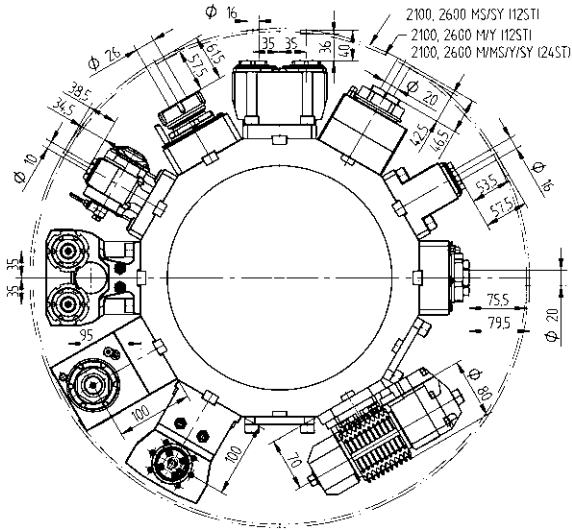

动力刀座 - 扩展产品目录



二轴直角式钻/铣动力刀座, 两侧的, Y-轴

ER 25 413502008-65 1:1 EC
 00675000915

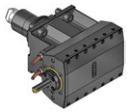

插槽刀座(内外径通用)

32 型式 414532000-65 1:1 EC



插槽刀座(内外径通用)

52 型式 414552000-65 1:1 EC

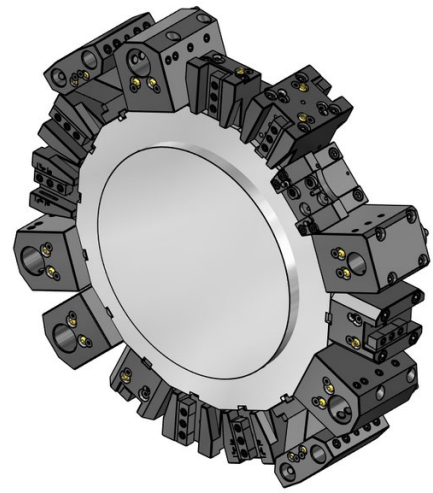
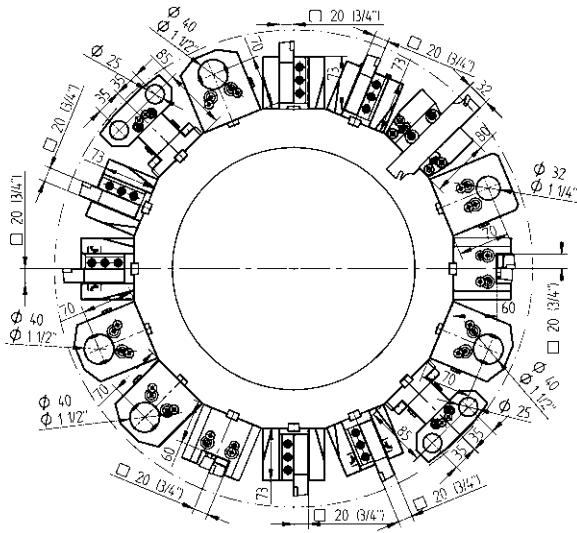

固定刀座 - 标准产品目录

固定刀座 - 标准产品目录



20

车端面 and 车削刀座
48-92036



20

车端面 and 车削刀座, HP-IC
48-92036-HP IC 80 bar



20

车端面 and 车削刀座, 两侧的
48-92038



20

车端面 and 车削刀座, 两侧的, HP-IC
48-92038-HP IC 80 bar



20

车端面 and 镗削刀座
48-92045



20

车端面 and 镗削刀座, HP-IC
48-92045-HP IC 80 bar



Ø 32

组合刀座, LF=70
48-106897 IC 80 bar

Ø 40

48-87103 IC 80 bar



48-87111

防护板

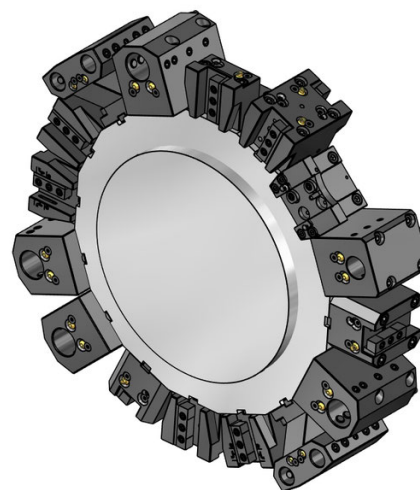
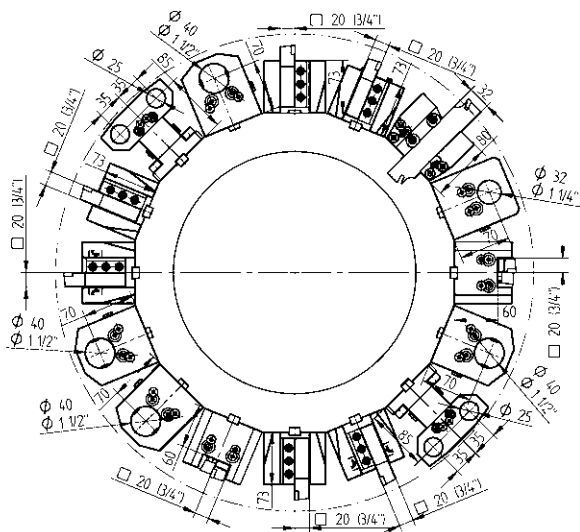

固定刀座 - 扩展产品目录



SH 32

切断刀用刀座, 可调节的

48-103287



SH 32

切断刀用刀座, 可调节的, 内部切削液供应, HP-IC

SH 32

48-110160R

IC 80 bar

48-110160L

IC 80 bar



Ø 25

镗刀刀座, 两侧的, 2刀位, Y-轴, 短型

48-98353

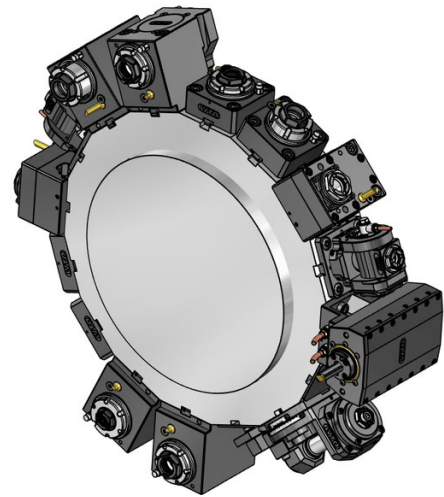
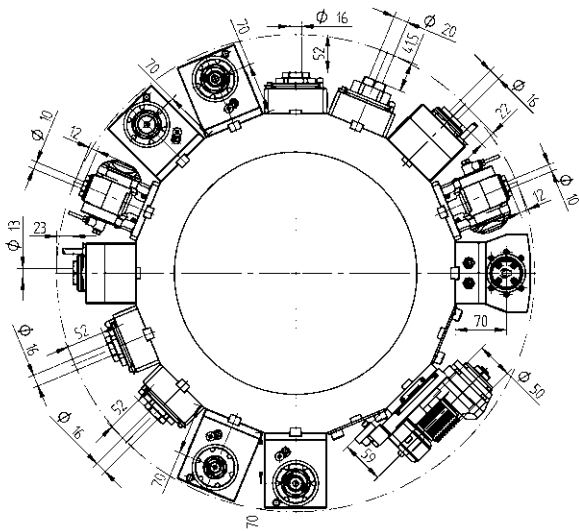

动力刀座 - QuickFlex®



直结式钻/铣动力刀座

ER-25 QF 420125015-55 1:1 EC
 0067725000

ER-25 QF 420125016-55 1:1 IC 80 bar
 0067725000



直角式钻/铣动力刀座, LF=70

ER-25 QF 420525015-55 1:1 EC
 0067725000

ER-25 QF 420525016-55 1:1 IC 80 bar
 0067725000



直角式钻/铣动力刀座, 两侧的, LF=70

ER-25 QF 420525017-55 1:1 EC
 0067725000

动力刀座 - 扩展产品目录



直结式钻/铣动力刀座

ER 32 410120010-55 1:1 EC
 0067725000

ER 32 410120011-55 1:1 IC 80 bar
 0067725000



直结式铣刀座 - 组合铣刀心轴, DIN6358

Ø 22 410222004-55 1:1 EC
 00675000483



直结偏位式钻/铣动力刀座

ER 25 410116029-55 1:1 EC
 00675000932

ER 25 410116030-55 1:1 IC 80 bar
 00675000932

ER 20 410113009-55 1:2 EC
 00675000939

ER 20 410113010-55 1:2 IC 80 bar
 00675000939

ER 16 410410004-55 1:3 EC
 00675000937

ER 16 410410005-55 1:3 IC 80 bar
 00675000937

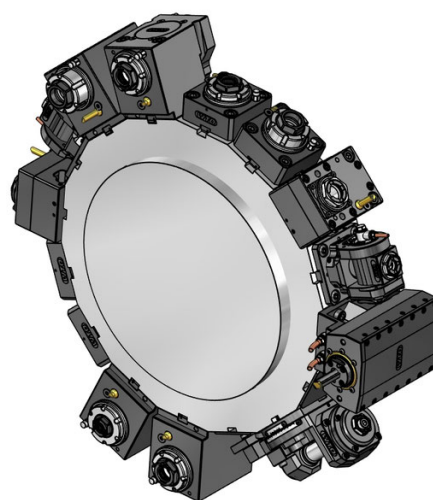
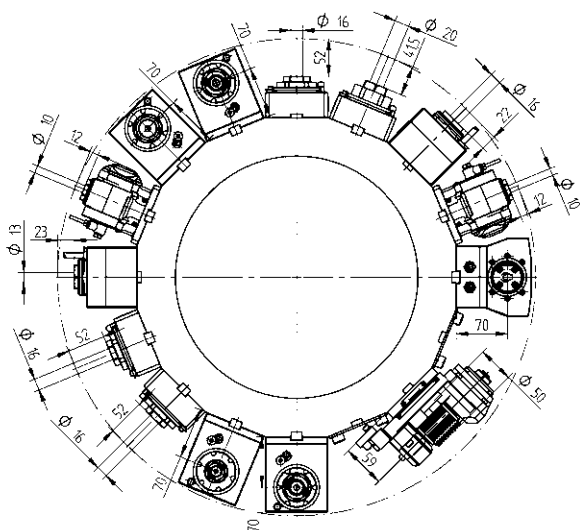

动力刀座 - 扩展产品目录



直角式钻/铣动力刀座, LF=70

ER 32	410520033-55	1:1	EC
	0067725000		
ER 32	410520034-55	1:1	IC 80 bar
	0067725000		
ER-20 QF	420520012-55	1:2	EC
	0067720001		
ER-20 QF	420520013-55	1:2	IC 80 bar
	0067720001		
ER 16	410810016-55	1:3	EC
	00675000841		
ER 16	410810017-55	1:3	IC 80 bar
	00675000841		
ER-25 QF	420525030-55	2:1	EC
	0067725000		
ER-25 QF	420525031-55	2:1	IC 80 bar
	0067725000		



直角式铣动力刀座 - 铣刀心轴, DIN6358, LF=70

Ø 22	410622010-55	1:1	EC
	00675000483		



直角后缩式钻/铣动力刀座

ER 25	410516024-55	1:1	EC
	00675000801		
ER 25	410516025-55	1:1	IC 80 bar
	00675000801		

动力刀座 - 扩展产品目录



可调角度钻/铣动力刀座

ER 16	411010005-55	1:1	EC
	00675000902		
ER 16	411010006-55	1:1	IC 80 bar
	00675000902		
ER 11	411007007-55	1:2	EC
	00675000914		
ER 11	411007008-55	1:2	IC 80 bar
	00675000914		



滚齿刀座

15-2 型式	410900002-55	1:1	EC
	00675001015		
	160008152 Ø 8		
	160010152 Ø 10		
	160013152 Ø 13		
	160016152 Ø 16		
	160022152 Ø 22		
	160015152 Ø 5/8"		
	160019152 Ø 3/4"		
	110587		

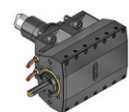

插槽刀座(内外径通用)

32 型式	414532001-55	1:1	EC
52 型式	414552000-55	1:1	EC

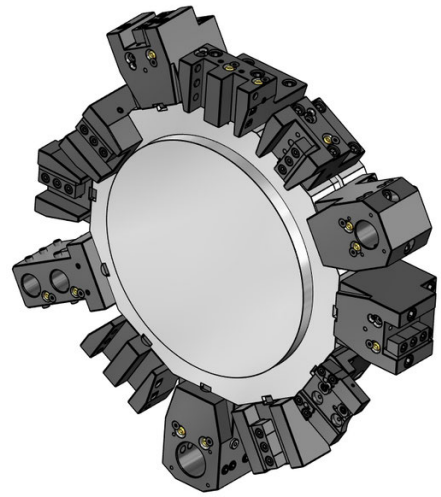
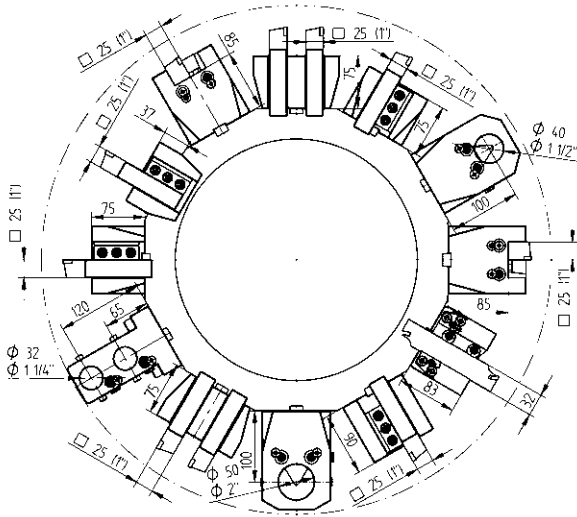

固定刀座 - 标准产品目录

固定刀座 - 标准产品目录



25

车端面 and 车削刀座
48-92428



25

车端面 and 车削刀座, HP-IC
48-92428-HP IC 80 bar



25

车端面 and 车削刀座, 两侧的
48-92438



25

车端面 and 车削刀座, 两侧的, HP-IC
48-92438-HP IC 80 bar



25

车端面 and 镗削刀座, 长型
48-92958



Ø 40

组合刀座, LF=100
48-92397 IC 80 bar

 241140020 ER32

 241140026 ER40

Ø 50

48-92467 IC 80 bar



Ø 32

镗刀刀座, 两侧的
48-101033



Ø 32

镗刀刀座, 2刀位
48-84524



48-87089

防护板

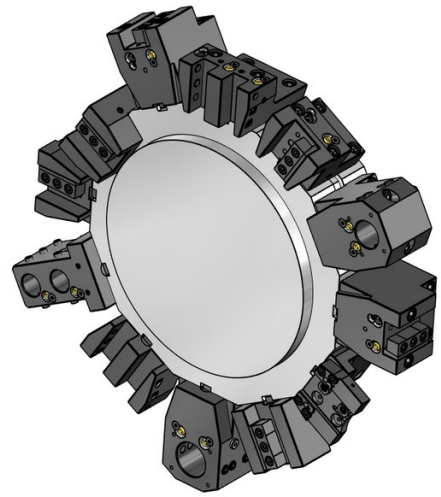
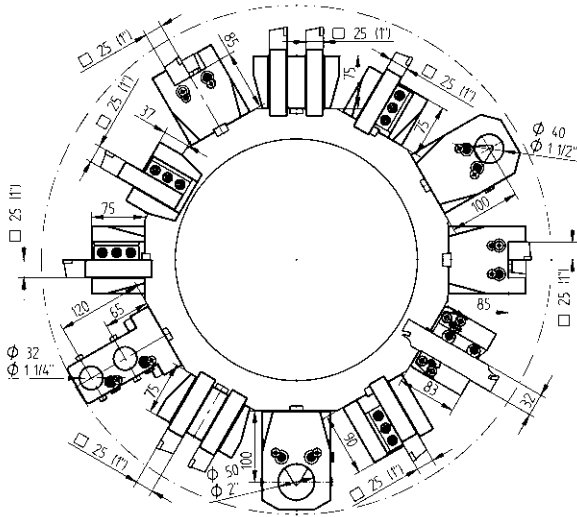

固定刀座 - 扩展产品目录



25 车端面 and 车削刀座, 短型

48-86991



25 车端面 and 车削刀座, 短型, HP-IC
48-86991-HP IC 80 bar



25 车端面 and 车削刀座, 长型
48-86711



25(1") 车端面 and 车削刀座, 2刀位, Y-轴
48-86103



25(1") 车端面 and 车削刀座, 两侧的, 2刀位, Y-轴
48-86150



SH 32 切断刀用刀座, 可调节的
48-99060



SH 32 切断刀用刀座, 可调节的, 内部切削液供应, HP-IC
SH 32 48-102256R IC 80 bar
SH 32 48-102256L IC 80 bar

固定刀座 - 扩展产品目录



SH 32 切断刀用刀座, 可调节的, 长型, 内部切削液供应, HP-IC

SH 32 48-100082R IC 80 bar
SH 32 48-100082L IC 80 bar



Ø 50 镗刀刀座, 带槽, LF=100
48-119005 EC

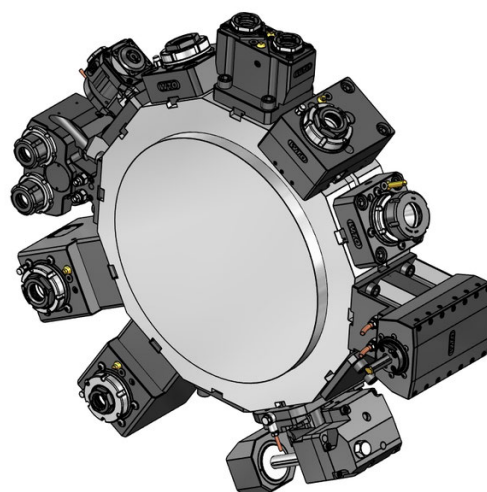
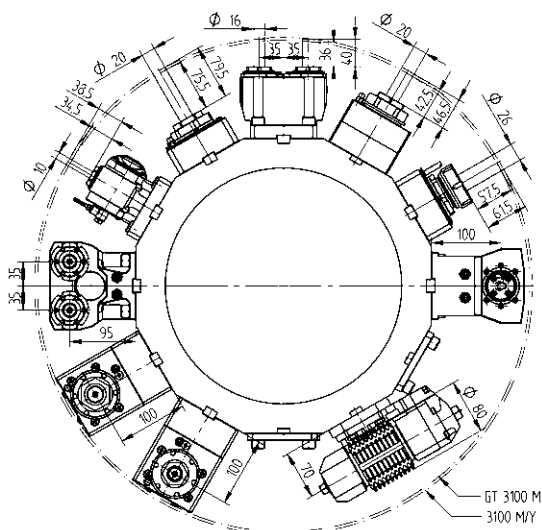

动力刀座 - QuickFlex®

动力刀座 - 扩展产品目录



直结式钻/铣动力刀座

ER-32 QF	QF32-DNE-BT65A-058-E-A	1:1	EC
	0067732000		
ER-32 QF	QF32-DNE-BT65A-060-I-A	1:1	IC 100 bar
	0067732000		



直结式钻/铣动力刀座 - QF smart (EU, US, CA, JP)

ER-32 QF	QF32-DNE-BT65A-060-I-SB-A	1:1	IC 100 bar
	0067732000		



LI-F12-01



直角式钻/铣动力刀座, LF=100

ER-32 QF	420532018-65	1:1	EC
	0067732000		
ER-32 QF	QF32-DNI-BT65A-100-I-A	1:1	IC 100 bar
	0067732000		



直角式钻/铣动力刀座 - QF smart (EU, US, CA, JP), LF=100

ER-32 QF	QF32-DNI-BT65A-100-I-SB-A	1:1	IC 100 bar
	0067732000		



LI-F12-01



直角式钻/铣动力刀座, 两侧的, LF=100

ER-32 QF	420532020-65	1:1	EC
	0067732000		



直结式钻/铣动力刀座

ER 40	ER40-DNE-BT65A-084-E-A	1:1	EC
	00675000079		
ER 40	ER40-DNE-BT65A-086-I-A	1:1	IC 100 bar
	00675000079		



直结偏位式钻/铣动力刀座

ER-32 QF	420132037-65	1:1	EC
	0067732000		
ER-32 QF	420132038-65	1:1	IC 80 bar
	0067732000		
ER-25 QF	420125010-65	1:2	EC
	0067725001		
ER-25 QF	420125011-65	1:2	IC 80 bar
	0067725001		



直角式钻/铣动力刀座, LF=100

ER 40	410526007-65	1:1	EC
	00675000079		
ER 40	410526008-65	1:1	IC 80 bar
	00675000079		

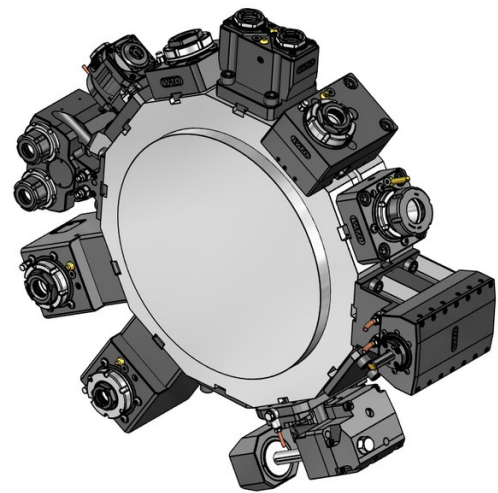
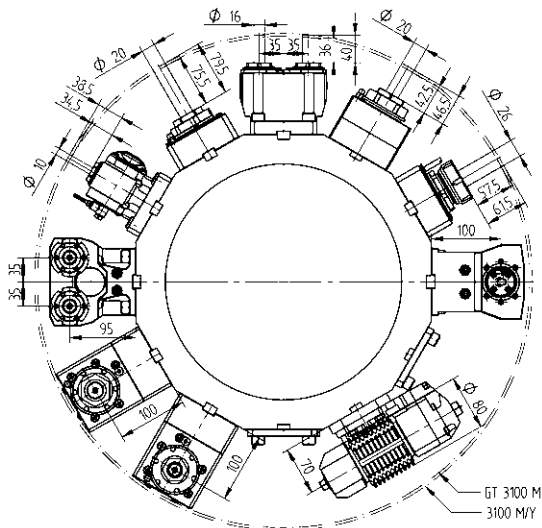

动力刀座 - 扩展产品目录

动力刀座 - 扩展产品目录



直角式钻/铣动力刀座, LF=100

ER-25 QF	QF25-DNI-BT65A-100-E-S-A 0067725001	1:2	EC
ER-25 QF	QF25-DNI-BT65A-100-I-S-A 0067725001	1:2	IC 100 bar
ER-32 QF	QF32-DNI-BT65A-100-E-T-A 0067732000	2:1	EC
ER-32 QF	QF32-DNI-BT65A-100-I-T-A 0067732000	2:1	IC 100 bar



直角后缩式钻/铣动力刀座

ER-32 QF	420532090-65 0067732000	1:1	EC
ER-32 QF	420532091-65 0067732000	1:1	IC 80 bar



可调角度钻/铣动力刀座

ER 16	411010002-65 00675000902	1:1	EC
ER 16	411010003-65 00675000902	1:1	IC 80 bar
ER 11	411007002-65 00675000914	1:2	EC
ER 11	411007003-65 00675000914	1:2	IC 80 bar



滚齿刀座

16-1 型式	411500003-65	1:1	EC
16-1 型式	411500002-65	2:1	EC
	00675000927		
	160016161 Ø 16		
	160022161 Ø 22		
	160027161 Ø 27		
	160015161 Ø 5/8"		
	160019161 Ø 3/4"		
	160025161 Ø 1"		
	160031161 Ø 1 1/4"		
	110587		



直结式钻/铣刀座, 2刀位, Y-轴

ER 25	413002004-65 00675000907	1:1	EC
-------	-----------------------------	-----	----

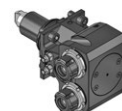

二轴直角式钻/铣动力刀座, Y-轴

ER 25	413502006-65 00675000915	1:1	EC
ER 25	413502007-65 00675000915	1:1	IC 80 bar

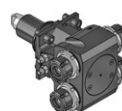

二轴直角式钻/铣动力刀座, 两侧的, Y-轴

ER 25	413502008-65 00675000915	1:1	EC
-------	-----------------------------	-----	----

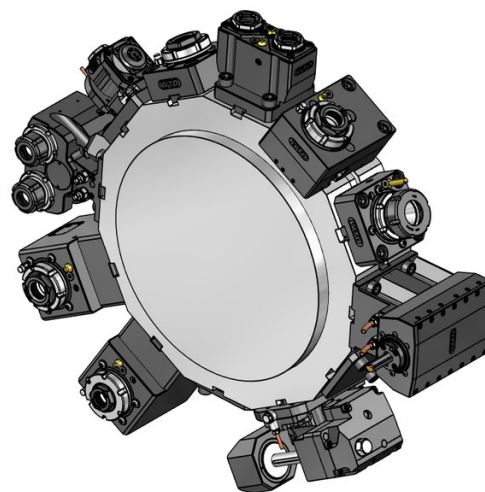
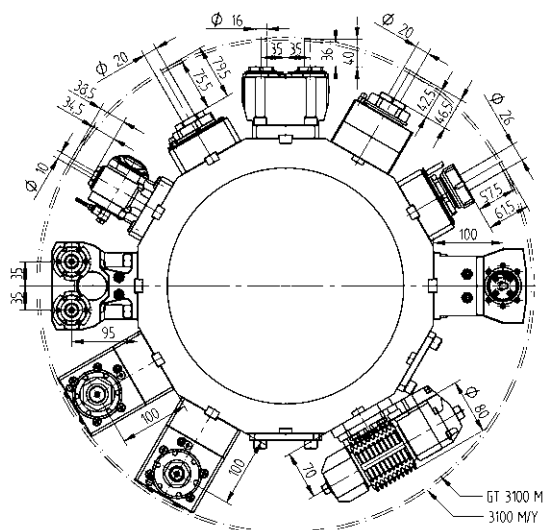

动力刀座 - 扩展产品目录



插槽刀座(内外径通用)

32 型式

414532000-65

1:1

EC



插槽刀座(内外径通用)

52 型式

414552000-65

1:1

EC

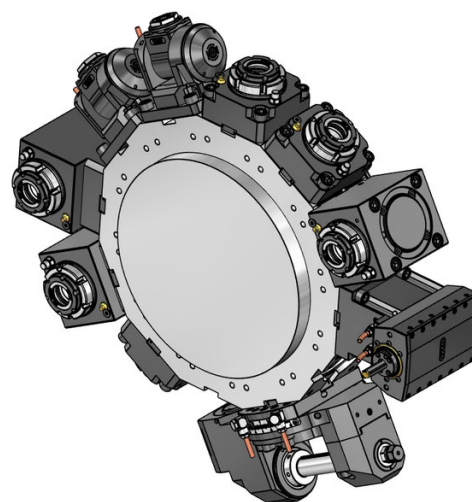
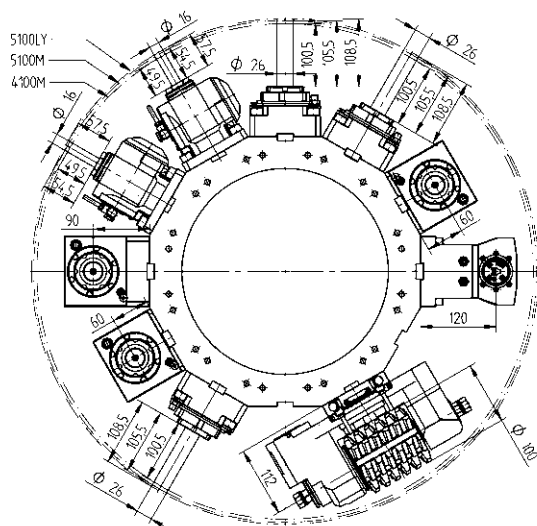

动力刀座 - QuickFlex®



直结式钻/铣动力刀座

- | | | | |
|----------|--------------|-----|-----------|
| ER-40 QF | 420140015-75 | 1:1 | EC |
| | 0067740000 | | |
| ER-40 QF | 420140016-75 | 1:1 | IC 80 bar |
| | 0067740000 | | |



直角式钻/铣动力刀座, LF=60

- | | | | |
|----------|--------------|-----|-----------|
| ER-40 QF | 420540015-75 | 1:1 | EC |
| | 0067740000 | | |
| ER-40 QF | 420540016-75 | 1:1 | IC 80 bar |
| | 0067740000 | | |



直角式钻/铣动力刀座, LF=90

- | | | | |
|----------|--------------|-----|-----------|
| ER-40 QF | 420540017-75 | 1:1 | EC |
| | 0067740000 | | |
| ER-40 QF | 420540018-75 | 1:1 | IC 80 bar |
| | 0067740000 | | |

动力刀座 - 扩展产品目录



直角式钻/铣动力刀座, LF=60

- | | | | |
|----------|--------------|-----|-----------|
| ER-32 QF | 420532010-75 | 1:2 | EC |
| | 0067732001 | | |
| ER-32 QF | 420532011-75 | 1:2 | IC 80 bar |
| | 0067732001 | | |
| ER-40 QF | 420540021-75 | 2:1 | EC |
| | 0067740000 | | |
| ER-40 QF | 420540022-75 | 2:1 | IC 80 bar |
| | 0067740000 | | |



可调角度钻/铣动力刀座

- | | | | |
|-------|--------------|-----|-----------|
| ER 25 | 411016000-75 | 1:1 | EC |
| | 00675000934 | | |
| ER 25 | 411016001-75 | 1:1 | IC 80 bar |
| | 00675000934 | | |
| ER 16 | 411010002-75 | 1:2 | EC |
| | 00675000936 | | |
| ER 16 | 411010003-75 | 1:2 | IC 80 bar |
| | 00675000936 | | |

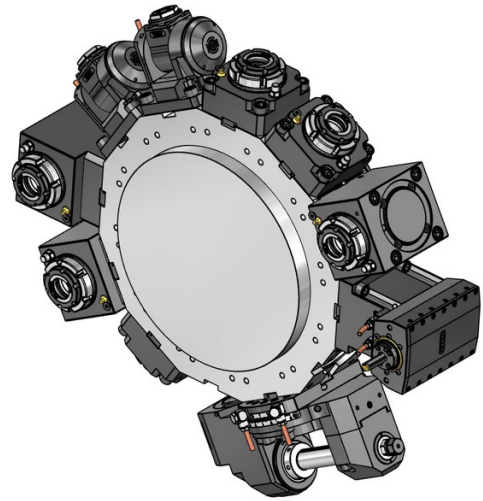
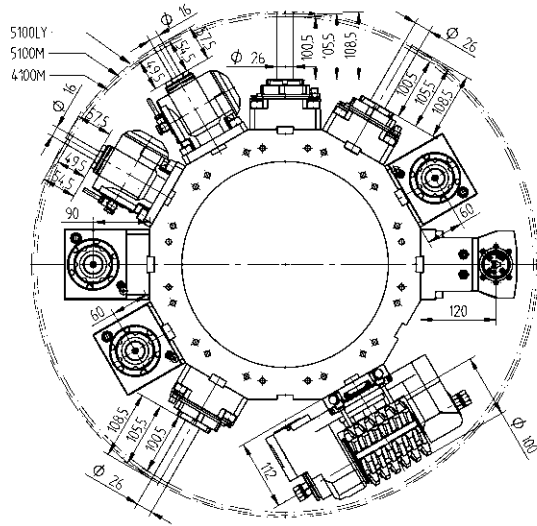

动力刀座 - 扩展产品目录



滚齿刀座

- | | | | |
|---------|--------------------|-----|----|
| C5-1 型式 | 410900001-75 | 2:1 | EC |
| | 00675001008 | | |
| | 160022C51 Ø 22 | | |
| | 160027C51 Ø 27 | | |
| | 160032C51 Ø 32 | | |
| | 160015C51 Ø 5/8" | | |
| | 160019C51 Ø 3/4" | | |
| | 160025C51 Ø 1" | | |
| | 160031C51 Ø 1 1/4" | | |
| | 110587 | | |



插槽刀座(内外径通用)

- | | | | |
|-------|--------------|-----|----|
| 32 型式 | 414532000-75 | 1:1 | EC |
| 52 型式 | 414552000-75 | 1:1 | EC |

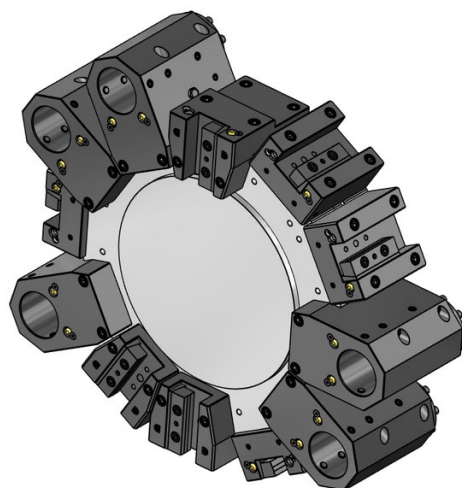
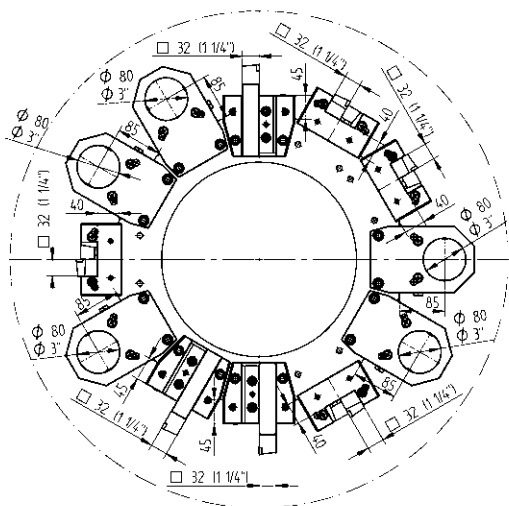

固定刀座 - 标准产品目录



32

车端面 and 车削刀座

48-95667



32

车端面 and 镗削刀座

48-95669



$\phi 80$

组合刀座

48-95671

IC 80 bar

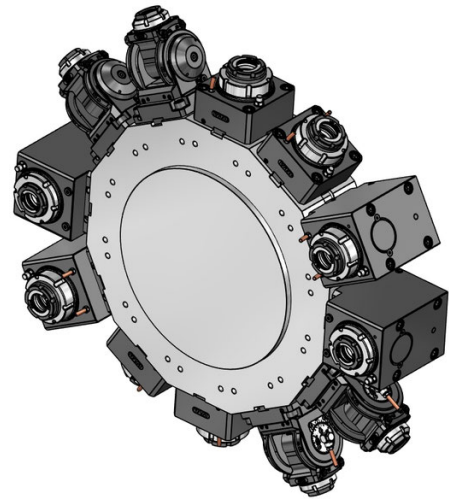
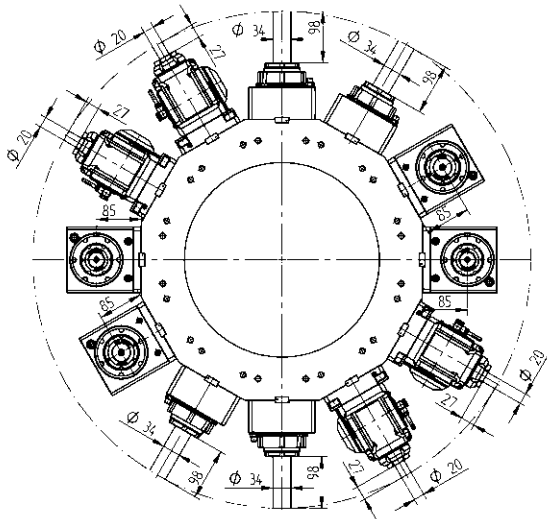

动力刀座 - QuickFlex®

动力刀座 - 扩展产品目录



直结式钻/铣动力刀座

- | | | | |
|----------|--------------|-----|-----------|
| ER-50 QF | 420150015-85 | 1:1 | EC |
| | 0067750000 | | |
| ER-50 QF | 420150016-85 | 1:1 | IC 80 bar |
| | 0067750000 | | |



直角式钻/铣动力刀座, LF=85

- | | | | |
|----------|--------------|-----|-----------|
| ER-40 QF | 420540015-85 | 1:2 | EC |
| | 0067740001 | | |
| ER-40 QF | 420540016-85 | 1:2 | IC 80 bar |
| | 0067740001 | | |



直角式钻/铣动力刀座, LF=85

- | | | | |
|----------|--------------|-----|-----------|
| ER-50 QF | 420550015-85 | 1:1 | EC |
| | 0067750000 | | |
| ER-50 QF | 420550016-85 | 1:1 | IC 80 bar |
| | 0067750000 | | |



可调角度钻/铣动力刀座

- | | | | |
|----------|--------------|-----|-----------|
| ER-32 QF | 421032010-85 | 1:1 | EC |
| | 00675000976 | | |
| ER-32 QF | 421032011-85 | 1:1 | IC 80 bar |
| | 00675000976 | | |



滚齿刀座

- | | | | |
|---------|--------------------|-----|----|
| C5-1 型式 | 410900000-85 | 2:1 | EC |
| | 00675001008 | | |
| | 160022C51 Ø 22 | | |
| | 160027C51 Ø 27 | | |
| | 160032C51 Ø 32 | | |
| | 160019C51 Ø 3/4" | | |
| | 160025C51 Ø 1" | | |
| | 160031C51 Ø 1 1/4" | | |
| | 110587 | | |

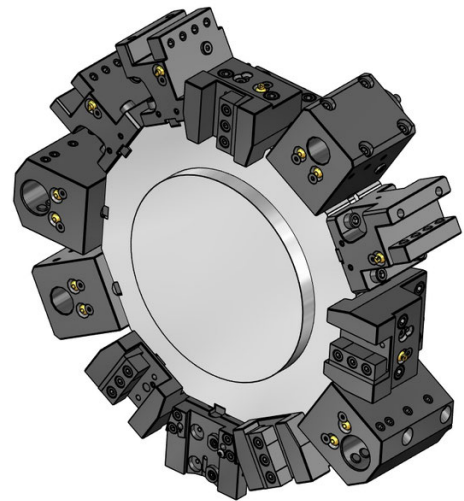
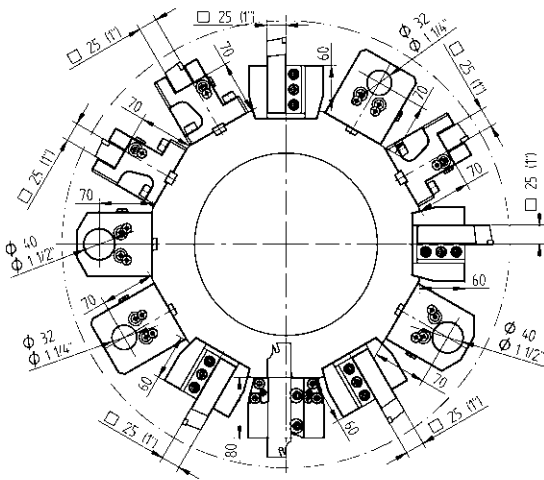

固定刀座 - 标准产品目录

固定刀座 - 扩展产品目录



车端面和车削刀座
48-87097

25



车端面和车削刀座, HP-IC
48-87097-HP

25

IC 80 bar



车端面 and 镗削刀座
48-87101

25



车端面 and 镗削刀座, HP-IC
48-87101-HP

25

IC 80 bar



组合刀座, LF=70

Ø 32

48-106897

IC 80 bar

Ø 40

48-87103

IC 80 bar



防护板

48-87111



切断刀用刀座, 可调节的

SH 32

48-103287



切断刀用刀座, 可调节的, 内部切削液供应, HP-IC

SH 32

48-110160R

IC 80 bar

SH 32

48-110160L

IC 80 bar

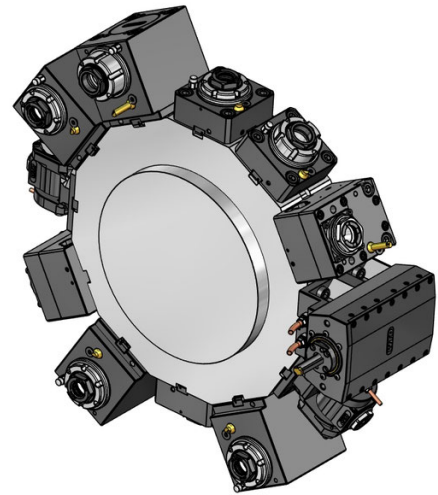
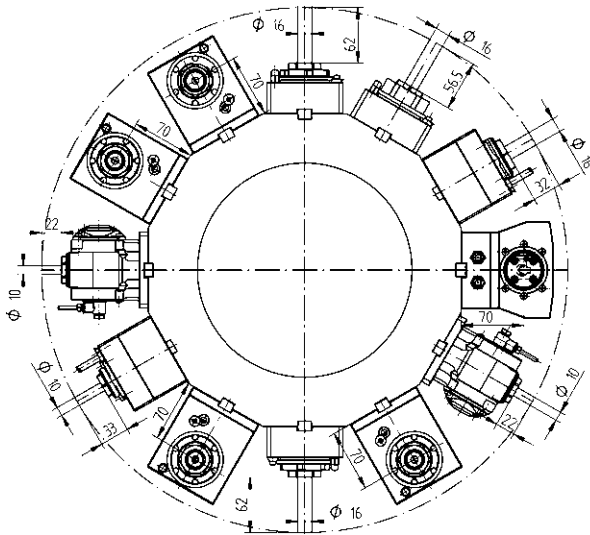

动力刀座 - QuickFlex®



直结式钻/铣动力刀座

- | | | | |
|----------|--------------|-----|-----------|
| ER-25 QF | 420125015-55 | 1:1 | EC |
| | 0067725000 | | |
| ER-25 QF | 420125016-55 | 1:1 | IC 80 bar |
| | 0067725000 | | |



直角式钻/铣动力刀座, LF=70

- | | | | |
|----------|--------------|-----|-----------|
| ER-25 QF | 420525015-55 | 1:1 | EC |
| | 0067725000 | | |
| ER-25 QF | 420525016-55 | 1:1 | IC 80 bar |
| | 0067725000 | | |

动力刀座 - 扩展产品目录



直结式钻/铣动力刀座

- | | | | |
|-------|--------------|-----|-----------|
| ER 32 | 410120010-55 | 1:1 | EC |
| | 0067725000 | | |
| ER 32 | 410120011-55 | 1:1 | IC 80 bar |
| | 0067725000 | | |



直结式铣刀座 - 组合铣刀心轴, DIN6358

- | | | | |
|------|--------------|-----|----|
| Ø 22 | 410222004-55 | 1:1 | EC |
| | 00675000483 | | |



直结偏位式钻/铣动力刀座

- | | | | |
|-------|--------------|-----|-----------|
| ER 25 | 410116029-55 | 1:1 | EC |
| | 00675000932 | | |
| ER 25 | 410116030-55 | 1:1 | IC 80 bar |
| | 00675000932 | | |
| ER 20 | 410113009-55 | 1:2 | EC |
| | 00675000939 | | |
| ER 20 | 410113010-55 | 1:2 | IC 80 bar |
| | 00675000939 | | |
| ER 16 | 410410004-55 | 1:3 | EC |
| | 00675000937 | | |
| ER 16 | 410410005-55 | 1:3 | IC 80 bar |
| | 00675000937 | | |

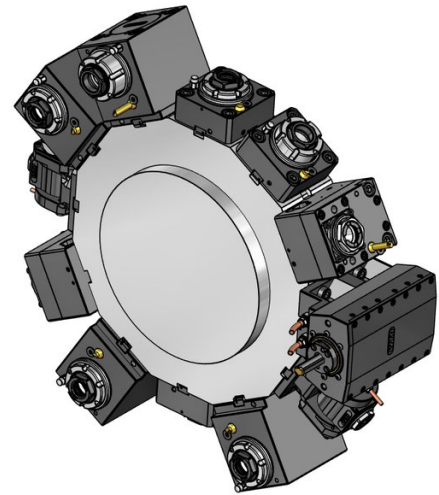
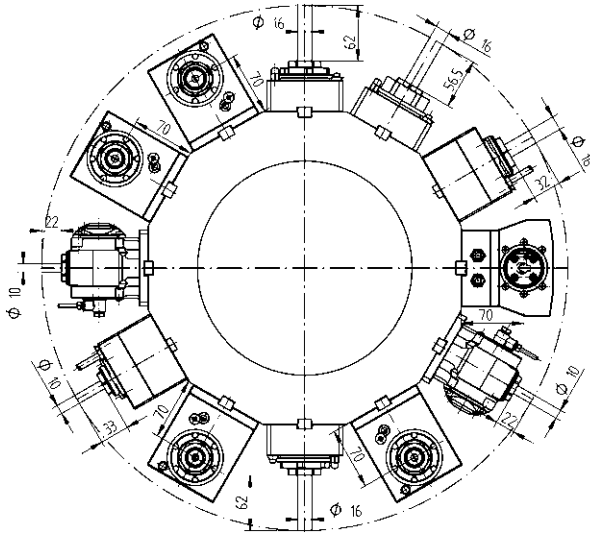

动力刀座 - 扩展产品目录



直角式钻/铣动力刀座, LF=70

ER 32	410520033-55 0067725000	1:1	EC
ER 32	410520034-55 0067725000	1:1	IC 80 bar
ER-20 QF	420520012-55 0067720001	1:2	EC
ER-20 QF	420520013-55 0067720001	1:2	IC 80 bar
ER 16	410810016-55 00675000841	1:3	EC
ER 16	410810017-55 00675000841	1:3	IC 80 bar
ER-25 QF	420525030-55 0067725000	2:1	EC
ER-25 QF	420525031-55 0067725000	2:1	IC 80 bar



直角式铣动力刀座 - 铣刀心轴, DIN6358, LF=70

Ø 22	410622010-55 00675000483	1:1	EC
------	-----------------------------	-----	----

动力刀座 - 扩展产品目录



可调角度钻/铣动力刀座

ER 16	411010005-55 00675000902	1:1	EC
ER 16	411010006-55 00675000902	1:1	IC 80 bar
ER 11	411007007-55 00675000914	1:2	EC
ER 11	411007008-55 00675000914	1:2	IC 80 bar



插槽刀座(内外径通用)

32 型式	414532001-55	1:1	EC
52 型式	414552000-55	1:1	EC

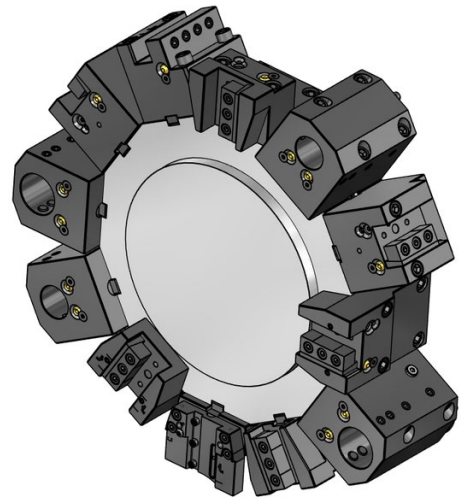
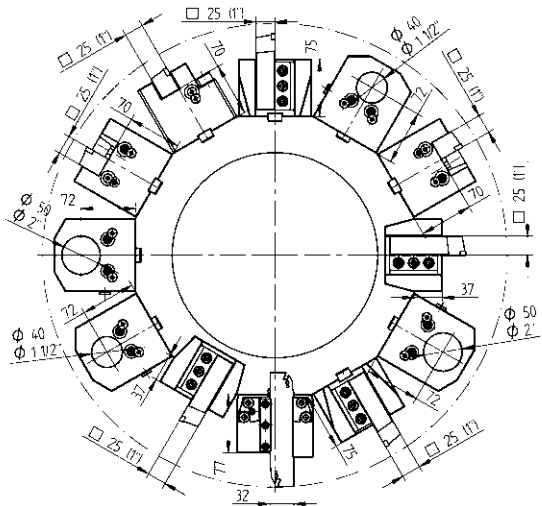

固定刀座 - 标准产品目录

固定刀座 - 标准产品目录



25 车端面 and 车削刀座

48-92428



25 车端面 and 车削刀座, HP-IC

48-92428-HP IC 80 bar



25 车端面 and 车削刀座, 短型

48-86991



25 车端面 and 车削刀座, 短型, HP-IC

48-86991-HP IC 80 bar



SH 32 切断刀用刀座, 可调节的

48-99060



SH 32 切断刀用刀座, 可调节的, 内部切削液供应, HP-IC

48-102256R IC 80 bar

SH 32 48-102256L IC 80 bar



25 车端面 and 镗削刀座

48-86719



25 车端面 and 镗削刀座, HP-IC

48-109249-HP IC 80 bar



组合刀座, LF=72

Ø 40 48-84375 IC 80 bar

Ø 50 48-107499 IC 80 bar



防护板

48-87089

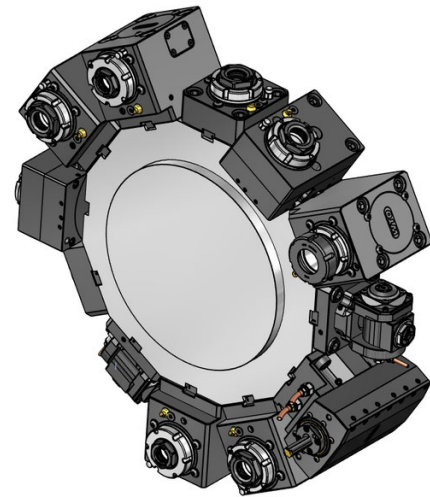
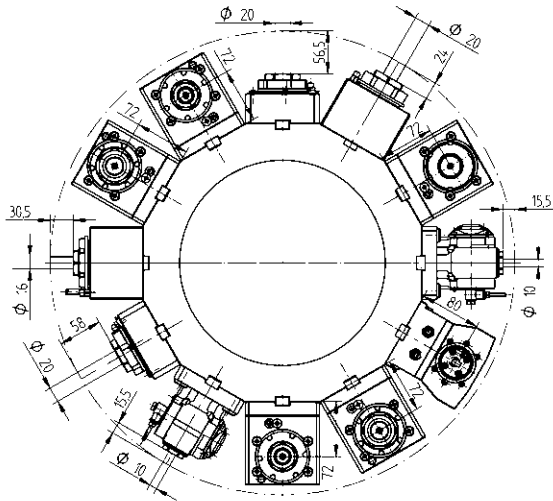

动力刀座 - QuickFlex®

动力刀座 - QuickFlex®



直结式钻/铣动力刀座

- ER-32 QF QF32-DNE-BT65A-058-E-A 1:1 EC
0067732000
- ER-32 QF QF32-DNE-BT65A-060-I-A 1:1 IC 100 bar
0067732000



直结式钻/铣动力刀座 (10000 RPM)

- ER-32 QF QF32-DNE-BT65A-058-E-HS-A 1:1 EC
0067732000
- ER-32 QF QF32-DNE-BT65A-060-I-HS-A 1:1 IC 100 bar
0067732000



直结式钻/铣动力刀座 - QF smart (EU, US, CA, JP)

- ER-32 QF QF32-DNE-BT65A-060-I-SB-A 1:1 IC 100 bar
0067732000
- LI-F12-01



直结式钻/铣动力刀座 (10000 RPM) - QF smart (EU, US, CA, JP)

- ER-32 QF QF32-DNE-BT65A-060-I-HS-SB-A 1:1 IC 100 bar
0067732000
- LI-F12-01



直角式钻/铣动力刀座, LF=72

- ER-32 QF 420532015-65 1:1 EC
0067732000
- ER-32 QF 420532016-65 1:1 IC 80 bar
0067732000



直角式钻/铣动力刀座, LF=72, (10000 RPM)

- ER-32 QF QF32-DNI-BT65A-072-E-HS-A 1:1 EC
0067732000
- ER-32 QF QF32-DNI-BT65A-072-I-HS-A 1:1 IC 100 bar
0067732000



直角式钻/铣动力刀座 - QF smart (EU, US, CA, JP), LF=72

- ER-32 QF QF32-DNI-BT65A-072-I-SB-A 1:1 IC 100 bar
0067732000
- LI-F12-01



直角式钻/铣动力刀座 (10000 RPM) - QF smart (EU, US, CA, JP), LF=72

- ER-32 QF QF32-DNI-BT65A-072-I-HS-SB-A 1:1 IC 100 bar
0067732000
- LI-F12-01

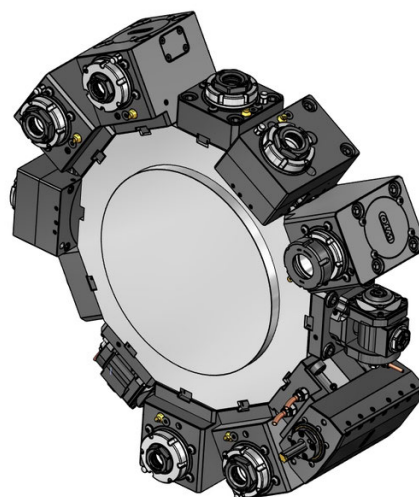
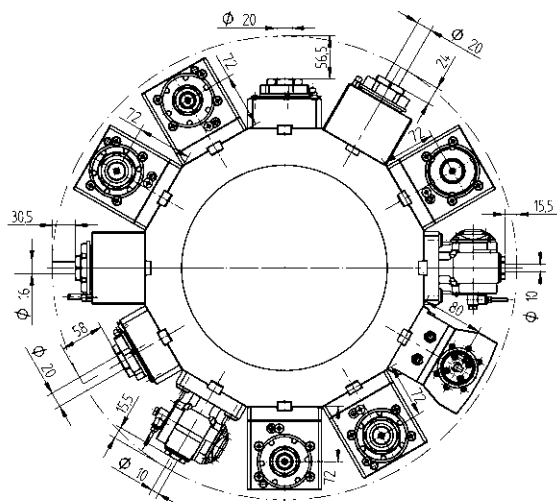

动力刀座 - 扩展产品目录



直结式钻/铣动力刀座

ER 40	ER40-DNE-BT65A-084-E-A	1:1	EC
	00675000079		
ER 40	ER40-DNE-BT65A-086-I-A	1:1	IC 100 bar
	00675000079		



直结偏位式钻/铣动力刀座

ER-32 QF	420132037-65	1:1	EC
	0067732000		
ER-32 QF	420132038-65	1:1	IC 80 bar
	0067732000		
ER-25 QF	420125010-65	1:2	EC
	0067725001		
ER-25 QF	420125011-65	1:2	IC 80 bar
	0067725001		



直角式钻/铣动力刀座, LF=72

ER 40	ER40-DNI-BT65A-072-E-A	1:1	EC
	00675000079		
ER 40	ER40-DNI-BT65A-072-I-A	1:1	IC 80 bar
	00675000079		

动力刀座 - 扩展产品目录



直角式钻/铣动力刀座, LF=72

ER-25 QF	QF25-DNI-BT65A-072-E-S-A	1:2	EC
	0067725001		
ER-25 QF	QF25-DNI-BT65A-072-I-S-A	1:2	IC 100 bar
	0067725001		
ER-32 QF	QF32-DNI-BT65A-072-E-T-A	2:1	EC
	0067732000		
ER-32 QF	QF32-DNI-BT65A-072-I-T-A	2:1	IC 100 bar
	0067732000		



可调角度钻/铣动力刀座

ER 16	411010002-65	1:1	EC
	00675000902		
ER 16	411010003-65	1:1	IC 80 bar
	00675000902		
ER 11	411007002-65	1:2	EC
	00675000914		
ER 11	411007003-65	1:2	IC 80 bar
	00675000914		



插槽刀座(内外径通用)

32 型式	414532001-65	1:1	EC
52 型式	414552001-65	1:1	EC

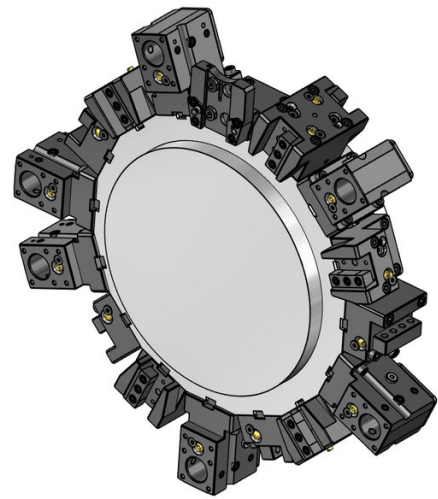
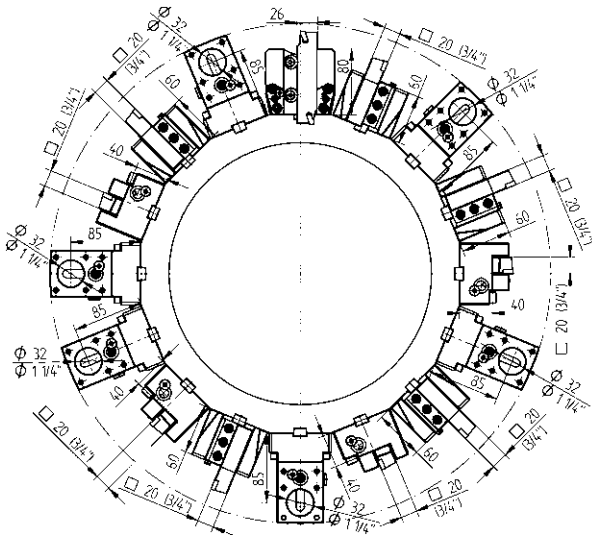

固定刀座 - 标准产品目录

固定刀座 - 标准产品目录

- 

20 车端面 and 车削刀座
48-95083
- 

20 车端面 and 车削刀座, HP-IC
48-100605-HP IC 80 bar
- 

25 车端面 and 车削刀座, HP-IC
48-104395-HP IC 80 bar
- 

20 车端面 and 车削刀座, 两侧的
48-95085
- 

20 车端面 and 车削刀座, 两侧的, HP-IC
48-95085-HP IC 80 bar
- 

20 车端面 and 镗削刀座
48-109148
- 

20 车端面 and 镗削刀座, HP-IC
48-109148-HP IC 80 bar

- 

25 车端面 and 镗削刀座, HP-IC
48-104397-HP IC 80 bar
- 

SH 26 切断刀用刀座, 可调节的
48-94968
- 

SH 26 切断刀用刀座, 可调节的, 内部切削液供应, HP-IC
48-102252R IC 80 bar
48-102252L IC 80 bar
- 

Ø 32 组合刀座, 通用的, LF=85
48-95998 IC 80 bar
 241132016 ER25
 241132020 ER32

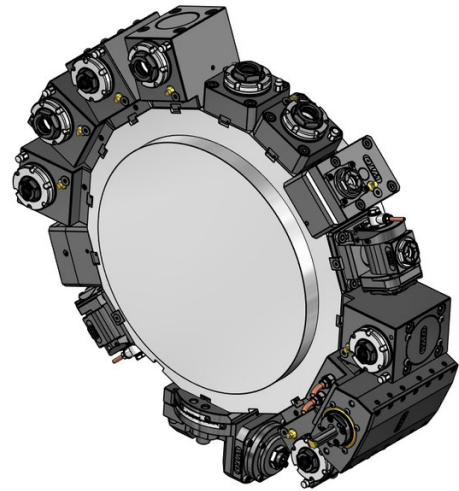
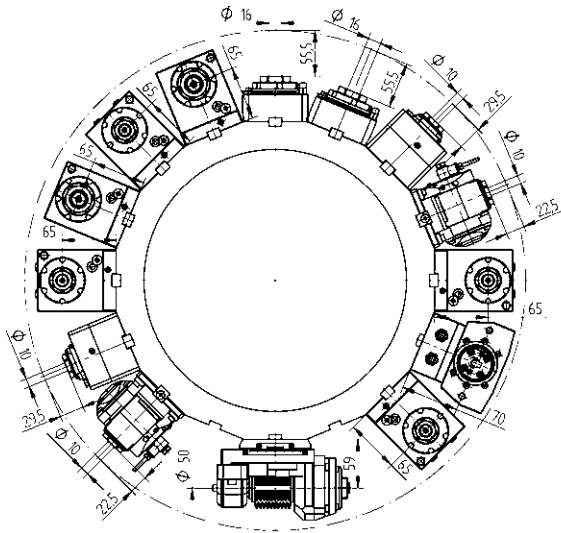

动力刀座 - QuickFlex®



直结式钻/铣动力刀座

ER-25 QF	420125015-45	1:1	EC
	0067725000		
ER-25 QF	420125016-45	1:1	IC 80 bar
	0067725000		



直角式钻/铣动力刀座, LF=65

ER-25 QF	420525015-45	1:1	EC
	0067725000		
ER-25 QF	420525016-45	1:1	IC 80 bar
	0067725000		

动力刀座 - 扩展产品目录



直结偏位式钻/铣动力刀座

ER 16	410410008-45	1:3	EC
	00675000937		
ER 16	410410002-45	1:3	IC 80 bar
	00675000937		



直角式钻/铣动力刀座, LF=65

ER-20 QF	420520018-45	1:2	EC
	0067720001		
ER-20 QF	420520019-45	1:2	IC 80 bar
	0067720001		
ER-25 QF	420525020-45	2:1	EC
	0067725000		
ER-25 QF	420525021-45	2:1	IC 80 bar
	0067725000		



可调角度钻/铣动力刀座

ER 16	411010008-45	1:1	EC
	00675000902		
ER 16	411010009-45	1:1	IC 80 bar
	00675000902		
ER 11	411007004-45	1:2	EC
	00675000914		
ER 11	411007005-45	1:2	IC 80 bar
	00675000914		

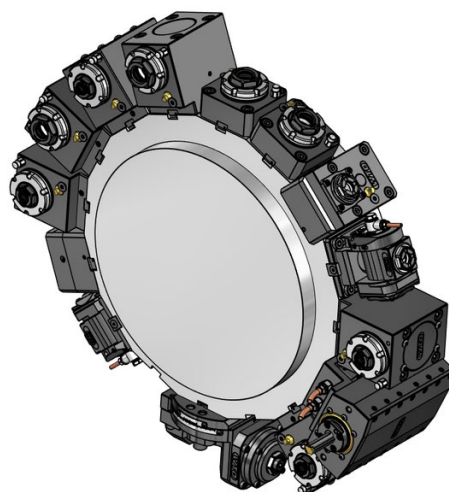
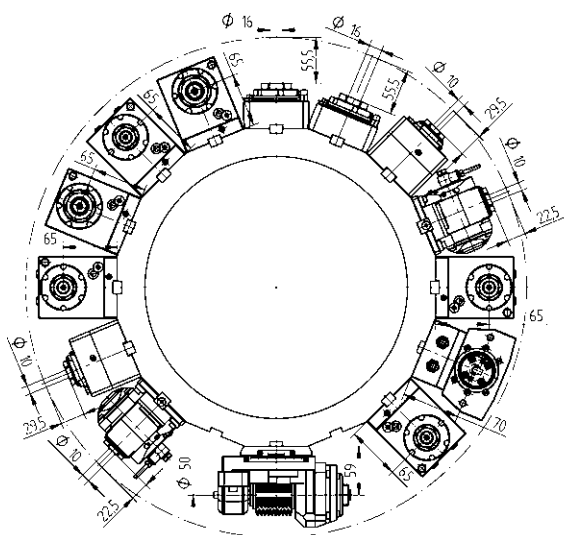

动力刀座 - 扩展产品目录



滚齿刀座

15-2 型式 410900003-45 1:1 EC

00675001015

160008152 Ø 8

160010152 Ø 10

160013152 Ø 13

160016152 Ø 16

160022152 Ø 22

160015152 Ø 5/8"

160019152 Ø 3/4"

110587



插槽刀座(内外径通用)

32 型式 414532005-45 1:1 EC

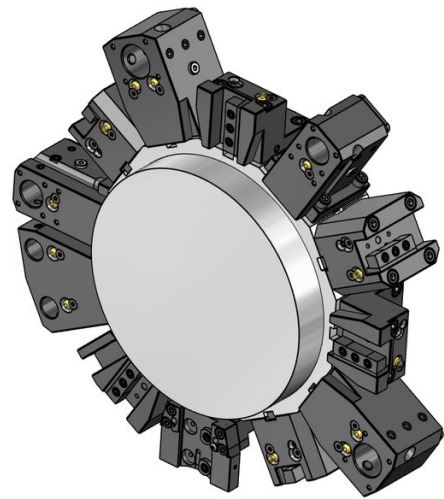
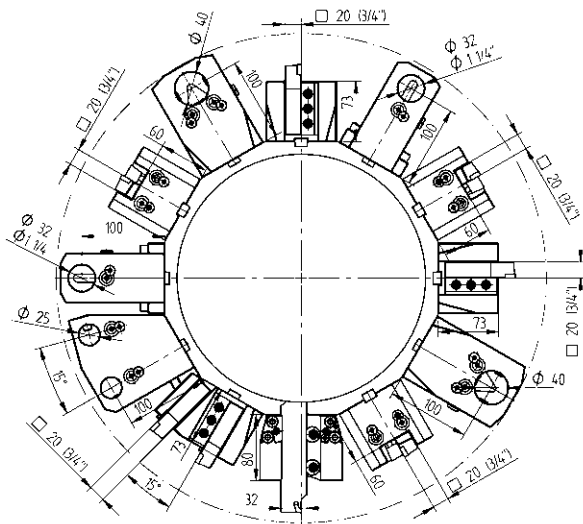

固定刀座 - 标准产品目录

固定刀座 - 标准产品目录



车端面 and 车削刀座

20 48-92036



车端面 and 车削刀座, HP-IC

20 48-92036-HP IC 80 bar



车端面 and 车削刀座, 两侧的

20 48-92038



车端面 and 车削刀座, 两侧的, HP-IC

20 48-92038-HP IC 80 bar



车端面 and 镗削刀座

20 48-92045



车端面 and 镗削刀座, HP-IC

20 48-92045-HP IC 80 bar



组合刀座, 通用的, LF=100

Ø 32 48-92043 IC 80 bar

 241132016 ER25

 241132020 ER32



组合刀座, 通用的, LF=100

Ø 40 48-103474 IC 80 bar

 241140020 ER32

 241140026 ER40

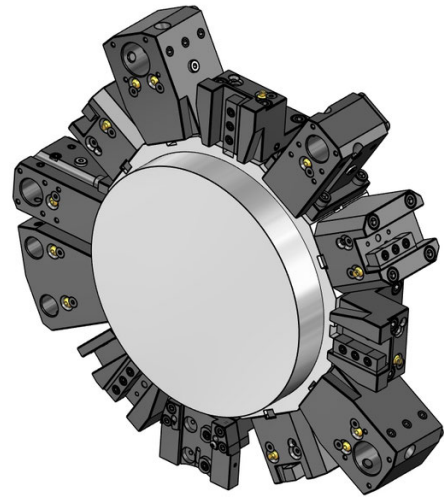
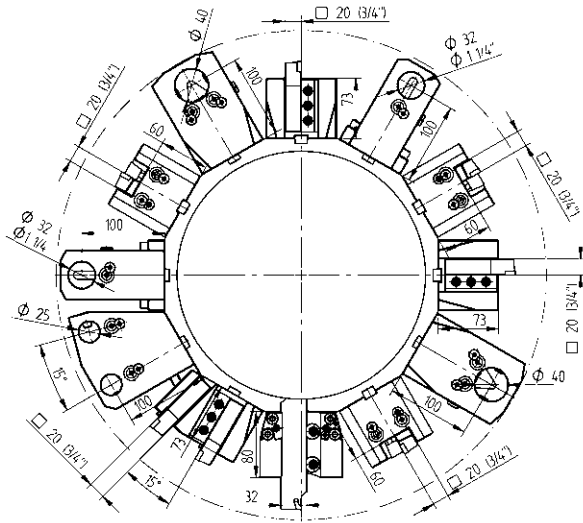

固定刀座 - 扩展产品目录



20

车端面 and 车削刀座, 2刀位, 24站位

48-87674



20

车端面 and 车削刀座, 两侧的, 2刀位, 24站位

48-92980



SH 32

切断刀用刀座, 可调节的

48-103287



SH 32

切断刀用刀座, 可调节的, 内部切削液供应, HP-IC

48-110160R

IC 80 bar

SH 32 48-110160L

IC 80 bar



SH 32

切断刀用刀座, 可调节的, 长型

48-103288



SH 32

切断刀用刀座, 可调节的, 长型, 内部切削液供应, HP-IC

48-111142R

IC 80 bar

343-810100R90

SH 32 48-111142L

IC 80 bar

343-810100L90



Ø 25

镗刀刀座, 2刀位, 24站位

48-87678

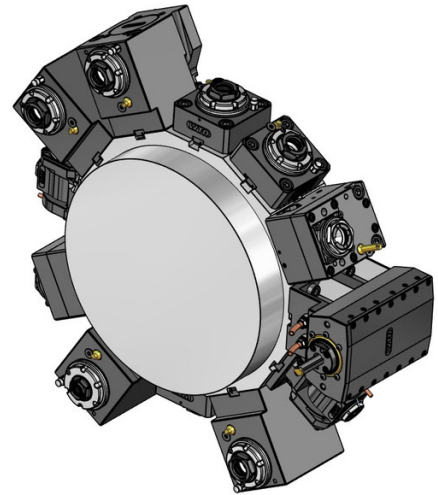
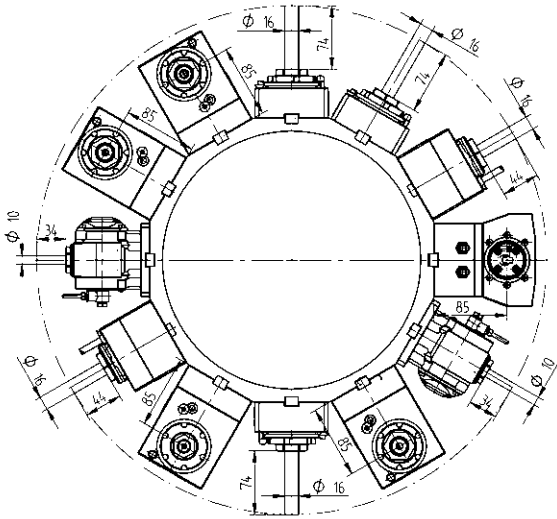

动力刀座 - QuickFlex®



直结式钻/铣动力刀座

ER-25 QF 420125015-55 1:1 EC
 0067725000

ER-25 QF 420125016-55 1:1 IC 80 bar
 0067725000



直角式钻/铣动力刀座, LF=85

ER-25 QF 420525018-55 1:1 EC
 0067725000

ER-25 QF 420525019-55 1:1 IC 80 bar
 0067725000



直角式钻/铣动力刀座, 两侧的, LF=85

ER-25 QF 420525020-55 1:1 EC
 0067725000

动力刀座 - 扩展产品目录



直结式钻/铣动力刀座

ER 32 410120010-55 1:1 EC
 0067725000

ER 32 410120011-55 1:1 IC 80 bar
 0067725000



直结式铣刀座 - 组合铣刀心轴, DIN6358

Ø 22 410222004-55 1:1 EC
 00675000483



直结偏位式钻/铣动力刀座

ER 25 410116029-55 1:1 EC
 00675000932

ER 25 410116030-55 1:1 IC 80 bar
 00675000932

ER 20 410113009-55 1:2 EC
 00675000939

ER 20 410113010-55 1:2 IC 80 bar
 00675000939

ER 16 410410004-55 1:3 EC
 00675000937

ER 16 410410005-55 1:3 IC 80 bar
 00675000937

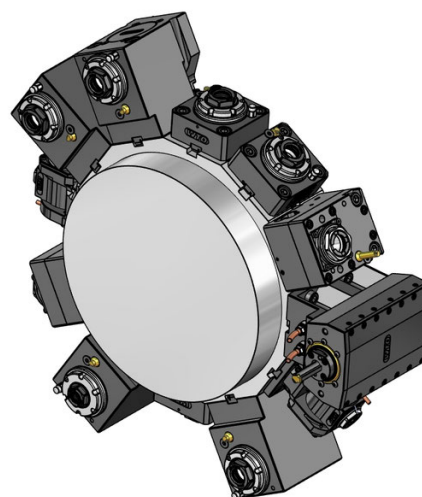
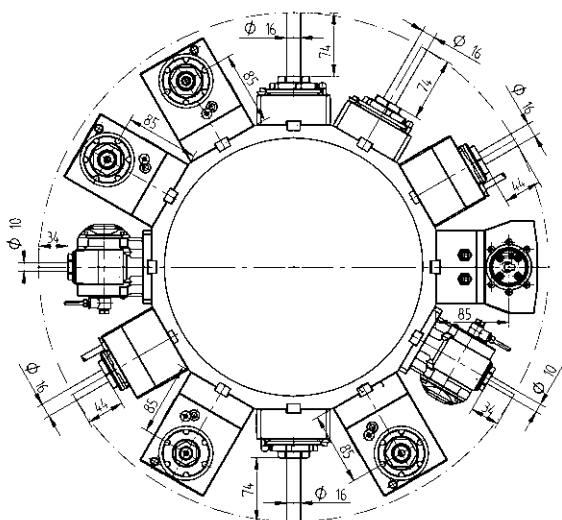

动力刀座 - 扩展产品目录



直角式钻/铣动力刀座, LF=85

ER 32	410520030-55 0067725000	1:1	EC
ER 32	410520031-55 0067725000	1:1	IC 80 bar
ER-20 QF	420520014-55 0067720001	1:2	EC
ER-20 QF	420520015-55 0067720001	1:2	IC 80 bar
ER 16	410810020-55 00675000841	1:3	EC
ER 16	410810021-55 00675000841	1:3	IC 80 bar
ER-25 QF	420525032-55 0067725000	2:1	EC
ER-25 QF	420525033-55 0067725000	2:1	IC 80 bar



直角式铣动力刀座 - 铣刀心轴, DIN6358, LF=85

Ø 22	410622011-55 00675000483	1:1	EC
------	-----------------------------	-----	----

动力刀座 - 扩展产品目录



可调角度钻/铣动力刀座

ER 16	411010005-55 00675000902	1:1	EC
ER 16	411010006-55 00675000902	1:1	IC 80 bar
ER 11	411007007-55 00675000914	1:2	EC
ER 11	411007008-55 00675000914	1:2	IC 80 bar



插槽刀座(内外径通用)

32 型式	414532000-55	1:1	EC
-------	--------------	-----	----

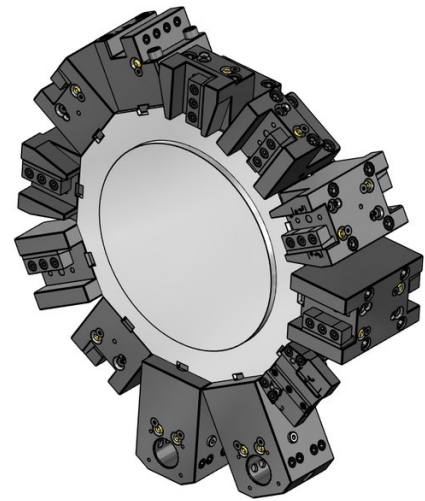
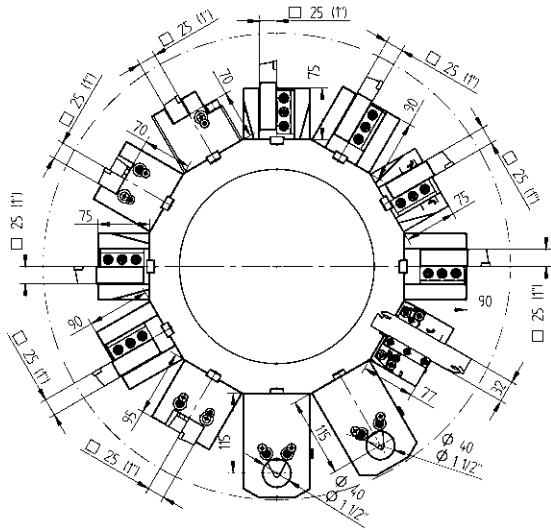

固定刀座 - 标准产品目录

固定刀座 - 标准产品目录



25

车端面 and 车削刀座
48-92428



25

车端面 and 车削刀座, HP-IC
48-92428-HP IC 80 bar



25

车端面 and 车削刀座, 长型
48-86711



25

车端面 and 车削刀座, 两侧的
48-92438



25

车端面 and 车削刀座, 两侧的, HP-IC
48-92438-HP IC 80 bar



25

车端面 and 车削刀座, 两侧的, 长型
48-84523



25

车端面 and 镗削刀座
48-86719



25

车端面 and 镗削刀座, HP-IC
48-109249-HP IC 80 bar



Ø 40

组合刀座, LF=115
48-86623 IC 80 bar

241140020 ER32

241140026 ER40



48-87089

防护板

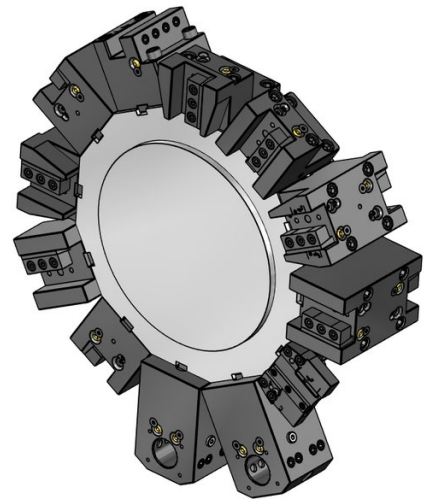
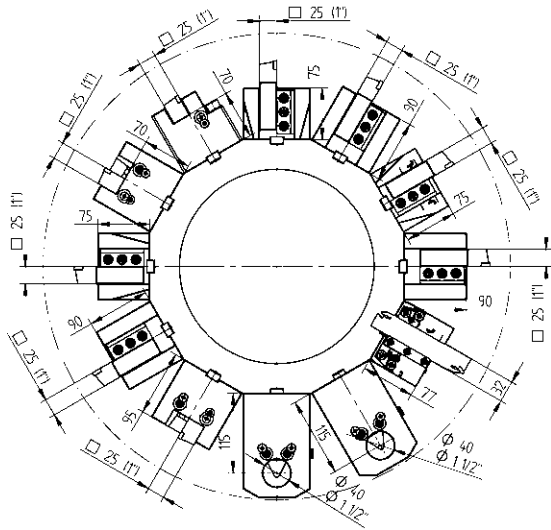

固定刀座 - 扩展产品目录



SH 32 切断刀用刀座, 可调节的
48-99060



SH 32 切断刀用刀座, 可调节的, 长型
48-100084



SH 32 切断刀用刀座, 可调节的, 内部切削液供应, HP-IC
SH 32 48-102256R IC 80 bar
SH 32 48-102256L IC 80 bar



SH 32 切断刀用刀座, 可调节的, 长型, 内部切削液供应, HP-IC
SH 32 48-100082R IC 80 bar
SH 32 48-100082L IC 80 bar

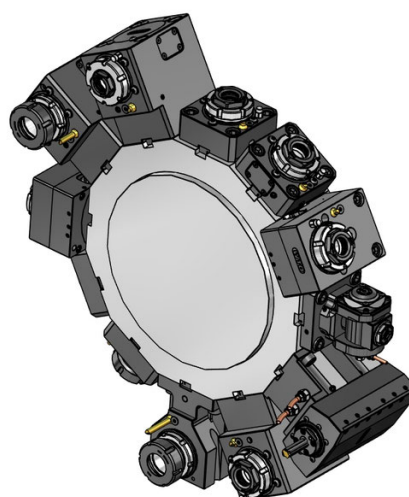
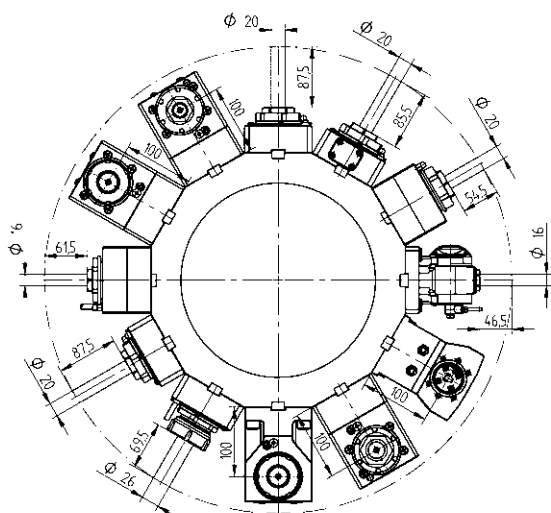

动力刀座 - QuickFlex®

动力刀座 - 扩展产品目录



直结式钻/铣动力刀座

- ER-32 QF QF32-DNE-BT65A-058-E-A 1:1 EC
0067732000
- ER-32 QF QF32-DNE-BT65A-060-I-A 1:1 IC 100 bar
0067732000



直结式钻/铣动力刀座 - QF smart (EU, US, CA, JP)

- ER-32 QF QF32-DNE-BT65A-060-I-SB-A 1:1 IC 100 bar
0067732000



直角式钻/铣动力刀座, LF=100

- ER-32 QF 420532018-65 1:1 EC
0067732000
- ER-32 QF QF32-DNI-BT65A-100-I-A 1:1 IC 100 bar
0067732000



直角式钻/铣动力刀座 - QF smart (EU, US, CA, JP), LF=100

- ER-32 QF QF32-DNI-BT65A-100-I-SB-A 1:1 IC 100 bar
0067732000



直角式钻/铣动力刀座, 两侧的, LF=100

- ER-32 QF 420532020-65 1:1 EC
0067732000



直结式钻/铣动力刀座

- ER 40 ER40-DNE-BT65A-084-E-A 1:1 EC
00675000079
- ER 40 ER40-DNE-BT65A-086-I-A 1:1 IC 100 bar
00675000079



直结偏位式钻/铣动力刀座

- ER-32 QF 420132037-65 1:1 EC
0067732000
- ER-32 QF 420132038-65 1:1 IC 80 bar
0067732000
- ER-25 QF 420125010-65 1:2 EC
0067725001
- ER-25 QF 420125011-65 1:2 IC 80 bar
0067725001



直角式钻/铣动力刀座, LF=100

- ER 40 410526007-65 1:1 EC
00675000079
- ER 40 410526008-65 1:1 IC 80 bar
00675000079

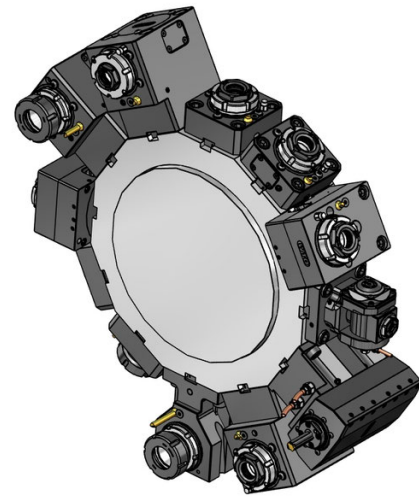
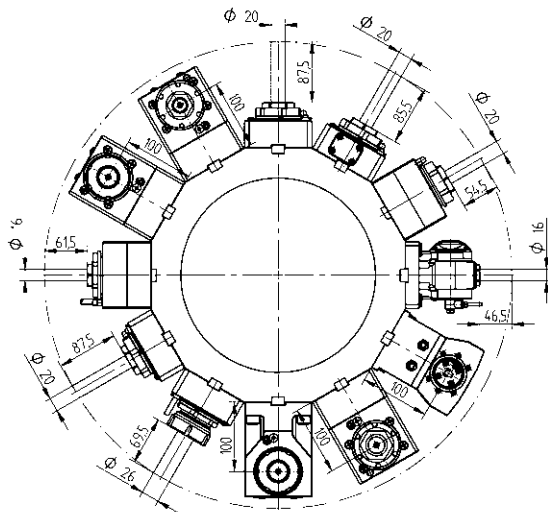

动力刀座 - 扩展产品目录

动力刀座 - 扩展产品目录



直角式钻/铣动力刀座, LF=100

ER-25 QF	QF25-DNI-BT65A-100-E-S-A 0067725001	1:2	EC
ER-25 QF	QF25-DNI-BT65A-100-I-S-A 0067725001	1:2	IC 100 bar
ER-32 QF	QF32-DNI-BT65A-100-E-T-A 0067732000	2:1	EC
ER-32 QF	QF32-DNI-BT65A-100-I-T-A 0067732000	2:1	IC 100 bar



插槽刀座(内外径通用)

32 型式	414532000-65	1:1	EC
-------	--------------	-----	----



直角后缩式钻/铣动力刀座

ER-32 QF	420532090-65 0067732000	1:1	EC
ER-32 QF	420532091-65 0067732000	1:1	IC 80 bar



可调角度钻/铣动力刀座

ER 16	411010002-65 00675000902	1:1	EC
ER 16	411010003-65 00675000902	1:1	IC 80 bar
ER 11	411007002-65 00675000914	1:2	EC
ER 11	411007003-65 00675000914	1:2	IC 80 bar

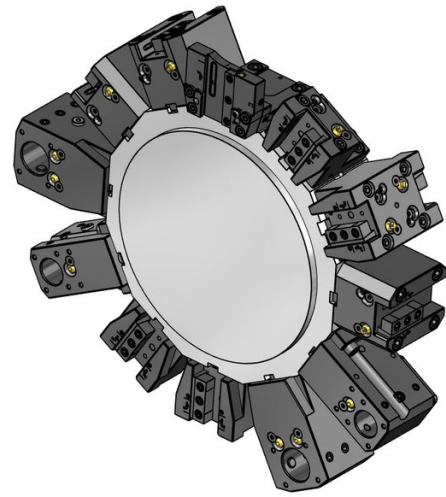
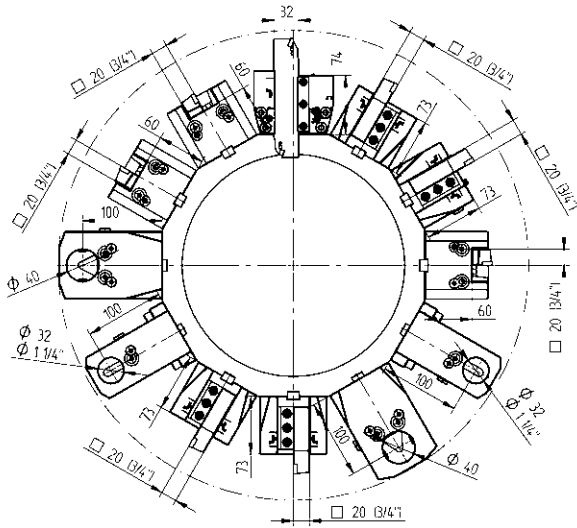

固定刀座 - 标准产品目录

固定刀座 - 标准产品目录



20

车端面 and 车削刀座
48-92036



20

车端面 and 车削刀座, HP-IC
48-92036-HP IC 80 bar



20

车端面 and 车削刀座, 两侧的
48-92038



20

车端面 and 车削刀座, 两侧的, HP-IC
48-92038-HP IC 80 bar



20

车端面 and 镗削刀座
48-92045



20

车端面 and 镗削刀座, HP-IC
48-92045-HP IC 80 bar



Ø 32

组合刀座, 通用的, LF=100
48-92043 IC 80 bar
241132016 ER25
241132020 ER32



Ø 40

组合刀座, 通用的, LF=100

48-103474

IC 80 bar

241140020 ER32

241140026 ER40

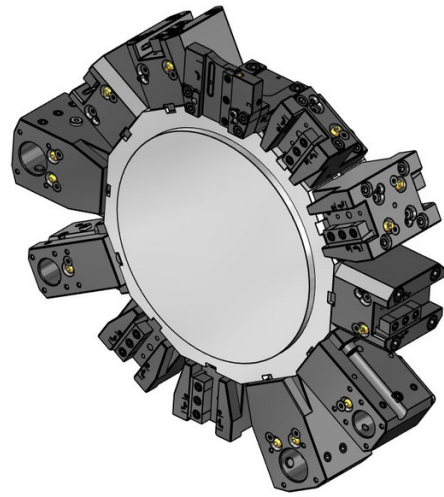
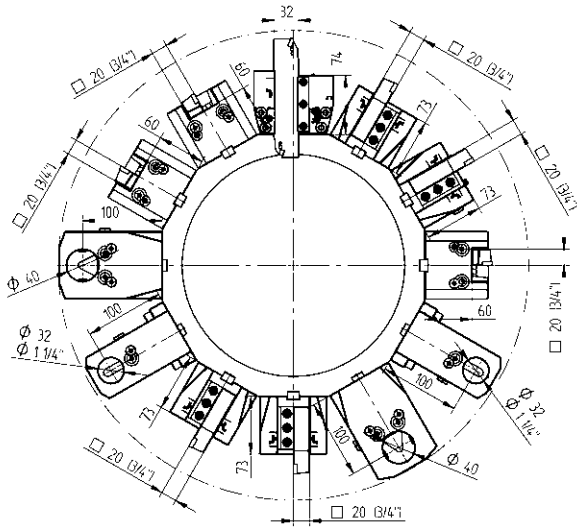

固定刀座 - 扩展产品目录



SH 32

切断刀用刀座, 可调节的

48-103287



SH 32

切断刀用刀座, 可调节的, 内部切削液供应, HP-IC

SH 32

48-110160R

IC 80 bar

48-110160L

IC 80 bar



SH 32

切断刀用刀座, 可调节的, 长型

48-103288



SH 32

切断刀用刀座, 可调节的, 长型, 内部切削液供应, HP-IC

SH 32

48-111142R

IC 80 bar

343-810100R90

SH 32

48-111142L

IC 80 bar

343-810100L90

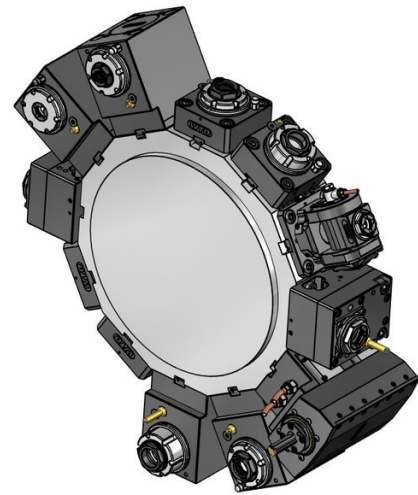
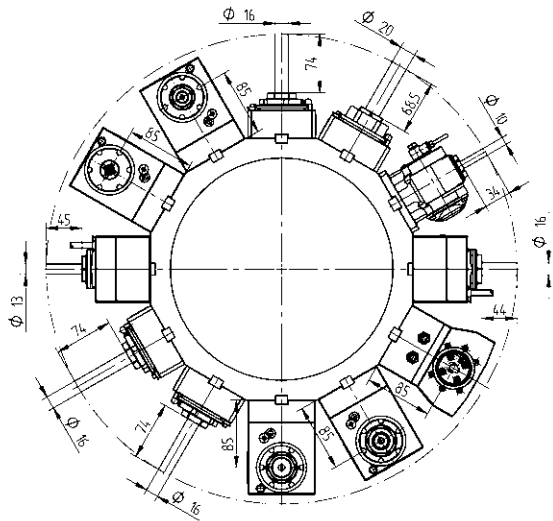

动力刀座 - QuickFlex®



直结式钻/铣动力刀座

ER-25 QF	420125015-55	1:1	EC
	0067725000		
ER-25 QF	420125016-55	1:1	IC 80 bar
	0067725000		



直角式钻/铣动力刀座, LF=85

ER-25 QF	420525018-55	1:1	EC
	0067725000		
ER-25 QF	420525019-55	1:1	IC 80 bar
	0067725000		



直角式钻/铣动力刀座, 两侧的, LF=85

ER-25 QF	420525020-55	1:1	EC
	0067725000		

动力刀座 - 扩展产品目录



直结式钻/铣动力刀座

ER 32	410120010-55	1:1	EC
	0067725000		
ER 32	410120011-55	1:1	IC 80 bar
	0067725000		

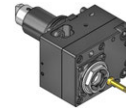

直结偏位式钻/铣动力刀座

ER 25	410116029-55	1:1	EC
	00675000932		
ER 25	410116030-55	1:1	IC 80 bar
	00675000932		
ER 20	410113009-55	1:2	EC
	00675000939		
ER 20	410113010-55	1:2	IC 80 bar
	00675000939		
ER 16	410410004-55	1:3	EC
	00675000937		
ER 16	410410005-55	1:3	IC 80 bar
	00675000937		

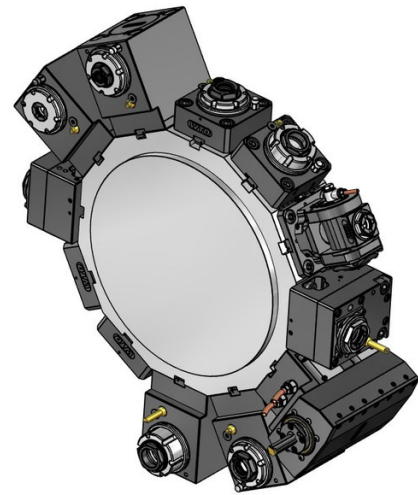
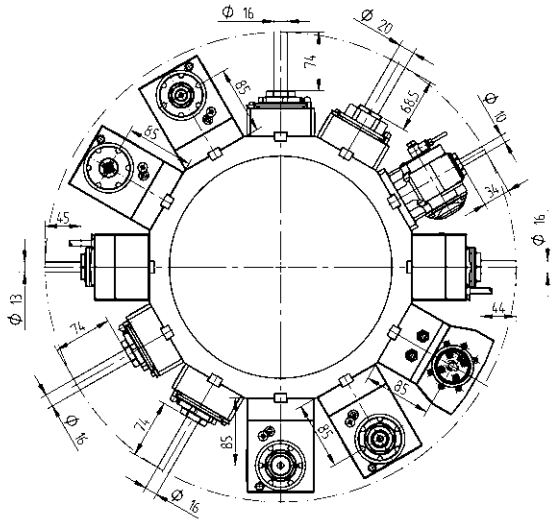

动力刀座 - 扩展产品目录



直角式钻/铣动力刀座, LF=85

ER 32	410520030-55 0067725000	1:1	EC
ER 32	410520031-55 0067725000	1:1	IC 80 bar
ER-20 QF	420520014-55 0067720001	1:2	EC
ER-20 QF	420520015-55 0067720001	1:2	IC 80 bar
ER 16	410810020-55 00675000841	1:3	EC
ER 16	410810021-55 00675000841	1:3	IC 80 bar
ER-25 QF	420525032-55 0067725000	2:1	EC
ER-25 QF	420525033-55 0067725000	2:1	IC 80 bar



直角式铣动力刀座 - 铣刀心轴, DIN6358, LF=85

Ø 22	410622011-55 00675000483	1:1	EC
------	-----------------------------	-----	----

动力刀座 - 扩展产品目录



可调角度钻/铣动力刀座

ER 16	411010005-55 00675000902	1:1	EC
ER 16	411010006-55 00675000902	1:1	IC 80 bar
ER 11	411007007-55 00675000914	1:2	EC
ER 11	411007008-55 00675000914	1:2	IC 80 bar

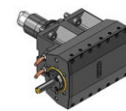

插槽刀座(内外径通用)

32 型式	414532000-55	1:1	EC
-------	--------------	-----	----

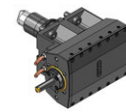

插槽刀座(内外径通用)

52 型式	414552002-55	1:1	EC
-------	--------------	-----	----

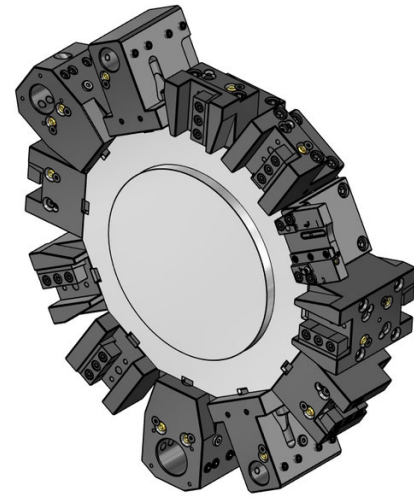
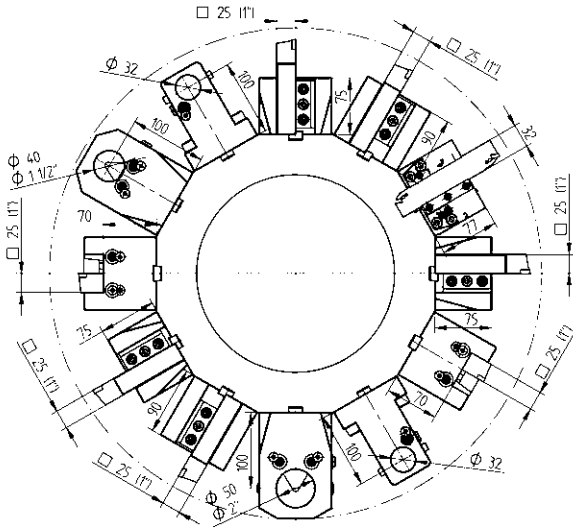

固定刀座 - 标准产品目录

固定刀座 - 标准产品目录



25

车端面 and 车削刀座
48-92428



25

车端面 and 车削刀座, HP-IC
48-92428-HP IC 80 bar



25

车端面 and 车削刀座, 长型
48-86711



25

车端面 and 车削刀座, 两侧的
48-92438



25

车端面 and 车削刀座, 两侧的, HP-IC
48-92438-HP IC 80 bar



25

车端面 and 车削刀座, 两侧的, 长型
48-84523



25

车端面 and 镗削刀座
48-86719



25

车端面 and 镗削刀座, HP-IC
48-109249-HP IC 80 bar



Ø 40

组合刀座, LF=100
48-92397 IC 80 bar

241140020 ER32

241140026 ER40

Ø 50

48-92467 IC 80 bar



Ø 32

镗刀刀座, 两侧的
48-101033



48-87089

防护板

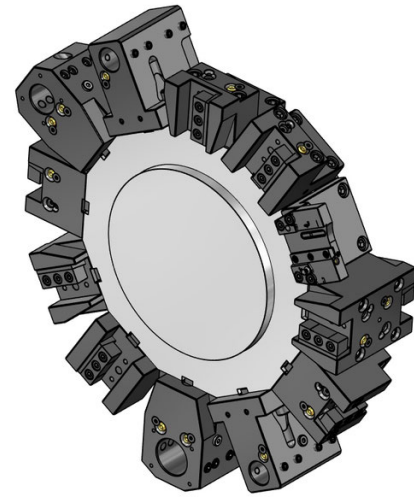
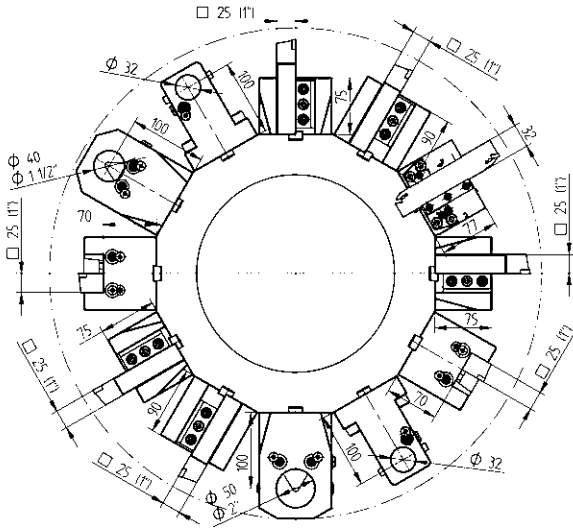

固定刀座 - 扩展产品目录



SH 32

切断刀用刀座, 可调节的

48-99060



SH 32

切断刀用刀座, 可调节的, 长型

48-100084



SH 32

切断刀用刀座, 可调节的, 内部切削液供应, HP-IC

48-102256R

IC 80 bar

SH 32

48-102256L

IC 80 bar



SH 32

切断刀用刀座, 可调节的, 长型, 内部切削液供应, HP-IC

48-100082R

IC 80 bar

SH 32

48-100082L

IC 80 bar



Ø 50

镗刀刀座, 带槽, LF=100

48-119005

EC

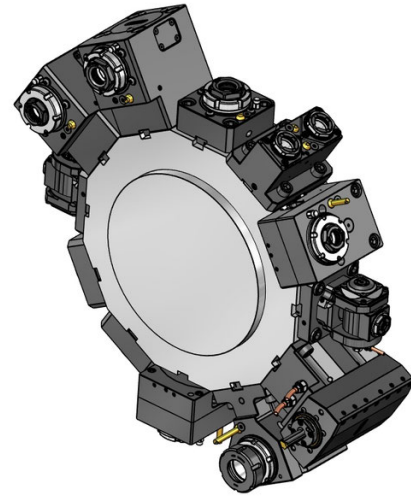
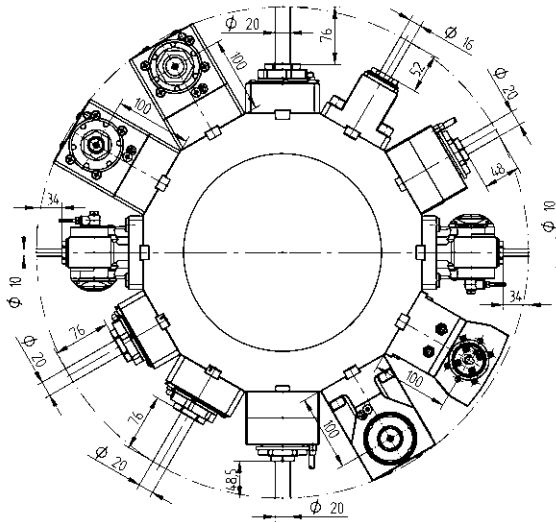

动力刀座 - QuickFlex®

动力刀座 - 扩展产品目录



直结式钻/铣动力刀座

- | | | | |
|----------|------------------------|-----|------------|
| ER-32 QF | QF32-DNE-BT65A-058-E-A | 1:1 | EC |
| | 0067732000 | | |
| ER-32 QF | QF32-DNE-BT65A-060-I-A | 1:1 | IC 100 bar |
| | 0067732000 | | |



直结式钻/铣动力刀座

- | | | | |
|-------|------------------------|-----|------------|
| ER 40 | ER40-DNE-BT65A-084-E-A | 1:1 | EC |
| | 00675000079 | | |
| ER 40 | ER40-DNE-BT65A-086-I-A | 1:1 | IC 100 bar |
| | 00675000079 | | |



直结式钻/铣动力刀座 - QF smart (EU, US, CA, JP)

- | | | | |
|----------|---------------------------|-----|------------|
| ER-32 QF | QF32-DNE-BT65A-060-I-SB-A | 1:1 | IC 100 bar |
| | 0067732000 | | |



直结偏位式钻/铣动力刀座

- | | | | |
|----------|--------------|-----|-----------|
| ER-32 QF | 420132037-65 | 1:1 | EC |
| | 0067732000 | | |
| ER-32 QF | 420132038-65 | 1:1 | IC 80 bar |
| | 0067732000 | | |
| ER-25 QF | 420125010-65 | 1:2 | EC |
| | 0067725001 | | |
| ER-25 QF | 420125011-65 | 1:2 | IC 80 bar |
| | 0067725001 | | |



直角式钻/铣动力刀座, LF=100

- | | | | |
|----------|------------------------|-----|------------|
| ER-32 QF | 420532018-65 | 1:1 | EC |
| | 0067732000 | | |
| ER-32 QF | QF32-DNI-BT65A-100-I-A | 1:1 | IC 100 bar |
| | 0067732000 | | |



直角式钻/铣动力刀座, LF=100

- | | | | |
|-------|--------------|-----|-----------|
| ER 40 | 410526007-65 | 1:1 | EC |
| | 00675000079 | | |
| ER 40 | 410526008-65 | 1:1 | IC 80 bar |
| | 00675000079 | | |



直角式钻/铣动力刀座 - QF smart (EU, US, CA, JP), LF=100

- | | | | |
|----------|---------------------------|-----|------------|
| ER-32 QF | QF32-DNI-BT65A-100-I-SB-A | 1:1 | IC 100 bar |
| | 0067732000 | | |

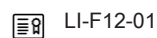

直角式钻/铣动力刀座, 两侧的, LF=100

- | | | | |
|----------|--------------|-----|----|
| ER-32 QF | 420532020-65 | 1:1 | EC |
| | 0067732000 | | |

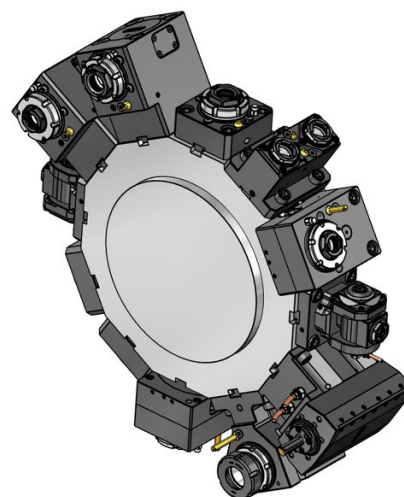
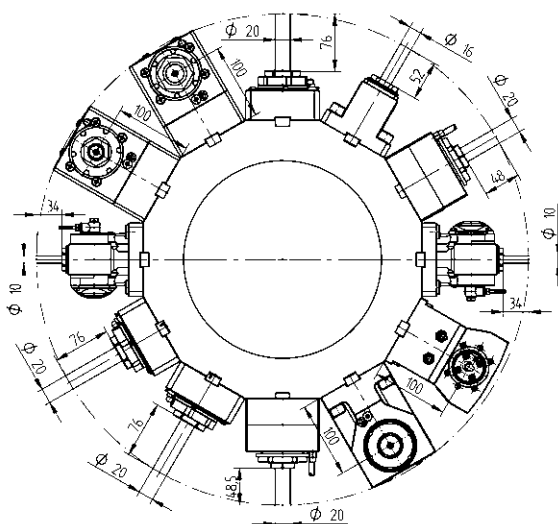

动力刀座 - 扩展产品目录

动力刀座 - 扩展产品目录



直角式钻/铣动力刀座, LF=100

ER-25 QF	QF25-DNI-BT65A-100-E-S-A	1:2	EC
	0067725001		
ER-25 QF	QF25-DNI-BT65A-100-I-S-A	1:2	IC 100 bar
	0067725001		
ER-32 QF	QF32-DNI-BT65A-100-E-T-A	2:1	EC
	0067732000		
ER-32 QF	QF32-DNI-BT65A-100-I-T-A	2:1	IC 100 bar
	0067732000		



直角后缩式钻/铣动力刀座

ER-32 QF	420532090-65	1:1	EC
	0067732000		
ER-32 QF	420532091-65	1:1	IC 80 bar
	0067732000		



可调角度钻/铣动力刀座

ER 16	411010002-65	1:1	EC
	00675000902		
ER 16	411010003-65	1:1	IC 80 bar
	00675000902		
ER 11	411007002-65	1:2	EC
	00675000914		
ER 11	411007003-65	1:2	IC 80 bar
	00675000914		



直结式钻/铣刀座, 两侧的

ER 25	413002005-65	1:1	EC
	00675000907		



插槽刀座(内外径通用)

32 型式	414532000-65	1:1	EC
-------	--------------	-----	----



插槽刀座(内外径通用)

52 型式	414552000-65	1:1	EC
-------	--------------	-----	----

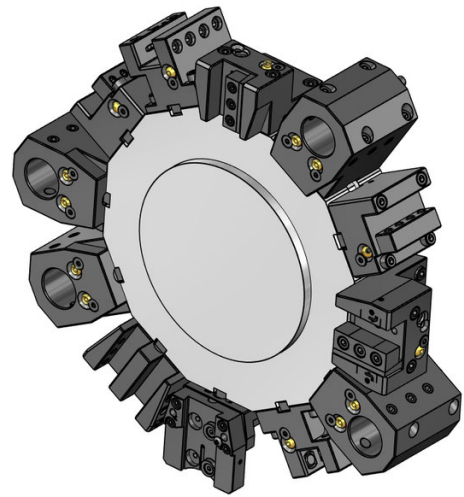
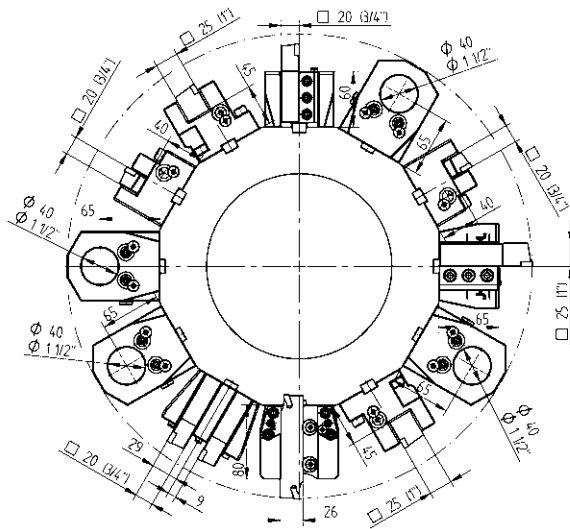

固定刀座 - 标准产品目录

固定刀座 - 标准产品目录

- 

20 车端面 and 车削刀座
48-95083
- 

20 车端面 and 车削刀座, HP-IC
48-100605-HP IC 80 bar
- 

25 车端面 and 车削刀座, HP-IC
48-104395-HP IC 80 bar
- 

20 车端面 and 车削刀座, 两侧的
48-95085
- 

20 车端面 and 车削刀座, 两侧的, HP-IC
48-95085-HP IC 80 bar
- 

20 (3/4") 车端面 and 车削刀座, 两侧的, 2刀位, Y-轴
48-110811
- 

20 车端面 and 镗削刀座
48-109148

- 

20 车端面 and 镗削刀座, HP-IC
48-109148-HP IC 80 bar
- 

25 车端面 and 镗削刀座, HP-IC
48-104397-HP IC 80 bar
- 

SH 26 切断刀用刀座, 可调节的
48-94968
- 

SH 26 切断刀用刀座, 可调节的, 内部切削液供应, HP-IC
48-102252R IC 80 bar
- 

SH 26 切断刀用刀座, 可调节的, 内部切削液供应, HP-IC
48-102252L IC 80 bar
- 

Ø 40 组合刀座, LF=65
48-95090 IC 80 bar

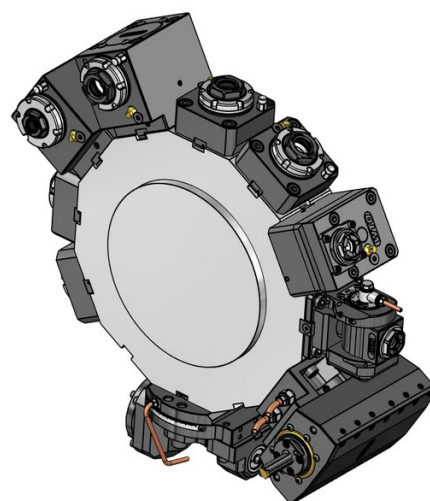
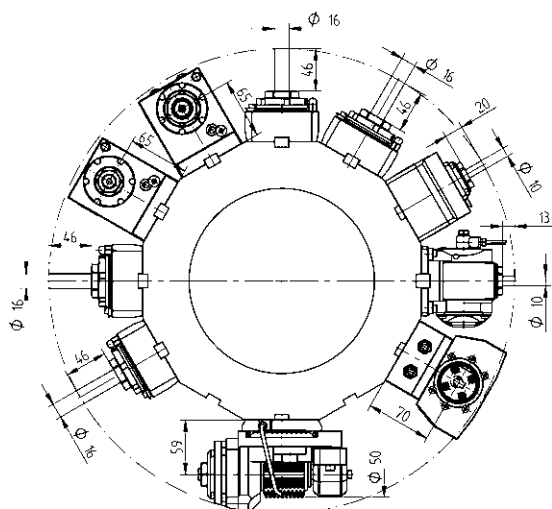

动力刀座 - QuickFlex®



直结式钻/铣动力刀座

- ER-25 QF 420125015-45 1:1 EC
0067725000
- ER-25 QF 420125016-45 1:1 IC 80 bar
0067725000



直结式钻/铣动力刀座 (12000 RPM)

- ER-25 QF 430125019-45 1:1 EC
0067725000
- ER-25 QF 430125020-45 1:1 IC 100 bar
0067725000



直角式钻/铣动力刀座, LF=65

- ER-25 QF 420525015-45 1:1 EC
0067725000
- ER-25 QF 420525016-45 1:1 IC 80 bar
0067725000

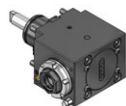

直角式钻/铣动力刀座 (12000 RPM)

- ER-25 QF 420525054-45 1:1 EC
0067725000
- ER-25 QF 420525055-45 1:1 IC 80 bar
0067725000

动力刀座 - 扩展产品目录



直结偏位式钻/铣动力刀座

- ER 16 410410008-45 1:3 EC
00675000937
- ER 16 410410002-45 1:3 IC 80 bar
00675000937



直角式钻/铣动力刀座, LF=65

- ER-20 QF 420520018-45 1:2 EC
0067720001
- ER-20 QF 420520019-45 1:2 IC 80 bar
0067720001
- ER-25 QF 420525020-45 2:1 EC
0067725000
- ER-25 QF 420525021-45 2:1 IC 80 bar
0067725000



可调角度钻/铣动力刀座

- ER 16 411010008-45 1:1 EC
00675000902
- ER 16 411010009-45 1:1 IC 80 bar
00675000902
- ER 11 411007004-45 1:2 EC
00675000914
- ER 11 411007005-45 1:2 IC 80 bar
00675000914

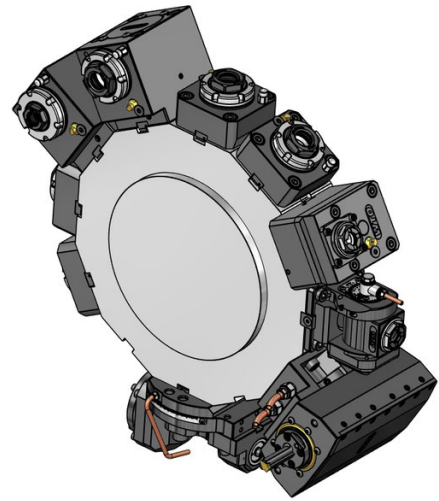
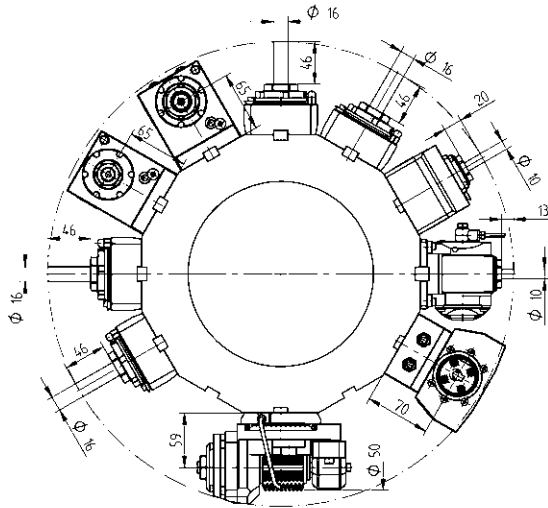

动力刀座 - 扩展产品目录

动力刀座 - 扩展产品目录



滚齿刀座

- | | | | |
|---------|------------------|-----|----|
| 15-2 型式 | 410900003-45 | 1:1 | EC |
| | 00675001015 | | |
| | 160008152 Ø 8 | | |
| | 160010152 Ø 10 | | |
| | 160013152 Ø 13 | | |
| | 160016152 Ø 16 | | |
| | 160022152 Ø 22 | | |
| | 160015152 Ø 5/8" | | |
| | 160019152 Ø 3/4" | | |
| | 110587 | | |



插槽刀座(内外径通用)

- | | | | |
|-------|--------------|-----|----|
| 32 型式 | 414532005-45 | 1:1 | EC |
|-------|--------------|-----|----|



直结式钻/铣刀座, 2刀位, Y-轴

- | | | | |
|-------|--------------|-----|-----------|
| ER 20 | 413002006-45 | 1:1 | EC |
| | 00675000947 | | |
| ER 20 | 413002008-45 | 1:1 | IC 80 bar |
| | 00675000947 | | |



二轴直角式钻/铣动力刀座, Y-轴

- | | | | |
|-------|--------------|-----|-----------|
| ER 20 | 413502001-45 | 1:1 | EC |
| | 00675000939 | | |
| ER 20 | 413502002-45 | 1:1 | IC 80 bar |
| | 00675000939 | | |

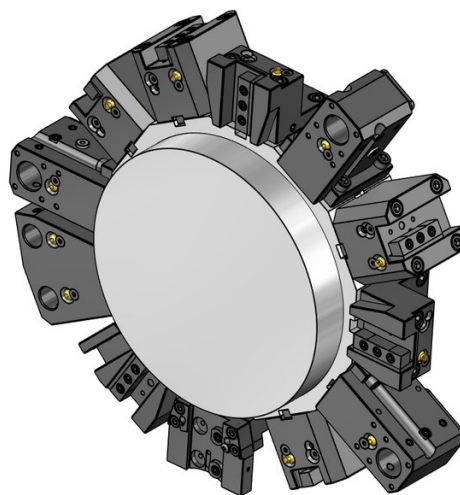
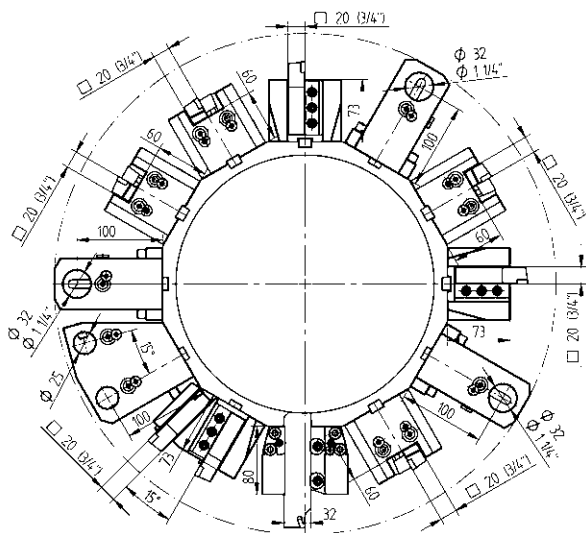

固定刀座 - 标准产品目录

固定刀座 - 扩展产品目录

- 

车端面 and 车削刀座
20 48-92036
- 

车端面 and 车削刀座, HP-IC
20 48-92036-HP IC 80 bar
- 

车端面 and 车削刀座, 两侧的
20 48-92038
- 

车端面 and 车削刀座, 两侧的, HP-IC
20 48-92038-HP IC 80 bar
- 

车端面 and 镗削刀座
20 48-92045
- 

车端面 and 镗削刀座, HP-IC
20 48-92045-HP IC 80 bar
- 

组合刀座, 通用的, LF=100
Ø 32 48-92043 IC 80 bar

 -  241132016 ER25
 -  241132020 ER32

- 

车端面 and 车削刀座, 2刀位, 24站位
20 48-87674
- 

车端面 and 车削刀座, 两侧的, 2刀位, 24站位
20 48-92980
- 

切断刀用刀座, 可调节的
SH 32 48-103287
- 

切断刀用刀座, 可调节的, 内部切削液供应, HP-IC
SH 32 48-110160R IC 80 bar
SH 32 48-110160L IC 80 bar
- 

切断刀用刀座, 可调节的, 长型
SH 32 48-103288
- 

切断刀用刀座, 可调节的, 长型, 内部切削液供应, HP-IC
SH 32 48-111142R IC 80 bar
343-810100R90
SH 32 48-111142L IC 80 bar
343-810100L90
- 

镗刀刀座, 2刀位, 24站位
Ø 25 48-87678

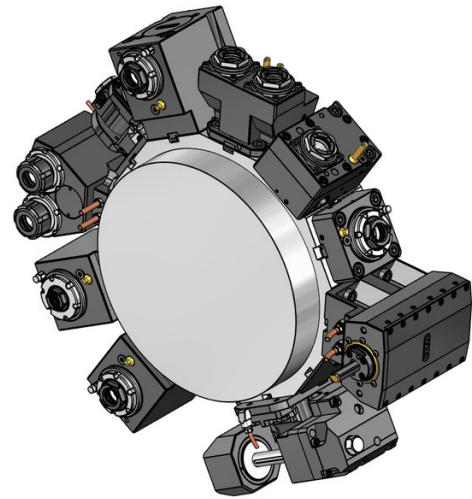
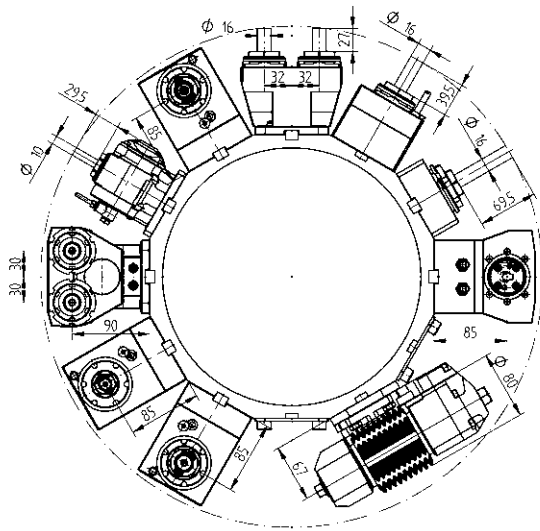

动力刀座 - QuickFlex®



直结式钻/铣动力刀座

ER-25 QF 420125015-55 1:1 EC
 0067725000

ER-25 QF 420125016-55 1:1 IC 80 bar
 0067725000



直角式钻/铣动力刀座, LF=85

ER-25 QF 420525018-55 1:1 EC
 0067725000

ER-25 QF 420525019-55 1:1 IC 80 bar
 0067725000



直角式钻/铣动力刀座, 两侧的, LF=85

ER-25 QF 420525020-55 1:1 EC
 0067725000

动力刀座 - 扩展产品目录



直结式钻/铣动力刀座

ER 32 410120010-55 1:1 EC
 0067725000

ER 32 410120011-55 1:1 IC 80 bar
 0067725000



直结式铣刀座 - 组合铣刀心轴, DIN6358

Ø 22 410222004-55 1:1 EC
 00675000483



直结偏位式钻/铣动力刀座

ER 25 410116029-55 1:1 EC
 00675000932

ER 25 410116030-55 1:1 IC 80 bar
 00675000932

ER 20 410113009-55 1:2 EC
 00675000939

ER 20 410113010-55 1:2 IC 80 bar
 00675000939

ER 16 410410004-55 1:3 EC
 00675000937

ER 16 410410005-55 1:3 IC 80 bar
 00675000937

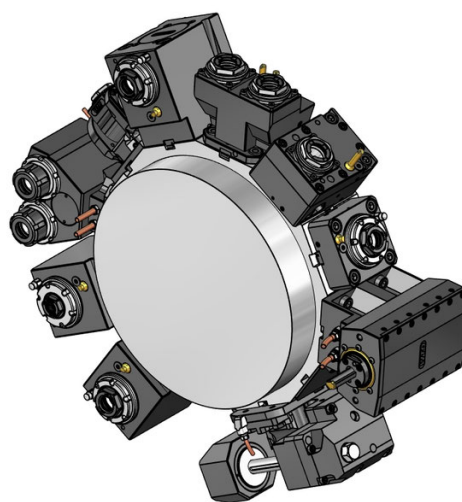
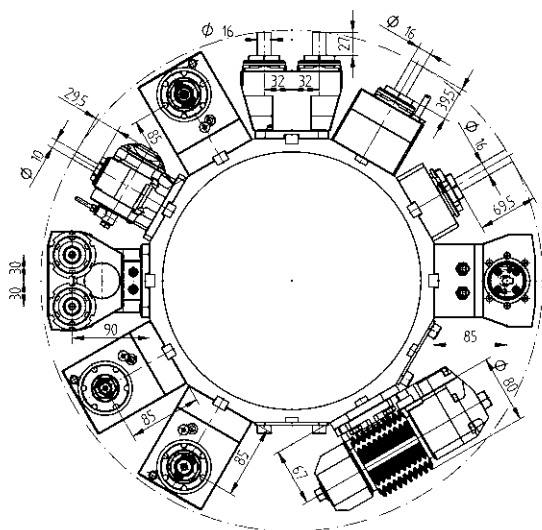

动力刀座 - 扩展产品目录



直角式钻/铣动力刀座, LF=85

ER 32	410520030-55	1:1	EC
	0067725000		
ER 32	410520031-55	1:1	IC 80 bar
	0067725000		
ER-20 QF	420520014-55	1:2	EC
	0067720001		
ER-20 QF	420520015-55	1:2	IC 80 bar
	0067720001		
ER 16	410810020-55	1:3	EC
	00675000841		
ER 16	410810021-55	1:3	IC 80 bar
	00675000841		
ER-25 QF	420525032-55	2:1	EC
	0067725000		
ER-25 QF	420525033-55	2:1	IC 80 bar
	0067725000		



直角式铣动力刀座 - 铣刀心轴, DIN6358, LF=85

Ø 22	410622011-55	1:1	EC
	00675000483		

动力刀座 - 扩展产品目录



可调角度钻/铣动力刀座

ER 16	411010005-55	1:1	EC
	00675000902		
ER 16	411010006-55	1:1	IC 80 bar
	00675000902		
ER 11	411007007-55	1:2	EC
	00675000914		
ER 11	411007008-55	1:2	IC 80 bar
	00675000914		



滚齿刀座

16-1 型式	411500002-55	1:1	EC
16-1 型式	411500001-55	2:1	EC
	00675000927		
	160016161 Ø 16		
	160022161 Ø 22		
	160027161 Ø 27		
	160015161 Ø 5/8"		
	160019161 Ø 3/4"		
	160025161 Ø 1"		
	160031161 Ø 1 1/4"		
	110587		

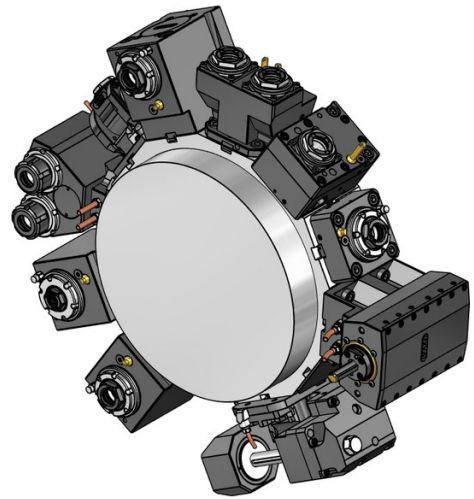
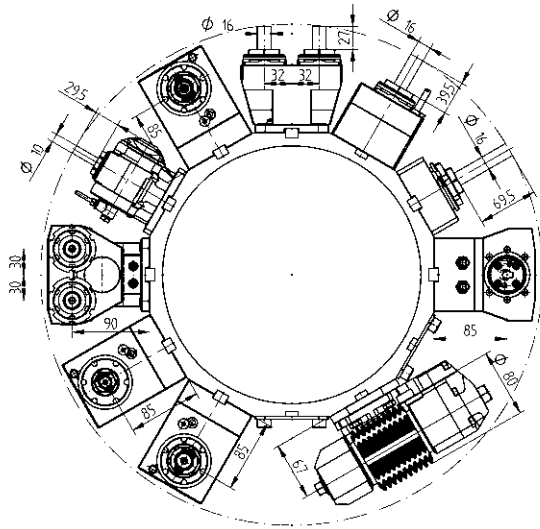

动力刀座 - 扩展产品目录



直结式钻/铣刀座, 2刀位, Y-轴

ER 25 413002004-55 1:1 EC
 00675000970

ER 25 413002003-55 1:1 IC 80 bar
 00675000970



二轴直角式钻/铣动力刀座, Y-轴

ER 25 413502007-55 1:1 EC
 00675000915

ER 25 413502008-55 1:1 IC 80 bar
 00675000915

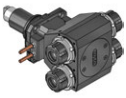

二轴直角式钻/铣动力刀座, 两侧的, Y-轴

ER 25 413502006-55 1:1 EC
 00675000915

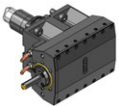

插槽刀座(内外径通用)

32 型式 414532000-55 1:1 EC

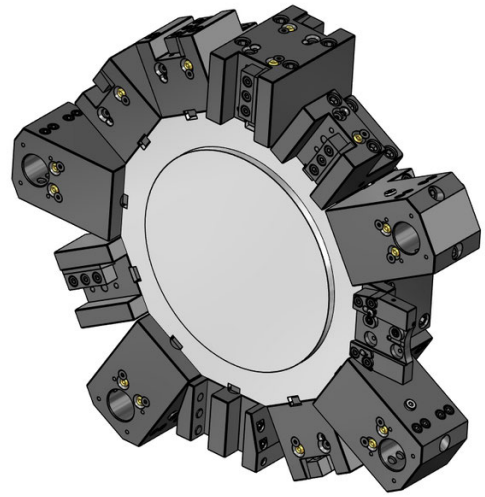
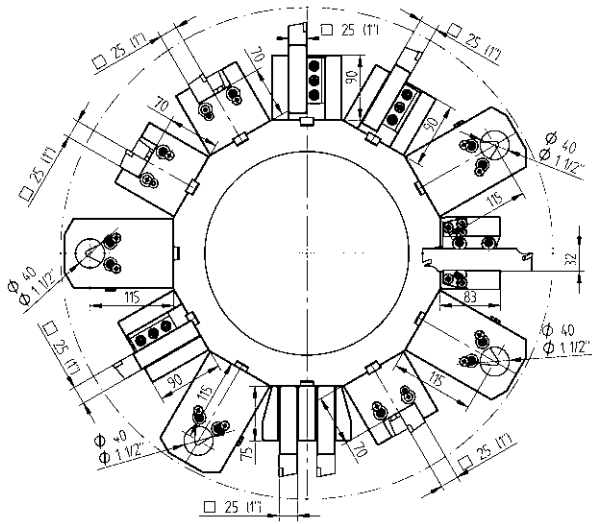

固定刀座 - 标准产品目录

固定刀座 - 标准产品目录



25

车端面 and 车削刀座
48-92428



25

车端面 and 车削刀座, HP-IC
48-92428-HP IC 80 bar



25

车端面 and 车削刀座, 长型
48-86711



25

车端面 and 车削刀座, 两侧的
48-92438



25

车端面 and 车削刀座, 两侧的, HP-IC
48-92438-HP IC 80 bar



25

车端面 and 车削刀座, 两侧的, 长型
48-84523



25

车端面 and 镗削刀座
48-86719



25

车端面 and 镗削刀座, HP-IC
48-109249-HP IC 80 bar



Ø 40

组合刀座, LF=115
48-86623 IC 80 bar

241140020 ER32

241140026 ER40



48-87089

防护板

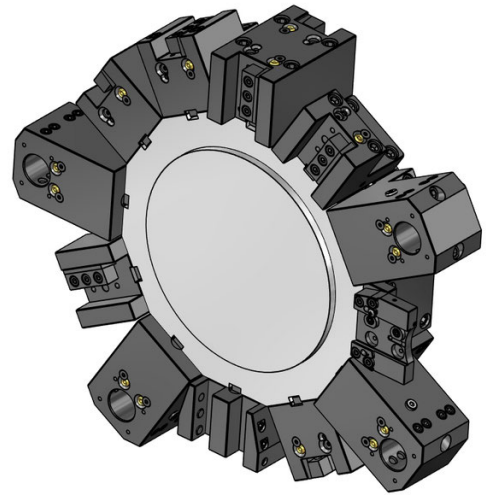
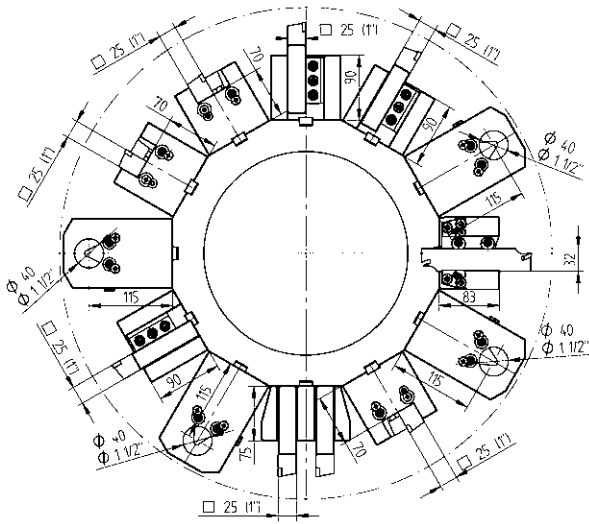

固定刀座 - 扩展产品目录



25(1")

车端面 and 车削刀座, 2刀位, Y-轴

48-86103



25(1")

车端面 and 车削刀座, 两侧的, 2刀位, Y-轴

48-86150



SH 32

切断刀用刀座, 可调节的

48-99060



SH 32

切断刀用刀座, 可调节的, 长型

48-100084



SH 32

切断刀用刀座, 可调节的, 内部切削液供应, HP-IC

48-102256R

IC 80 bar

SH 32

48-102256L

IC 80 bar



SH 32

切断刀用刀座, 可调节的, 长型, 内部切削液供应, HP-IC

48-100082R

IC 80 bar

SH 32

48-100082L

IC 80 bar

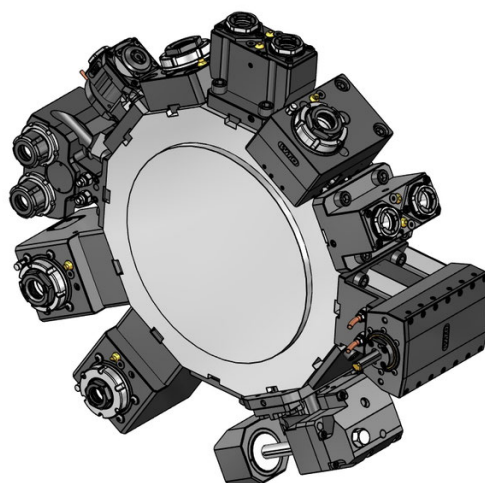
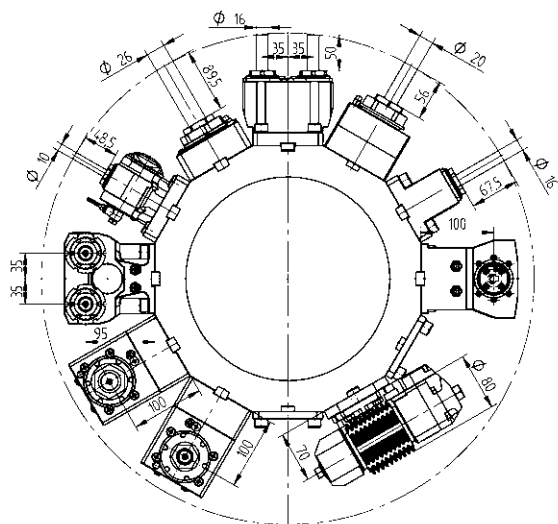

动力刀座 - QuickFlex®

动力刀座 - 扩展产品目录



直结式钻/铣动力刀座

- ER-32 QF QF32-DNE-BT65A-058-E-A 1:1 EC
0067732000
- ER-32 QF QF32-DNE-BT65A-060-I-A 1:1 IC 100 bar
0067732000



直结式钻/铣动力刀座 - QF smart (EU, US, CA, JP)

- ER-32 QF QF32-DNE-BT65A-060-I-SB-A 1:1 IC 100 bar
0067732000



直角式钻/铣动力刀座, LF=100

- ER-32 QF 420532018-65 1:1 EC
0067732000
- ER-32 QF QF32-DNI-BT65A-100-I-A 1:1 IC 100 bar
0067732000



直角式钻/铣动力刀座 - QF smart (EU, US, CA, JP), LF=100

- ER-32 QF QF32-DNI-BT65A-100-I-SB-A 1:1 IC 100 bar
0067732000



直角式钻/铣动力刀座, 两侧的, LF=100

- ER-32 QF 420532020-65 1:1 EC
0067732000



直结式钻/铣动力刀座

- ER 40 ER40-DNE-BT65A-084-E-A 1:1 EC
00675000079
- ER 40 ER40-DNE-BT65A-086-I-A 1:1 IC 100 bar
00675000079



直结偏位式钻/铣动力刀座

- ER-32 QF 420132037-65 1:1 EC
0067732000
- ER-32 QF 420132038-65 1:1 IC 80 bar
0067732000
- ER-25 QF 420125010-65 1:2 EC
0067725001
- ER-25 QF 420125011-65 1:2 IC 80 bar
0067725001



直角式钻/铣动力刀座, LF=100

- ER 40 410526007-65 1:1 EC
00675000079
- ER 40 410526008-65 1:1 IC 80 bar
00675000079

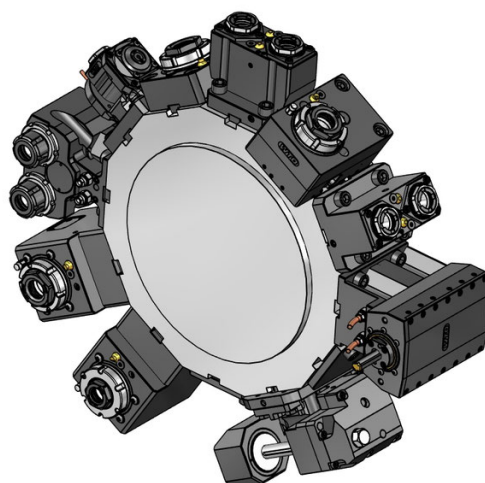
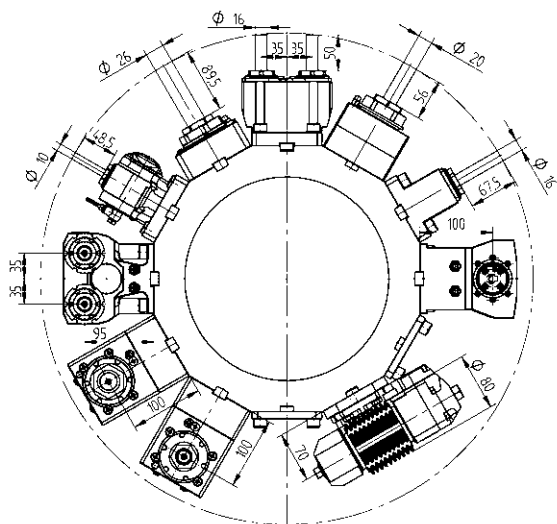

动力刀座 - 扩展产品目录

动力刀座 - 扩展产品目录



直角式钻/铣动力刀座, LF=100

ER-25 QF	QF25-DNI-BT65A-100-E-S-A 0067725001	1:2	EC
ER-25 QF	QF25-DNI-BT65A-100-I-S-A 0067725001	1:2	IC 100 bar
ER-32 QF	QF32-DNI-BT65A-100-E-T-A 0067732000	2:1	EC
ER-32 QF	QF32-DNI-BT65A-100-I-T-A 0067732000	2:1	IC 100 bar



直角后缩式钻/铣动力刀座

ER-32 QF	420532090-65 0067732000	1:1	EC
ER-32 QF	420532091-65 0067732000	1:1	IC 80 bar



可调角度钻/铣动力刀座

ER 16	411010002-65 00675000902	1:1	EC
ER 16	411010003-65 00675000902	1:1	IC 80 bar
ER 11	411007002-65 00675000914	1:2	EC
ER 11	411007003-65 00675000914	1:2	IC 80 bar



滚齿刀座

16-1 型式	411500003-65	1:1	EC
16-1 型式	411500002-65	2:1	EC
	00675000927		
	160016161 Ø 16		
	160022161 Ø 22		
	160027161 Ø 27		
	160015161 Ø 5/8"		
	160019161 Ø 3/4"		
	160025161 Ø 1"		
	160031161 Ø 1 1/4"		
	110587		



直结式钻/铣刀座, 两侧的

ER 25	413002005-65 00675000907	1:1	EC
-------	-----------------------------	-----	----



直结式钻/铣刀座, 2刀位, Y-轴

ER 25	413002004-65 00675000907	1:1	EC
-------	-----------------------------	-----	----

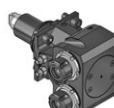

二轴直角式钻/铣动力刀座, Y-轴

ER 25	413502006-65 00675000915	1:1	EC
ER 25	413502007-65 00675000915	1:1	IC 80 bar

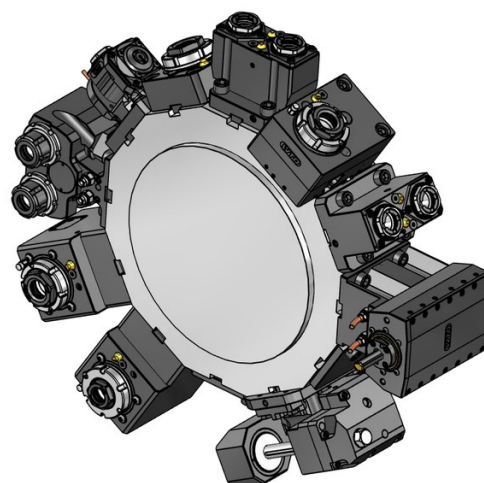
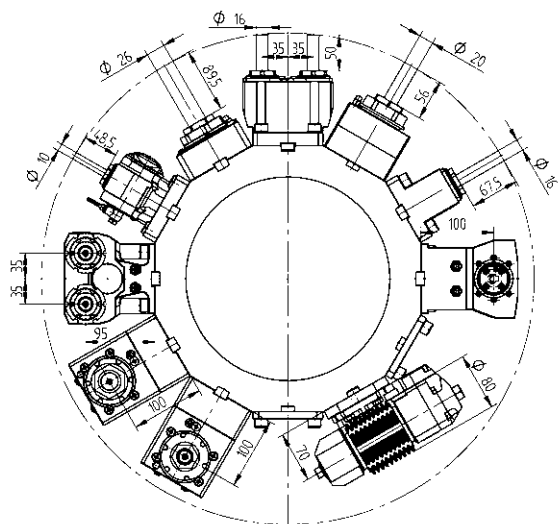

动力刀座 - 扩展产品目录



二轴直角式钻/铣动力刀座, 两侧的, Y-轴
 ER 25 413502008-65 1:1 EC
 00675000915



插槽刀座(内外径通用)
 32 型式 414532000-65 1:1 EC



插槽刀座(内外径通用)
 52 型式 414552000-65 1:1 EC

标准规格套筒 - 圆柱形



变径套 Ø 25

240025006	ø 6
240025008	ø 8
240025010	ø 10
240025012	ø 12
240025014	ø 14
240025016	ø 16
240025020	ø 20



变径套 Ø 32

240032006	ø 6
240032008	ø 8
240032010	ø 10
240032012	ø 12
240032014	ø 14
240032016	ø 16
240032018	ø 18
240032020	ø 20
240032025	ø 25



变径套 Ø 40

240040006	ø 6
240040008	ø 8
240040010	ø 10
240040012	ø 12
240040014	ø 14
240040016	ø 16
240040020	ø 20
240040025	ø 25
240040032	ø 32



变径套 Ø 50

240050010	ø 10
240050012	ø 12
240050016	ø 16
240050020	ø 20
240050025	ø 25
240050032	ø 32
240050040	ø 40



变径套 Ø 60

240060012	ø 12
240060016	ø 16
240060020	ø 20
240060025	ø 25
240060032	ø 32
240060040	ø 40
240060050	ø 50

标准规格套筒 - 圆柱形



变径套 Ø 80

240080020	ø 20
240080025	ø 25
240080032	ø 32
240080040	ø 40
240080050	ø 50
240080060	ø 60

标准规格套筒 - 莫氏锥度

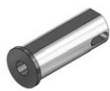

变径套 Ø 32

240532001	MT 1
240532002	MT 2
240532003	MT 3

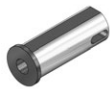

变径套 Ø 40

240540001	MT 1
240540002	MT 2
240540003	MT 3
240540004	MT 4

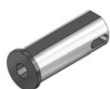

变径套 Ø 50

240550002	MT 2
240550003	MT 3
240550004	MT 4

筒夹 DIN 6499B (ER/ESX)



ER 11

190011000	ø 7-0.5	ø 0.276-0.020
190011010	ø 1-0.5	ø 0.039-0.020
190011015	ø 1.5-1	ø 0.059-0.039
190011020	ø 2-1.5	ø 0.079-0.059
190011025	ø 2.5-2	ø 0.098-0.079
190011030	ø 3-2.5	ø 0.118-0.098
190011035	ø 3.5-3	ø 0.138-0.118
190011040	ø 4-3.5	ø 0.158-0.138
190011045	ø 4.5-4	ø 0.177-0.158
190011050	ø 5-4.5	ø 0.197-0.177
190011055	ø 5.5-5	ø 0.217-0.197
190011060	ø 6-5.5	ø 0.236-0.217
190011065	ø 6.5-6	ø 0.256-0.236
190011070	ø 7-6.5	ø 0.276-0.256



ER 16

190016000	ø 10-0.5	ø 0.394-0.020
190016010	ø 1-0.5	ø 0.039-0.020
190016020	ø 2-1	ø 0.079-0.039
190016030	ø 3-2	ø 0.118-0.079
190016040	ø 4-3	ø 0.158-0.118
190016050	ø 5-4	ø 0.197-0.158
190016060	ø 6-5	ø 0.236-0.197
190016070	ø 7-6	ø 0.276-0.236
190016080	ø 8-7	ø 0.315-0.276
190016090	ø 9-8	ø 0.354-0.315
190016100	ø 10-9	ø 0.394-0.354



ER 20

190020000	ø 13-1	ø 0.512-0.039
190020010	ø 1-0.5	ø 0.039-0.020
190020020	ø 2-1	ø 0.079-0.039
190020030	ø 3-2	ø 0.118-0.079
190020040	ø 4-3	ø 0.157-0.118
190020050	ø 5-4	ø 0.197-0.157
190020060	ø 6-5	ø 0.236-0.197
190020070	ø 7-6	ø 0.276-0.236
190020080	ø 8-7	ø 0.315-0.276
190020090	ø 9-8	ø 0.354-0.315
190020100	ø 10-9	ø 0.394-0.354
190020110	ø 11-10	ø 0.433-0.394
190020120	ø 12-11	ø 0.472-0.433
190020130	ø 13-12	ø 0.512-0.472

筒夹 DIN 6499B (ER/ESX)



ER 25

190025000	ø 16-1	ø 0.630-0.039
190025010	ø 1-0.5	ø 0.039-0.020
190025020	ø 2-1	ø 0.079-0.039
190025030	ø 3-2	ø 0.118-0.079
190025040	ø 4-3	ø 0.157-0.118
190025050	ø 5-4	ø 0.197-0.157
190025060	ø 6-5	ø 0.236-0.197
190025070	ø 7-6	ø 0.276-0.236
190025080	ø 8-7	ø 0.315-0.276
190025090	ø 9-8	ø 0.354-0.315
190025100	ø 10-9	ø 0.394-0.354
190025110	ø 11-10	ø 0.433-0.394
190025120	ø 12-11	ø 0.472-0.433
190025130	ø 13-12	ø 0.512-0.472
190025140	ø 14-13	ø 0.551-0.512
190025150	ø 15-14	ø 0.591-0.551
190025160	ø 16-15	ø 0.630-0.591



ER 32

190032000	ø 20-2	ø 0.787-0.079
190032020	ø 2-1	ø 0.079-0.039
190032030	ø 3-2	ø 0.118-0.079
190032040	ø 4-3	ø 0.157-0.118
190032050	ø 5-4	ø 0.197-0.157
190032060	ø 6-5	ø 0.236-0.197
190032070	ø 7-6	ø 0.276-0.236
190032080	ø 8-7	ø 0.315-0.276
190032090	ø 9-8	ø 0.354-0.315
190032100	ø 10-9	ø 0.394-0.354
190032110	ø 11-10	ø 0.433-0.394
190032120	ø 12-11	ø 0.472-0.433
190032130	ø 13-12	ø 0.512-0.472
190032140	ø 14-13	ø 0.551-0.512
190032150	ø 15-14	ø 0.591-0.551
190032160	ø 16-15	ø 0.630-0.591
190032170	ø 17-16	ø 0.669-0.630
190032180	ø 18-17	ø 0.709-0.669
190032190	ø 19-18	ø 0.748-0.709
190032200	ø 20-19	ø 0.787-0.748

筒夹 DIN 6499B (ER/ESX)



ER 40

190040000	ø 26-3	ø 1.024-0.118
190040030	ø 3-2	ø 0.118-0.079
190040040	ø 4-3	ø 0.157-0.118
190040050	ø 5-4	ø 0.197-0.157
190040060	ø 6-5	ø 0.236-0.197
190040070	ø 7-6	ø 0.276-0.236
190040080	ø 8-7	ø 0.315-0.276
190040090	ø 9-8	ø 0.354-0.315
190040100	ø 10-9	ø 0.394-0.354
190040110	ø 11-10	ø 0.433-0.394
190040120	ø 12-11	ø 0.472-0.433
190040130	ø 13-12	ø 0.512-0.472
190040140	ø 14-13	ø 0.551-0.512
190040150	ø 15-14	ø 0.591-0.551
190040160	ø 16-15	ø 0.630-0.591
190040170	ø 17-16	ø 0.669-0.630
190040180	ø 18-17	ø 0.709-0.669
190040190	ø 19-18	ø 0.748-0.709
190040200	ø 20-19	ø 0.787-0.748
190040210	ø 21-20	ø 0.827-0.787
190040220	ø 22-21	ø 0.866-0.827
190040230	ø 23-22	ø 0.906-0.866
190040240	ø 24-23	ø 0.945-0.906
190040250	ø 25-24	ø 0.984-0.945
190040260	ø 26-25	ø 1.024-0.984



ER 50

190050000	ø 34-10	ø 1.339-0.394
190050060	ø 6-4	ø 0.236-0.157
190050080	ø 8-6	ø 0.315-0.236
190050100	ø 10-8	ø 0.394-0.315
190050120	ø 12-10	ø 0.472-0.394
190050140	ø 14-12	ø 0.551-0.472
190050160	ø 16-14	ø 0.630-0.551
190050180	ø 18-16	ø 0.709-0.630
190050200	ø 20-18	ø 0.787-0.709
190050220	ø 22-20	ø 0.866-0.787
190050240	ø 24-22	ø 0.945-0.866
190050260	ø 26-24	ø 1.024-0.945
190050280	ø 28-26	ø 1.102-1.024
190050300	ø 30-28	ø 1.181-1.102
190050320	ø 32-30	ø 1.260-1.181
190050340	ø 32-30	ø 1.260-1.181

筒夹 DIN 6499D (ER/ESX) - 密封, 为内冷系统



ER 11

191011030	ø 3
191011040	ø 4
191011050	ø 5
191011060	ø 6



ER 16

191016000	ø 3-10
191016030	ø 3
191016040	ø 4
191016050	ø 5
191016060	ø 6
191016070	ø 7
191016080	ø 8
191016090	ø 9
191016100	ø 10



ER 20

191020000	ø 3-12
191020030	ø 3
191020040	ø 4
191020050	ø 5
191020060	ø 6
191020070	ø 7
191020080	ø 8
191020090	ø 9
191020100	ø 10
191020110	ø 11
191020120	ø 12



ER 25

191025000	ø 4-16
191025030	ø 3
191025040	ø 4
191025050	ø 5
191025060	ø 6
191025070	ø 7
191025080	ø 8
191025090	ø 9
191025100	ø 10
191025110	ø 11
191025120	ø 12
191025130	ø 13
191025140	ø 14
191025150	ø 15
191025160	ø 16

筒夹 DIN 6499D (ER/ESX) - 密封, 为内冷系统



ER 32

191032000	ø 4-20
191032030	ø 3
191032040	ø 4
191032050	ø 5
191032060	ø 6
191032070	ø 7
191032080	ø 8
191032090	ø 9
191032100	ø 10
191032110	ø 11
191032120	ø 12
191032130	ø 13
191032140	ø 14
191032150	ø 15
191032160	ø 16
191032170	ø 17
191032180	ø 18
191032190	ø 19
191032200	ø 20



ER 40

191040060	ø 6
191040080	ø 8
191040100	ø 10
191040120	ø 12
191040140	ø 14
191040160	ø 16
191040180	ø 18
191040200	ø 20
191040220	ø 22
191040250	ø 25

WTO 全球分布

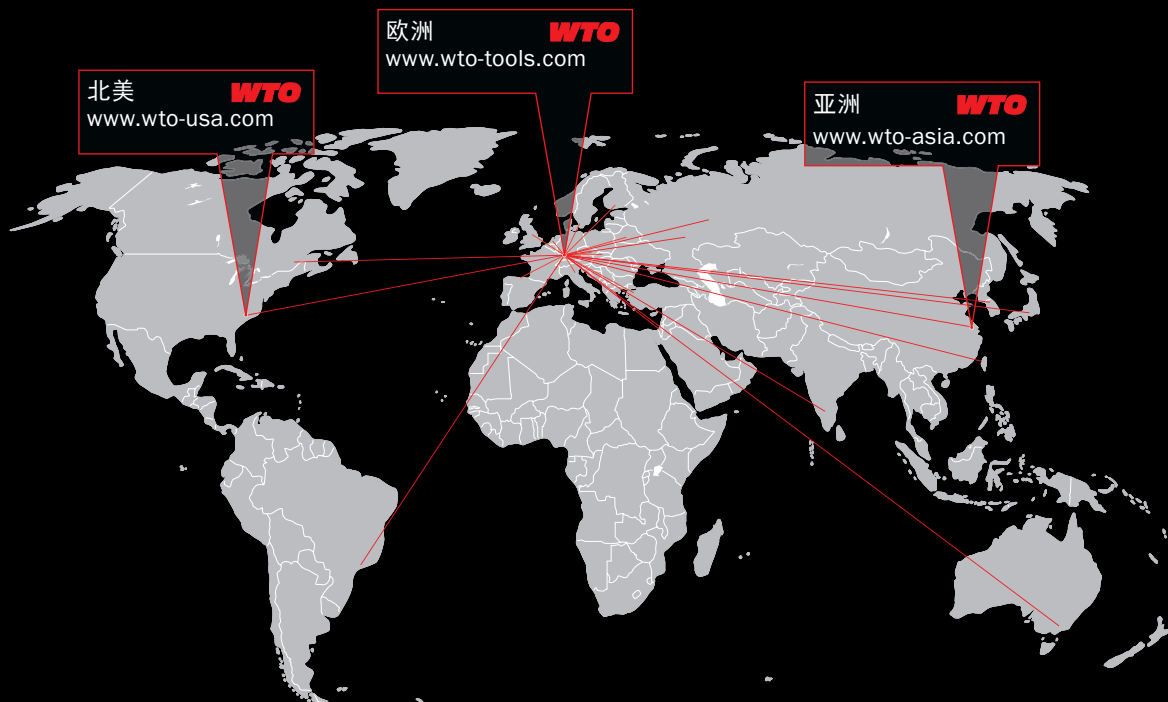

北美
www.wto-usa.com

欧洲
www.wto-tools.com

亚洲
www.wto-asia.com

WTO Werkzeug-
Einrichtungen GmbH
有限公司
Neuer Hohdammweg 1
77797 Ohlsbach
德国

WTO Inc. 美国分公司
13900-F South Lakes Dr.
Charlotte, NC 28273
美国

WTO 亚洲
上海市松江区九亭镇
伴亭路228号2号楼
109-110 室
邮编: 201615 上海
中国

在您所在地的WTO得力的销售伙伴为您提供产品咨询服务

澳大利亚
Dimac Tooling Ltd.
sales@dimac.com.au

英国
Cutwel Ltd.
sales@cutwel.net

韩国
WTO Office Korea
is.chon@wto-korea.com

瑞士
Utilis AG
info@utilis.com

巴西
TF2
tfdois@tfdois.com.br

匈牙利
Prevotex Hungary Kft.
info@prevotex.hu

墨西哥
Workholding Engineering De México
info@wem.com.mx

斯洛伐克
ALBA precision s.r.o.
albabprecision@albabprecision.sk

中国
Shanghai Gangde
wtocando@yahoo.com

印度
Ulhas Patil
u.patil@wto-asia.com

荷兰
Toologic BeNeLux B.V.
info@toologic-benelux.nl

西班牙
ITALMATIC, S.A.
italmatic@italmatic.es

丹麦
AVN Teknik A/S
cjo@avn.dk

以色列
E.Y.A.R. Ltd.
boris@eyar.co.il

挪威
Helge Karlsen Verktøy og Maskin AS
hkvm@hkvm.no

台湾
Kaiko Co., Ltd.
info@kaiko.com.tw

芬兰
Suomen Terätuonti Oy
myynti@stt.as

意大利
Prymark srl
commerciale@prymark.it

波兰
ARCO Andrzej Rudenko
info@arcotools.pl

土耳其
MYK CNC MAKINA SAN. VE
huseyin.tatlidil@mykcnc.com.tr

法国东部
Alexandre Mathelin
alm@wto.de

日本
NK Works Co. Ltd.
k_samba@nk-works.co.jp

罗马尼亚
SC Elif Trading SRL
bulent.ozkan@eliftrading.com

捷克
ALBA precision, spol. s.r.o.
info@albabprecision.cz

法国, 西部
Christophe Archambault
car@wto.de

加拿大
Mittmann Industrial Inc.
info@mittmann.com

瑞典
Bonhron & Ewing AB
info@bonhron-ewing.se

乌克兰
„LLC“ SPA Stankopromimport
info@phoenix-ua.com

商标WTO、QuickFlex和nanoFlex属于WTO Vermögensverwaltung GmbH所有。
商标CoolSpeed属于WTO公司所有。