

Programma Portautensili

GLS-150, 200 M/Y (torretta nuova versione)

GLS-1500, 2000 M/LY/LMS/LYS

GLS-2800-3300 M/Y/MS/YS

GMS-2000 ST (torretta a 15 stazioni)

GMT-2000

GS-200-280 M/MS, GA-2000-3600 M

GS-400, 600, 6000, 6600, 8000, 8800 M

GS-2000 - 4000 M/Y/MS/YS (torretta a 12 stazioni)

GS-2000 - 3300 M/Y/MS/YS (torretta a 16 stazioni)

GTS-150 MMX/XY (torretta nuova versione)

GTS-200, 260 MMX/XY (torretta nuova versione)

GTX/GTZ-2000, 2600 M/Y (torretta a 12 stazioni)

GTX/GTZ-2000, 2600 M/Y (torretta a 16 stazioni)

GTZ-1500Y

GV-500, 780 M

GV-800, 1000 M

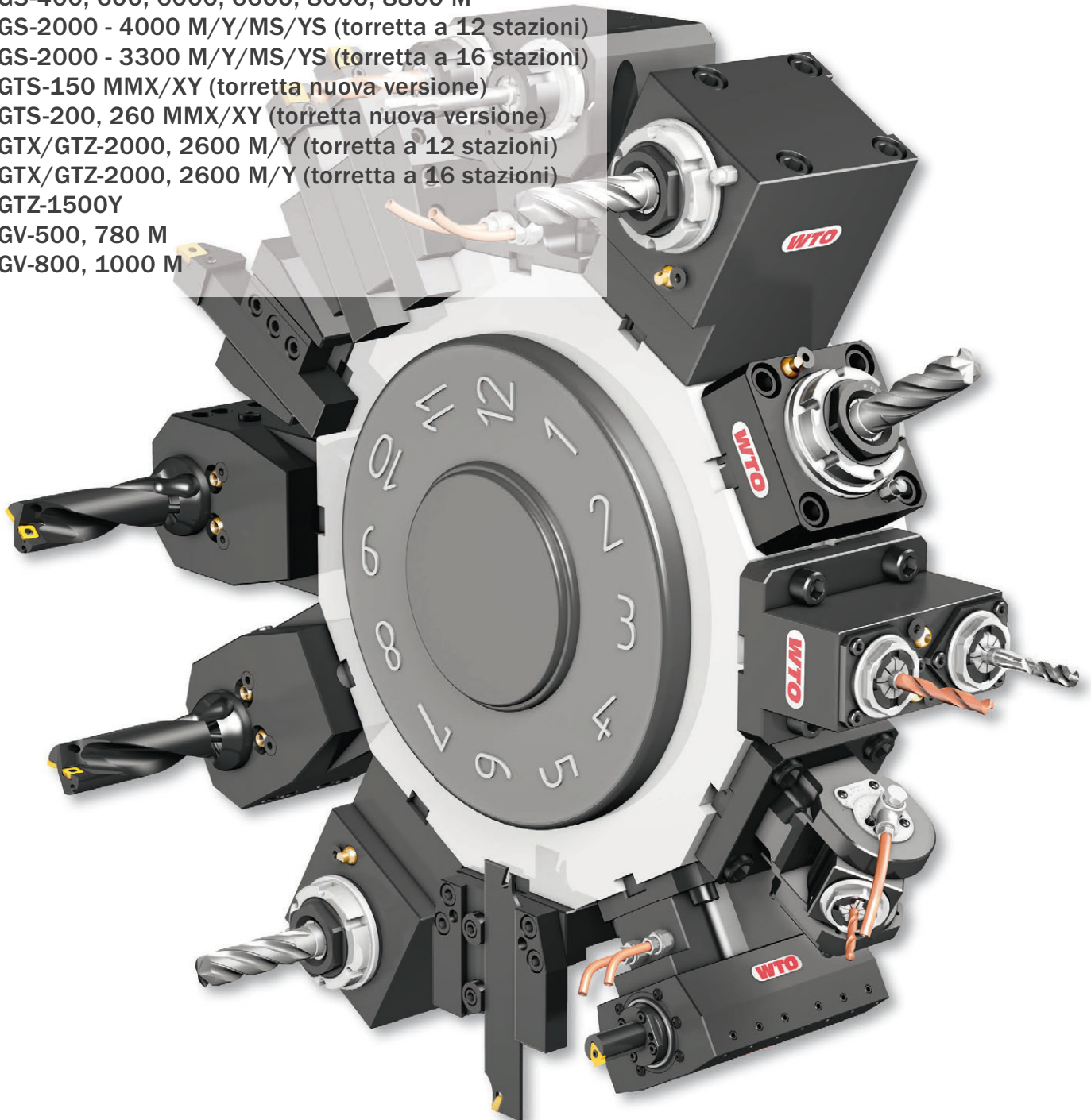

QuickFlex®

Nuovo sistema a cambio rapido per elevate prestazioni e precisione.

Minimo investimento, massima versatilità.



progettato per
torrette BMT

GLS-150, 200 M/Y (torretta nuova versione)	Pagina 4 - 6
GLS-1500, 2000 M/LY/LMS/LYS	Pagina 7 - 9
GLS-2800-3300 M/Y/MS/YS	Pagina 10 - 13
GMS-2000 ST (torretta a 15 stazioni)	Pagina 14 - 17
GMT-2000	Pagina 18 - 22
GS-200-280 M/MS, GA-2000-3600 M	Pagina 23 - 27
GS-400, 600, 6000, 6600, 8000, 8800 M	Pagina 28 - 28
GS-2000 - 4000 M/Y/MS/YS (torretta a 12 stazioni)	Pagina 29 - 32
GS-2000 - 3300 M/Y/MS/YS (torretta a 16 stazioni)	Pagina 33 - 37
GTS-150 MMX/XY (torretta nuova versione)	Pagina 38 - 40
GTS-200, 260 MMX/XY (torretta nuova versione)	Pagina 41 - 42
GTX/GTZ-2000, 2600 M/Y (torretta a 12 stazioni)	Pagina 43 - 46
GTX/GTZ-2000, 2600 M/Y (torretta a 16 stazioni)	Pagina 47 - 49
GTZ-1500Y	Pagina 50 - 52
GV-500, 780 M	Pagina 53 - 53
GV-800, 1000 M	Pagina 54 - 54
Pinze	Pagina 58 - 60

EC = adduzione esterna refrigerante
HP-IC = adduzione interna refrigerante alta pressione attraverso l'utensile
IC 80 bar = adduzione esterna ed interna refrigerante
Massima pressione refrigerante = 80 bar
IC 30 bar = adduzione esterna ed interna refrigerante
Massima pressione refrigerante = 30 bar
usare solo refrigerante filtrato (dim. Max. =50 µm)
non utilizzare senza refrigerante!
non utilizzare per lavorazione di ghise

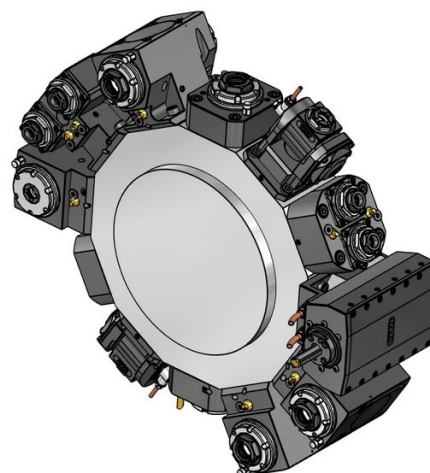
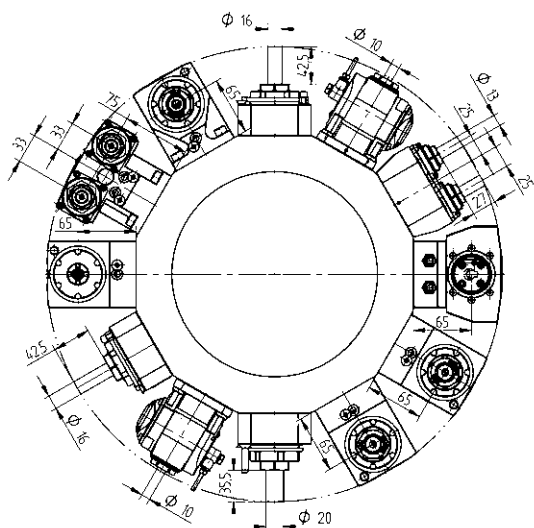

Portautensili Rotanti - QuickFlex®



Portautensile rotante di foratura/fresatura

- | | | | |
|-----------------|--------------|-----|-----------|
| ER-25 QF | 420125010-45 | 1:1 | EC |
| | 0067725000 | | |
| ER-25 QF | 420125011-45 | 1:1 | IC 80 bar |
| | 0067725000 | | |



Portautensile rotante di foratura/fresatura

- | | | | |
|-----------------|--------------|-----|-----------|
| ER-25 QF | 420525010-45 | 1:1 | EC |
| | 0067725000 | | |
| ER-25 QF | 420525011-45 | 1:1 | IC 80 bar |
| | 0067725000 | | |

Portautensili Rotanti - Estensione del programma



Portautensile rotante di foratura/fresatura

- | | | | |
|--------------|--------------|-----|-----------|
| ER 32 | 410120002-45 | 1:1 | EC |
| | 0067525000 | | |
| ER 32 | 410120003-45 | 1:1 | IC 80 bar |
| | 0067525000 | | |



Portautensile rotante di foratura/fresatura, disassato

- | | | | |
|--------------|--------------|-------|-----------|
| ER 25 | 410116006-45 | 1:1 | EC |
| | 00675000932 | | |
| ER 25 | 410116007-45 | 1:1 | IC 80 bar |
| | 00675000932 | | |
| ER 20 | 410113002-45 | 1:2 | EC |
| | 00675000939 | | |
| ER 20 | 410113003-45 | 1:2 | IC 80 bar |
| | 00675000939 | | |
| ER 16 | 410110000-45 | 1:3 | EC |
| | 00675000937 | | |
| ER 16 | 410110001-45 | 1:3 | IC 80 bar |
| | 00675000937 | | |
| ER 25 | 410116008-45 | 1,5:1 | EC |
| | 00675000932 | | |
| ER 25 | 410116009-45 | 1,5:1 | IC 80 bar |
| | 00675000932 | | |

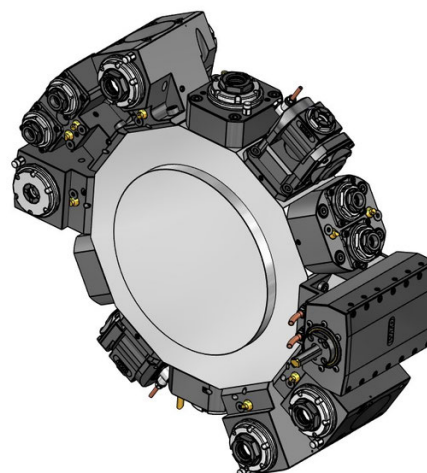
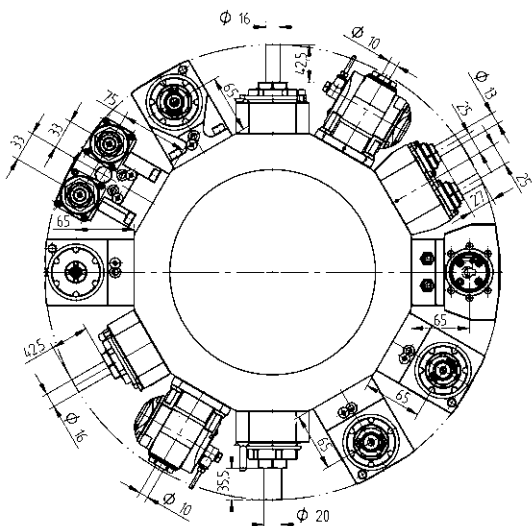

Portautensili Rotanti - Estensione del programma

Portautensili Rotanti - Estensione del programma

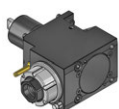

Portautensile rotante di foratura/fresatura

ER 32	410520010-45 0067725000	1:1	EC
ER 32	410520007-45 0067725000	1:1	IC 80 bar
ER-20 QF	420520010-45 0067720001	1:2	EC
ER-20 QF	420520011-45 0067720001	1:2	IC 80 bar
ER 16	410810002-45 00675000841	1:3	EC
ER 16	410810003-45 00675000841	1:3	IC 80 bar
ER-25 QF	420525013-45 0067725000	2:1	EC
ER-25 QF	420525014-45 0067725000	2:1	IC 80 bar
ER 32	410520008-45 00675000827	2:1	EC
ER 32	410520009-45 00675000827	2:1	IC 80 bar



Portautensile rotante portafrese a disco

Tipo 14-2	411500001-45 00675000489	2,73:1	EC
	160016142 Ø 16		
	160022142 Ø 22		
	160027142 Ø 27		
	160015142 Ø 5/8"		
	160019142 Ø 3/4"		
	160023142 Ø 7/8"		
	160025142 Ø 1"		



Unità porta creatore

Tipo 15-2	410900002-45 00675001015	1:1	EC
	160008152 Ø 8		
	160010152 Ø 10		
	160013152 Ø 13		
	160016152 Ø 16		
	160022152 Ø 22		
	160015152 Ø 5/8"		
	160019152 Ø 3/4"		
	110587		

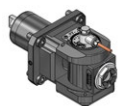

Portautensile rotante orientabile di foratura/fresatura

ER 16	411010000-45 00675000902	1:1	EC
ER 16	411010001-45 00675000902	1:1	IC 80 bar
ER 11	411007000-45 00675000914	1:2	EC
ER 11	411007001-45 00675000914	1:2	IC 80 bar



Portautensile rotante di foratura/fresatura - doppio, asse Y

ER 20	413002007-45 00675001016	1:1	EC
--------------	-----------------------------	-----	----

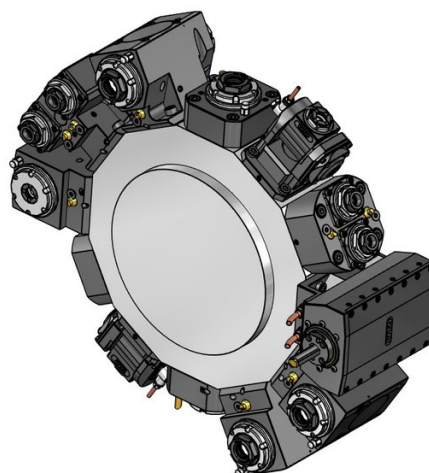
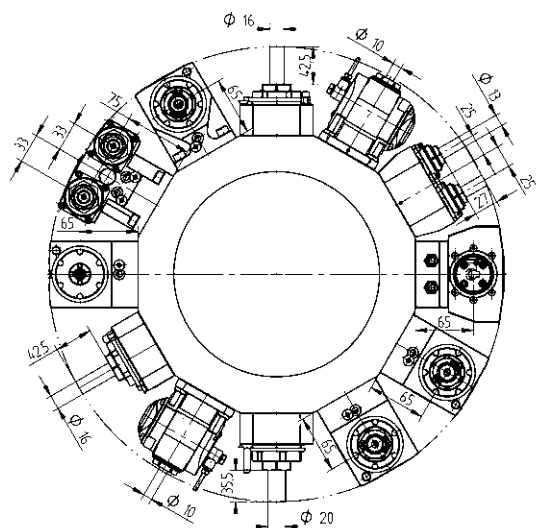

Portautensili Rotanti - Estensione del programma



Portautensile rotante di foratura/fresatura a 2 uscite, asse Y

ER 20

413502000-45

1:1 EC

 00675001016



Unità di brocciatura per interni ed esterni

TN765050

414532001-45

1:1 EC

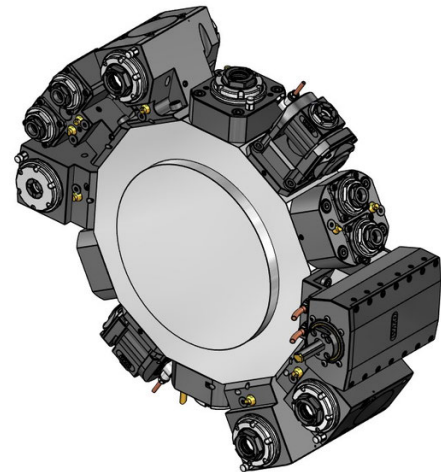
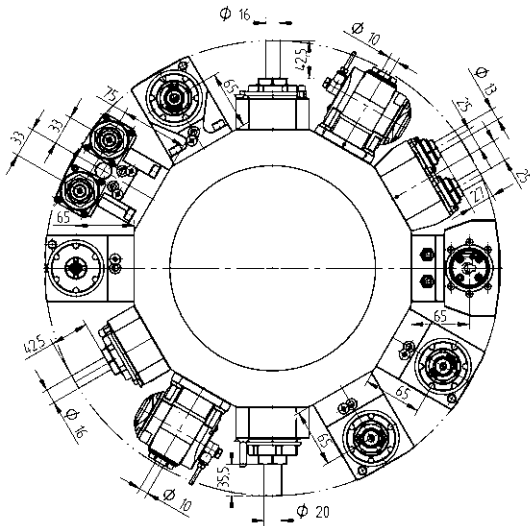

Portautensili Rotanti - QuickFlex®



Portautensile rotante di foratura/fresatura

- | | | | |
|-----------------|--------------|-----|-----------|
| ER-25 QF | 420125010-45 | 1:1 | EC |
| | 0067725000 | | |
| ER-25 QF | 420125011-45 | 1:1 | IC 80 bar |
| | 0067725000 | | |



Portautensile rotante di foratura/fresatura

- | | | | |
|-----------------|--------------|-----|-----------|
| ER-25 QF | 420525010-45 | 1:1 | EC |
| | 0067725000 | | |
| ER-25 QF | 420525011-45 | 1:1 | IC 80 bar |
| | 0067725000 | | |



Portautensile rotante di foratura/fresatura, per lavorazione su mandrino e contromandrino

- | | | | |
|-----------------|--------------|-----|----|
| ER-25 QF | 420525012-45 | 1:1 | EC |
| | 0067725000 | | |

Portautensili Rotanti - Estensione del programma



Portautensile rotante di foratura/fresatura

- | | | | |
|--------------|--------------|-----|-----------|
| ER 32 | 410120002-45 | 1:1 | EC |
| | 0067525000 | | |
| ER 32 | 410120003-45 | 1:1 | IC 80 bar |
| | 0067525000 | | |



Portautensile rotante di foratura/fresatura, disassato

- | | | | |
|--------------|--------------|-------|-----------|
| ER 25 | 410116006-45 | 1:1 | EC |
| | 00675000932 | | |
| ER 25 | 410116007-45 | 1:1 | IC 80 bar |
| | 00675000932 | | |
| ER 20 | 410113002-45 | 1:2 | EC |
| | 00675000939 | | |
| ER 20 | 410113003-45 | 1:2 | IC 80 bar |
| | 00675000939 | | |
| ER 16 | 410110000-45 | 1:3 | EC |
| | 00675000937 | | |
| ER 16 | 410110001-45 | 1:3 | IC 80 bar |
| | 00675000937 | | |
| ER 25 | 410116008-45 | 1,5:1 | EC |
| | 00675000932 | | |
| ER 25 | 410116009-45 | 1,5:1 | IC 80 bar |
| | 00675000932 | | |

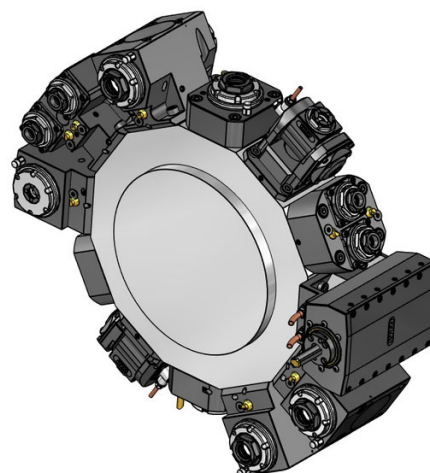
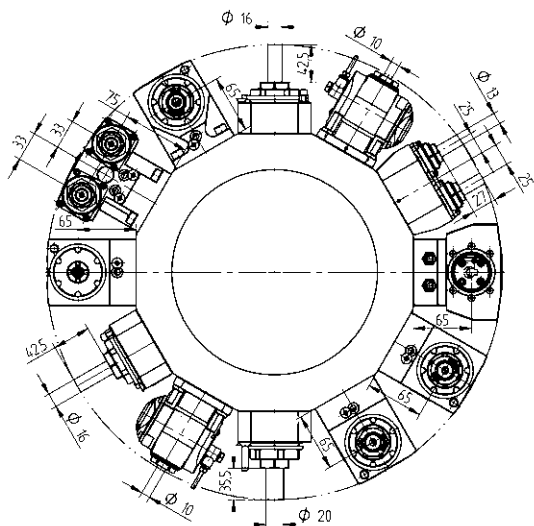

Portautensili Rotanti - Estensione del programma

Portautensili Rotanti - Estensione del programma

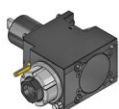

Portautensile rotante di foratura/fresatura

ER 32	410520010-45 0067725000	1:1	EC
ER 32	410520007-45 0067725000	1:1	IC 80 bar
ER-20 QF	420520010-45 0067720001	1:2	EC
ER-20 QF	420520011-45 0067720001	1:2	IC 80 bar
ER 16	410810002-45 00675000841	1:3	EC
ER 16	410810003-45 00675000841	1:3	IC 80 bar
ER-25 QF	420525013-45 0067725000	2:1	EC
ER-25 QF	420525014-45 0067725000	2:1	IC 80 bar
ER 32	410520008-45 00675000827	2:1	EC
ER 32	410520009-45 00675000827	2:1	IC 80 bar



Portautensile rotante portafrese a disco

Tipo 14-2	411500001-45 00675000489	2,73:1	EC
	160016142 Ø 16		
	160022142 Ø 22		
	160027142 Ø 27		
	160015142 Ø 5/8"		
	160019142 Ø 3/4"		
	160023142 Ø 7/8"		
	160025142 Ø 1"		



Unità porta creatore

Tipo 15-2	410900002-45 00675001015	1:1	EC
	160008152 Ø 8		
	160010152 Ø 10		
	160013152 Ø 13		
	160016152 Ø 16		
	160022152 Ø 22		
	160015152 Ø 5/8"		
	160019152 Ø 3/4"		
	110587		



Portautensile rotante orientabile di foratura/fresatura

ER 16	411010000-45 00675000902	1:1	EC
ER 16	411010001-45 00675000902	1:1	IC 80 bar
ER 11	411007000-45 00675000914	1:2	EC
ER 11	411007001-45 00675000914	1:2	IC 80 bar



Portautensile rotante di foratura/fresatura - doppio, asse Y

ER 20	413002007-45 00675001016	1:1	EC
--------------	-----------------------------	-----	----

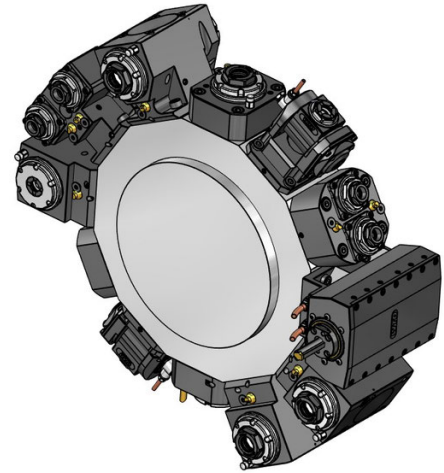
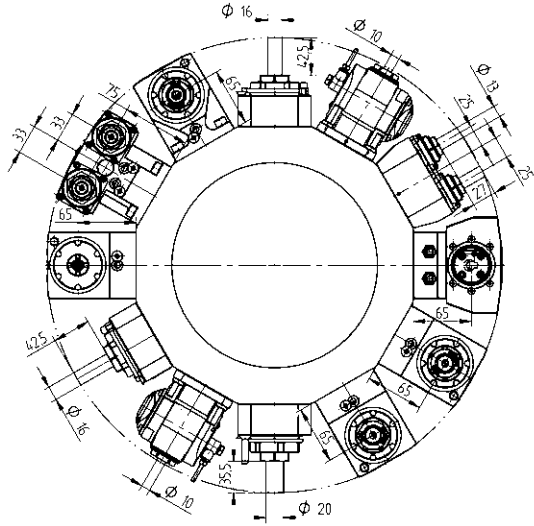

Portautensili Rotanti - Estensione del programma



Portautensile rotante di foratura/fresatura a 2 uscite, asse Y

ER 20 413502000-45 1:1 EC
00675001016

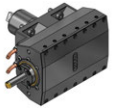

Unità di brocciatura per interni ed esterni

TN765050 414532001-45 1:1 EC

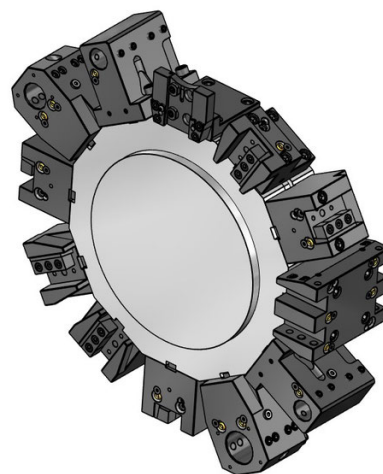
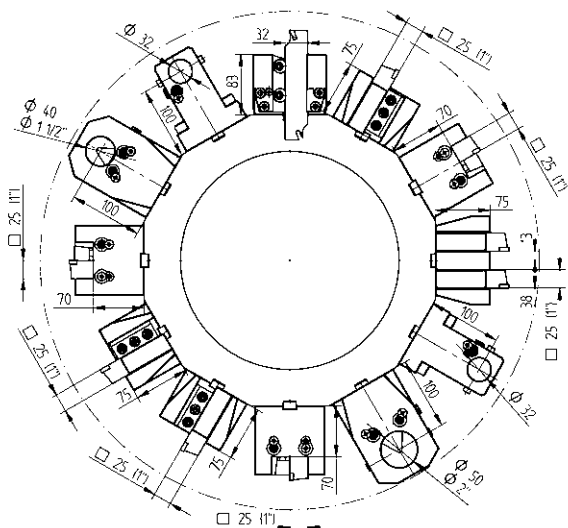

Portautensili statici - Programma standard

Portautensili statici - Programma standard



Portautensile

25 48-92428



Portautensile, HP-IC

25 48-92428-HP IC 80 bar



Portautensile per lavorazione su mandrino e contromandrino

25 48-92438



Portautensile per lavorazione su mandrino e contromandrino, HP-IC

25 48-92438-HP IC 80 bar



Portautensile per esterni

25 48-86719



Portautensile per esterni, HP-IC

25 48-109249-HP IC 80 bar



Portautensile combinato, LF=100

Ø 40 48-92397 IC 80 bar

241140020 ER32

241140026 ER40

Ø 50 48-92467 IC 80 bar

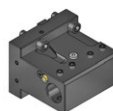

Portabareno per lavorazione su mandrino e contromandrino

Ø 32 48-101033



Coperchio di protezione

48-87089

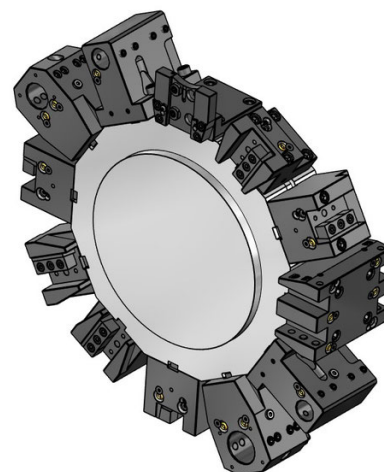
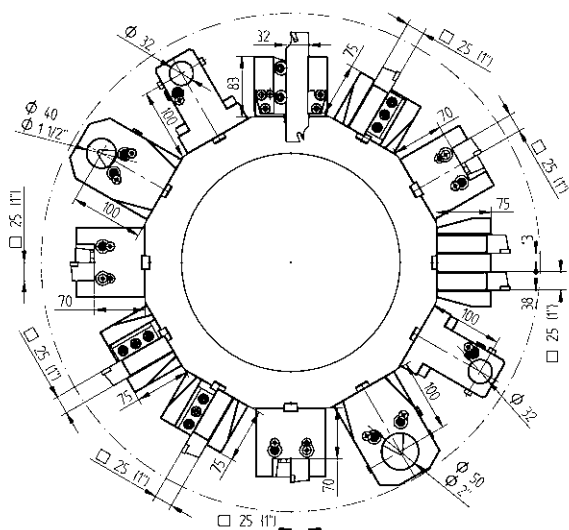

Portautensili statici - Estensione del programma



25(1")

Portautensile doppio, asse Y

48-86103



25(1")

Portautensile per lavorazione su mandrino e contromandrino, doppio, asse Y

48-86150



SH 32

Portautensile da taglio, con regolazione

48-99060



SH 32

Portautensile da taglio, con regolazione, HP-IC

48-102256R

IC 80 bar

48-102256L

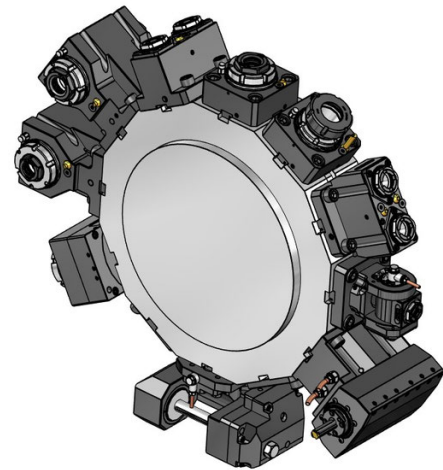
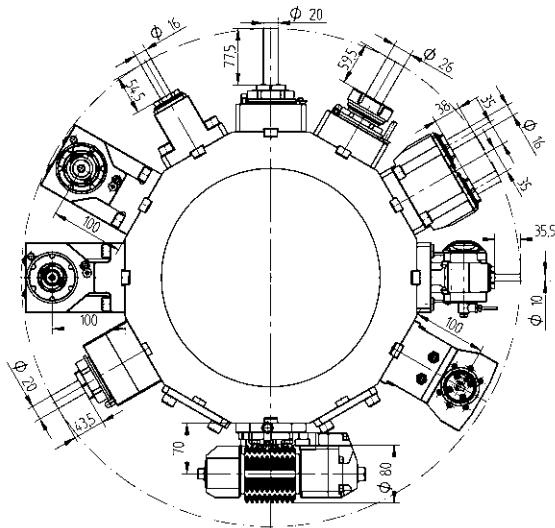

IC 80 bar

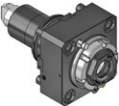

Portautensili Rotanti - QuickFlex®



- 

Portautensile rotante di foratura/fresatura

ER-32 QF	420132015-65	1:1	EC
	 0067732000		
ER-32 QF	420132016-65	1:1	IC 80 bar
	 0067732000		

- 

Portautensile rotante di foratura/fresatura, LF=100

ER-32 QF	420532018-65	1:1	EC
	 0067732000		
ER-32 QF	420532019-65	1:1	IC 80 bar
	 0067732000		

- 

Portautensile rotante radiale, per lavorazione su mandrino e contromandrino, LF=100

ER-32 QF	420532020-65	1:1	EC
	 0067732000		

Portautensili Rotanti - Estensione del programma

- 

Portautensile rotante di foratura/fresatura

ER 40	410126001-65	1:1	EC
	 00675000079		

- 

Portautensile rotante di fresatura con attacco combinato DIN 6358

Ø 22	410222002-65	1:1	EC
	 00675000483		

- 

Portautensile rotante di foratura/fresatura, disassato

ER-32 QF	420132037-65	1:1	EC
	 0067732000		
ER-32 QF	420132038-65	1:1	IC 80 bar
	 0067732000		
ER-25 QF	420125010-65	1:2	EC
	 0067725001		
ER-25 QF	420125011-65	1:2	IC 80 bar
	 0067725001		

- 

Portautensile rotante di foratura/fresatura, LF=100

ER 40	410526007-65	1:1	EC
	 00675000079		
ER 40	410526008-65	1:1	IC 80 bar
	 00675000079		

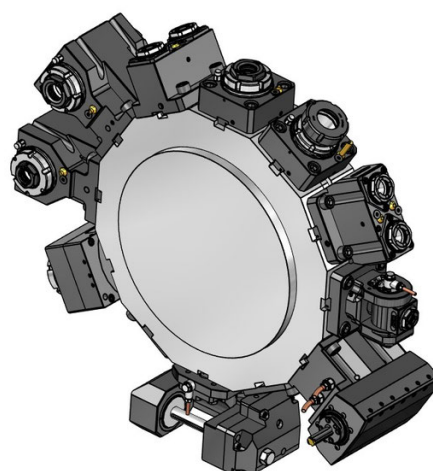
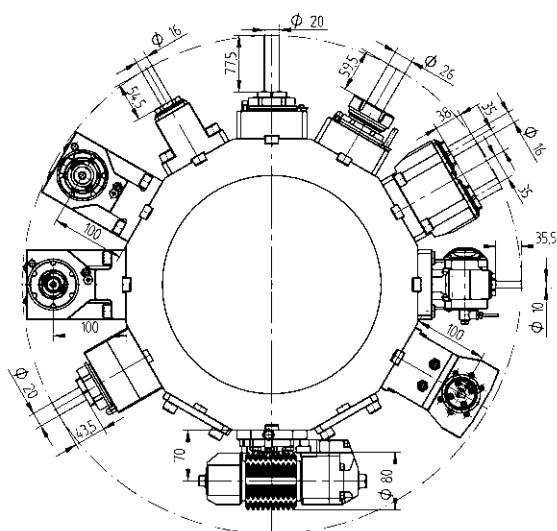

Portautensili Rotanti - Estensione del programma



Portautensile rotante di foratura/fresatura, LF=100

ER-25 QF	420525012-65 0067725001	1:2	EC
ER-25 QF	420525013-65 0067725001	1:2	IC 80 bar
ER-32 QF	420532029-65 0067732000	2:1	EC
ER-32 QF	420532030-65 0067732000	2:1	IC 80 bar



Portautensile rotante radiale portafrese combinato DIN6358, LF=100

Ø 22	410622002-65 00675000483	1:1	EC
-------------	-----------------------------	-----	----



Portautensile rotante orientabile di foratura/fresatura

ER 16	411010002-65 00675000902	1:1	EC
ER 16	411010003-65 00675000902	1:1	IC 80 bar
ER 11	411007002-65 00675000914	1:2	EC
ER 11	411007003-65 00675000914	1:2	IC 80 bar

Portautensili Rotanti - Estensione del programma



Unità porta creatore

Tipo 16-1	411500003-65	1:1	EC
Tipo 16-1	411500002-65	2:1	EC
	00675000927		
	160016161 Ø 16		
	160022161 Ø 22		
	160027161 Ø 27		
	160015161 Ø 5/8"		
	160019161 Ø 3/4"		
	160025161 Ø 1"		
	160031161 Ø 1 1/4"		
	110587		



Portautensile rotante di foratura e fresatura, per lavorazione su mandrino e contromandrino

ER 25	413002005-65	1:1	EC
	00675000907		



Portautensile rotante di foratura/fresatura - doppio, asse Y

ER 25	413002004-65	1:1	EC
	00675000907		

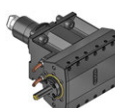

Unità di brocciatura per interni ed esterni

TN765050	414532000-65	1:1	EC
-----------------	--------------	-----	----

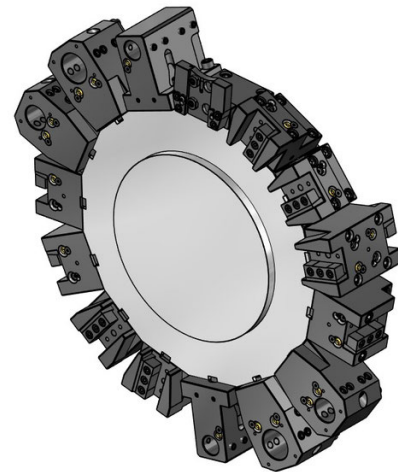
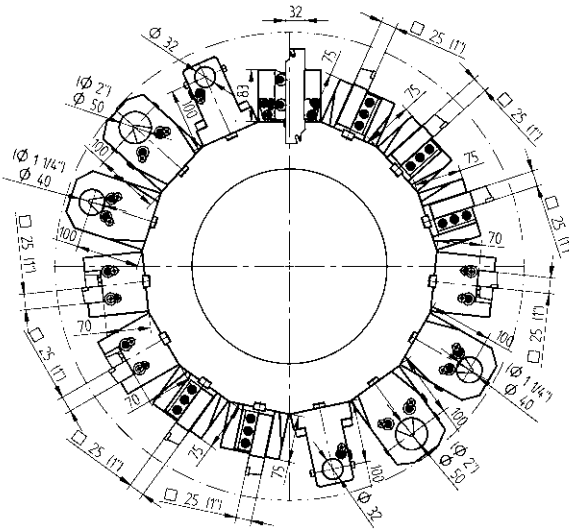

Portautensili statici - Programma standard

Portautensili statici - Programma standard



Portautensile

25 48-92428



Portautensile, HP-IC

25 48-92428-HP IC 80 bar



Portautensile per lavorazione su mandrino e contromandrino

25 48-92438



Portautensile per lavorazione su mandrino e contromandrino, HP-IC

25 48-92438-HP IC 80 bar



Portautensile per esterni

25 48-86719



Portautensile per esterni, HP-IC

25 48-109249-HP IC 80 bar



Portautensile combinato, LF=100

Ø 40 48-92397 IC 80 bar

 241140020 ER32

 241140026 ER40

Ø 50 48-92467 IC 80 bar



Portabareno per lavorazione su mandrino e contromandrino

Ø 32 48-101033



Coperchio di protezione

48-87089

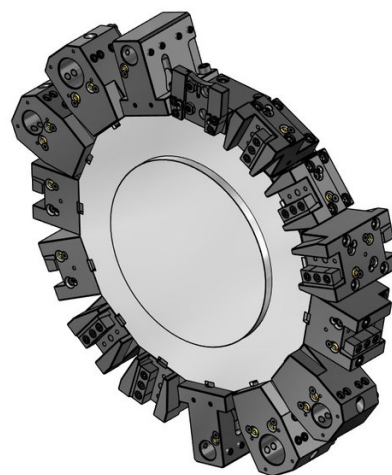
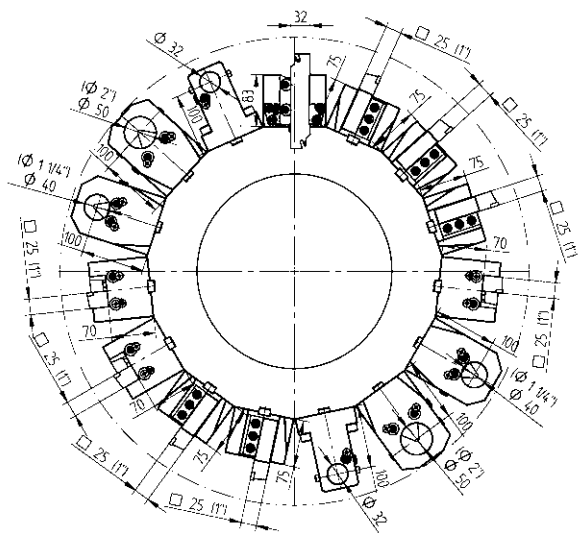

Portautensili statici - Estensione del programma



SH 32

Portautensile da taglio, con regolazione

48-99060



SH 32

Portautensile da taglio, con regolazione, HP-IC

48-102256R

IC 80 bar

SH 32

48-102256L

IC 80 bar

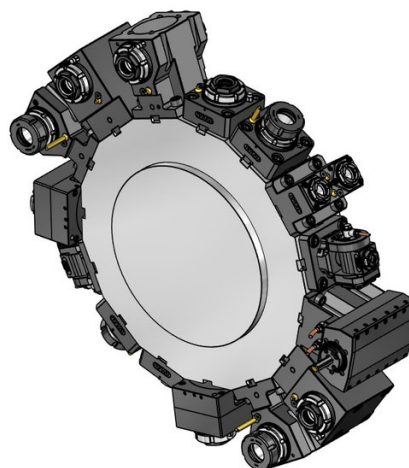
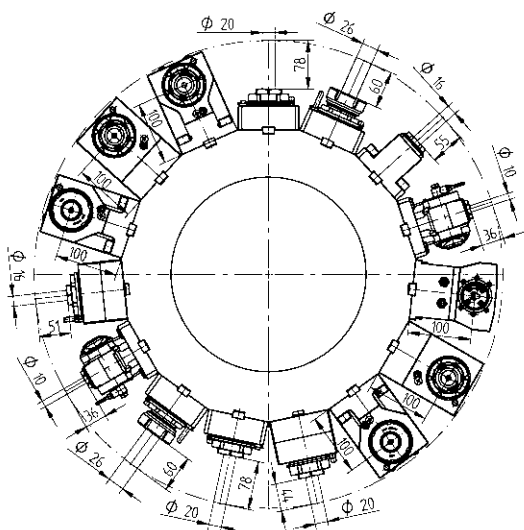

Portautensili Rotanti - QuickFlex®



Portautensile rotante di foratura/fresatura

ER-32 QF 420132015-65 1:1 EC
 0067732000

ER-32 QF 420132016-65 1:1 IC 80 bar
 0067732000



Portautensile rotante di foratura/fresatura, LF=100

ER-32 QF 420532018-65 1:1 EC
 0067732000

ER-32 QF 420532019-65 1:1 IC 80 bar
 0067732000



Portautensile rotante radiale, per lavorazione su mandrino e contromandrino, LF=100

ER-32 QF 420532020-65 1:1 EC
 0067732000

Portautensili Rotanti - Estensione del programma



Portautensile rotante di foratura/fresatura

ER 40 410126001-65 1:1 EC
 00675000079



Portautensile rotante di fresatura con attacco combinato DIN 6358

Ø 22 410222002-65 1:1 EC
 00675000483



Portautensile rotante di foratura/fresatura, disassato

ER-32 QF 420132037-65 1:1 EC
 0067732000

ER-32 QF 420132038-65 1:1 IC 80 bar
 0067732000

ER-25 QF 420125010-65 1:2 EC
 0067725001

ER-25 QF 420125011-65 1:2 IC 80 bar
 0067725001



Portautensile rotante di foratura/fresatura, LF=100

ER 40 410526007-65 1:1 EC
 00675000079

ER 40 410526008-65 1:1 IC 80 bar
 00675000079

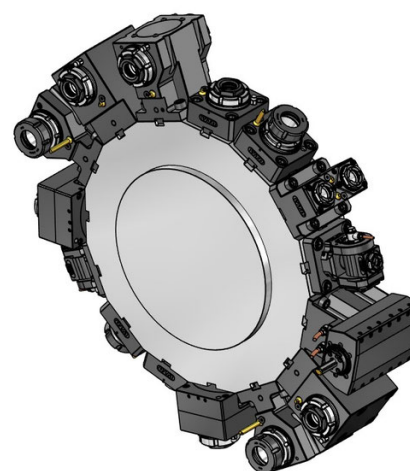
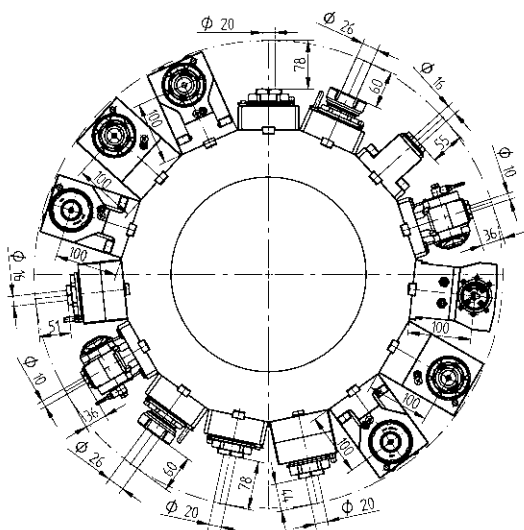

Portautensili Rotanti - Estensione del programma

Portautensili Rotanti - Estensione del programma



Portautensile rotante di foratura/fresatura, LF=100

ER-25 QF	420525012-65 0067725001	1:2	EC
ER-25 QF	420525013-65 0067725001	1:2	IC 80 bar
ER-32 QF	420532029-65 0067732000	2:1	EC
ER-32 QF	420532030-65 0067732000	2:1	IC 80 bar

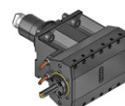

Unità di brocciatura per interni ed esterni

TN765050	414532000-65	1:1	EC
-----------------	--------------	-----	----



Portautensile rotante radiale portafrese combinato DIN6358, LF=100

Ø 22	410622002-65 00675000483	1:1	EC
-------------	-----------------------------	-----	----



Portautensile rotante orientabile di foratura/fresatura

ER 16	411010002-65 00675000902	1:1	EC
ER 16	411010003-65 00675000902	1:1	IC 80 bar
ER 11	411007002-65 00675000914	1:2	EC
ER 11	411007003-65 00675000914	1:2	IC 80 bar



Portautensile rotante di foratura e fresatura, per lavorazione su mandrino e contromandrino

ER 25	413002005-65 00675000907	1:1	EC
--------------	-----------------------------	-----	----

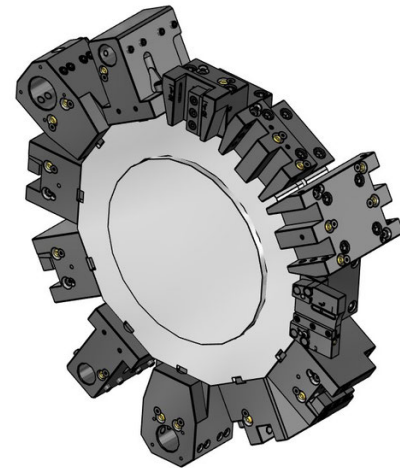
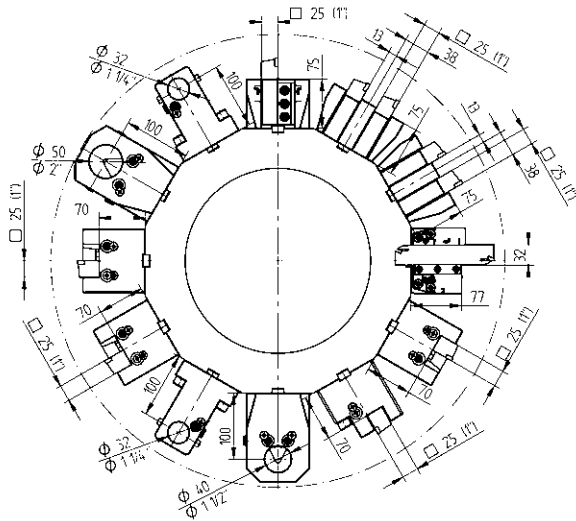

Portautensili statici - Programma standard

Portautensili statici - Programma standard



Portautensile

25 48-92428



Portautensile, HP-IC

25 48-92428-HP IC 80 bar



Portautensile per lavorazione su mandrino e contromandrino

25 48-92438



Portautensile per lavorazione su mandrino e contromandrino, HP-IC

25 48-92438-HP IC 80 bar



Portautensile per esterni

25 48-86719



Portautensile per esterni, HP-IC

25 48-109249-HP IC 80 bar



Portautensile combinato, LF=100

Ø 40 48-92397 IC 80 bar

 241140020 ER32

 241140026 ER40

Ø 50 48-92467 IC 80 bar



Portabareno per lavorazione su mandrino e contromandrino

Ø 32 48-101033



Coperchio di protezione

48-87089

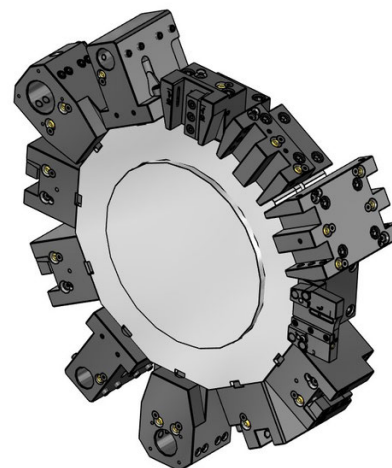
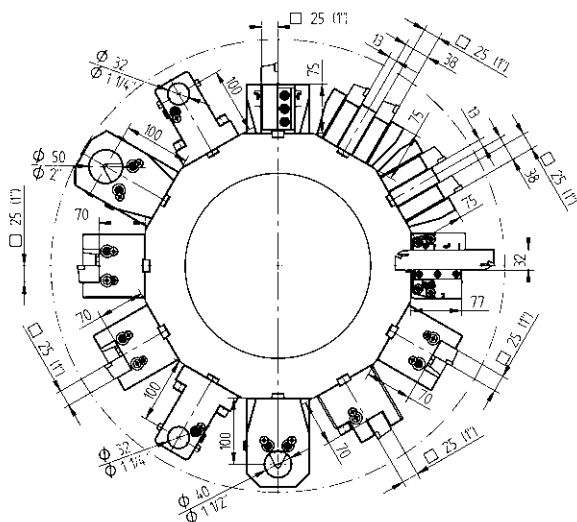

Portautensili statici - Estensione del programma



25(1")

Portautensile doppio, asse Y

48-86103



25(1")

Portautensile per lavorazione su mandrino e contromandrino, doppio, asse Y

48-86150



SH 32

Portautensile da taglio, con regolazione

48-99060



SH 32

Portautensile da taglio lungo, con regolazione

48-100084



SH 32

Portautensile da taglio, con regolazione, HP-IC

48-102256R

IC 80 bar

SH 32

48-102256L

IC 80 bar



SH 32

Portautensile da taglio lungo, con regolazione, HP-IC

48-100082R

IC 80 bar

SH 32

48-100082L

IC 80 bar

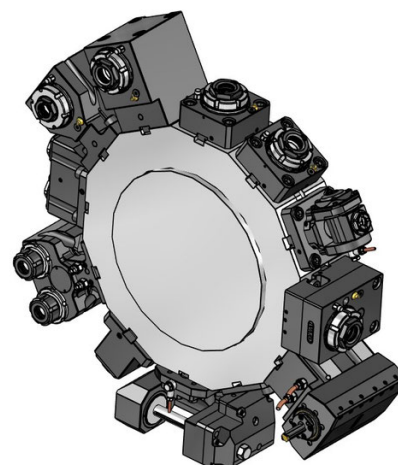
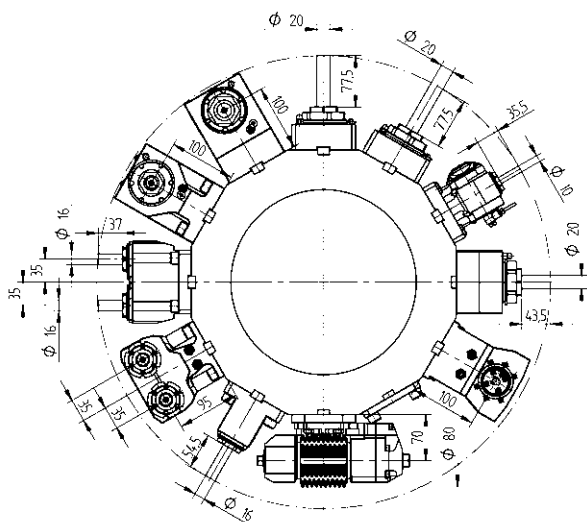

Portautensili Rotanti - QuickFlex®



Portautensile rotante di foratura/fresatura

ER-32 QF 420132015-65 1:1 EC
 0067732000

ER-32 QF 420132016-65 1:1 IC 80 bar
 0067732000



Portautensile rotante di foratura/fresatura, LF=100

ER-32 QF 420532018-65 1:1 EC
 0067732000

ER-32 QF 420532019-65 1:1 IC 80 bar
 0067732000



Portautensile rotante radiale, per lavorazione su mandrino e contromandrino, LF=100

ER-32 QF 420532020-65 1:1 EC
 0067732000

Portautensili Rotanti - Estensione del programma



Portautensile rotante di foratura/fresatura

ER 40 410126001-65 1:1 EC
 00675000079



Portautensile rotante di fresatura con attacco combinato DIN 6358

Ø 22 410222002-65 1:1 EC
 00675000483



Portautensile rotante di foratura/fresatura, disassato

ER-32 QF 420132037-65 1:1 EC
 0067732000

ER-32 QF 420132038-65 1:1 IC 80 bar
 0067732000

ER-25 QF 420125010-65 1:2 EC
 0067725001

ER-25 QF 420125011-65 1:2 IC 80 bar
 0067725001



Portautensile rotante di foratura/fresatura, LF=100

ER 40 410526007-65 1:1 EC
 00675000079

ER 40 410526008-65 1:1 IC 80 bar
 00675000079

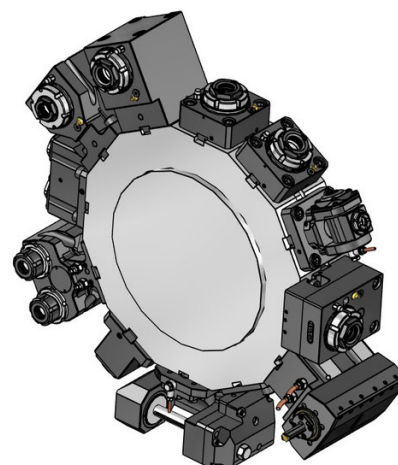
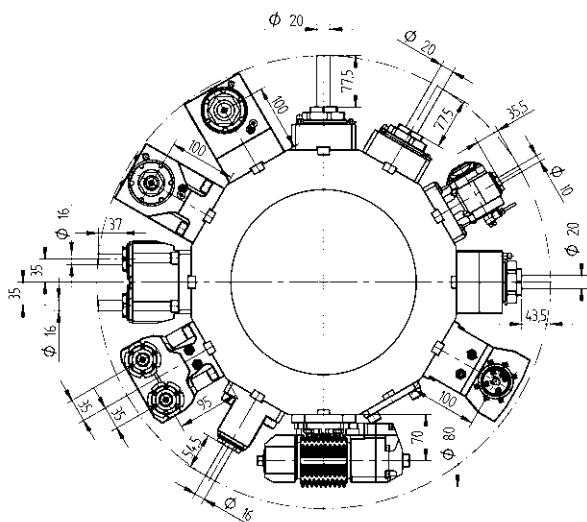

Portautensili Rotanti - Estensione del programma



Portautensile rotante di foratura/fresatura, LF=100

ER-25 QF	420525012-65 0067725001	1:2	EC
ER-25 QF	420525013-65 0067725001	1:2	IC 80 bar
ER-32 QF	420532029-65 0067732000	2:1	EC
ER-32 QF	420532030-65 0067732000	2:1	IC 80 bar



Portautensile rotante radiale portafrese combinato DIN6358, LF=100

Ø 22	410622002-65 00675000483	1:1	EC
-------------	-----------------------------	-----	----



Portautensile rotante orientabile di foratura/fresatura

ER 16	411010002-65 00675000902	1:1	EC
ER 16	411010003-65 00675000902	1:1	IC 80 bar
ER 11	411007002-65 00675000914	1:2	EC
ER 11	411007003-65 00675000914	1:2	IC 80 bar

Portautensili Rotanti - Estensione del programma



Unità porta creatore

Tipo 16-1	411500003-65	1:1	EC
Tipo 16-1	411500002-65 00675000927	2:1	EC
	160016161 Ø 16		
	160022161 Ø 22		
	160027161 Ø 27		
	160015161 Ø 5/8"		
	160019161 Ø 3/4"		
	160025161 Ø 1"		
	160031161 Ø 1 1/4"		
	110587		



Portautensile rotante di foratura e fresatura, per lavorazione su mandrino e contromandrino

ER 25	413002005-65 00675000907	1:1	EC
--------------	-----------------------------	-----	----



Portautensile rotante di foratura/fresatura - doppio, asse Y

ER 25	413002004-65 00675000907	1:1	EC
--------------	-----------------------------	-----	----

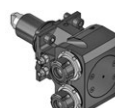

Portautensile rotante di foratura/fresatura a 2 uscite, asse Y

ER 25	413502006-65 00675000915	1:1	EC
ER 25	413502007-65 00675000915	1:1	IC 80 bar

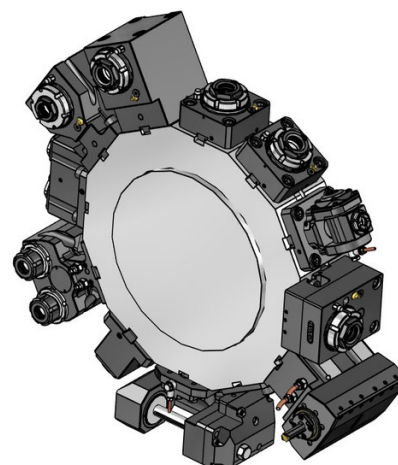
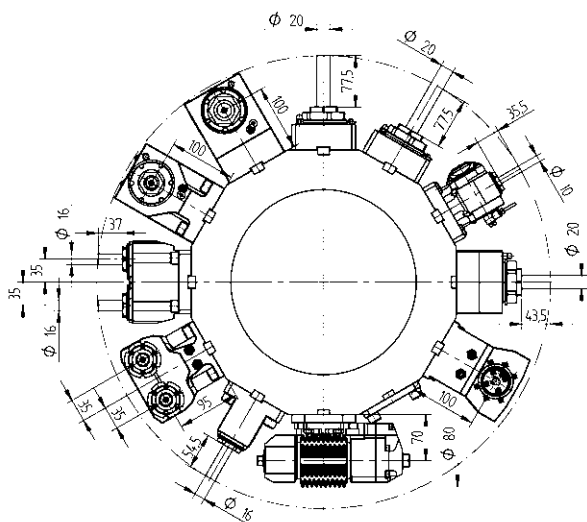

Portautensili Rotanti - Estensione del programma



Portautensile rotante di foratura/fresatura a 2 uscite, per lavorazione su mandrino e contromandrino, asse Y

ER 25 413502008-65 1:1 EC
 00675000915



Unità di brocciatura per interni ed esterni

TN765050 414532000-65 1:1 EC

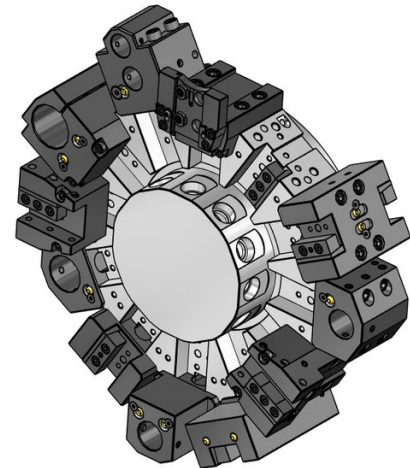
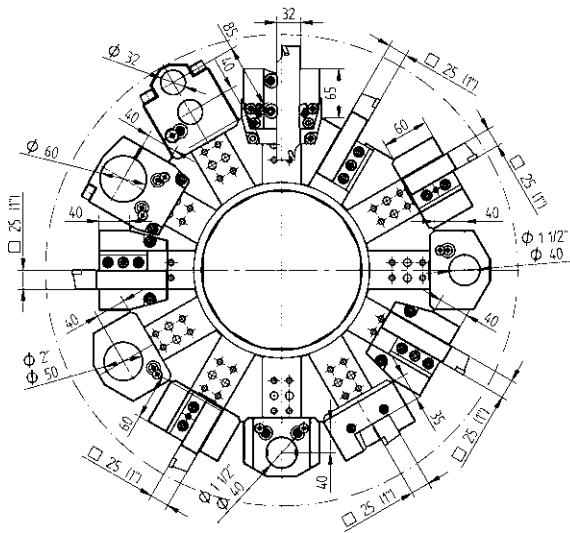

Portautensili statici - Programma standard



25(1")

Cuneo di bloccaggio

48-B27036

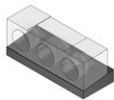

25

Piastrina di bloccaggio

48-B27037



25

Portautensile, prolungato

48-T00076



25

Portautensile per lavorazione su mandrino e contromandrino (solo per torretta con 85mm di larghezza)

48-T00158



25

Portautensile per esterni prolungato

48-T00082



25

Portautensile da taglio

48-T00156



Ø 40

Portabareno

48-T10036

Ø 50

48-T10044

Portautensili statici - Programma standard



Ø 40

Portautensile combinato

48-T13064

IC 80 bar

Ø 50

48-83292

IC 80 bar



Ø 40

Portautensile combinato prolungato

48-T10038

IC 80 bar



Ø 32

Portabareno per lavorazione su mandrino e contromandrino

48-T10086

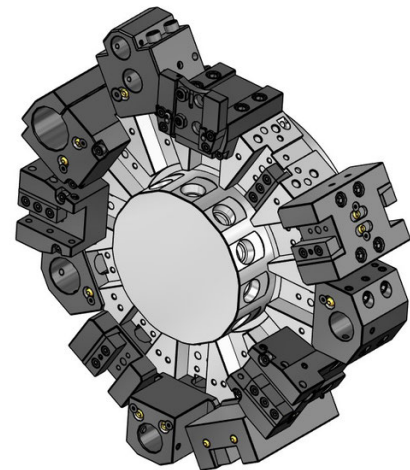
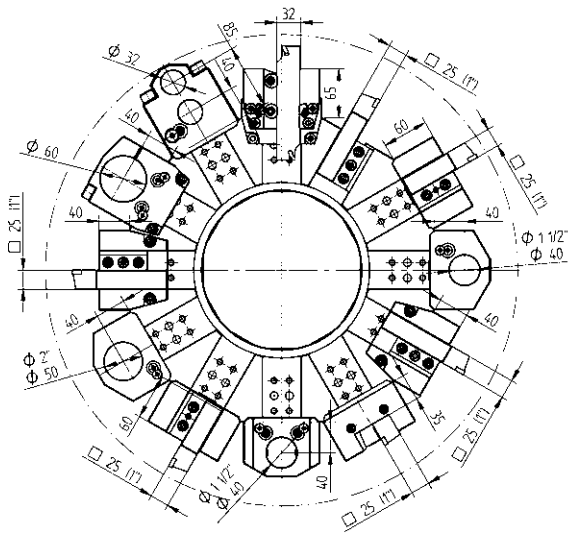

Portautensili statici - Estensione del programma

Portautensili statici - Estensione del programma



Fine corsa

48-T17002



Portautensile, prolungato, HP-IC

25 48-T00076-HP IC 80 bar



Portautensile da taglio, con regolazione

SH 32 48-104535

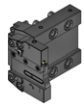

Portautensile da taglio, con regolazione, HP-IC

SH 32 48-104533R IC 80 bar
343-810100R67
SH 32 48-104533L IC 80 bar
343-810100L67



Portabareno con serraggio a morsetto

Ø 40 48-88503
Ø 50 48-88501
Ø 60 48-85667



Portabareno doppio

Ø 25 48-83452



Adattatore VDI, sinistro

VDI 30 48-83473



Adattatore VDI, destro

VDI 30 48-49950



Adattatore VDI - per lavorazione su mandrino e contromandrino

VDI 30 48-50896

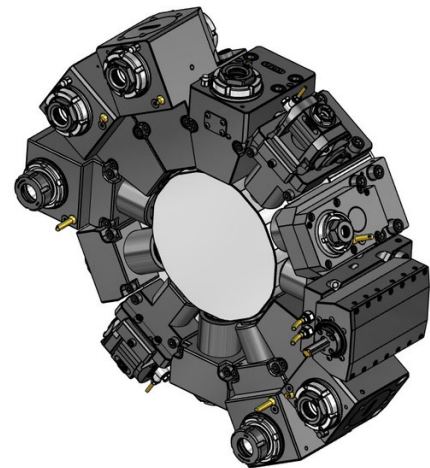
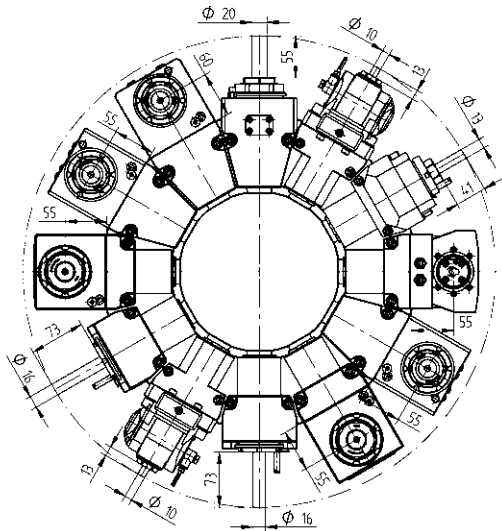

Portautensili Rotanti - Performance Series

Portautensili Rotanti - QuickFlex®



Portautensile rotante di foratura/fresatura

ER 32 410120000-00 1:1 EC
T32115, T32155, T32401
00675000780

ER 32 410120001-00 1:1 IC 30 bar
T32341
00675000780



Portautensile rotante di foratura/fresatura

ER 32 410520000-00 1:1 EC
T32114, T32154, T32400
00675000780



Portautensile rotante di foratura/fresatura

ER-32 QF 420132010-00 1:1 EC
0067732000

ER-32 QF 420132011-00 1:1 IC 80 bar
0067732000



Portautensile rotante di foratura/fresatura

ER-32 QF 420532010-00 1:1 EC
0067732000

ER-32 QF 420532011-00 1:1 IC 80 bar
0067732000



Portautensile rotante di foratura/fresatura, per lavorazione su mandrino e contromandrino

ER-32 QF 420532014-00 1:1 EC
0067732000

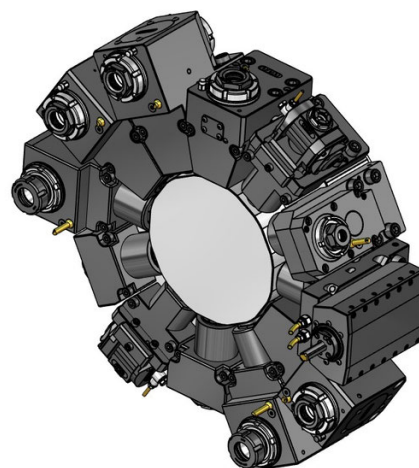
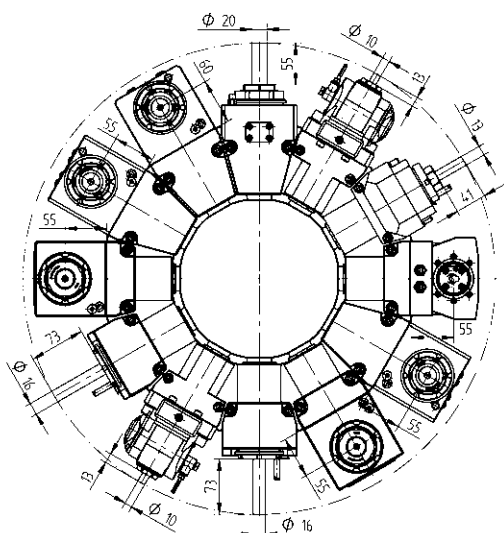

Portautensili Rotanti - Estensione del programma



Portautensile rotante di foratura/fresatura

ER 25 410116010-00 1:1 EC
 00675000831

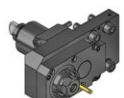

Portautensile rotante di foratura/fresatura, disassato

ER 20 410113006-00 1:2 EC
 00675000621

ER 20 410113004-00 1:2 IC 80 bar
 00675000621



Portautensile rotante di foratura/fresatura con attacco Weldon/Whistle Notch

Ø 16 410116004-00 1:1 EC



Portautensile rotante di fresatura

Ø 16 410216002-00 1:1 EC
 00675000854

Ø 22 410222000-00 1:1 EC
 00675000483

Portautensili Rotanti - Estensione del programma



Portautensile rotante di foratura/fresatura

ER-25 QF 420525010-00 1:2 EC
 0067725001

ER-25 QF 420525011-00 1:2 IC 80 bar
 0067725001

ER 32 410520017-00 2:1 EC
 00675000780



Portautensile rotante di foratura/fresatura con attacco Weldon/Whistle Notch

Ø 25 410525002-00 1:1 EC

Ø 25 410525003-00 1:1 IC 80 bar

Ø 25 410525005-00 2:1 EC



Portautensile rotante con attacco portafrese combinato DIN 6358

Ø 22 410622001-00 1:1 EC
 00675000483

Ø 27 410627003-00 1:1 EC
 00675000245

Ø 27 410627002-00 2:1 EC
 00675000245

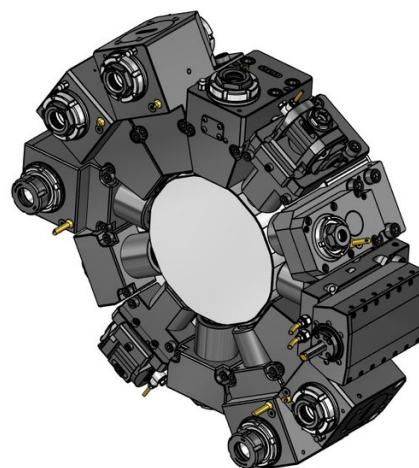
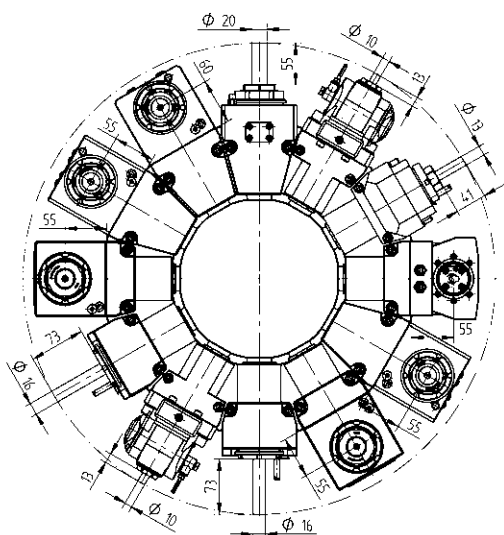

Portautensili Rotanti - Estensione del programma

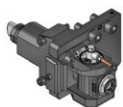

Portautensile rotante orientabile di foratura/fresatura

ER 16	411010008-00 00675000902	1:1	EC
ER 16	411010007-00 00675000902	1:1	IC 80 bar
ER 11	411007004-00 00675000914	1:2	EC
ER 11	411007005-00 00675000914	1:2	IC 80 bar

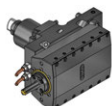

Unità di brocciatura per interni ed esterni

TN765050	414532000-00	1:1	EC
----------	--------------	-----	----

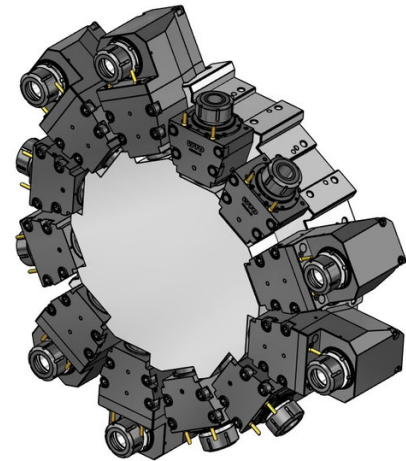
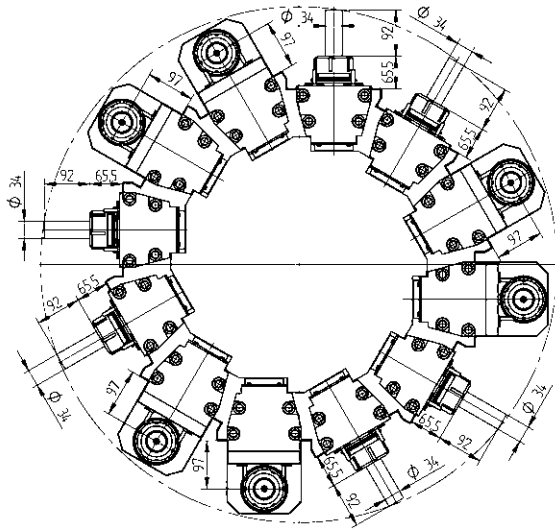

Portautensili Rotanti - Performance Series



Portautensile rotante di foratura/fresatura

- | | | | |
|--------------|--------------------------------|-----|-----------|
| ER 50 | 410134000-00
T32137, T32247 | 1:1 | EC |
| | 00675000652 | | |
| ER 50 | 410134002-00 | 1:1 | IC 80 bar |
| | 00675000652 | | |



Portautensile rotante di foratura/fresatura

- | | | | |
|--------------|--------------|-----|-----------|
| ER 50 | 410534002-00 | 1:1 | EC |
| | 00675000701 | | |
| ER 50 | 410534003-00 | 1:1 | IC 80 bar |
| | 00675000701 | | |

Portautensili Rotanti - Estensione del programma



Portautensile rotante di foratura/fresatura assiale per BT 40

- | | | | |
|------------------|--------------|-----|-----------|
| BT MAS403 | 410140000-00 | 1:1 | EC |
| BT MAS403 | 410140001-00 | 1:1 | IC 80 bar |



Portautensile rotante di foratura/fresatura assiale per ISO/CAT 40

- | | | | |
|---------------|--------------|-----|-----------|
| ISO 40 | 410140004-00 | 1:1 | EC |
| | 00675000875 | | |
| ISO 40 | 410140005-00 | 1:1 | IC 80 bar |
| | 00675000875 | | |

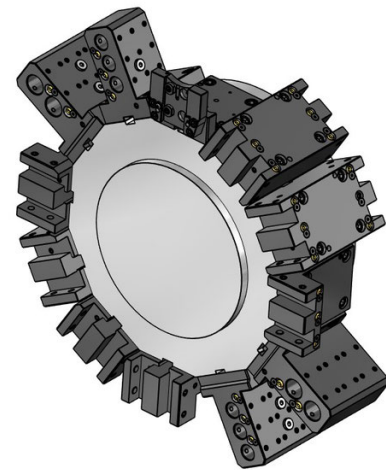
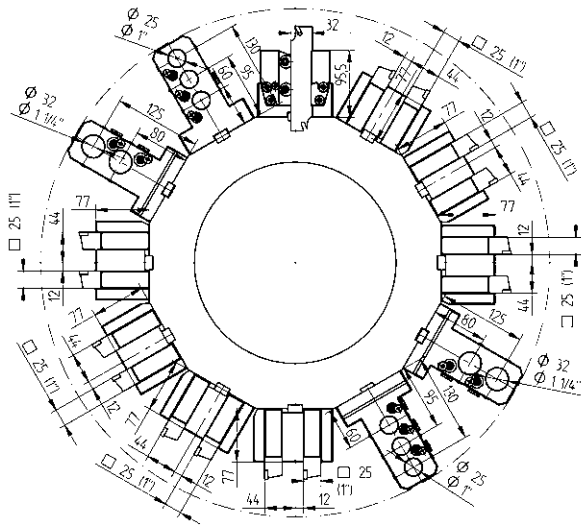

Portautensili statici - Estensione del programma



25(1")

Portautensile doppio, asse Y

48-85317



25(1")

Portautensile per lavorazione su mandrino e contromandrino, doppio, asse Y

48-85318



SH 32

Portautensile da taglio, con regolazione

48-99506



SH 32

Portautensile da taglio, con regolazione, HP-IC

48-99500R
343-810100R14

IC 80 bar

SH 32

48-99500L
343-810100L14

IC 80 bar



Ø 25

Portabareno a 3 uscite

48-85319



Ø 32

Portabareno doppio per lavorazione su mandrino e contromandrino

48-85321



Ø 25

Portabareno a 3 uscite per lavorazione su mandrino e contromandrino

48-85323

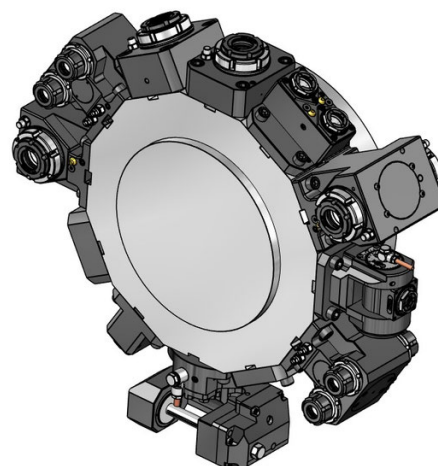
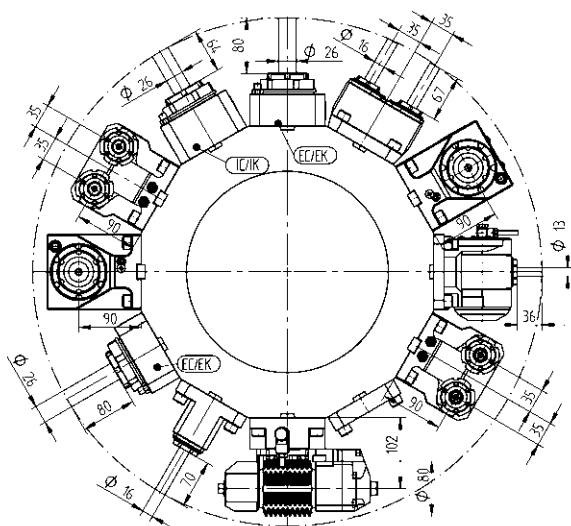

Portautensili Rotanti - QuickFlex®



Portautensile rotante di foratura/fresatura

- ER-40 QF 420140018-60 1:1 EC
0067740000
- ER-40 QF 420140019-60 1:1 IC 80 bar
0067740000



Portautensile rotante di foratura/fresatura

- ER-40 QF 420540021-60 1:1 EC
0067740000
- ER-40 QF 420540022-60 1:1 IC 80 bar
0067740000



Portautensile rotante di foratura/fresatura, per lavorazione su mandrino e contromandrino

- ER-40 QF 420540023-60 1:1 EC
0067740000

Portautensili Rotanti - Estensione del programma



Portautensile rotante di foratura/fresatura con attacco Weldon/Whistle Notch

- Ø 25 410125010-60 1:1 EC
- Ø 25 410125011-60 1:1 IC 80 bar



Portautensile rotante di fresatura con attacco combinato DIN 6358

- Ø 22 410222012-60 1:1 EC
00675000483
- Ø 27 410227010-60 1:1 EC
00675000245



Portautensile rotante di foratura/fresatura, disassato

- ER-32 QF 420132024-60 1:1 EC
0067732000
- ER-32 QF 420132025-60 1:1 IC 80 bar
0067732000
- ER-25 QF 420125012-60 1:2 EC
0067725001
- ER-25 QF 420125013-60 1:2 IC 80 bar
0067725001

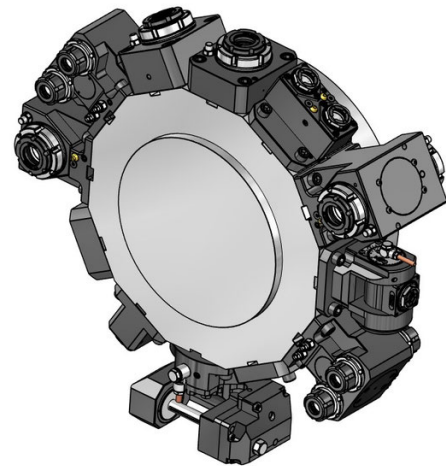
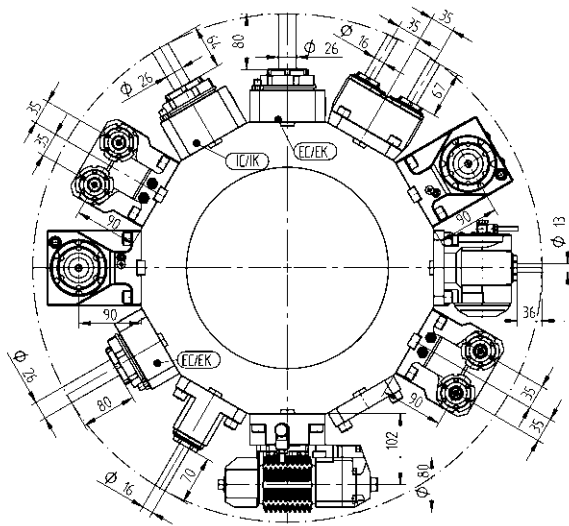

Portautensili Rotanti - Estensione del programma

Portautensili Rotanti - Estensione del programma



Portautensile rotante di foratura/fresatura

ER 25	410516010-60 00675000801	1:2	EC
ER 25	410516011-60 00675000801	1:2	IC 80 bar
ER 40	410526034-60 00675000781	2:1	EC
ER 40	410526035-60 00675000781	2:1	IC 80 bar



Portautensile rotante orientabile di foratura/fresatura

ER 20	411013013-60 00675000928	1:1	EC
ER 20	411013015-60 00675000928	1:1	IC 80 bar
ER 16	411010007-60 00675000936	1:2	EC
ER 16	411010008-60 00675000936	1:2	IC 80 bar



Portautensile rotante di foratura/fresatura con attacco Weldon/Whistle Notch

Ø 25	410525015-60	1:1	EC
Ø 25	410525016-60	1:1	IC 80 bar



Portautensile rotante portafrese a disco

Tipo 19-2	411500016-60 00675000855	3:1	EC
------------------	-----------------------------	-----	----



Portautensile rotante con attacco portafrese combinato DIN 6358

Ø 22	410622003-60 00675000483	1:1	EC
Ø 27	410627002-60 00675000245	2:1	EC

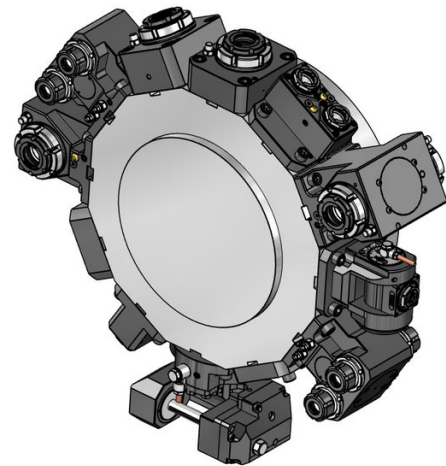
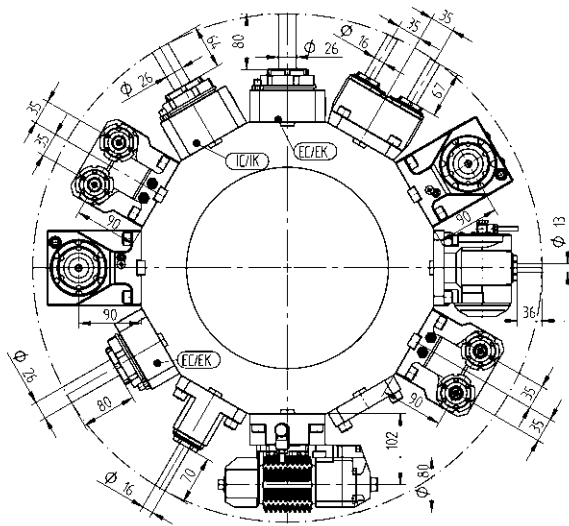

Portautensili Rotanti - Estensione del programma

Portautensili Rotanti - Estensione del programma



Unità porta creatore

Tipo 16-1 411500017-60 1:1 EC

- 00675000926
- 160016161 Ø 16
- 160022161 Ø 22
- 160027161 Ø 27
- 160015161 Ø 5/8"
- 160019161 Ø 3/4"
- 160025161 Ø 1"
- 160031161 Ø 1 1/4"
- 110587

Tipo 16-1 411500018-60 2:1 EC

- 00675000926
- 160016161 Ø 16
- 160022161 Ø 22
- 160027161 Ø 27
- 160015161 Ø 5/8"
- 160019161 Ø 3/4"
- 160025161 Ø 1"
- 160031161 Ø 1 1/4"
- 110587



Portautensile rotante di foratura e fresatura, per lavorazione su mandrino e contromandrino

ER 25 413002006-60 1:1 EC

- 00675000907



Portautensile rotante di foratura/fresatura - doppio, asse Y

ER 25 413002007-60 1:1 EC

- 00675000907



Portautensile rotante di foratura/fresatura a 2 uscite, asse Y

ER 25 413502011-60 1:1 EC

- 00675000915

ER 25 413502012-60 1:1 IC 80 bar

- 00675000915

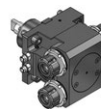

Portautensile rotante di foratura/fresatura a 2 uscite, per lavorazione su mandrino e contromandrino, asse Y

ER 25 413502013-60 1:1 EC

- 00675000915

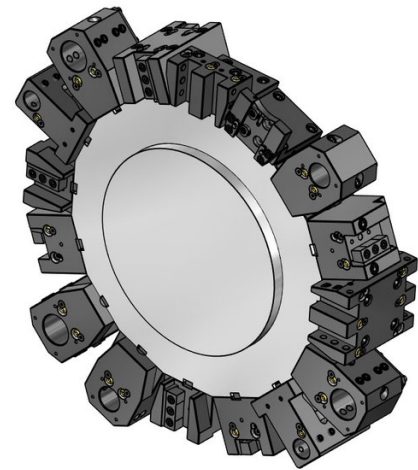
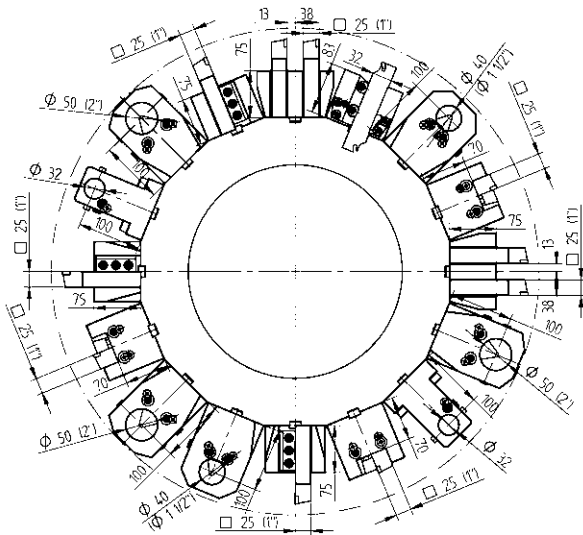

Portautensili statici - Programma standard

Portautensili statici - Programma standard



Portautensile

25 48-92428



Portautensile, HP-IC

25 48-92428-HP IC 80 bar



Portautensile per lavorazione su mandrino e contromandrino

25 48-92438



Portautensile per lavorazione su mandrino e contromandrino, HP-IC

25 48-92438-HP IC 80 bar



Portautensile per esterni

25 48-86719



Portautensile per esterni, HP-IC

25 48-109249-HP IC 80 bar



Portautensile combinato, LF=100

Ø 40 48-92397 IC 80 bar

 241140020 ER32

 241140026 ER40

Ø 50 48-92467 IC 80 bar

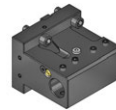

Portabareno per lavorazione su mandrino e contromandrino

Ø 32 48-101033



Coperchio di protezione

48-87089

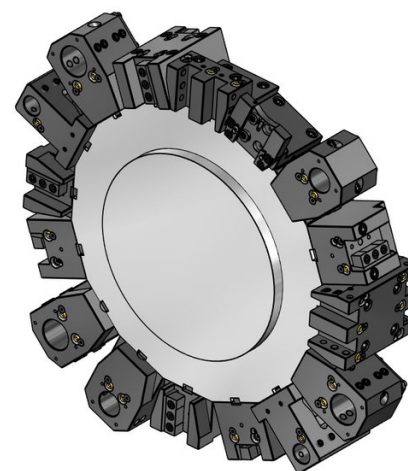
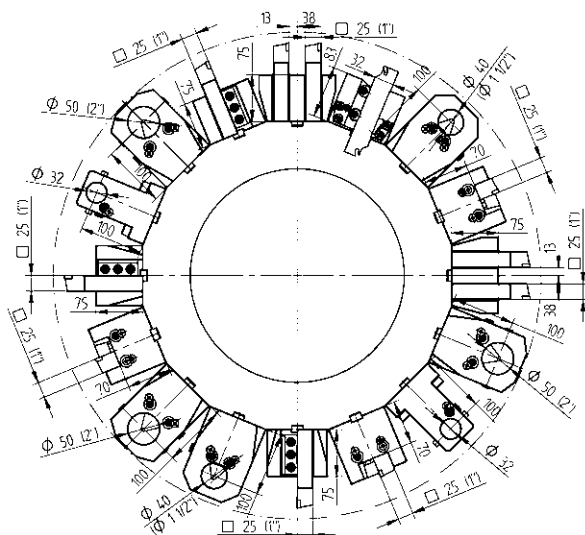

Portautensili statici - Estensione del programma



25(1")

Portautensile doppio, asse Y

48-86103



25(1")

Portautensile per lavorazione su mandrino e contromandrino, doppio, asse Y

48-86150



SH 32

Portautensile da taglio, con regolazione

48-99060



SH 32

Portautensile da taglio, con regolazione, HP-IC

SH 32 48-102256R

IC 80 bar

SH 32 48-102256L

IC 80 bar

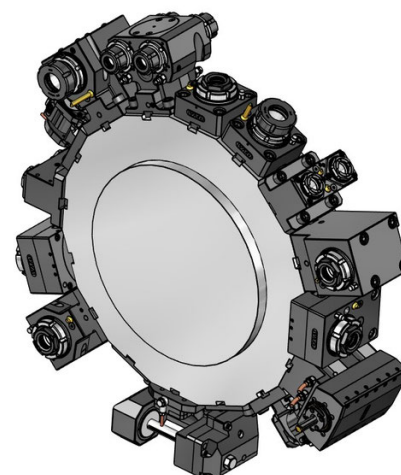
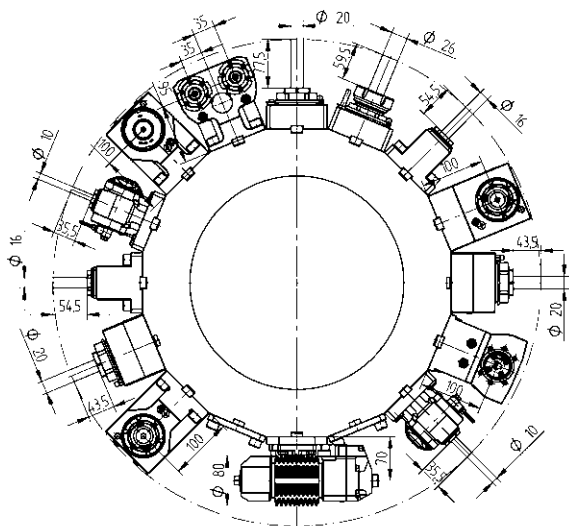

Portautensili Rotanti - QuickFlex®



Portautensile rotante di foratura/fresatura

ER-32 QF 420132015-65 1:1 EC

0067732000

ER-32 QF 420132016-65 1:1 IC 80 bar

0067732000



Portautensile rotante di foratura/fresatura, LF=100

ER-32 QF 420532018-65 1:1 EC

0067732000

ER-32 QF 420532019-65 1:1 IC 80 bar

0067732000



Portautensile rotante radiale, per lavorazione su mandrino e contromandrino, LF=100

ER-32 QF 420532020-65 1:1 EC

0067732000

Portautensili Rotanti - Estensione del programma



Portautensile rotante di foratura/fresatura

ER 40 410126001-65 1:1 EC

00675000079



Portautensile rotante di fresatura con attacco combinato DIN 6358

Ø 22 410222002-65 1:1 EC

00675000483



Portautensile rotante di foratura/fresatura, disassato

ER-32 QF 420132037-65 1:1 EC

0067732000

ER-32 QF 420132038-65 1:1 IC 80 bar

0067732000

ER-25 QF 420125010-65 1:2 EC

0067725001

ER-25 QF 420125011-65 1:2 IC 80 bar

0067725001



Portautensile rotante di foratura/fresatura, LF=100

ER 40 410526007-65 1:1 EC

00675000079

ER 40 410526008-65 1:1 IC 80 bar

00675000079

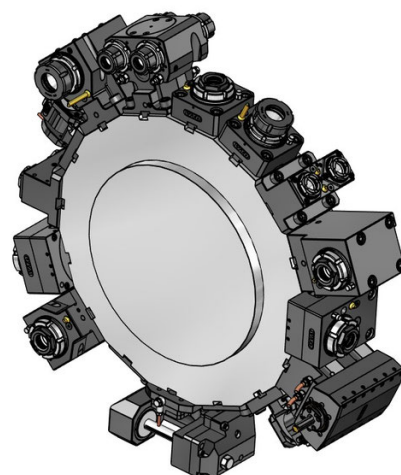
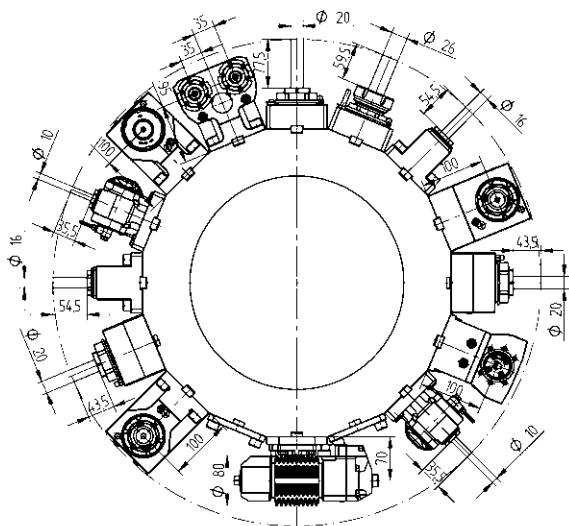

Portautensili Rotanti - Estensione del programma



Portautensile rotante di foratura/fresatura, LF=100

ER-25 QF	420525012-65 0067725001	1:2	EC
ER-25 QF	420525013-65 0067725001	1:2	IC 80 bar
ER-32 QF	420532029-65 0067732000	2:1	EC
ER-32 QF	420532030-65 0067732000	2:1	IC 80 bar



Portautensile rotante radiale portafrese combinato DIN6358, LF=100

Ø 22	410622002-65 00675000483	1:1	EC
-------------	-----------------------------	-----	----



Portautensile rotante orientabile di foratura/fresatura

ER 16	411010002-65 00675000902	1:1	EC
ER 16	411010003-65 00675000902	1:1	IC 80 bar
ER 11	411007002-65 00675000914	1:2	EC
ER 11	411007003-65 00675000914	1:2	IC 80 bar

Portautensili Rotanti - Estensione del programma



Unità porta creatore

Tipo 16-1	411500003-65	1:1	EC
Tipo 16-1	411500002-65	2:1	EC
	00675000927		
	160016161 Ø 16		
	160022161 Ø 22		
	160027161 Ø 27		
	160015161 Ø 5/8"		
	160019161 Ø 3/4"		
	160025161 Ø 1"		
	160031161 Ø 1 1/4"		
	110587		



Portautensile rotante di foratura e fresatura, per lavorazione su mandrino e contromandrino

ER 25	413002005-65 00675000907	1:1	EC
--------------	-----------------------------	-----	----

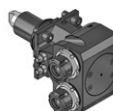

Portautensile rotante di foratura/fresatura a 2 uscite, asse Y

ER 25	413502006-65 00675000915	1:1	EC
ER 25	413502007-65 00675000915	1:1	IC 80 bar

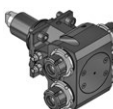

Portautensile rotante di foratura/fresatura a 2 uscite, per lavorazione su mandrino e contromandrino, asse Y

ER 25	413502008-65 00675000915	1:1	EC
--------------	-----------------------------	-----	----

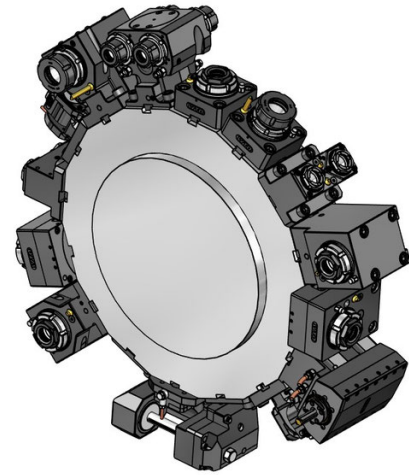
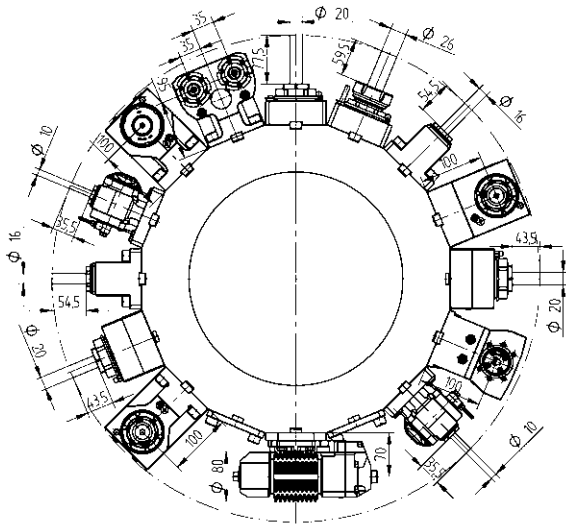

Portautensili Rotanti - Estensione del programma



Unità di brocciatura per interni ed esterni

TN765050 414532000-65

1:1 EC

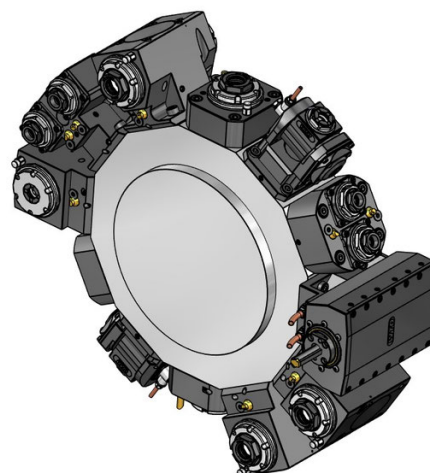
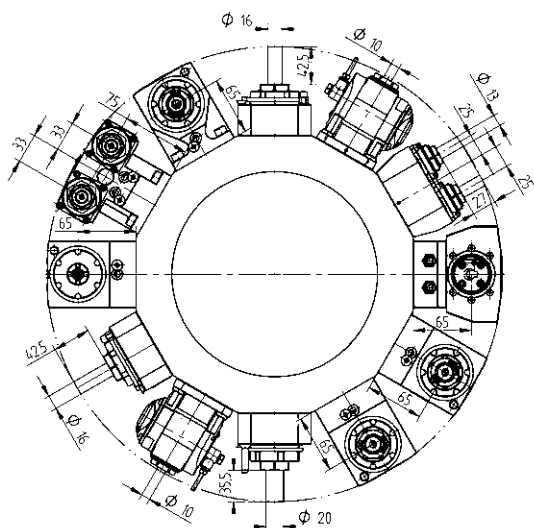

Portautensili Rotanti - QuickFlex®



Portautensile rotante di foratura/fresatura

- ER-25 QF** 420125010-45 1:1 EC
 0067725000
- ER-25 QF** 420125011-45 1:1 IC 80 bar
 0067725000



Portautensile rotante di foratura/fresatura

- ER-25 QF** 420525010-45 1:1 EC
 0067725000
- ER-25 QF** 420525011-45 1:1 IC 80 bar
 0067725000

Portautensili Rotanti - Estensione del programma



Portautensile rotante di foratura/fresatura

- ER 32** 410120002-45 1:1 EC
 0067525000
- ER 32** 410120003-45 1:1 IC 80 bar
 0067525000



Portautensile rotante di foratura/fresatura, disassato

- ER 25** 410116006-45 1:1 EC
 00675000932
- ER 25** 410116007-45 1:1 IC 80 bar
 00675000932
- ER 20** 410113002-45 1:2 EC
 00675000939
- ER 20** 410113003-45 1:2 IC 80 bar
 00675000939
- ER 16** 410110000-45 1:3 EC
 00675000937
- ER 16** 410110001-45 1:3 IC 80 bar
 00675000937
- ER 25** 410116008-45 1,5:1 EC
 00675000932
- ER 25** 410116009-45 1,5:1 IC 80 bar
 00675000932

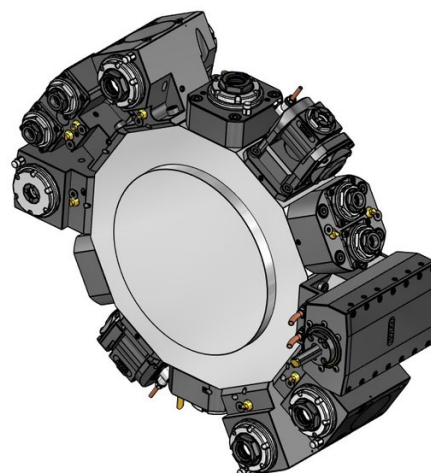
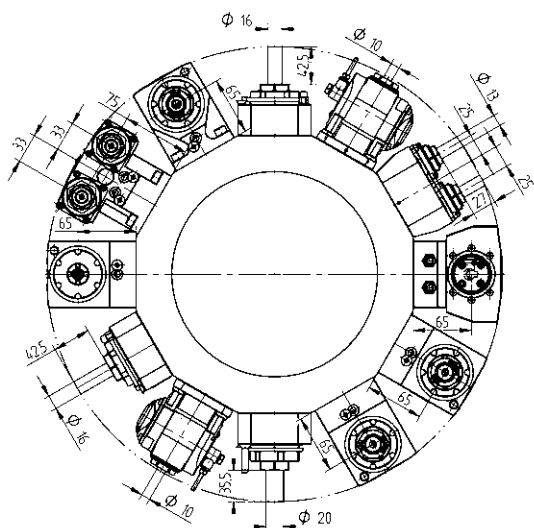

Portautensili Rotanti - Estensione del programma



Portautensile rotante di foratura/fresatura

ER 32	410520010-45 0067725000	1:1	EC
ER 32	410520007-45 0067725000	1:1	IC 80 bar
ER-20 QF	420520010-45 0067720001	1:2	EC
ER-20 QF	420520011-45 0067720001	1:2	IC 80 bar
ER 16	410810002-45 00675000841	1:3	EC
ER 16	410810003-45 00675000841	1:3	IC 80 bar
ER-25 QF	420525013-45 0067725000	2:1	EC
ER-25 QF	420525014-45 0067725000	2:1	IC 80 bar
ER 32	410520008-45 00675000827	2:1	EC
ER 32	410520009-45 00675000827	2:1	IC 80 bar



Portautensile rotante orientabile di foratura/fresatura

ER 16	411010000-45 00675000902	1:1	EC
ER 16	411010001-45 00675000902	1:1	IC 80 bar
ER 11	411007000-45 00675000914	1:2	EC
ER 11	411007001-45 00675000914	1:2	IC 80 bar

Portautensili Rotanti - Estensione del programma



Portautensile rotante portafrese a disco

Tipo 14-2	411500001-45 00675000489	2,73:1	EC
	160016142 Ø 16		
	160022142 Ø 22		
	160027142 Ø 27		
	160015142 Ø 5/8"		
	160019142 Ø 3/4"		
	160023142 Ø 7/8"		
	160025142 Ø 1"		



Unità porta creatore

Tipo 15-2	410900002-45 00675001015	1:1	EC
	160008152 Ø 8		
	160010152 Ø 10		
	160013152 Ø 13		
	160016152 Ø 16		
	160022152 Ø 22		
	160015152 Ø 5/8"		
	160019152 Ø 3/4"		
	110587		



Portautensile rotante di foratura/fresatura - doppio, asse Y

ER 20	413002007-45 00675001016	1:1	EC
--------------	-----------------------------	-----	----

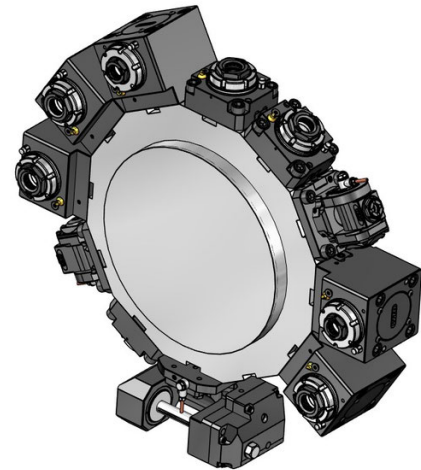
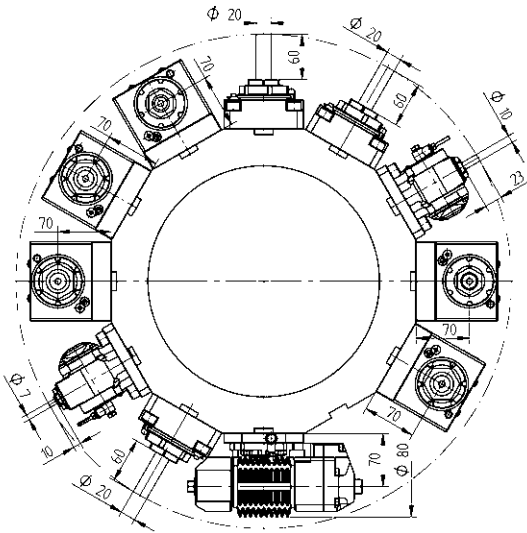

Portautensili Rotanti - QuickFlex®



Portautensile rotante di foratura/fresatura

- | | | | |
|-----------------|--------------------------|-----|-----------|
| ER-32 QF | 420132010-63
CB-4782B | 1:1 | EC |
| | 0067732000 | | |
| ER-32 QF | 420132011-63
CB-4782A | 1:1 | IC 80 bar |
| | 0067732000 | | |



Portautensile rotante di foratura/fresatura

- | | | | |
|-----------------|--------------------------|-----|-----------|
| ER-32 QF | 420532010-63
CB-4783B | 1:1 | EC |
| | 0067732000 | | |
| ER-32 QF | 420532011-63
CB-4783A | 1:1 | IC 80 bar |
| | 0067732000 | | |

Portautensili Rotanti - Estensione del programma



Portautensile rotante di fresatura con attacco combinato DIN 6358

- | | | | |
|-------------|--------------|-----|----|
| Ø 27 | 410227001-63 | 1:1 | EC |
| | 00675000245 | | |



Portautensile rotante di foratura/fresatura

- | | | | |
|-----------------|--------------|-----|-----------|
| ER-25 QF | 420525010-63 | 1:2 | EC |
| | 0067725001 | | |
| ER-25 QF | 420525011-63 | 1:2 | IC 80 bar |
| | 0067725001 | | |



Portautensile rotante radiale portafrese combinato DIN6358

- | | | | |
|-------------|--------------|-----|----|
| Ø 22 | 410622001-63 | 2:1 | EC |
| | 00675000483 | | |
| Ø 27 | 410627002-63 | 2:1 | EC |
| | 00675000245 | | |



Portautensile rotante orientabile di foratura/fresatura

- | | | | |
|--------------|--------------|-----|-----------|
| ER 16 | 411010000-63 | 1:1 | EC |
| | 00675000902 | | |
| ER 16 | 411010001-63 | 1:1 | IC 80 bar |
| | 00675000902 | | |
| ER 11 | 411007000-63 | 1:2 | EC |
| | 00675000914 | | |
| ER 11 | 411007001-63 | 1:2 | IC 80 bar |
| | 00675000914 | | |

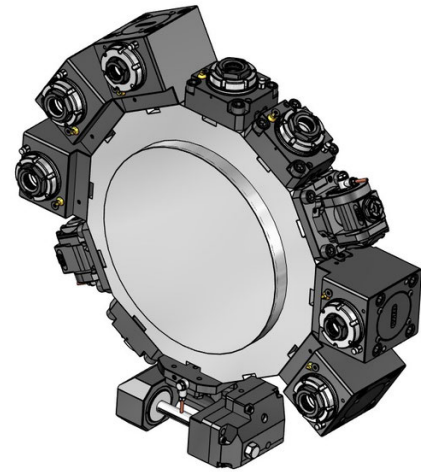
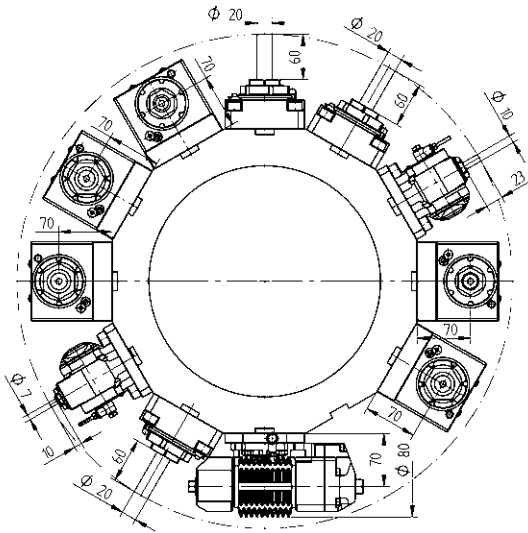

Portautensili Rotanti - Estensione del programma



Unità porta creatore

Tipo 16-1 411500000-63 1:1 EC

- 00675000926
- 160016161 Ø 16
- 160022161 Ø 22
- 160027161 Ø 27
- 160015161 Ø 5/8"
- 160019161 Ø 3/4"
- 160025161 Ø 1"
- 160031161 Ø 1 1/4"

Tipo 16-1 411500001-63 2:1 EC

- 00675000927
- 160016161 Ø 16
- 160022161 Ø 22
- 160027161 Ø 27
- 160015161 Ø 5/8"
- 160019161 Ø 3/4"
- 160025161 Ø 1"
- 160031161 Ø 1 1/4"

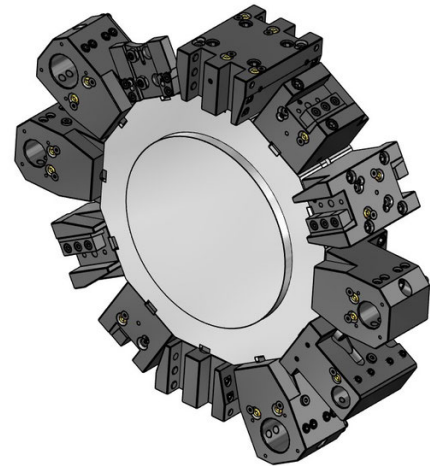
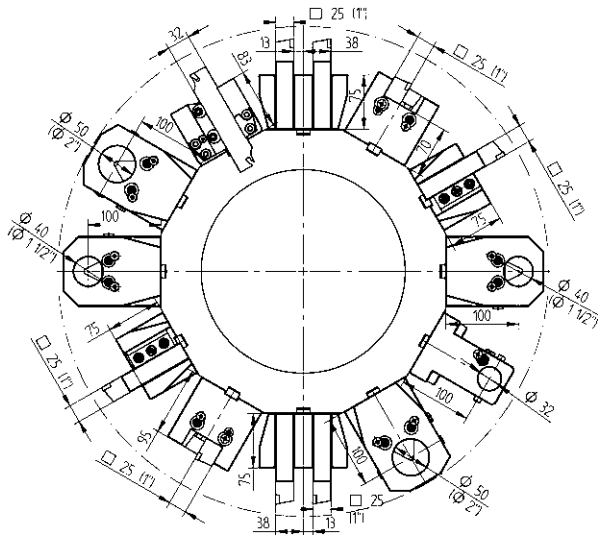

Portautensili statici - Programma standard

Portautensili statici - Programma standard



Portautensile

25 48-92428



Portautensile, HP-IC

25 48-92428-HP IC 80 bar



Portautensile per lavorazione su mandrino e contromandrino

25 48-92438



Portautensile per lavorazione su mandrino e contromandrino, HP-IC

25 48-92438-HP IC 80 bar



Portautensile per esterni

25 48-86719



Portautensile per esterni, HP-IC

25 48-109249-HP IC 80 bar



Portautensile combinato, LF=100

Ø 40 48-92397 IC 80 bar

 241140020 ER32

 241140026 ER40

Ø 50 48-92467 IC 80 bar



Portabareno per lavorazione su mandrino e contromandrino

Ø 32 48-101033



Coperchio di protezione

48-87089

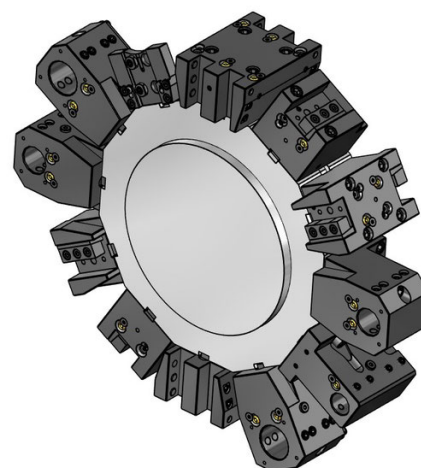
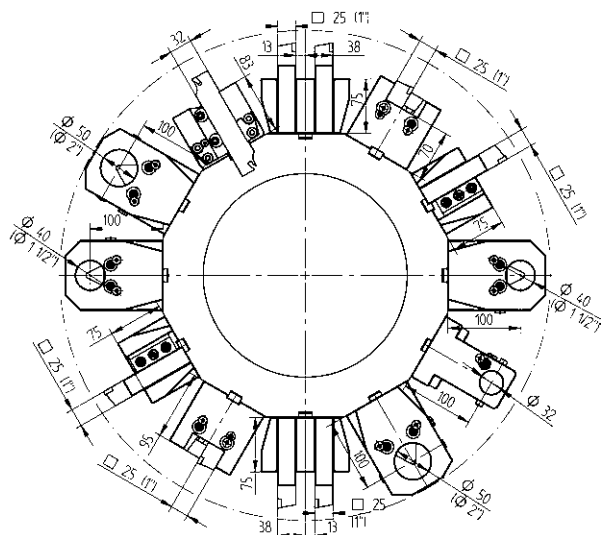

Portautensili statici - Estensione del programma



25(1")

Portautensile doppio, asse Y

48-86103



25(1")

Portautensile per lavorazione su mandrino e contromandrino, doppio, asse Y

48-86150



SH 32

Portautensile da taglio, con regolazione

48-99060



SH 32

Portautensile da taglio, con regolazione, HP-IC

48-102256R

IC 80 bar

SH 32 48-102256L

IC 80 bar

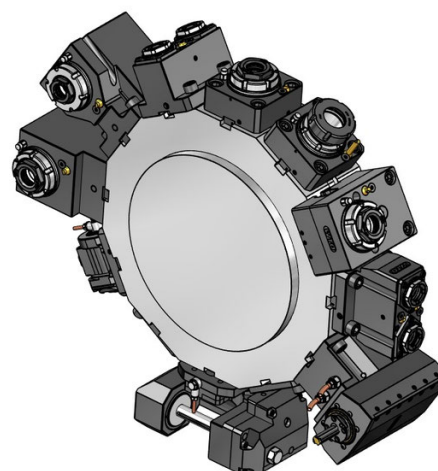
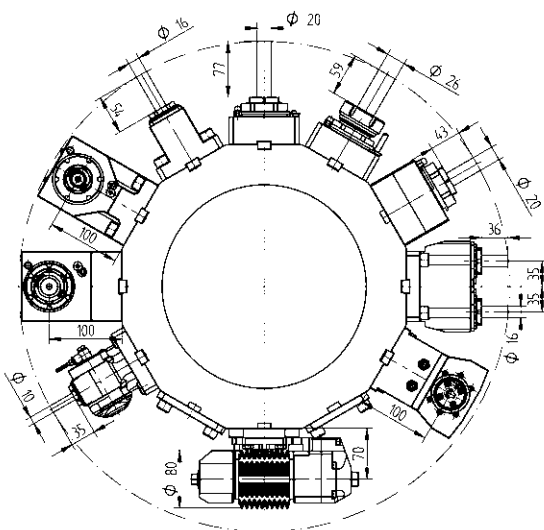

Portautensili Rotanti - QuickFlex®



Portautensile rotante di foratura/fresatura

ER-32 QF 420132015-65 1:1 EC
 0067732000

ER-32 QF 420132016-65 1:1 IC 80 bar
 0067732000



Portautensile rotante di foratura/fresatura, LF=100

ER-32 QF 420532018-65 1:1 EC
 0067732000

ER-32 QF 420532019-65 1:1 IC 80 bar
 0067732000



Portautensile rotante radiale, per lavorazione su mandrino e contromandrino, LF=100

ER-32 QF 420532020-65 1:1 EC
 0067732000

Portautensili Rotanti - Estensione del programma

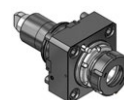

Portautensile rotante di foratura/fresatura

ER 40 410126001-65 1:1 EC
 00675000079



Portautensile rotante di fresatura con attacco combinato DIN 6358

Ø 22 410222002-65 1:1 EC
 00675000483



Portautensile rotante di foratura/fresatura, disassato

ER-32 QF 420132037-65 1:1 EC
 0067732000

ER-32 QF 420132038-65 1:1 IC 80 bar
 0067732000

ER-25 QF 420125010-65 1:2 EC
 0067725001

ER-25 QF 420125011-65 1:2 IC 80 bar
 0067725001



Portautensile rotante di foratura/fresatura, LF=100

ER 40 410526007-65 1:1 EC
 00675000079

ER 40 410526008-65 1:1 IC 80 bar
 00675000079

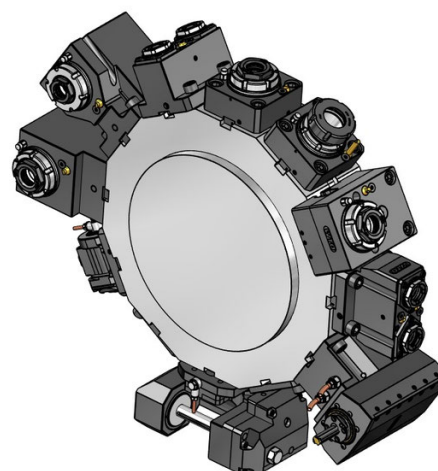
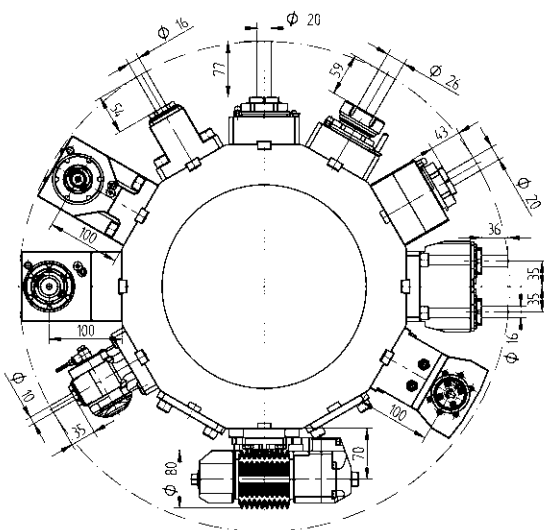

Portautensili Rotanti - Estensione del programma



Portautensile rotante di foratura/fresatura, LF=100

ER-25 QF	420525012-65	1:2	EC
	0067725001		
ER-25 QF	420525013-65	1:2	IC 80 bar
	0067725001		
ER-32 QF	420532029-65	2:1	EC
	0067732000		
ER-32 QF	420532030-65	2:1	IC 80 bar
	0067732000		



Portautensile rotante radiale portafrese combinato DIN6358, LF=100

Ø 22	410622002-65	1:1	EC
	00675000483		



Portautensile rotante orientabile di foratura/fresatura

ER 16	411010002-65	1:1	EC
	00675000902		
ER 16	411010003-65	1:1	IC 80 bar
	00675000902		
ER 11	411007002-65	1:2	EC
	00675000914		
ER 11	411007003-65	1:2	IC 80 bar
	00675000914		

Portautensili Rotanti - Estensione del programma



Unità porta creatore

Tipo 16-1	411500003-65	1:1	EC
Tipo 16-1	411500002-65	2:1	EC
	00675000927		
	160016161 Ø 16		
	160022161 Ø 22		
	160027161 Ø 27		
	160015161 Ø 5/8"		
	160019161 Ø 3/4"		
	160025161 Ø 1"		
	160031161 Ø 1 1/4"		
	110587		



Portautensile rotante di foratura e fresatura, per lavorazione su mandrino e contromandrino

ER 25	413002005-65	1:1	EC
	00675000907		



Portautensile rotante di foratura/fresatura - doppio, asse Y

ER 25	413002004-65	1:1	EC
	00675000907		



Unità di brocciatura per interni ed esterni

TN765050	414532000-65	1:1	EC
-----------------	--------------	-----	----

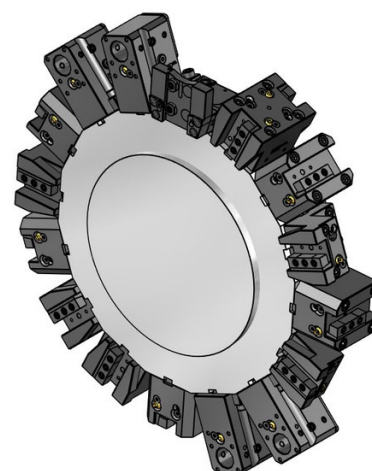
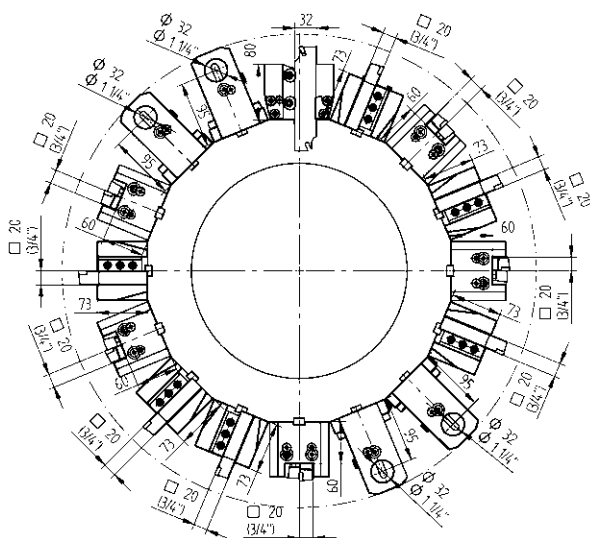

Portautensili statici - Programma standard

Portautensili statici - Estensione del programma



Portautensile
20 48-92036



SH 32 Portautensile da taglio, con regolazione
48-103287



Portautensile, HP-IC
20 48-92036-HP IC 80 bar



SH 32 Portautensile da taglio, con regolazione, HP-IC
48-110160R IC 80 bar
SH 32 48-110160L IC 80 bar



Portautensile per lavorazione su mandrino e contromandrino
20 48-92038



Portautensile per lavorazione su mandrino e contromandrino, HP-IC
20 48-92038-HP IC 80 bar



Portautensile per esterni
20 48-92045



Portautensile per esterni, HP-IC
20 48-92045-HP IC 80 bar



Portautensile combinato, universale, LF=95
Ø 32 48-109277 IC 80 bar

 241132020 ER32

 241132016 ER25

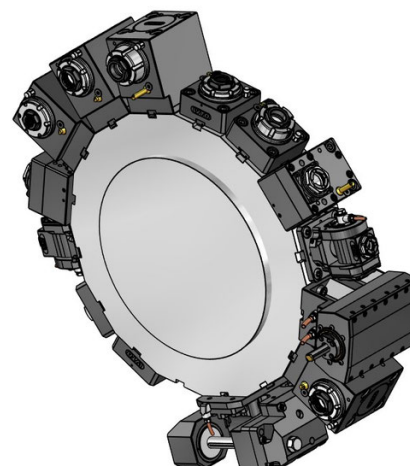
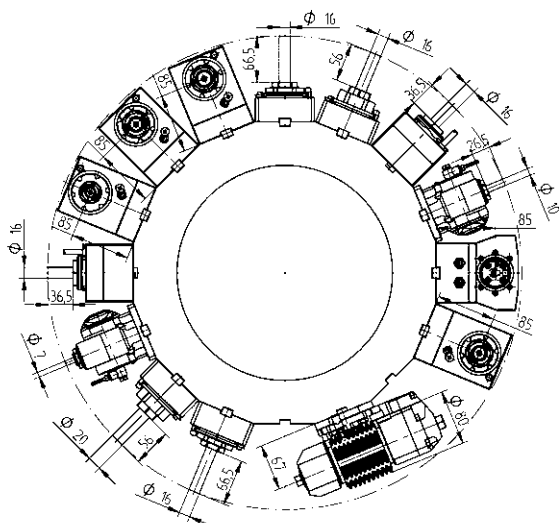

Portautensili Rotanti - QuickFlex®



Portautensile rotante di foratura/fresatura

- | | | | |
|-----------------|--------------|-----|-----------|
| ER-25 QF | 420125015-55 | 1:1 | EC |
| | 0067725000 | | |
| ER-25 QF | 420125016-55 | 1:1 | IC 80 bar |
| | 0067725000 | | |



Portautensile rotante di foratura/fresatura, LF=85

- | | | | |
|-----------------|--------------|-----|-----------|
| ER-25 QF | 420525018-55 | 1:1 | EC |
| | 0067725000 | | |
| ER-25 QF | 420525019-55 | 1:1 | IC 80 bar |
| | 0067725000 | | |



Portautensile rotante radiale, per lavorazione su mandrino e contromandrino, LF=85

- | | | | |
|-----------------|--------------|-----|----|
| ER-25 QF | 420525020-55 | 1:1 | EC |
| | 0067725000 | | |

Portautensili Rotanti - Estensione del programma



Portautensile rotante di foratura/fresatura

- | | | | |
|--------------|--------------|-----|-----------|
| ER 32 | 410120010-55 | 1:1 | EC |
| | 0067725000 | | |
| ER 32 | 410120011-55 | 1:1 | IC 80 bar |
| | 0067725000 | | |



Portautensile rotante di fresatura con attacco combinato DIN 6358

- | | | | |
|-------------|--------------|-----|----|
| Ø 22 | 410222004-55 | 1:1 | EC |
| | 00675000483 | | |



Portautensile rotante di foratura/fresatura, disassato

- | | | | |
|--------------|--------------|-----|-----------|
| ER 25 | 410116029-55 | 1:1 | EC |
| | 00675000932 | | |
| ER 25 | 410116030-55 | 1:1 | IC 80 bar |
| | 00675000932 | | |
| ER 20 | 410113009-55 | 1:2 | EC |
| | 00675000939 | | |
| ER 20 | 410113010-55 | 1:2 | IC 80 bar |
| | 00675000939 | | |
| ER 16 | 410410004-55 | 1:3 | EC |
| | 00675000937 | | |
| ER 16 | 410410005-55 | 1:3 | IC 80 bar |
| | 00675000937 | | |

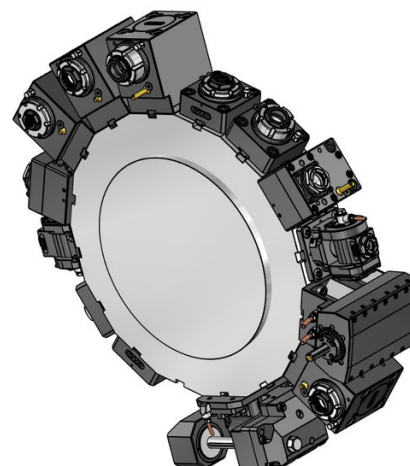
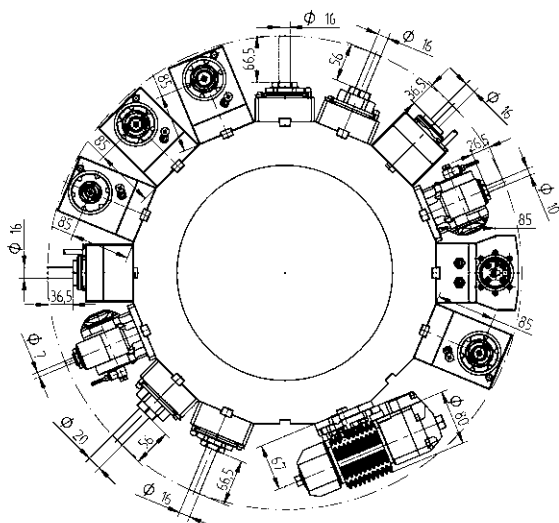

Portautensili Rotanti - Estensione del programma



Portautensile rotante di foratura/fresatura, LF=85

ER 32	410520030-55 0067725000	1:1	EC
ER 32	410520031-55 0067725000	1:1	IC 80 bar
ER-20 QF	420520014-55 0067720001	1:2	EC
ER-20 QF	420520015-55 0067720001	1:2	IC 80 bar
ER 16	410810020-55 00675000841	1:3	EC
ER 16	410810021-55 00675000841	1:3	IC 80 bar
ER-25 QF	420525032-55 0067725000	2:1	EC
ER-25 QF	420525033-55 0067725000	2:1	IC 80 bar



Portautensile rotante radiale portafrese combinato DIN6358, LF=85

Ø 22	410622011-55 00675000483	1:1	EC
-------------	-----------------------------	-----	----

Portautensili Rotanti - Estensione del programma



Portautensile rotante orientabile di foratura/fresatura

ER 16	411010005-55 00675000902	1:1	EC
ER 16	411010006-55 00675000902	1:1	IC 80 bar
ER 11	411007007-55 00675000914	1:2	EC
ER 11	411007008-55 00675000914	1:2	IC 80 bar



Unità porta creatore

Tipo 16-1	411500002-55	1:1	EC
Tipo 16-1	411500001-55 00675000927	2:1	EC
	160016161 Ø 16		
	160022161 Ø 22		
	160027161 Ø 27		
	160015161 Ø 5/8"		
	160019161 Ø 3/4"		
	160025161 Ø 1"		
	160031161 Ø 1 1/4"		
	110587		

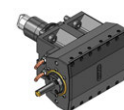

Unità di brocciatura per interni ed esterni

TN765050	414532000-55	1:1	EC
-----------------	--------------	-----	----

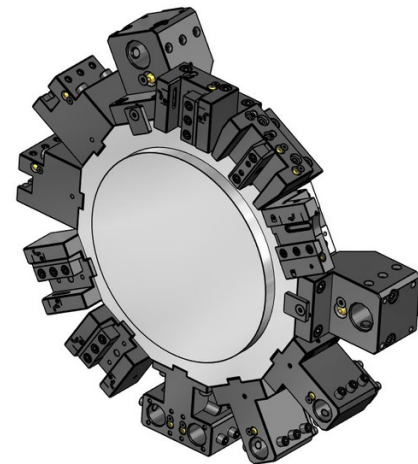
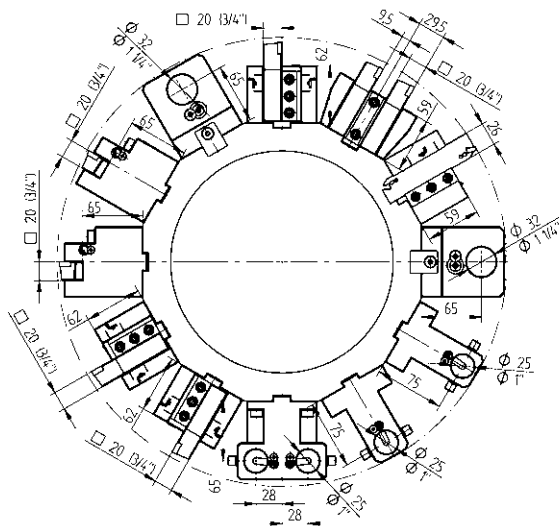

Portautensili statici - Programma standard

Portautensili statici - Estensione del programma



Portautensile
20 48-101470



Portautensile, HP-IC
20 48-101470-HP IC 80 bar



Portautensile per lavorazione su mandrino e contromandrino
20 48-101471



Portautensile per esterni
20 48-102352



Portautensile combinato, LF=75
Ø 25 48-101472



Portautensile combinato
Ø 32 48-107155



Portautensile doppio, asse Y
20 48-101473



Portautensile da taglio
SH 26 48-100419



Portautensile da taglio, HP-IC
SH 26 48-102274R IC 80 bar
SH 26 48-102274L IC 80 bar
SH 32 48-112233R IC 80 bar
343-810100R95
SH 32 48-112233L IC 80 bar
343-810100L95



Portautensile combinato doppio, asse Y
Ø 25 48-101474

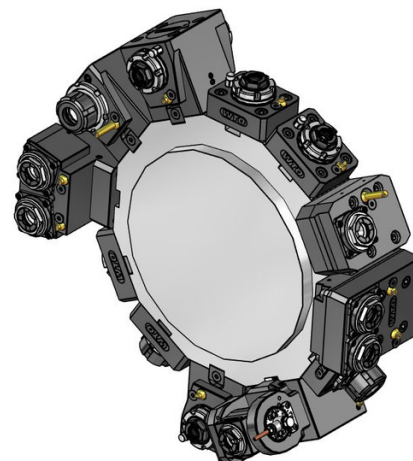
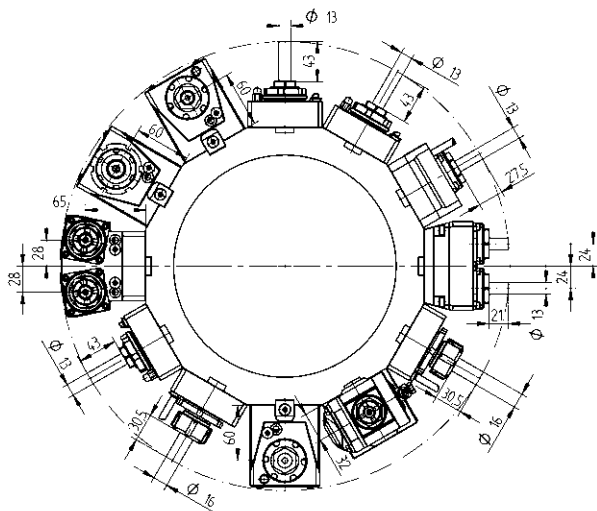

Portautensili Rotanti - QuickFlex®



Portautensile rotante di foratura/fresatura

- ER-20 QF 420120010-44 1:1 EC
0067720000
- ER-20 QF 420120011-44 1:1 IC 80 bar
0067720000



Portautensile rotante di foratura/fresatura, LF=60

- ER-20 QF 420520010-44 1:1 EC
0067720000
- ER-20 QF 420520011-44 1:1 IC 80 bar
0067720000



Portautensile rotante radiale, per lavorazione su mandrino e contromandrino, LF=60

- ER-20 QF 420520012-44 1:1 EC
0067720000

Portautensili Rotanti - Estensione del programma



Portautensile rotante di foratura/fresatura

- ER 25 410116004-44 1:1 EC
00675000720
- ER 25 410116002-44 1:1 IC 80 bar
00675000720

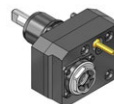

Portautensile rotante di foratura/fresatura, disassato

- ER 20 410113004-44 1:2 EC
00675000939
- ER 16 410110002-44 1:3 EC
00675000937
- ER 25 410116005-44 1,5:1 EC
00675000932

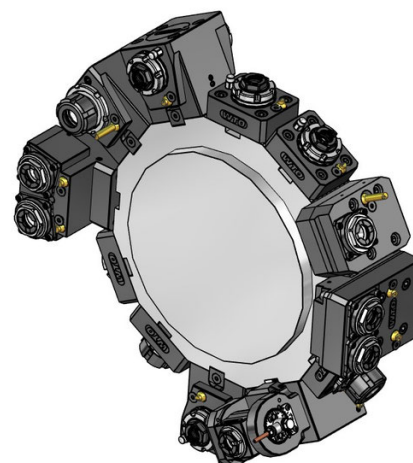
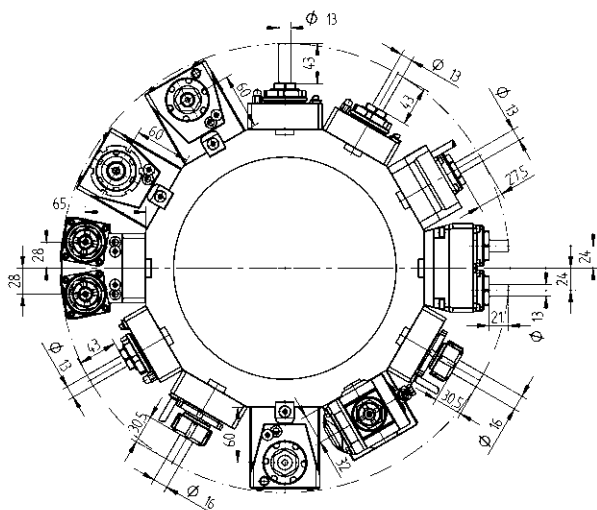

Portautensili Rotanti - Estensione del programma



Portautensile rotante di foratura/fresatura, LF=60

ER 25	410516005-44 00675000720	1:1	EC
ER 25	410516006-44 00675000720	1:1	IC 80 bar
ER 20	410513002-44 00675000833	1:2	EC
ER 20	410513003-44 00675000833	1:2	IC 80 bar
ER 16	410810006-44 00675000841	1:3	EC
ER 16	410810007-44 00675000841	1:3	IC 80 bar
ER 25	410516002-44 00675000720	2:1	EC
ER 25	410516003-44 00675000720	2:1	IC 80 bar



Portautensile rotante radiale portafrese combinato DIN6358, LF=60

Ø 22	410622000-44 00675000483	1:1	EC
Ø 22	410622001-44 00675000483	2:1	EC

Portautensili Rotanti - Estensione del programma



Portautensile rotante orientabile di foratura/fresatura, LF=32

ER 16	411010004-44 00675000902	1:1	EC
ER 16	411010005-44 00675000902	1:1	IC 80 bar
ER 11	411007006-44 00675000914	1:2	EC
ER 11	411007007-44 00675000914	1:2	IC 80 bar



Portautensile rotante di foratura/fresatura - doppio, asse Y

ER 20	413002003-44 00675000939	1:1	EC
ER 20	413002004-44 00675000939	1:1	IC 80 bar



Portautensile rotante di foratura/fresatura a 2 uscite, asse Y

ER 20	413502004-44 00675000939	1:1	EC
ER 20	413502005-44 00675000939	1:1	IC 80 bar

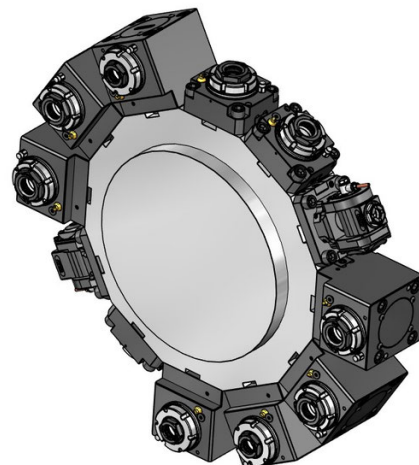
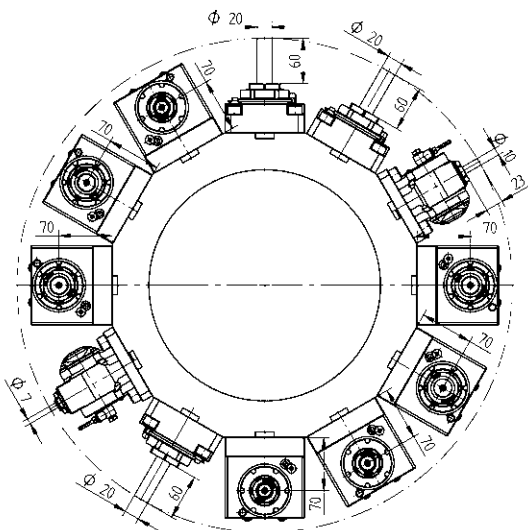

Portautensili Rotanti - QuickFlex®



Portautensile rotante di foratura/fresatura

- | | | | |
|-----------------|--------------------------|-----|-----------|
| ER-32 QF | 420132010-63
CB-4782B | 1:1 | EC |
| | 0067732000 | | |
| ER-32 QF | 420132011-63
CB-4782A | 1:1 | IC 80 bar |
| | 0067732000 | | |



Portautensile rotante di foratura/fresatura

- | | | | |
|-----------------|--------------------------|-----|-----------|
| ER-32 QF | 420532010-63
CB-4783B | 1:1 | EC |
| | 0067732000 | | |
| ER-32 QF | 420532011-63
CB-4783A | 1:1 | IC 80 bar |
| | 0067732000 | | |

Portautensili Rotanti - Estensione del programma



Portautensile rotante di fresatura con attacco combinato DIN 6358

- | | | | |
|-------------|--------------|-----|----|
| Ø 27 | 410227001-63 | 1:1 | EC |
| | 00675000245 | | |



Portautensile rotante di foratura/fresatura

- | | | | |
|-----------------|--------------|-----|-----------|
| ER-25 QF | 420525010-63 | 1:2 | EC |
| | 0067725001 | | |
| ER-25 QF | 420525011-63 | 1:2 | IC 80 bar |
| | 0067725001 | | |



Portautensile rotante radiale portafrese combinato DIN6358

- | | | | |
|-------------|--------------|-----|----|
| Ø 22 | 410622001-63 | 2:1 | EC |
| | 00675000483 | | |
| Ø 27 | 410627002-63 | 2:1 | EC |
| | 00675000245 | | |



Portautensile rotante orientabile di foratura/fresatura

- | | | | |
|--------------|--------------|-----|-----------|
| ER 16 | 411010000-63 | 1:1 | EC |
| | 00675000902 | | |
| ER 16 | 411010001-63 | 1:1 | IC 80 bar |
| | 00675000902 | | |
| ER 11 | 411007000-63 | 1:2 | EC |
| | 00675000914 | | |
| ER 11 | 411007001-63 | 1:2 | IC 80 bar |
| | 00675000914 | | |

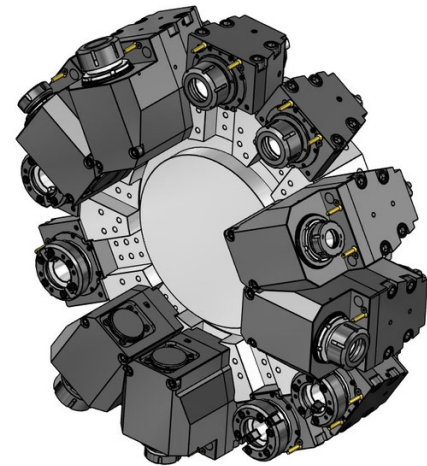
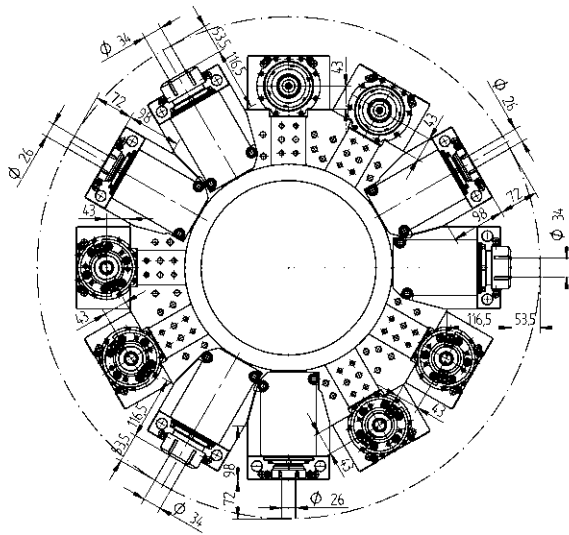

Portautensili Rotanti - Performance Series



- Portautensile rotante di foratura/fresatura**
- | | | | |
|--------------|--------------------------------|-----|-----------|
| ER 50 | 410134000-00
T32137, T32247 | 1:1 | EC |
| | 00675000652 | | |
| ER 50 | 410134002-00 | 1:1 | IC 80 bar |
| | 00675000652 | | |



- Portautensile rotante di foratura/fresatura**
- | | | | |
|--------------|--------------|-----|-----------|
| ER 40 | 410526004-00 | 1:1 | EC |
| | 00675000781 | | |
| ER 40 | 410526005-00 | 1:1 | IC 80 bar |
| | 00675000781 | | |



- Portautensile rotante di foratura/fresatura**
- | | | | |
|--------------|--------------|-----|-----------|
| ER 50 | 410534002-00 | 1:1 | EC |
| | 00675000701 | | |
| ER 50 | 410534003-00 | 1:1 | IC 80 bar |
| | 00675000701 | | |

Portautensili Rotanti - Estensione del programma



- Portautensile rotante di foratura/fresatura assiale per BT 40**
- | | | | |
|------------------|--------------|-----|-----------|
| BT MAS403 | 410140000-00 | 1:1 | EC |
| BT MAS403 | 410140001-00 | 1:1 | IC 80 bar |



- Portautensile rotante di foratura/fresatura assiale per ISO/CAT 40**
- | | | | |
|---------------|--------------|-----|-----------|
| ISO 40 | 410140004-00 | 1:1 | EC |
| | 00675000875 | | |
| ISO 40 | 410140005-00 | 1:1 | IC 80 bar |
| | 00675000875 | | |

Bussole cilindriche standard di riduzione



Bussola di riduzione Ø 25

240025006	Ø 6
240025008	Ø 8
240025010	Ø 10
240025012	Ø 12
240025014	Ø 14
240025016	Ø 16
240025020	Ø 20



Bussola di riduzione Ø 32

240032006	Ø 6
240032008	Ø 8
240032010	Ø 10
240032012	Ø 12
240032014	Ø 14
240032016	Ø 16
240032018	Ø 18
240032020	Ø 20
240032025	Ø 25



Bussola di riduzione Ø 40

240040006	Ø 6
240040008	Ø 8
240040010	Ø 10
240040012	Ø 12
240040014	Ø 14
240040016	Ø 16
240040020	Ø 20
240040025	Ø 25
240040032	Ø 32



Bussola di riduzione Ø 50

240050010	Ø 10
240050012	Ø 12
240050016	Ø 16
240050020	Ø 20
240050025	Ø 25
240050032	Ø 32
240050040	Ø 40

Bussole cilindriche standard di riduzione con cava



Bussola di riduzione Ø 40

240140010	Ø 10
240140012	Ø 12
240140015	Ø 15
240140016	Ø 16
240140020	Ø 20
240140025	Ø 25
240140032	Ø 32



Bussola di riduzione Ø 50

240150020	Ø 20
240150025	Ø 25
240150032	Ø 32
240150040	Ø 40



Bussola di riduzione Ø 60

240160032	Ø 32
240160040	Ø 40
240160050	Ø 50

Bussole di riduzione standard cono Morse

Bussole di riduzione cilindriche portabareni

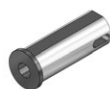

Bussola di riduzione Ø 32

240532001	MT 1
240532002	MT 2
240532003	MT 3

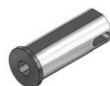

Bussola di riduzione Ø 40

240540001	MT 1
240540002	MT 2
240540003	MT 3
240540004	MT 4



Bussola di riduzione Ø 50

240550002	MT 2
240550003	MT 3
240550004	MT 4



Bussola di riduzione Ø 25

24-T20180	ø 8
24-T20182	ø 10
24-T20184	ø 12
24-T20186	ø 16
24-T20188	ø 20



Bussola di riduzione Ø 32

24-T20112	ø 8
24-T20114	ø 10
24-T20116	ø 12
24-T20118	ø 16
24-T20120	ø 20
24-T20122	ø 25



Bussola di riduzione Ø 40

24-T20086	ø 8
24-T20088	ø 10
24-T20090	ø 12
24-T20092	ø 16
24-T20094	ø 20
24-T20096	ø 25
24-T20098	ø 32



Bussola di riduzione Ø 50

24-T20160	ø 10
24-T20162	ø 12
24-T20164	ø 16
24-T20166	ø 20
24-T20168	ø 25
24-T20170	ø 32
24-T20172	ø 40

Bussole di riduzione prolungate cilindriche portabareni prolungate



Bussola di riduzione Ø 32

24-T20124	Ø 8
24-T20126	Ø 10
24-T20128	Ø 12
24-T20130	Ø 16



Bussola di riduzione Ø 40

24-T20106	Ø 8
24-T20108	Ø 10
24-T20110	Ø 12
24-T20194	Ø 16
24-T20196	Ø 20
24-T20216	Ø 25

Bussole di riduzione con Morse portabareni



Bussola di riduzione Ø 40

24-T22046	MT 2
24-T22042	MT 3

Pinze DIN 6499B (ER/ESX)

Pinze DIN 6499B (ER/ESX)



ER 11

190011000	∅ 7-0.5	∅ 0.276-0.020
190011010	∅ 1-0.5	∅ 0.039-0.020
190011015	∅ 1.5-1	∅ 0.059-0.039
190011020	∅ 2-1.5	∅ 0.079-0.059
190011025	∅ 2.5-2	∅ 0.098-0.079
190011030	∅ 3-2.5	∅ 0.118-0.098
190011035	∅ 3.5-3	∅ 0.138-0.118
190011040	∅ 4-3.5	∅ 0.158-0.138
190011045	∅ 4.5-4	∅ 0.177-0.158
190011050	∅ 5-4.5	∅ 0.197-0.177
190011055	∅ 5.5-5	∅ 0.217-0.197
190011060	∅ 6-5.5	∅ 0.236-0.217
190011065	∅ 6.5-6	∅ 0.256-0.236
190011070	∅ 7-6.5	∅ 0.276-0.256



ER 25

190025000	∅ 16-1	∅ 0.630-0.039
190025010	∅ 1-0.5	∅ 0.039-0.020
190025020	∅ 2-1	∅ 0.079-0.039
190025030	∅ 3-2	∅ 0.118-0.079
190025040	∅ 4-3	∅ 0.157-0.118
190025050	∅ 5-4	∅ 0.197-0.157
190025060	∅ 6-5	∅ 0.236-0.197
190025070	∅ 7-6	∅ 0.276-0.236
190025080	∅ 8-7	∅ 0.315-0.276
190025090	∅ 9-8	∅ 0.354-0.315
190025100	∅ 10-9	∅ 0.394-0.354
190025110	∅ 11-10	∅ 0.433-0.394
190025120	∅ 12-11	∅ 0.472-0.433
190025130	∅ 13-12	∅ 0.512-0.472
190025140	∅ 14-13	∅ 0.551-0.512
190025150	∅ 15-14	∅ 0.591-0.551
190025160	∅ 16-15	∅ 0.630-0.591



ER 16

190016000	∅ 10-0.5	∅ 0.394-0.020
190016010	∅ 1-0.5	∅ 0.039-0.020
190016020	∅ 2-1	∅ 0.079-0.039
190016030	∅ 3-2	∅ 0.118-0.079
190016040	∅ 4-3	∅ 0.158-0.118
190016050	∅ 5-4	∅ 0.197-0.158
190016060	∅ 6-5	∅ 0.236-0.197
190016070	∅ 7-6	∅ 0.276-0.236
190016080	∅ 8-7	∅ 0.315-0.276
190016090	∅ 9-8	∅ 0.354-0.315
190016100	∅ 10-9	∅ 0.394-0.354



ER 32

190032000	∅ 20-2	∅ 0.787-0.079
190032020	∅ 2-1	∅ 0.079-0.039
190032030	∅ 3-2	∅ 0.118-0.079
190032040	∅ 4-3	∅ 0.157-0.118
190032050	∅ 5-4	∅ 0.197-0.157
190032060	∅ 6-5	∅ 0.236-0.197
190032070	∅ 7-6	∅ 0.276-0.236
190032080	∅ 8-7	∅ 0.315-0.276
190032090	∅ 9-8	∅ 0.354-0.315
190032100	∅ 10-9	∅ 0.394-0.354
190032110	∅ 11-10	∅ 0.433-0.394
190032120	∅ 12-11	∅ 0.472-0.433
190032130	∅ 13-12	∅ 0.512-0.472
190032140	∅ 14-13	∅ 0.551-0.512
190032150	∅ 15-14	∅ 0.591-0.551
190032160	∅ 16-15	∅ 0.630-0.591
190032170	∅ 17-16	∅ 0.669-0.630
190032180	∅ 18-17	∅ 0.709-0.669
190032190	∅ 19-18	∅ 0.748-0.709
190032200	∅ 20-19	∅ 0.787-0.748



ER 20

190020000	∅ 13-1	∅ 0.512-0.039
190020010	∅ 1-0.5	∅ 0.039-0.020
190020020	∅ 2-1	∅ 0.079-0.039
190020030	∅ 3-2	∅ 0.118-0.079
190020040	∅ 4-3	∅ 0.157-0.118
190020050	∅ 5-4	∅ 0.197-0.157
190020060	∅ 6-5	∅ 0.236-0.197
190020070	∅ 7-6	∅ 0.276-0.236
190020080	∅ 8-7	∅ 0.315-0.276
190020090	∅ 9-8	∅ 0.354-0.315
190020100	∅ 10-9	∅ 0.394-0.354
190020110	∅ 11-10	∅ 0.433-0.394
190020120	∅ 12-11	∅ 0.472-0.433
190020130	∅ 13-12	∅ 0.512-0.472

Pinze DIN 6499B (ER/ESX)



ER 40

190040000	ø 26-3	ø 1.024-0.118
190040030	ø 3-2	ø 0.118-0.079
190040040	ø 4-3	ø 0.157-0.118
190040050	ø 5-4	ø 0.197-0.157
190040060	ø 6-5	ø 0.236-0.197
190040070	ø 7-6	ø 0.276-0.236
190040080	ø 8-7	ø 0.315-0.276
190040090	ø 9-8	ø 0.354-0.315
190040100	ø 10-9	ø 0.394-0.354
190040110	ø 11-10	ø 0.433-0.394
190040120	ø 12-11	ø 0.472-0.433
190040130	ø 13-12	ø 0.512-0.472
190040140	ø 14-13	ø 0.551-0.512
190040150	ø 15-14	ø 0.591-0.551
190040160	ø 16-15	ø 0.630-0.591
190040170	ø 17-16	ø 0.669-0.630
190040180	ø 18-17	ø 0.709-0.669
190040190	ø 19-18	ø 0.748-0.709
190040200	ø 20-19	ø 0.787-0.748
190040210	ø 21-20	ø 0.827-0.787
190040220	ø 22-21	ø 0.866-0.827
190040230	ø 23-22	ø 0.906-0.866
190040240	ø 24-23	ø 0.945-0.906
190040250	ø 25-24	ø 0.984-0.945
190040260	ø 26-25	ø 1.024-0.984



ER 50

190050000	ø 34-10	ø 1.339-0.394
190050060	ø 6-4	ø 0.236-0.157
190050080	ø 8-6	ø 0.315-0.236
190050100	ø 10-8	ø 0.394-0.315
190050120	ø 12-10	ø 0.472-0.394
190050140	ø 14-12	ø 0.551-0.472
190050160	ø 16-14	ø 0.630-0.551
190050180	ø 18-16	ø 0.709-0.630
190050200	ø 20-18	ø 0.787-0.709
190050220	ø 22-20	ø 0.866-0.787
190050240	ø 24-22	ø 0.945-0.866
190050260	ø 26-24	ø 1.024-0.945
190050280	ø 28-26	ø 1.102-1.024
190050300	ø 30-28	ø 1.181-1.102
190050320	ø 32-30	ø 1.260-1.181
190050340	ø 32-30	ø 1.260-1.181

Pinze DIN 6499B (ER/ESX) - vulcanizzate per refrigerante



ER 11

191011030	ø 3	
191011040	ø 4	
191011050	ø 5	
191011060	ø 6	
191111013-in		ø 0.125
191111019-in		ø 0.188
191111025-in		ø 0.25



ER 16

191016000	ø 3-10	
191016030	ø 3	
191016040	ø 4	
191016050	ø 5	
191016060	ø 6	
191016070	ø 7	
191016080	ø 8	
191016090	ø 9	
191016100	ø 10	
191116001		ø 0.125-0.375
191116013-in		ø 0.125
191116019-in		ø 0.188
191116025-in		ø 0.25
191116031-in		ø 0.313
191116038-in		ø 0.375



ER 20

191020000	ø 3-12	
191020030	ø 3	
191020040	ø 4	
191020050	ø 5	
191020060	ø 6	
191020070	ø 7	
191020080	ø 8	
191020090	ø 9	
191020100	ø 10	
191020110	ø 11	
191020120	ø 12	
191120001		ø 0.125-0.5
191120013-in		ø 0.125
191120019-in		ø 0.188
191120025-in		ø 0.25
191120031-in		ø 0.313
191120038-in		ø 0.375
191120044-in		ø 0.438
191120050-in		ø 0.5

Pinze DIN 6499B (ER/ESX) - vulcanizzate per refrigerante

Pinze DIN 6499B (ER/ESX) - vulcanizzate per refrigerante



ER 25

191025000	ø 4-16	
191025030	ø 3	
191025040	ø 4	
191025050	ø 5	
191025060	ø 6	
191025070	ø 7	
191025080	ø 8	
191025090	ø 9	
191025100	ø 10	
191025110	ø 11	
191025120	ø 12	
191025130	ø 13	
191025140	ø 14	
191025150	ø 15	
191025160	ø 16	
191125001		ø 0.25-0.625
191125025-in		ø 0.25
191125031-in		ø 0.313
191125038-in		ø 0.375
191125044-in		ø 0.438
191125050-in		ø 0.5
191125056-in		ø 0.563
191125063-in		ø 0.625



ER 40

191040060	ø 6	
191040080	ø 8	
191040100	ø 10	
191040120	ø 12	
191040140	ø 14	
191040160	ø 16	
191040180	ø 18	
191040200	ø 20	
191040220	ø 22	
191040250	ø 25	
191140025-in		ø 0.25
191140031-in		ø 0.313
191140038-in		ø 0.375
191140044-in		ø 0.438
191140050-in		ø 0.5
191140056-in		ø 0.563
191140063-in		ø 0.625
191140069-in		ø 0.688
191140075-in		ø 0.75
191140088-in		ø 0.875
191140100-in		ø 1



ER 32

191032000	ø 4-20	
191032030	ø 3	
191032040	ø 4	
191032050	ø 5	
191032060	ø 6	
191032070	ø 7	
191032080	ø 8	
191032090	ø 9	
191032100	ø 10	
191032110	ø 11	
191032120	ø 12	
191032130	ø 13	
191032140	ø 14	
191032150	ø 15	
191032160	ø 16	
191032170	ø 17	
191032180	ø 18	
191032190	ø 19	
191032200	ø 20	
191132001		ø 0.25-0.75
191132025-in		ø 0.25
191132031-in		ø 0.313
191132038-in		ø 0.375
191132044-in		ø 0.438
191132050-in		ø 0.5
191132056-in		ø 0.563
191132063-in		ø 0.625
191132069-in		ø 0.688
191132075-in		ø 0.75



Qualità senza compromessi.

Tutte le fasi di lavorazione sono eseguite alla perfezione.

Dalla fase di progettazione fino alla fine della produzione non facciamo compromessi in termini di qualità.

I nostri prodotti sono costantemente controllati con macchine di misura 3D durante tutte le fasi del ciclo di produzione.

WTO nel mondo

WTO

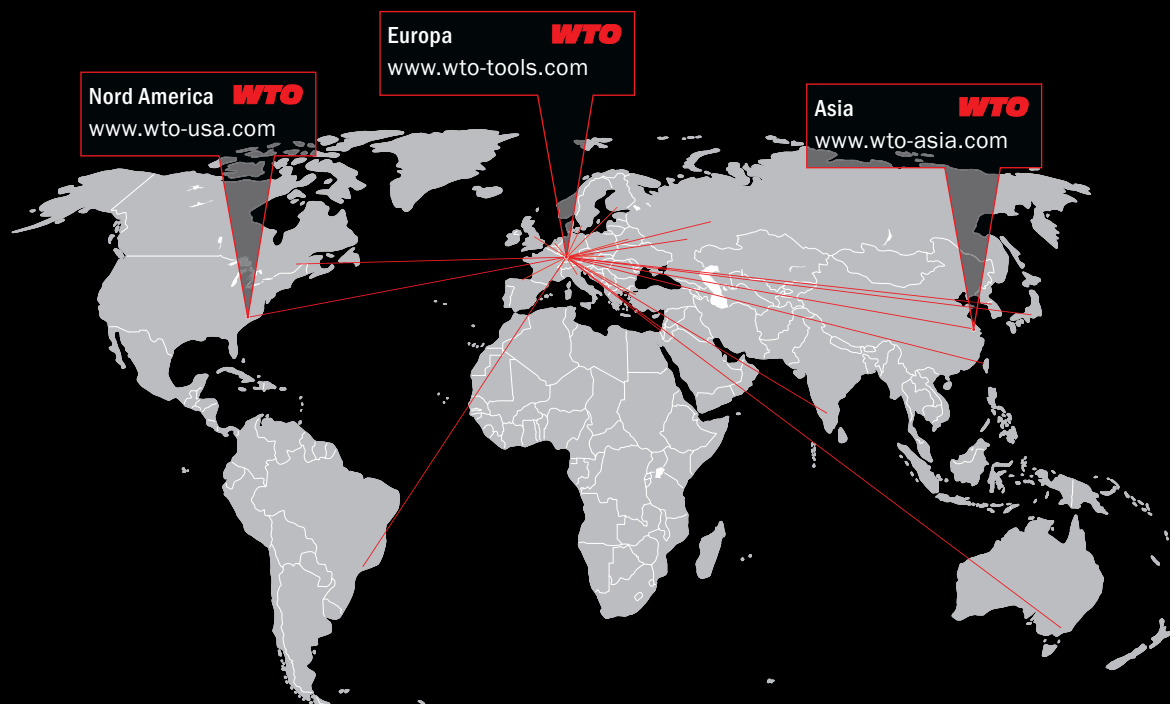

WTO
Werkzeug-
Einrichtungen GmbH
Neuer Hohdammweg 1
77797 Ohlsbach
Germania

WTO Inc.
13900-F South Lakes Dr.
Charlotte, NC 28273
Stati Uniti d'America

WTO Asia
WTO Precision Tool Holders
(Shanghai) Co. Ltd.
Room 109-110, Building 2
No. 228 Banting Road
Jiuting Town,
Songjiang District
201615 Shanghai
Cina

Our distribution partners. Competence right there.

Australia
Dimac Tooling Ltd.
sales@dimac.com.au

Finland
Suomen Terästuonti Oy
myynti@stt.as

Korea
WTO Office Korea
is.chon@wto-korea.com

Spain
ITALMATIC, S.A.
italmatic@italmatic.es

Belarus
LLC „PMI Engineering“
tool@pmi.by

France
Alexandre Mathelin
alm@wto.de

Messico
Workholding Engineering De México
info@wem.com.mx

Sweden
Bonthron & Ewing AB
info@bonthron-ewing.se

Brazil
TF2
tfdois@tfdois.com.br

Great Britain
Cutwel Ltd.
sales@cutwel.net

Netherlands
Toologic BeNeLux B.V.
info@toologic-benelux.nl

Switzerland
Utilis AG
info@utilis.com

Canada
Mittmann Industrial Inc.
info@mittmann.com

India
Ulhas Patil
u.patil@wto-asia.com

Norway
Helge Karlsen Verktøy og Maskin AS
hkvm@hkvm.no

Taiwan
Kaiko Co., Ltd.
info@kaiko.com.tw

China
Shanghai Gangde
wtocando@yahoo.com

Israel
E.Y.A.R. Ltd.
boris@eyar.co.il

Polonia
ARCO Andrzej Rudenko
info@arcotools.pl

Turkey
MYK CNC MAKINA SAN. VE
huseyin.tatlidil@mykcnc.com.tr

Czech Republic
ALBA precision, spol. s.r.o.
info@albaprecision.cz

Italy
Prymark srl
commerciale@prymark.it

Romania
SC Elif Trading SRL
bulent.ozkan@eliftrading.com

Ukraine
„LLC“ SPA Stankopromimport
info@phoenix-ua.com

Denmark
AVN Teknik A/S
cjo@avn.dk

Japan
NK Works Co. Ltd.
k_samba@nk-works.co.jp

Slowakia
ALBA precision s.r.o.
albaprecision@albaprecision.sk