

# Programme de porte-outils

QT/QTS 200, 250  
QT/QTS 100 M/MY/MS/MSY  
QT/QTS 200, 250 M/MY/MS/MSY  
QT 200, 250 M/MY/MS/MSY (16D)  
QT/QTS 300, 350  
QT/QTS 300-400 M/MY/MS/MSY  
QTC/QTE/QTU 100-350 M/MY/MS/MSY  
QT/QTN 100 MS/MSY (VDI)  
QT/QTN 200, 250 MS/MSY (VDI)  
QT/QTN 300-450 MSY (VDI)  
Hyper Quadrex 100, 150 MSY  
Hyper Quadrex 200, 250 MSY  
Integrex i-250, 350, 450H ST  
Integrex i-250, 350, 450H ST (VDI)

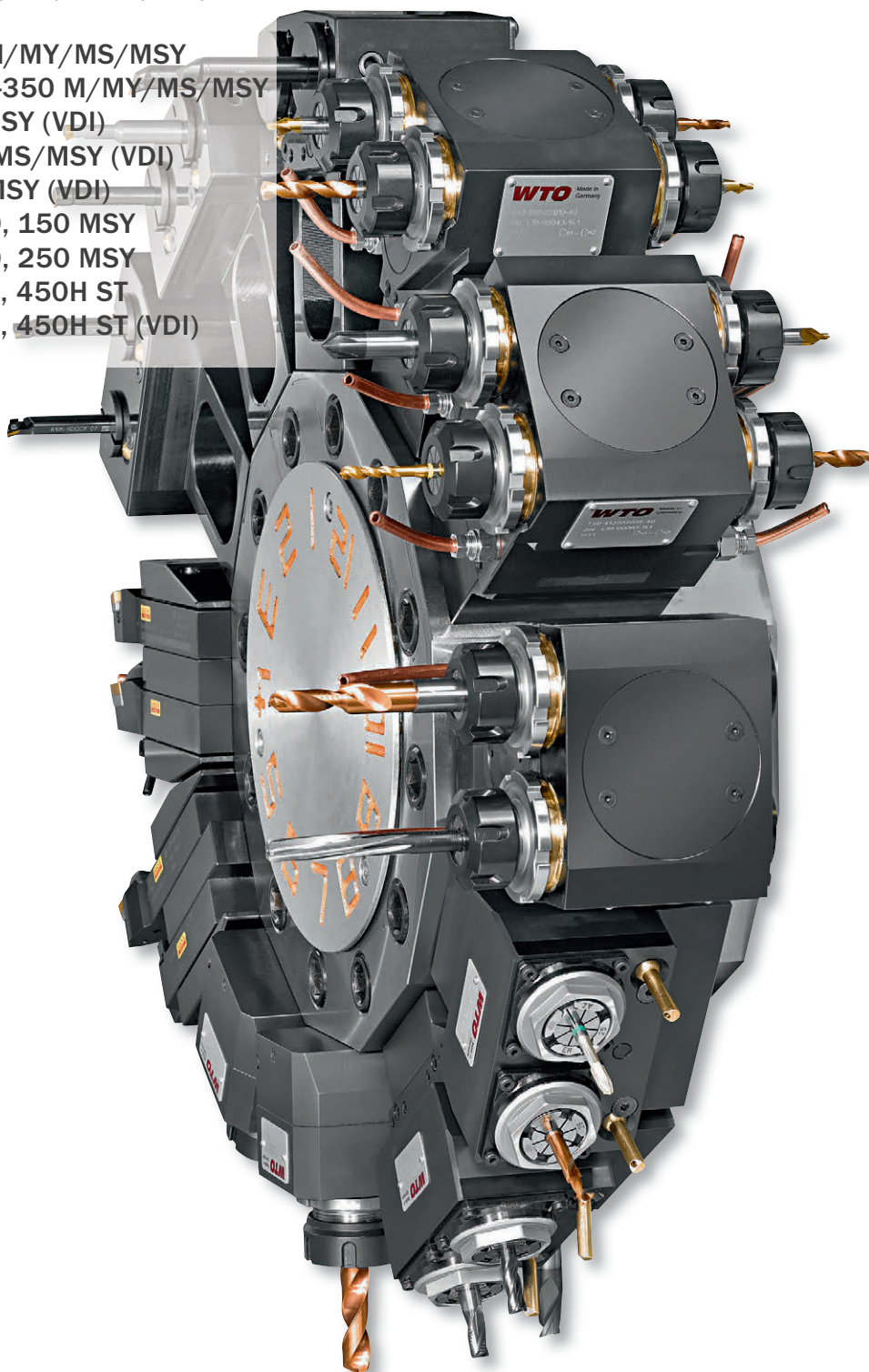

**Mazak**

## QuickFlex®

Le nouveau système de changement rapide pour haute performance et précision.

Investissement minimal, possibilité d'extension maximale.

Développé  
pour

**Mazak**

QT/QTS 200, 250	Page	4 - 4
QT/QTS 100 M/MY/MS/MSY	Page	5 - 7
QT/QTS 200, 250 M/MY/MS/MSY	Page	8 - 11
QT 200, 250 M/MY/MS/MSY (16D)	Page	12 - 14
QT/QTS 300, 350	Page	15 - 15
QT/QTS 300-400 M/MY/MS/MSY	Page	16 - 17
QTC/QTE/QTU 100-350 M/MY/MS/MSY	Page	18 - 21
QT/QTN 100 MS/MSY (VDI)	Page	22 - 24
QT/QTN 200, 250 MS/MSY (VDI)	Page	25 - 27
QT/QTN 300-450 MSY (VDI)	Page	28 - 30
Hyper Quadrex 100, 150 MSY	Page	31 - 34
Hyper Quadrex 200, 250 MSY	Page	35 - 38
Integrex i-250, 350, 450H ST	Page	39 - 39
Integrex i-250, 350, 450H ST (VDI)	Page	40 - 42
Douilles de réduction	Page	43 - 43
Pinces	Page	44 - 46

**EC = Arrosage externe**

**HP-IC = Arrosage interne haute pression par l'intérieur de l'outil coupant**

**IC 80 bar = Arrosage interne et externe**

Pression maximale = 80 bar

**IC 30 bar = Arrosage interne et externe**

Pression maximale = 30 bar

Utiliser uniquement du fluide filtré (taille max. de particules = 50 µm)

Ne pas faire tourner sans arrosage!

Ne pas utiliser pour l'usinage de matériaux abrasifs,  
comme de la fonte grise par exemple.

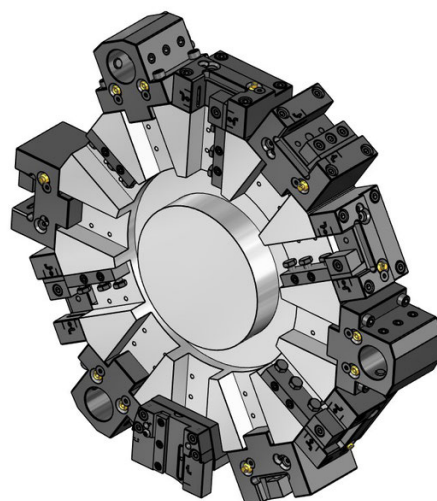
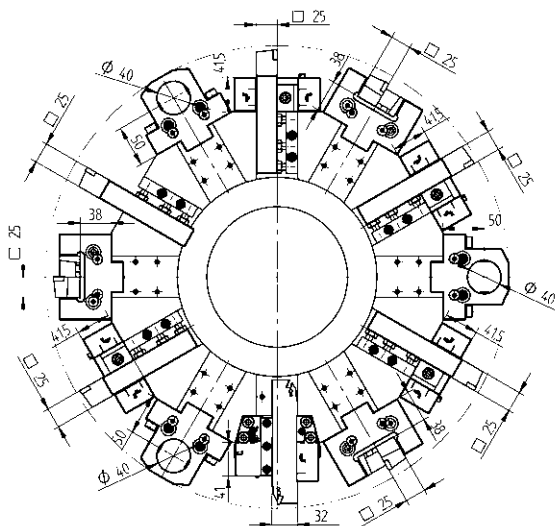

Porte-outils fixes - Programme standard

Porte-outils fixes - Programme élargi



**Porte-outil radial, HP-IC**  
 25      48-100805-HP      IC 80 bar



**Porte-outil de tronçonnage, réglable**  
 SH 32      48-100495



**Porte-outil axial, HP-IC**  
 25      48-100821-HP      IC 80 bar



**Porte-outil de tronçonnage, réglable, HP-IC**  
 SH 32      48-102270R      IC 80 bar  
 SH 32      48-102270L      IC 80 bar



**Porte-outil combiné**  
 Ø 40      48-115938      IC 80 bar

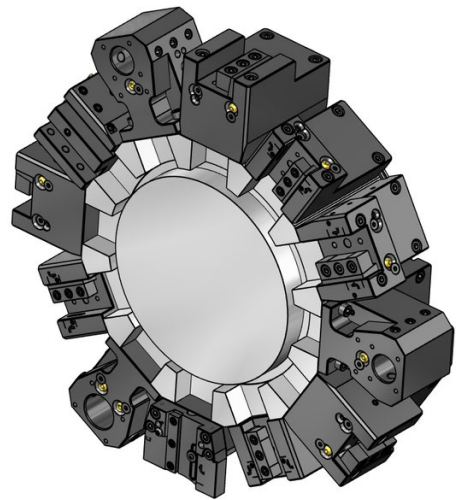
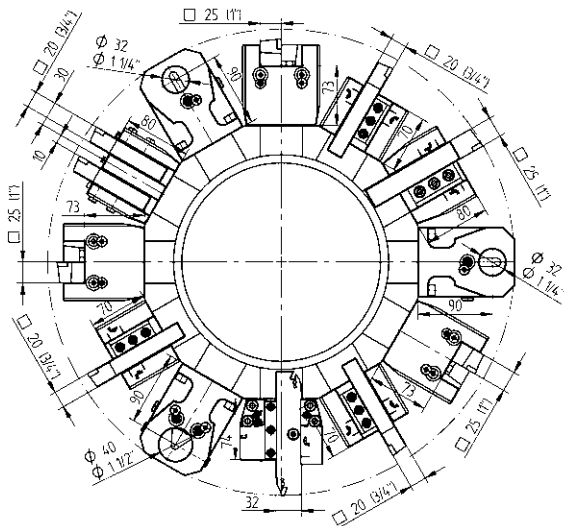

Porte-outils fixes - Programme standard



**Porte-outil radial, HP-IC**

<b>20</b>	48-107026-HP	IC 80 bar
<b>25</b>	48-91361-HP	IC 80 bar



**Porte-outil radial, deux côtés, HP-IC**

<b>25</b>	48-106347-HP	IC 80 bar
-----------	--------------	-----------



**Porte-outil axial**

<b>25</b>	48-91363
-----------	----------



**Porte-outil axial, deux côtés**

<b>25</b>	48-107240
-----------	-----------



**Porte-outil combiné, universel, LF=90**

<b>Ø 32</b>	48-106763	IC 80 bar
	241132016 ER25	
	241132020 ER32	
<b>Ø 40</b>	48-107209	IC 80 bar
	241140020 ER32	



**Bouchon**

48-106936
-----------

Porte-outils fixes - Programme élargi



**Porte-outil radial, double, axe Y**

<b>20 (3/4")</b>	48-106582
------------------	-----------



**Porte-outil radial, deux côtés, double, axe Y**

<b>20 (3/4")</b>	48-106575
------------------	-----------



**Porte-outil de tronçonnage, réglable**

<b>SH 32</b>	48-112064
--------------	-----------



**Porte-outil de tronçonnage, réglable, HP-IC**

<b>SH 32</b>	48-112062R	IC 80 bar
<b>SH 32</b>	48-112062L	IC 80 bar

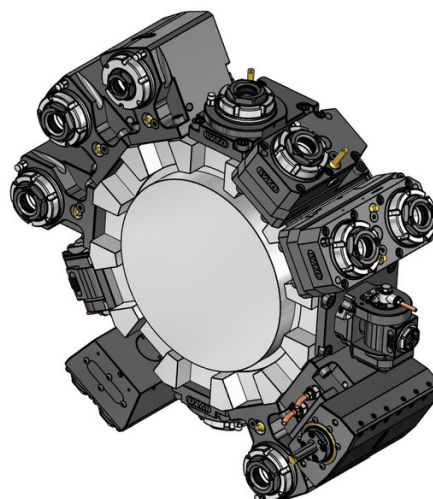
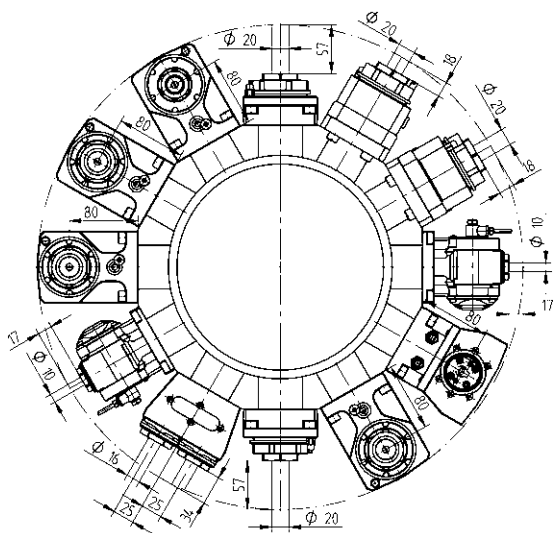

Porte-outils entrainés - QuickFlex®



**Porte-outil d'alésage et de fraisage droit**

- ER-32 QF 420132012-68 1:1 EC  
0067732000
- ER-32 QF 420132013-68 1:1 IC 80 bar  
0067732000



**Porte-outil d'alésage et de fraisage droit (12000 tr/min)**

- ER-32 QF 420132016-68 1:1 EC  
0067732000
- ER-32 QF 420132017-68 1:1 IC 80 bar  
0067732000



**Porte-outil d'alésage et de fraisage à renvoi d'angle**

- ER-32 QF 420532012-68 1:1 EC  
0067732000
- ER-32 QF 420532013-68 1:1 IC 80 bar  
0067732000



**Porte-outil d'alésage et de fraisage à renvoi d'angle (12000 tr/min)**

- ER-32 QF 420532020-68 1:1 EC  
0067732000
- ER-32 QF 420532021-68 1:1 IC 80 bar  
0067732000

Porte-outils entrainés - Programme élargi



**Porte-outil d'alésage et de fraisage droit décalé**

- ER-32 QF 420132018-68 1:1 EC  
0067732000
- ER-32 QF 420132019-68 1:1 IC 80 bar  
0067732000
- ER-25 QF 420125010-68 1:2 EC  
0067725001
- ER-25 QF 420125011-68 1:2 IC 80 bar  
0067725001
- ER-32 QF 420132020-68 2:1 EC  
0067732000
- ER-32 QF 420132021-68 2:1 IC 80 bar  
0067732000



**Porte-outil d'alésage et de fraisage droit décalé (12000 tr/min)**

- ER-32 QF 420132022-68 1:1 EC  
0067732000
- ER-32 QF 420132023-68 1:1 IC 80 bar  
0067732000



**Porte-outil d'alésage et de fraisage droit décalé, deux côtés**

- ER-32 QF 423002010-68 1:1 EC  
0067732000
- ER-32 QF 423002011-68 1:1 IC 80 bar  
0067732000

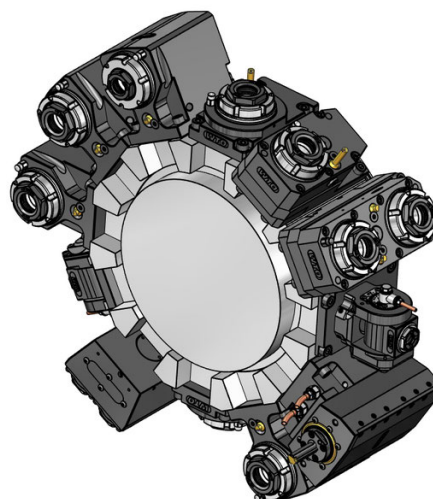
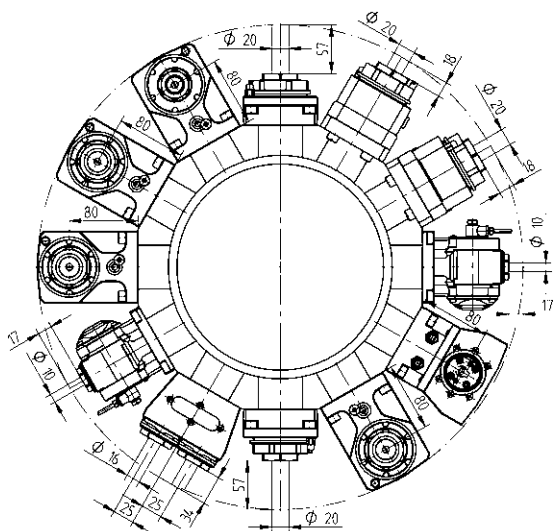

Porte-outils entrainés - Programme élargi



**Porte-outil d'alésage et de fraisage à renvoi d'angle**

<b>ER-25 QF</b>	420525010-68	1:2	EC
	0067725001		
<b>ER-25 QF</b>	420525011-68	1:2	IC 80 bar
	0067725001		
<b>ER-32 QF</b>	420532014-68	2:1	EC
	0067732000		
<b>ER-32 QF</b>	420532015-68	2:1	IC 80 bar
	0067732000		



**Porte-outil d'alésage et de fraisage à angle réglable**

<b>ER 16</b>	411010002-68	1:1	EC
	00675000913		
<b>ER 16</b>	411010003-68	1:1	IC 80 bar
	00675000913		
<b>ER 11</b>	411007002-68	1:2	EC
	00675000914		
<b>ER 11</b>	411007003-68	1:2	IC 80 bar
	00675000914		



**Porte-outil d'alésage et de fraisage droit, double, axe Y**

<b>ER 25</b>	413002008-68	1:1	EC
	00675000932		
<b>ER 25</b>	413002009-68	1:1	IC 80 bar
	00675000932		

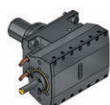

**Unité de brochage intérieur et extérieur**

<b>TN765050</b>	414532000-68	1:1	EC
-----------------	--------------	-----	----

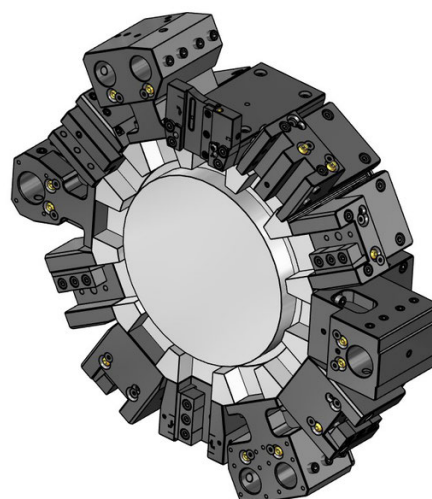
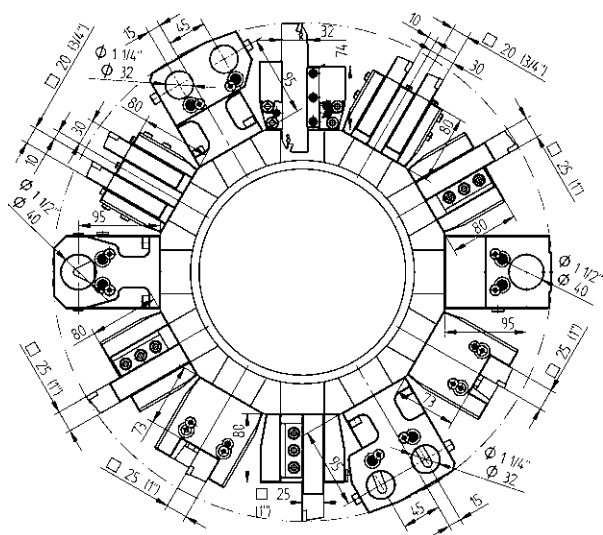

Porte-outils fixes - Programme standard



**Porte-outil radial, HP-IC**

20 48-107026-HP IC 80 bar  
 25 48-91361-HP IC 80 bar



**Porte-outil radial, deux côtés, HP-IC**

25 48-106347-HP IC 80 bar



**Porte-outil axial**

25 48-91363



**Porte-outil axial, deux côtés**

25 48-107240



**Porte-outil combiné, universel, LF=95**

Ø 40 48-107211 IC 80 bar  
 241140020 ER32



**Porte-outil combiné, deux côtés**

Ø 40 48-106346 IC 80 bar



**Bouchon**

48-106936

Porte-outils fixes - Programme élargi



**Porte-outil radial, double, axe Y**

20 (3/4") 48-106582



**Porte-outil radial, deux côtés, double, axe Y**

20 (3/4") 48-106575



**Porte-outil de tronçonnage, réglable**

SH 32 48-112064



**Porte-outil de tronçonnage, réglable, HP-IC**

SH 32 48-112062R IC 80 bar  
 SH 32 48-112062L IC 80 bar



**Porte-outil combiné, universel, double, axe Y**

Ø 32 48-106578  
 241132016 ER25  
 241132020 ER32



**Porte-outil combiné, deux côtés, double, axe Y**

Ø 32 48-106584 IC 80 bar



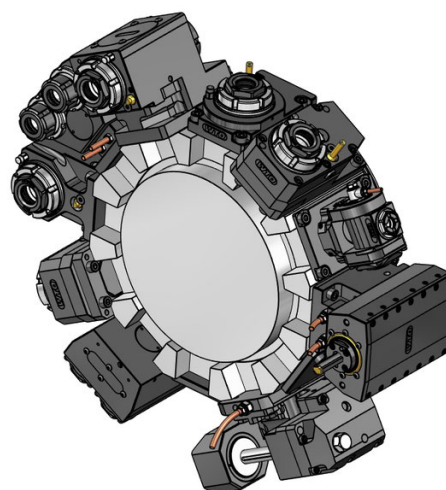
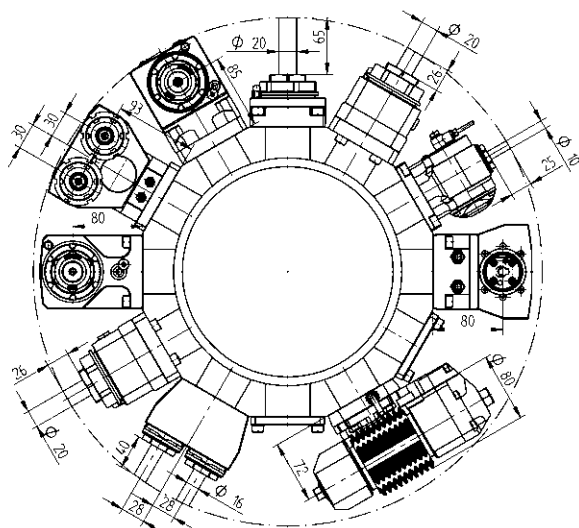

Porte-outils entraînés - QuickFlex®



**Porte-outil d'alésage et de fraisage droit**

- ER-32 QF 420132012-68 1:1 EC  
0067732000
- ER-32 QF 420132013-68 1:1 IC 80 bar  
0067732000



**Porte-outil d'alésage et de fraisage droit (12000 tr/min)**

- ER-32 QF 420132016-68 1:1 EC  
0067732000
- ER-32 QF 420132017-68 1:1 IC 80 bar  
0067732000



**Porte-outil d'alésage et de fraisage à renvoi d'angle**

- ER-32 QF 420532012-68 1:1 EC  
0067732000
- ER-32 QF 420532013-68 1:1 IC 80 bar  
0067732000



**Porte-outil d'alésage et de fraisage à renvoi d'angle (12000 tr/min)**

- ER-32 QF 420532020-68 1:1 EC  
0067732000
- ER-32 QF 420532021-68 1:1 IC 80 bar  
0067732000



**Porte-outil d'alésage et de fraisage à renvoi d'angle, broche de reprise**

- ER-32 QF 420532024-68 1:1 EC  
0067732000
- ER-32 QF 420532025-68 1:1 IC 80 bar  
0067732000

Porte-outils entraînés - QuickFlex®



**Porte-outil d'alésage et de fraisage à renvoi d'angle, broche de reprise (12000 tr/min)**

- ER-32 QF 420532022-68 1:1 EC  
0067732000
- ER-32 QF 420532023-68 1:1 IC 80 bar  
0067732000



**Porte-outil d'alésage et de fraisage à renvoi d'angle, deux côtés**

- ER-32 QF 420532026-68 1:1 EC  
0067732000



**Porte-outil d'alésage et de fraisage à renvoi d'angle, deux côtés (12000 tr/min)**

- ER-32 QF 420532019-68 1:1 EC  
0067732000

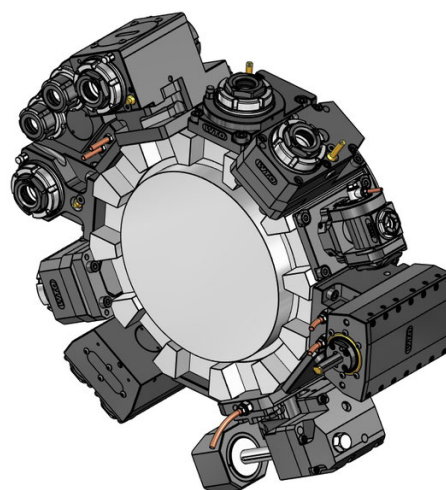
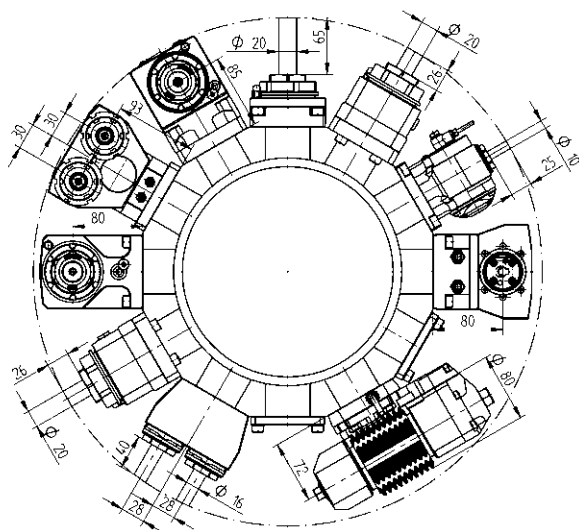

Porte-outils entrainés - Programme élargi



**Porte-outil d'alésage et de fraisage droit décalé**

<b>ER-32 QF</b>	420132018-68	1:1	EC
	0067732000		
<b>ER-32 QF</b>	420132019-68	1:1	IC 80 bar
	0067732000		
<b>ER-25 QF</b>	420125010-68	1:2	EC
	0067725001		
<b>ER-25 QF</b>	420125011-68	1:2	IC 80 bar
	0067725001		
<b>ER-32 QF</b>	420132020-68	2:1	EC
	0067732000		
<b>ER-32 QF</b>	420132021-68	2:1	IC 80 bar
	0067732000		



**Porte-outil d'alésage et de fraisage droit décalé (12000 tr/min)**

<b>ER-32 QF</b>	420132022-68	1:1	EC
	0067732000		
<b>ER-32 QF</b>	420132023-68	1:1	IC 80 bar
	0067732000		



**Porte-outil d'alésage et de fraisage droit décalé, deux côtés**

<b>ER-32 QF</b>	423002010-68	1:1	EC
	0067732000		
<b>ER-32 QF</b>	423002011-68	1:1	IC 80 bar
	0067732000		

Porte-outils entrainés - Programme élargi



**Porte-outil d'alésage et de fraisage à renvoi d'angle**

<b>ER-25 QF</b>	420525010-68	1:2	EC
	0067725001		
<b>ER-25 QF</b>	420525011-68	1:2	IC 80 bar
	0067725001		
<b>ER-32 QF</b>	420532014-68	2:1	EC
	0067732000		
<b>ER-32 QF</b>	420532015-68	2:1	IC 80 bar
	0067732000		



**Porte-outil d'alésage et de fraisage à angle réglable**

<b>ER 16</b>	411010002-68	1:1	EC
	00675000913		
<b>ER 16</b>	411010003-68	1:1	IC 80 bar
	00675000913		
<b>ER 11</b>	411007002-68	1:2	EC
	00675000914		
<b>ER 11</b>	411007003-68	1:2	IC 80 bar
	00675000914		

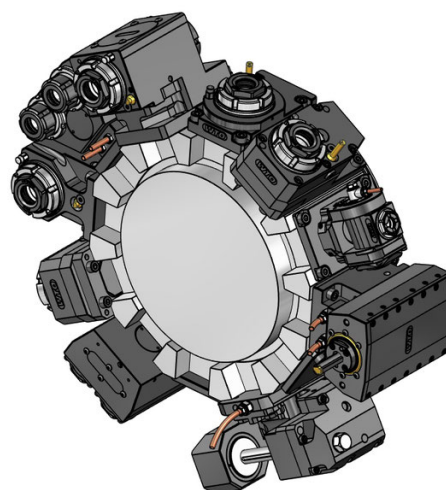
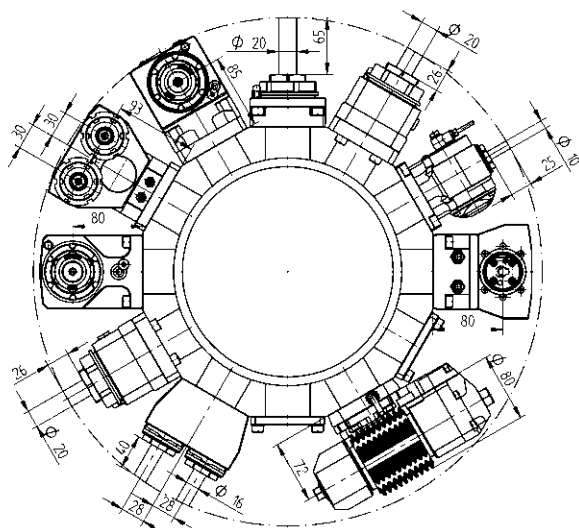

Porte-outils entraînés - Programme élargi



**Unité de taillage de dentures**

Type 16-1 411500007-68 1:1 EC

- 00675000926
- 160016161 Ø 16
- 160022161 Ø 22
- 160027161 Ø 27
- 160015161 Ø 5/8"
- 160019161 Ø 3/4"
- 160025161 Ø 1"
- 160031161 Ø 1 1/4"
- 110587

Type 16-1 411500008-68 2:1 EC

- 00675000926
- 160016161 Ø 16
- 160022161 Ø 22
- 160027161 Ø 27
- 160015161 Ø 5/8"
- 160019161 Ø 3/4"
- 160025161 Ø 1"
- 160031161 Ø 1 1/4"
- 110587



**Porte-outil d'alésage et de fraisage droit, double, axe Y**

ER 25 413002008-68 1:1 EC

- 00675000932

ER 25 413002009-68 1:1 IC 80 bar

- 00675000932

Porte-outils entraînés - Programme élargi



**Porte-outil d'alésage et de fraisage à renvoi d'angle double, axe Y**

ER 25 413502005-68 1:1 EC

- 00675000915

ER 25 413502006-68 1:1 IC 80 bar

- 00675000915



**Porte-outil d'alésage et de fraisage à renvoi d'angle double, deux côtés, axe Y**

ER 25 413502007-68 1:1 EC

- 00675000915



**Unité de brochage intérieur et extérieur**

TN765050 414532000-68 1:1 EC

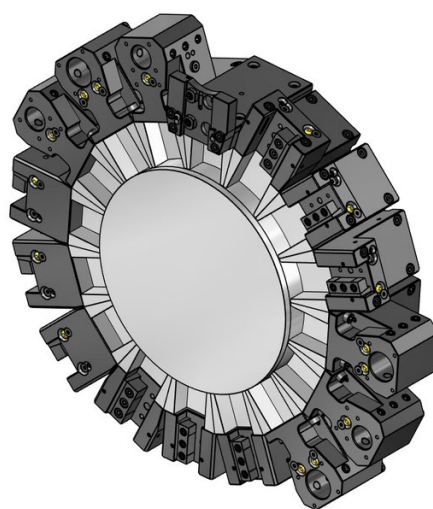
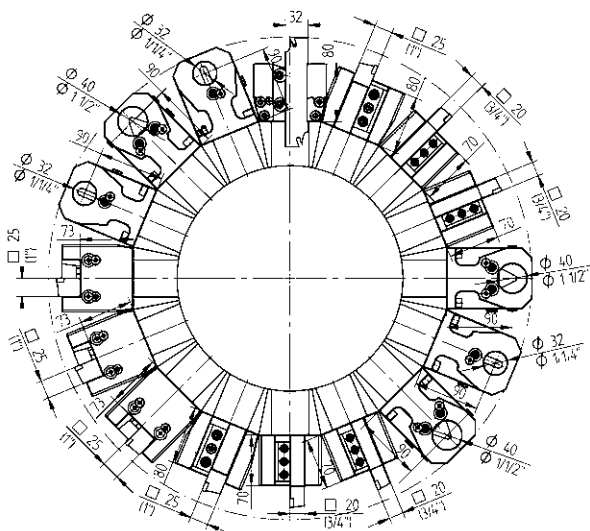

Porte-outils fixes - Programme standard



**Porte-outil radial, HP-IC**

20 48-107026-HP IC 80 bar  
 25 48-91361-HP IC 80 bar



**Porte-outil radial, deux côtés, HP-IC**

25 48-106347-HP IC 80 bar



**Porte-outil axial**

25 48-91363



**Porte-outil combiné, universel, LF=90**

Ø 32 48-106763 IC 80 bar  
 241132016 ER25  
 241132020 ER32  
 Ø 40 48-107209 IC 80 bar  
 241140020 ER32



**Bouchon**

48-106936

Porte-outils fixes - Programme élargi



**Porte-outil radial, double, axe Y**

20 (3/4") 48-106582



**Porte-outil radial, deux côtés, double, axe Y**

20 (3/4") 48-106575



**Porte-outil de tronçonnage, réglable**

SH 32 48-112064



**Porte-outil de tronçonnage, réglable, HP-IC**

SH 32 48-112062R IC 80 bar  
 SH 32 48-112062L IC 80 bar

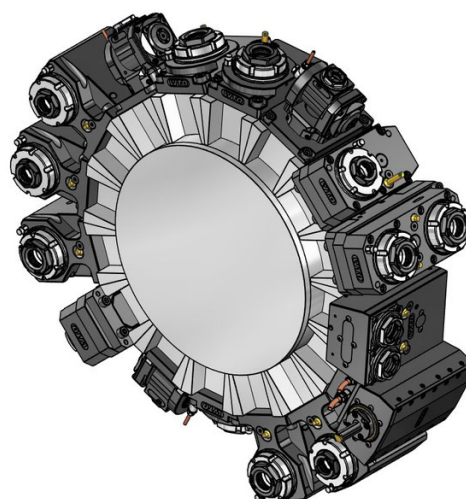
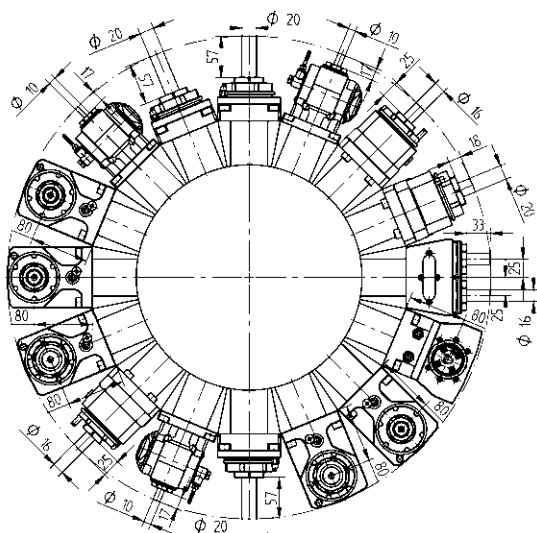

Porte-outils entrainés - QuickFlex®



**Porte-outil d'alésage et de fraisage droit**

- ER-32 QF 420132012-68 1:1 EC  
0067732000
- ER-32 QF 420132013-68 1:1 IC 80 bar  
0067732000



**Porte-outil d'alésage et de fraisage droit (12000 tr/min)**

- ER-32 QF 420132016-68 1:1 EC  
0067732000
- ER-32 QF 420132017-68 1:1 IC 80 bar  
0067732000



**Porte-outil d'alésage et de fraisage à renvoi d'angle**

- ER-32 QF 420532012-68 1:1 EC  
0067732000
- ER-32 QF 420532013-68 1:1 IC 80 bar  
0067732000



**Porte-outil d'alésage et de fraisage à renvoi d'angle (12000 tr/min)**

- ER-32 QF 420532020-68 1:1 EC  
0067732000
- ER-32 QF 420532021-68 1:1 IC 80 bar  
0067732000

Porte-outils entrainés - Programme élargi



**Porte-outil d'alésage et de fraisage droit décalé**

- ER-32 QF 420132018-68 1:1 EC  
0067732000
- ER-32 QF 420132019-68 1:1 IC 80 bar  
0067732000
- ER-25 QF 420125010-68 1:2 EC  
0067725001
- ER-25 QF 420125011-68 1:2 IC 80 bar  
0067725001
- ER-32 QF 420132020-68 2:1 EC  
0067732000
- ER-32 QF 420132021-68 2:1 IC 80 bar  
0067732000



**Porte-outil d'alésage et de fraisage droit décalé (12000 tr/min)**

- ER-32 QF 420132022-68 1:1 EC  
0067732000
- ER-32 QF 420132023-68 1:1 IC 80 bar  
0067732000



**Porte-outil d'alésage et de fraisage droit décalé, deux côtés**

- ER-32 QF 423002010-68 1:1 EC  
0067732000
- ER-32 QF 423002011-68 1:1 IC 80 bar  
0067732000

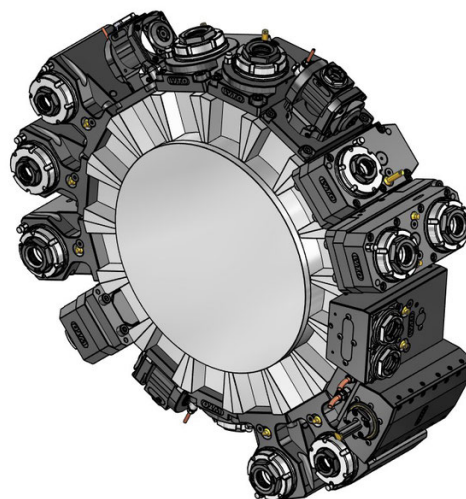
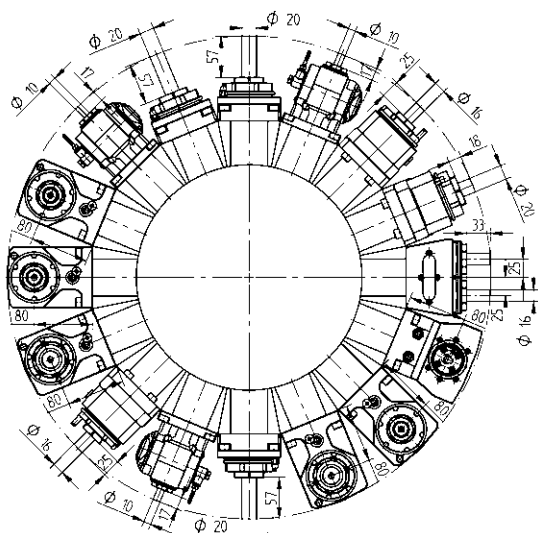

Porte-outils entrainés - Programme élargi



**Porte-outil d'alésage et de fraisage à renvoi d'angle**

<b>ER-25 QF</b>	420525010-68	1:2	EC
	0067725001		
<b>ER-25 QF</b>	420525011-68	1:2	IC 80 bar
	0067725001		
<b>ER-32 QF</b>	420532014-68	2:1	EC
	0067732000		
<b>ER-32 QF</b>	420532015-68	2:1	IC 80 bar
	0067732000		



**Porte-outil d'alésage et de fraisage à angle réglable**

<b>ER 16</b>	411010002-68	1:1	EC
	00675000913		
<b>ER 16</b>	411010003-68	1:1	IC 80 bar
	00675000913		
<b>ER 11</b>	411007002-68	1:2	EC
	00675000914		
<b>ER 11</b>	411007003-68	1:2	IC 80 bar
	00675000914		



**Porte-outil d'alésage et de fraisage droit, double, axe Y**

<b>ER 25</b>	413002008-68	1:1	EC
	00675000932		
<b>ER 25</b>	413002009-68	1:1	IC 80 bar
	00675000932		



**Unité de brochage intérieur et extérieur**

<b>TN765050</b>	414532000-68	1:1	EC
-----------------	--------------	-----	----

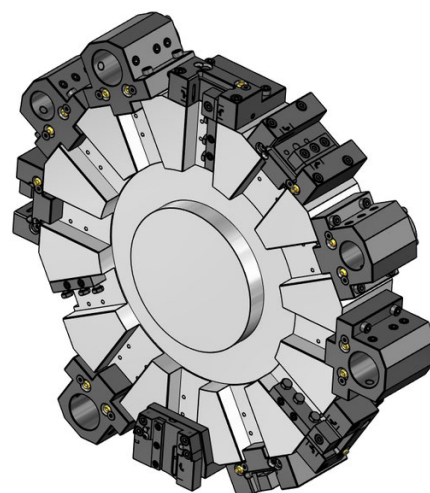
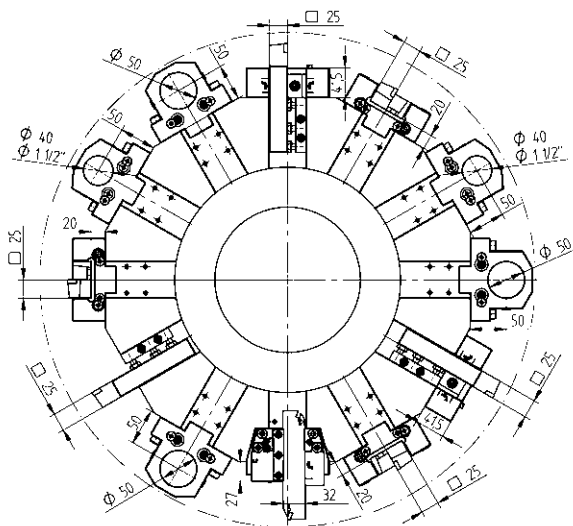

Porte-outils fixes - Programme standard

Porte-outils fixes - Programme élargi



**Porte-outil radial, HP-IC**  
 25 48-100839-HP IC 80 bar



**Porte-outil de tronçonnage, réglable**  
 SH 32 48-100556

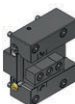

**Porte-outil axial, HP-IC**  
 25 48-100861-HP IC 80 bar



**Porte-outil de tronçonnage, réglable, HP-IC**  
 SH 32 48-102272R IC 80 bar  
 SH 32 48-102272L IC 80 bar



**Porte-outil combiné**  
 Ø 40 48-112681 IC 80 bar



**Porte-outil combiné**  
 Ø 50 48-112682 IC 80 bar

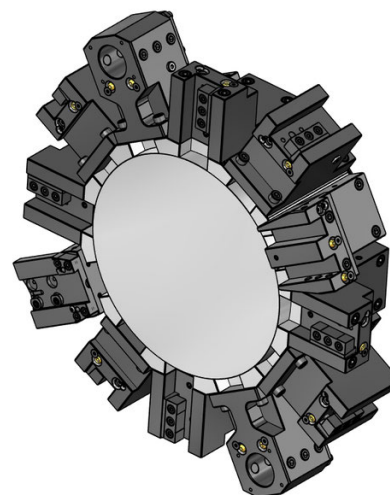
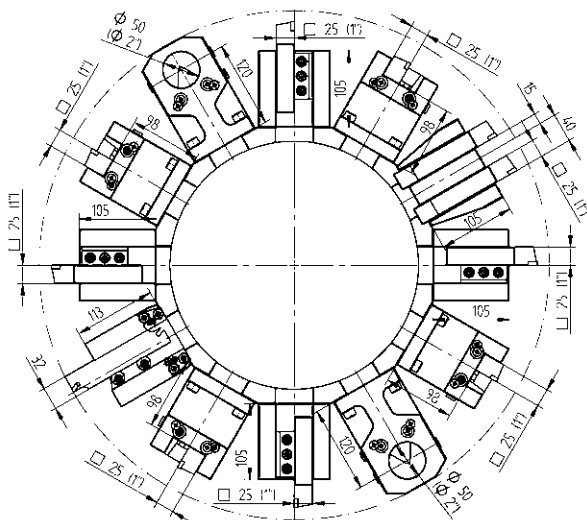

Porte-outils fixes - Programme standard



**Porte-outil radial, HP-IC**  
 25 48-93004-HP IC 80 bar



**Porte-outil radial, deux côtés, HP-IC**  
 25 48-109600-HP IC 80 bar



**Porte-outil axial**  
 25 48-93006



**Porte-outil combiné**  
 Ø 50 48-93008 IC 80 bar



**Porte-outil combiné, deux côtés**  
 Ø 40 48-109611 IC 80 bar  
 241140026 ER40

Porte-outils fixes - Programme élargi



**Porte-outil radial, double, axe Y**  
 25(1") 48-109633



**Porte-outil de tronçonnage, réglable**  
 SH 32 48-93039



**Porte-outil de tronçonnage, réglable, HP-IC**  
 SH 32 48-99401R IC 80 bar  
 343-810100R12  
 SH 32 48-99401L IC 80 bar  
 343-810100L12



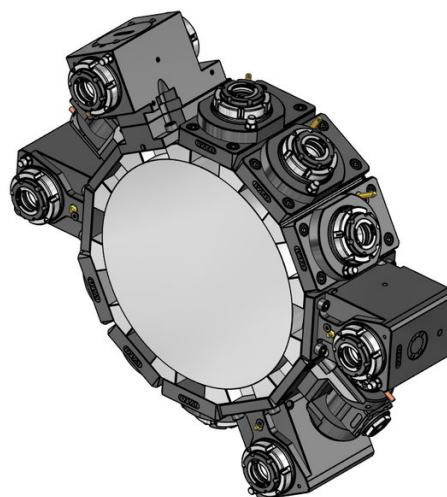
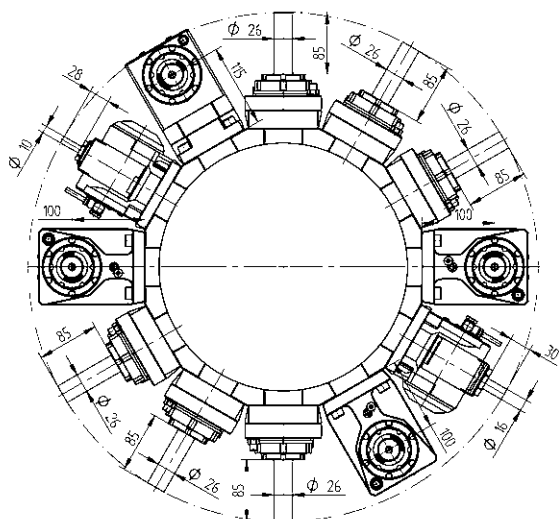

Porte-outils entrainés - QuickFlex®

Porte-outils entrainés - Programme élargi



**Porte-outil d'alésage et de fraisage droit**

- ER-40 QF 420140010-80 1:1 EC  
0067740000
- ER-40 QF 420140011-80 1:1 IC 80 bar  
0067740000



**Porte-outil d'alésage et de fraisage droit (10000 tr/min)**

- ER-40 QF 420140012-80 1:1 EC  
0067740000
- ER-40 QF 420140013-80 1:1 IC 80 bar  
0067740000



**Porte-outil d'alésage et de fraisage à renvoi d'angle**

- ER-40 QF 420540010-80 1:1 EC  
0067740000
- ER-40 QF 420540011-80 1:1 IC 80 bar  
0067740000



**Porte-outil d'alésage et de fraisage à renvoi d'angle (10000 tr/min)**

- ER-40 QF 420540014-80 1:1 EC  
0067740000
- ER-40 QF 420540015-80 1:1 IC 80 bar  
0067740000



**Porte-outil d'alésage et de fraisage à renvoi d'angle, broche de reprise (10000 tr/min)**

- ER-40 QF 420540016-80 1:1 EC  
0067740000
- ER-40 QF 420540017-80 1:1 IC 80 bar  
0067740000



**Porte-outil d'alésage et de fraisage à renvoi d'angle, deux côtés (10000 tr/min)**

- ER-40 QF 420540018-80 1:1 EC  
0067740000



**Porte-outil d'alésage et de fraisage à renvoi d'angle**

- ER-32 QF 420532010-80 1:2 EC  
0067732001
- ER-32 QF 420532011-80 1:2 IC 80 bar  
0067732001

- ER-40 QF 420540012-80 2:1 EC  
0067740000
- ER-40 QF 420540013-80 2:1 IC 80 bar  
0067740000



**Porte-outil d'alésage et de fraisage à angle réglable**

- ER 25 411016000-80 1:1 EC  
00675000934
- ER 25 411016001-80 1:1 IC 80 bar  
00675000934
- ER 16 411010001-80 1:2 EC  
00675000936
- ER 16 411010002-80 1:2 IC 80 bar  
00675000936

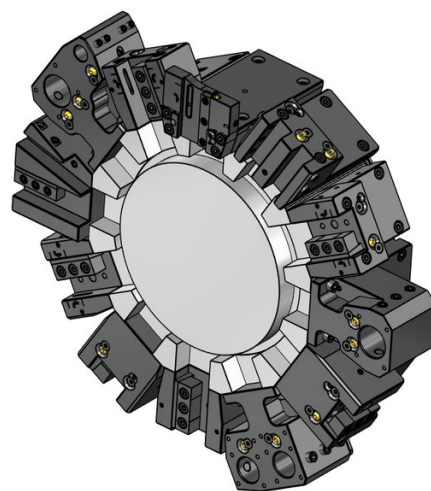
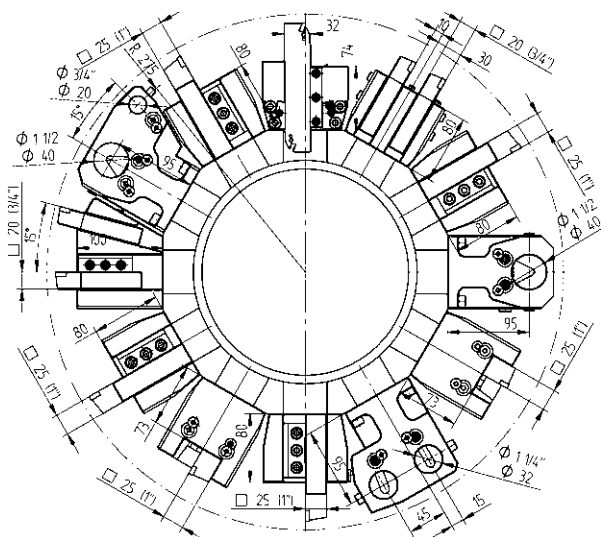

Porte-outils fixes - Programme standard

- 

**Porte-outil radial, HP-IC**  
 20 48-107026-HP IC 80 bar  
 25 48-91361-HP IC 80 bar
- 

**Porte-outil radial, deux côtés, HP-IC**  
 25 48-106347-HP IC 80 bar
- 

**Porte-outil axial**  
 25 48-91363
- 

**Porte-outil axial, deux côtés**  
 25 48-107240
- 

**Porte-outil combiné, universel, LF=95**  
 Ø 40 48-107211 IC 80 bar  
 241140020 ER32
- 

**Porte-outil combiné, deux côtés**  
 Ø 40 48-106346 IC 80 bar
- 

**Bouchon**  
 48-106936

Porte-outils fixes - Programme élargi

- 

**Porte-outil radial, double, 24 stations**  
 20 48-111240
- 

**Porte-outil radial, double, axe Y**  
 20 (3/4") 48-106582
- 

**Porte-outil radial, deux côtés, double, axe Y**  
 20 (3/4") 48-106575
- 

**Porte-outil de tronçonnage, réglable**  
 SH 32 48-112064
- 

**Porte-outil de tronçonnage, réglable, HP-IC**  
 SH 32 48-112062R IC 80 bar  
 SH 32 48-112062L IC 80 bar
- 

**Porte-outil combiné, universel, double, 24 stations**  
 Ø40/20 48-111242 IC 80 bar
- 

**Porte-outil combiné, universel, double, axe Y**  
 Ø 32 48-106578  
 241132016 ER25  
 241132020 ER32
- 

**Porte-outil combiné, deux côtés, double, axe Y**  
 Ø 32 48-106584 IC 80 bar

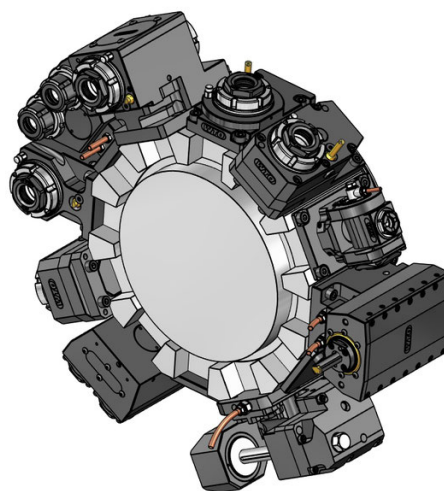
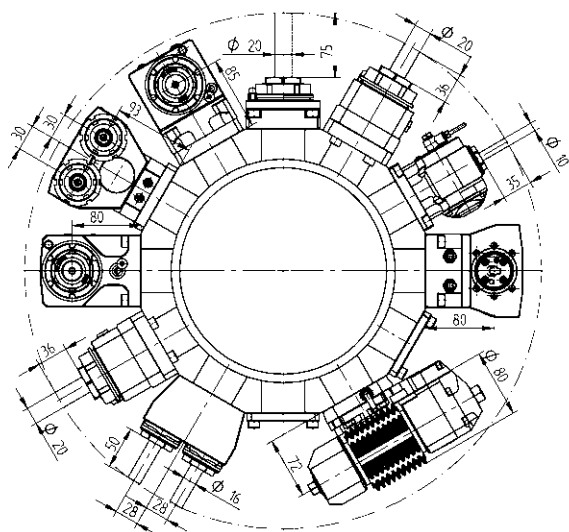

Porte-outils entraînés - QuickFlex®



**Porte-outil d'alésage et de fraisage droit**

- ER-32 QF 420132012-68 1:1 EC  
0067732000
- ER-32 QF 420132013-68 1:1 IC 80 bar  
0067732000



**Porte-outil d'alésage et de fraisage droit (12000 tr/min)**

- ER-32 QF 420132016-68 1:1 EC  
0067732000
- ER-32 QF 420132017-68 1:1 IC 80 bar  
0067732000



**Porte-outil d'alésage et de fraisage à renvoi d'angle**

- ER-32 QF 420532012-68 1:1 EC  
0067732000
- ER-32 QF 420532013-68 1:1 IC 80 bar  
0067732000



**Porte-outil d'alésage et de fraisage à renvoi d'angle (12000 tr/min)**

- ER-32 QF 420532020-68 1:1 EC  
0067732000
- ER-32 QF 420532021-68 1:1 IC 80 bar  
0067732000



**Porte-outil d'alésage et de fraisage à renvoi d'angle, broche de reprise**

- ER-32 QF 420532024-68 1:1 EC  
0067732000
- ER-32 QF 420532025-68 1:1 IC 80 bar  
0067732000

Porte-outils entraînés - QuickFlex®



**Porte-outil d'alésage et de fraisage à renvoi d'angle, broche de reprise (12000 tr/min)**

- ER-32 QF 420532022-68 1:1 EC  
0067732000
- ER-32 QF 420532023-68 1:1 IC 80 bar  
0067732000



**Porte-outil d'alésage et de fraisage à renvoi d'angle, deux côtés**

- ER-32 QF 420532026-68 1:1 EC  
0067732000



**Porte-outil d'alésage et de fraisage à renvoi d'angle, deux côtés (12000 tr/min)**

- ER-32 QF 420532019-68 1:1 EC  
0067732000

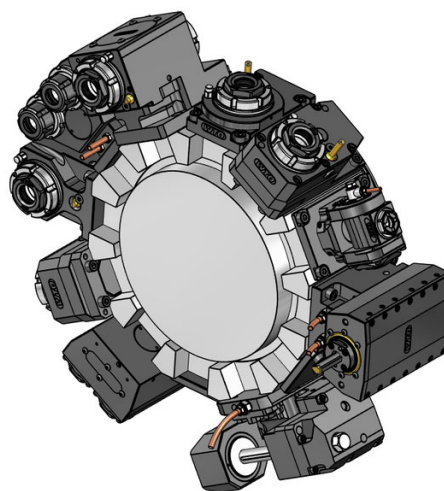
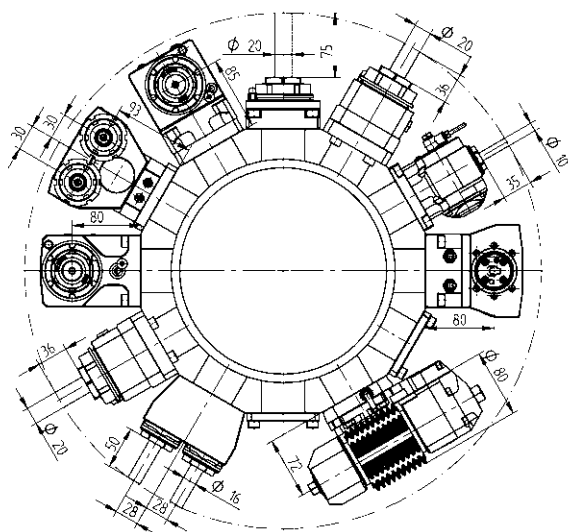

Porte-outils entrainés - Programme élargi



**Porte-outil d'alésage et de fraisage droit décalé**

<b>ER-32 QF</b>	420132018-68	1:1	EC
	0067732000		
<b>ER-32 QF</b>	420132019-68	1:1	IC 80 bar
	0067732000		
<b>ER-25 QF</b>	420125010-68	1:2	EC
	0067725001		
<b>ER-25 QF</b>	420125011-68	1:2	IC 80 bar
	0067725001		
<b>ER-32 QF</b>	420132020-68	2:1	EC
	0067732000		
<b>ER-32 QF</b>	420132021-68	2:1	IC 80 bar
	0067732000		



**Porte-outil d'alésage et de fraisage droit décalé (12000 tr/min)**

<b>ER-32 QF</b>	420132022-68	1:1	EC
	0067732000		
<b>ER-32 QF</b>	420132023-68	1:1	IC 80 bar
	0067732000		



**Porte-outil d'alésage et de fraisage droit décalé, deux côtés**

<b>ER-32 QF</b>	423002010-68	1:1	EC
	0067732000		
<b>ER-32 QF</b>	423002011-68	1:1	IC 80 bar
	0067732000		

Porte-outils entrainés - Programme élargi



**Porte-outil d'alésage et de fraisage à renvoi d'angle**

<b>ER-25 QF</b>	420525010-68	1:2	EC
	0067725001		
<b>ER-25 QF</b>	420525011-68	1:2	IC 80 bar
	0067725001		
<b>ER-32 QF</b>	420532014-68	2:1	EC
	0067732000		
<b>ER-32 QF</b>	420532015-68	2:1	IC 80 bar
	0067732000		



**Porte-outil d'alésage et de fraisage à angle réglable**

<b>ER 16</b>	411010002-68	1:1	EC
	00675000913		
<b>ER 16</b>	411010003-68	1:1	IC 80 bar
	00675000913		
<b>ER 11</b>	411007002-68	1:2	EC
	00675000914		
<b>ER 11</b>	411007003-68	1:2	IC 80 bar
	00675000914		

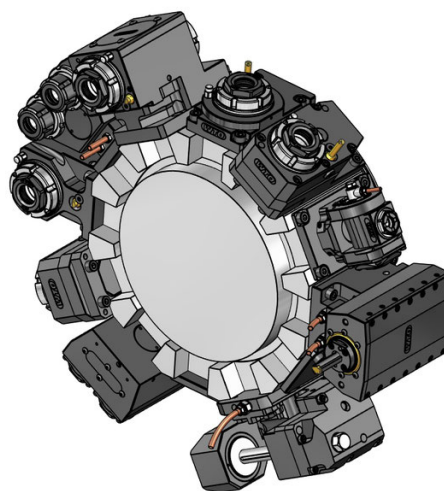
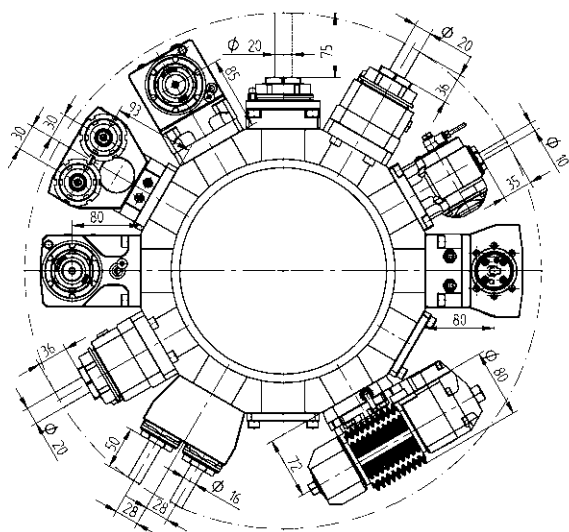

Porte-outils entraînés - Programme élargi



**Unité de taillage de dentures**

Type 16-1 411500007-68 1:1 EC

- 00675000926
- 160016161 Ø 16
- 160022161 Ø 22
- 160027161 Ø 27
- 160015161 Ø 5/8"
- 160019161 Ø 3/4"
- 160025161 Ø 1"
- 160031161 Ø 1 1/4"
- 110587

Type 16-1 411500008-68 2:1 EC

- 00675000926
- 160016161 Ø 16
- 160022161 Ø 22
- 160027161 Ø 27
- 160015161 Ø 5/8"
- 160019161 Ø 3/4"
- 160025161 Ø 1"
- 160031161 Ø 1 1/4"
- 110587



**Porte-outil d'alésage et de fraisage droit, double, axe Y**

ER 25 413002008-68 1:1 EC

- 00675000932

ER 25 413002009-68 1:1 IC 80 bar

- 00675000932

Porte-outils entraînés - Programme élargi



**Porte-outil d'alésage et de fraisage à renvoi d'angle double, axe Y**

ER 25 413502005-68 1:1 EC

- 00675000915

ER 25 413502006-68 1:1 IC 80 bar

- 00675000915



**Porte-outil d'alésage et de fraisage à renvoi d'angle double, deux côtés, axe Y**

ER 25 413502007-68 1:1 EC

- 00675000915



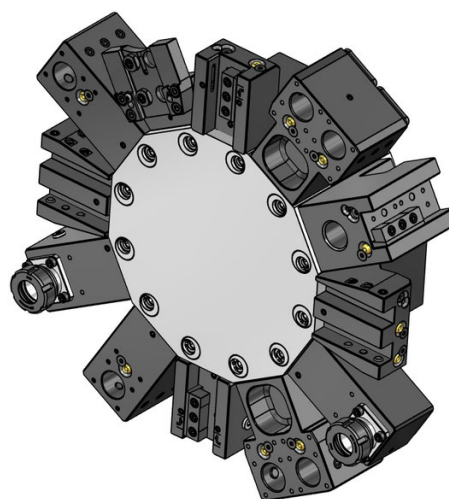
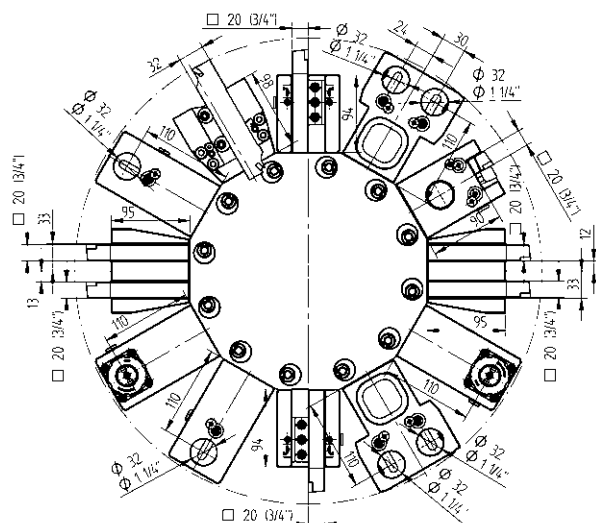

**Unité de brochage intérieur et extérieur**

TN765050 414532000-68 1:1 EC





Porte-outils fixes - Programme standard

- 

**Porte-outil radial, HP-IC**  
 20 48-82510-HP IC 80 bar
- 

**Porte-outil radial, deux côtés, HP-IC**  
 20 48-82511-HP IC 80 bar
- 

**Porte-outil axial**  
 20 48-84000
- 

**Porte-outil carré universel**  
 20 48-85368
- 

**Porte-outil combiné, universel**  
 Ø 32 48-82367  
 241132016 ER25  
 241132020 ER32
- 

**Porte-outil combiné, deux côtés**  
 Ø 32 48-82849
- 

**Porte-pince**  
 ER 32 48-83726  
 107532000
- 

**Porte-pince, deux côtés**  
 ER 32 48-83727  
 107532000

Porte-outils fixes - Programme élargi

- 

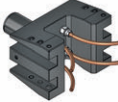
**Porte-outil radial, double, axe Y**  
 20 (3/4") 48-84958
- 

**Porte-outil radial, deux côtés, double, axe Y**  
 20 (3/4") 48-84959
- 

**Porte-outil de tronçonnage, réglable**  
 SH 32 48-99064 EC
- 

**Porte-outil de tronçonnage, réglable, HP-IC**  
 SH 32 48-99474R IC 80 bar  
 343-810100R13  
 SH 32 48-99474L IC 80 bar  
 343-810100L13
- 

**Porte-outil combiné, universel, double, axe Y**  
 Ø 32 48-84960  
 241132016 ER25  
 241132020 ER32

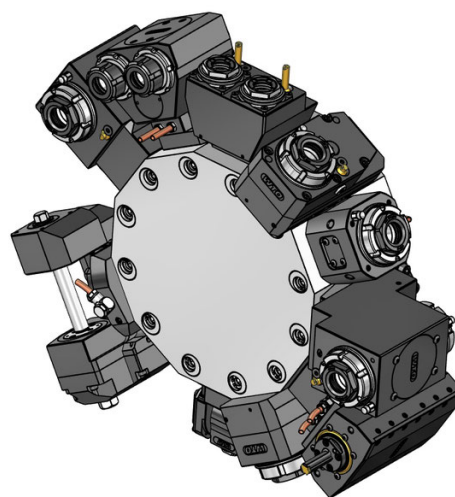
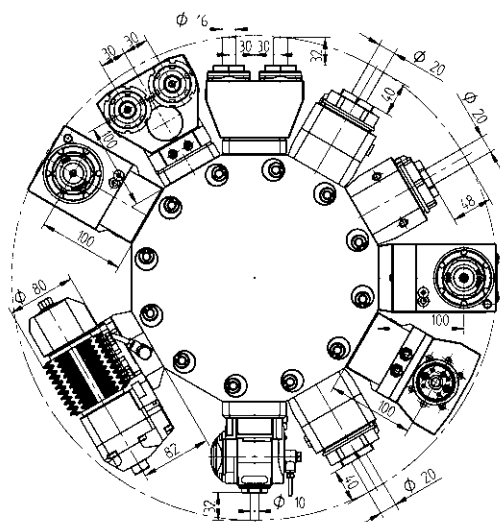



Porte-outils entrainés - QuickFlex®

- 

**Porte-outil d'alésage et de fraisage droit**  
**ER-32 QF** 420132040-40 1:1 EC  
 0067732000  
**ER-32 QF** 420132041-40 1:1 IC 80 bar  
 0067732000
- 

**Porte-outil d'alésage et de fraisage droit décalé**  
**ER-32 QF** 420132028-40 1:1 EC  
 0067732000  
**ER-32 QF** 420132029-40 1:1 IC 80 bar  
 0067732000
- 

**Porte-outil d'alésage et de fraisage à renvoi d'angle**  
**ER-32 QF** 420532066-40 1:1 EC  
 0067732000  
**ER-32 QF** 420532067-40 1:1 IC 80 bar  
 0067732000
- 

**Porte-outil d'alésage et de fraisage à renvoi d'angle, broche de reprise**  
**ER-32 QF** 420532068-40 1:1 EC  
 0067732000  
**ER-32 QF** 420532069-40 1:1 IC 80 bar  
 0067732000
- 

**Porte-outil d'alésage et de fraisage à renvoi d'angle, deux côtés**  
**ER-32 QF** 420532070-40 1:1 EC  
 0067732000

Porte-outils entrainés - Programme élargi

- 

**Porte-outil d'alésage et de fraisage droit décalé**  
**ER-25 QF** 420125020-40 1:2 EC  
 0067725001  
**ER-25 QF** 420125021-40 1:2 IC 80 bar  
 0067725001
- 

**ER-32 QF** 420132048-40 2:1 EC  
 0067732000  
**ER-32 QF** 420132049-40 2:1 IC 80 bar  
 0067732000
- 

**Porte-outil d'alésage et de fraisage droit décalé, deux côtés**  
**ER-32 QF** 423002014-40 1:1 EC  
 0067732000  
**ER-32 QF** 423002015-40 1:1 IC 80 bar  
 0067732000
- 

**Porte-outil d'alésage et de fraisage à renvoi d'angle**  
**ER-25 QF** 420525030-40 1:2 EC  
 0067725001  
**ER-25 QF** 420525031-40 1:2 IC 80 bar  
 0067725001  
**ER-32 QF** 420532085-40 2:1 EC  
 0067732000  
**ER-32 QF** 420532086-40 2:1 IC 80 bar  
 0067732000  
**ER 16** 410810000-40 1:3 EC  
 00675000841  
**ER 16** 410810001-40 1:3 IC 80 bar  
 00675000841

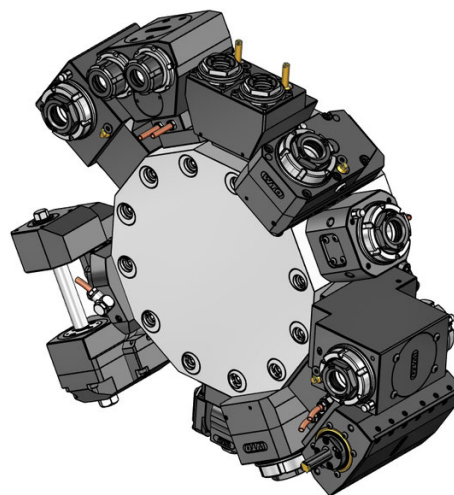
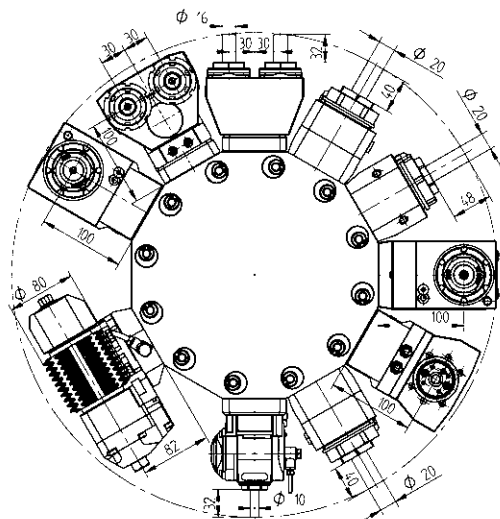

Porte-outils entraînés - Programme élargi



**Porte-outil d'alésage et de fraisage à angle réglable**

<b>ER 16</b>	411010005-40	1:1	EC
	00675000902		
<b>ER 16</b>	411010053-40	1:1	IC 80 bar
	00675000902		
<b>ER 11</b>	411007005-40	1:2	EC
	00675000914		
<b>ER 11</b>	411007006-40	1:2	IC 80 bar
	00675000914		



**Unité de taillage de dentures**

<b>Type 16-1</b>	411500029-40	2:1	EC
	00675000926		
	160016161 Ø 16		
	160022161 Ø 22		
	160027161 Ø 27		
	160015161 Ø 5/8"		
	160019161 Ø 3/4"		
	160025161 Ø 1"		
	160031161 Ø 1 1/4"		
	110587		

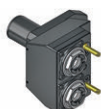

**Porte-outil d'alésage et de fraisage droit, double, axe Y**

<b>ER 25</b>	413002020-40	1:1,5	EC
	00675000930		
<b>ER 25</b>	413002021-40	1:1,5	IC 80 bar
	00675000930		

Porte-outils entraînés - Programme élargi

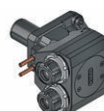

**Porte-outil d'alésage et de fraisage à renvoi d'angle double, axe Y**

<b>ER 25</b>	413502010-40	1:1	EC
	00675000915		
<b>ER 25</b>	413502011-40	1:1	IC 80 bar
	00675000915		



**Unité de brochage intérieur et extérieur**

<b>TN765050</b>	414532009-40	1:1	EC
-----------------	--------------	-----	----



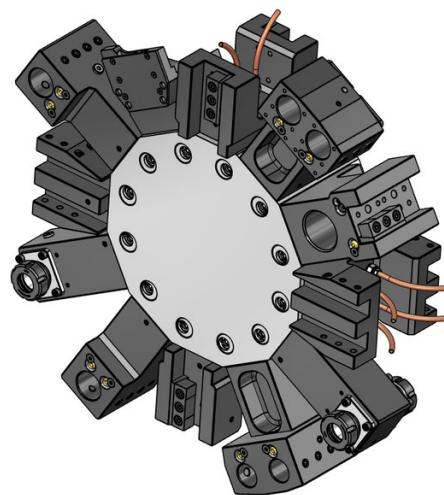
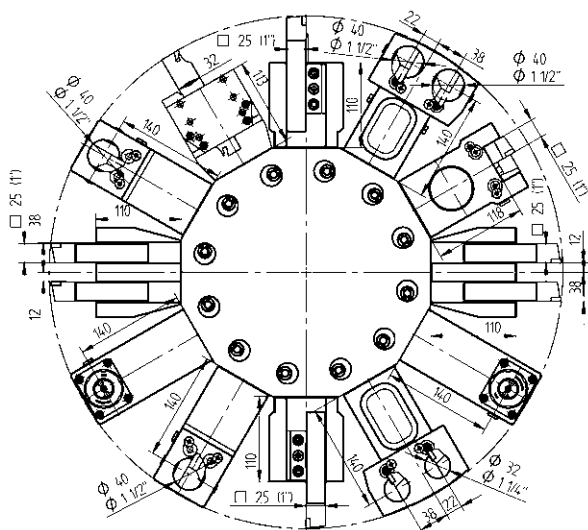



Porte-outils fixes - Programme standard

Porte-outils fixes - Programme élargi

- 

**Porte-outil radial, HP-IC**  
 25      48-82507-HP      IC 80 bar
- 

**Porte-outil radial, deux côtés, HP-IC**  
 25      48-82508-HP      IC 80 bar
- 

**Porte-outil axial**  
 25      48-83885
- 

**Porte-outil carré universel**  
 25      48-81932
- 

**Porte-outil combiné, universel**  
 Ø 40      48-82363  
             241140020 ER32
- 

**Porte-outil combiné, deux côtés**  
 Ø 40      48-82848
- 

**Porte-pince**  
 ER 32      48-83504  
             107532000
- 

**Porte-pince, deux côtés**  
 ER 32      48-83512  
             107532000

- 

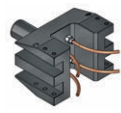
**Porte-outil radial, double, axe Y**  
 25(1")      48-84944
- 

**Porte-outil radial, deux côtés, double, axe Y**  
 25(1")      48-84945
- 

**Porte-outil de tronçonnage, réglable**  
 SH 32      48-99067
- 

**Porte-outil de tronçonnage, réglable, HP-IC**  
 SH 32      48-102264R      IC 80 bar  
 SH 32      48-102264L      IC 80 bar
- 

**Porte-outil combiné, universel, double, axe Y**  
 Ø 40      48-84946
- 

**Porte-outil combiné, deux côtés, double, axe Y**  
 Ø 32      48-84948

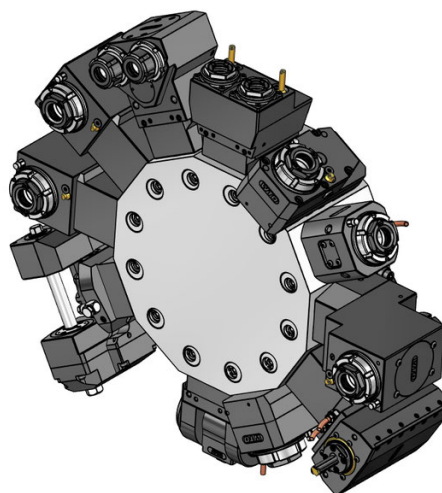
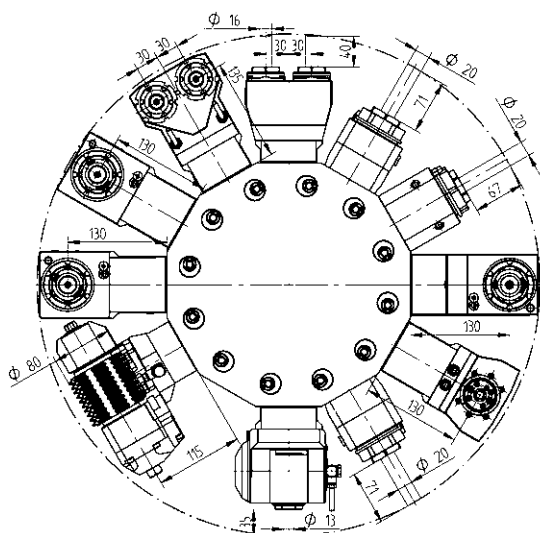

Porte-outils entrainés - QuickFlex®

- 

**Porte-outil d'alésage et de fraisage droit**  
**ER-32 QF** 420132018-40 1:1 EC  
 0067732000  
**ER-32 QF** 420132019-40 1:1 IC 80 bar  
 0067732000
- 

**Porte-outil d'alésage et de fraisage droit décalé**  
**ER-32 QF** 420132020-40 1:1 EC  
 0067732000  
**ER-32 QF** 420132021-40 1:1 IC 80 bar  
 0067732000
- 

**Porte-outil d'alésage et de fraisage à renvoi d'angle**  
**ER-32 QF** 420532049-40 1:1 EC  
 0067732000  
**ER-32 QF** 420532050-40 1:1 IC 80 bar  
 0067732000
- 

**Porte-outil d'alésage et de fraisage à renvoi d'angle, broche de reprise**  
**ER-32 QF** 420532051-40 1:1 EC  
 0067732000  
**ER-32 QF** 420532052-40 1:1 IC 80 bar  
 0067732000
- 

**Porte-outil d'alésage et de fraisage à renvoi d'angle, deux côtés**  
**ER-32 QF** 420532053-40 1:1 EC  
 0067732000

Porte-outils entrainés - Programme élargi

- 

**Porte-outil d'alésage et de fraisage droit décalé**  
**ER-25 QF** 420125018-40 1:2 EC  
 0067725001  
**ER-25 QF** 420125019-40 1:2 IC 80 bar  
 0067725001
- 

**Porte-outil d'alésage et de fraisage droit décalé, deux côtés**  
**ER-32 QF** 423002012-40 1:1 EC  
 0067732000  
**ER-32 QF** 423002013-40 1:1 IC 80 bar  
 0067732000
- 

**Porte-outil d'alésage et de fraisage à renvoi d'angle**  
**ER-25 QF** 420525028-40 1:2 EC  
 0067725001  
**ER-25 QF** 420525029-40 1:2 IC 80 bar  
 0067725001  
**ER-32 QF** 420532054-40 2:1 EC  
 0067732000  
**ER-32 QF** 420532055-40 2:1 IC 80 bar  
 0067732000

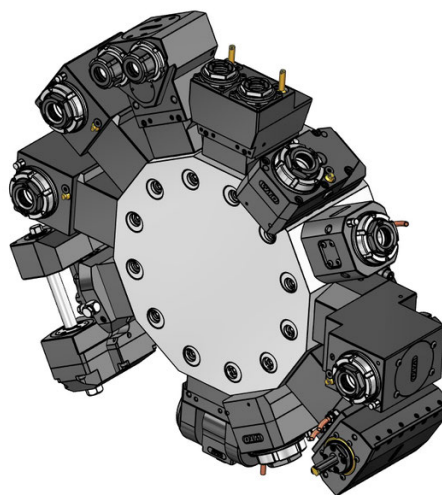
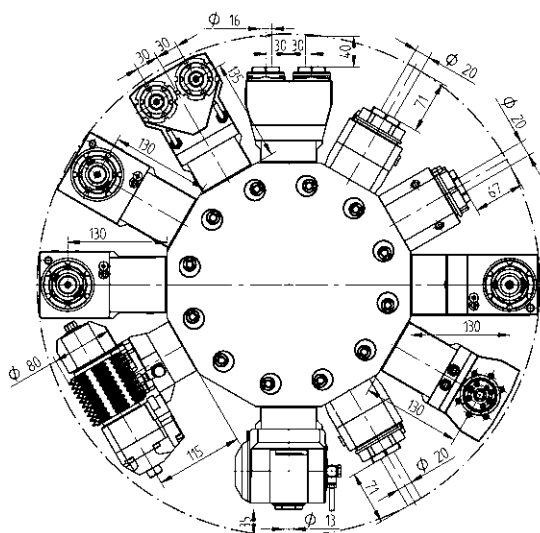

Porte-outils entraînés - Programme élargi



**Porte-outil d'alésage et de fraisage à angle réglable**

<b>ER 20</b>	411013012-40	1:1	EC
	00675000928		
<b>ER 20</b>	411013025-40	1:1	IC 80 bar
	00675000928		
<b>ER 16</b>	411010016-40	1:2	EC
	00675000936		
<b>ER 16</b>	411010017-40	1:2	IC 80 bar
	00675000936		



**Unité de taillage de dentures**

<b>Type 16-1</b>	411500042-40	1:1	EC
	00675000926		
	160016161 Ø 16		
	160022161 Ø 22		
	160027161 Ø 27		
	160015161 Ø 5/8"		
	160019161 Ø 3/4"		
	160025161 Ø 1"		
	160031161 Ø 1 1/4"		
	110587		
<b>Type 16-1</b>	411500032-40	2:1	EC
	00675000926		
	160016161 Ø 16		
	160022161 Ø 22		
	160027161 Ø 27		
	160015161 Ø 5/8"		
	160019161 Ø 3/4"		
	160025161 Ø 1"		
	160031161 Ø 1 1/4"		
	110587		

Porte-outils entraînés - Programme élargi



**Porte-outil d'alésage et de fraisage droit, double, axe Y**

<b>ER 25</b>	413002024-40	1:1,5	EC
	00675000930		
<b>ER 25</b>	413002025-40	1:1,5	IC 80 bar
	00675000930		

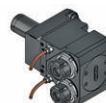

**Porte-outil d'alésage et de fraisage à renvoi d'angle double, axe Y**

<b>ER 25</b>	413502014-40	1:1	EC
	00675000915		
<b>ER 25</b>	413502015-40	1:1	IC 80 bar
	00675000915		

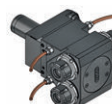

**Porte-outil d'alésage et de fraisage à renvoi d'angle double, deux côtés, axe Y**

<b>ER 25</b>	413502019-40	1:1	EC
	00675000915		

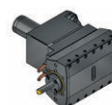

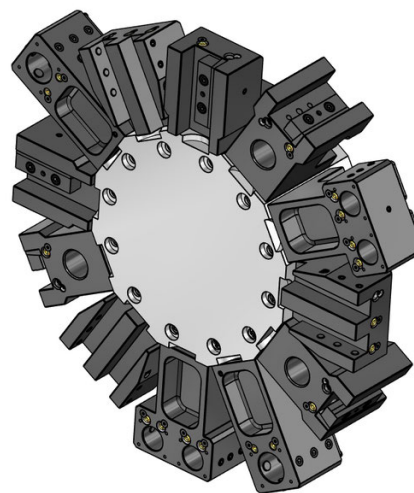
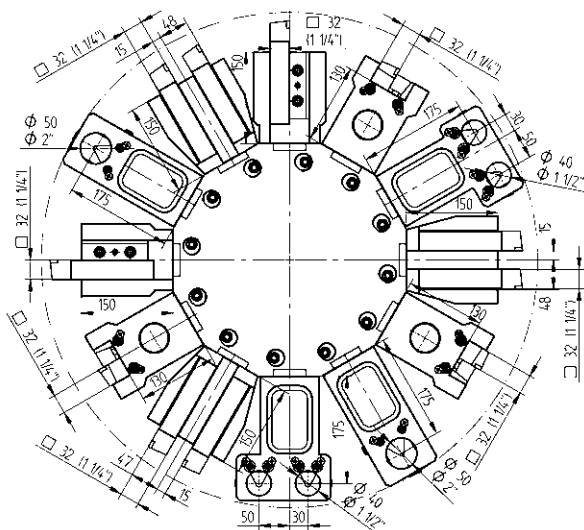

**Unité de brochage intérieur et extérieur**

<b>TN765050</b>	414532008-40	1:1	EC
-----------------	--------------	-----	----



Porte-outils fixes - Programme standard

- 

**Porte-outil radial**  
32 48-81921
- 

**Porte-outil radial, HP-IC**  
25 48-109222-HP IC 80 bar
- 

**Porte-outil axial**  
32 48-81923
- 

**Porte-outil combiné, universel**  
Ø 50 48-81924

Porte-outils fixes - Programme élargi

- 

**Porte-outil radial, double, axe Y**  
32 (1 1/4") 48-85286
- 

**Porte-outil radial, double, axe Y, broche de reprise**  
32 (1 1/4") 48-95077
- 

**Porte-outil de tronçonnage, réglable**  
SH 32 48-100356
- 

**Porte-outil de tronçonnage, réglable, long, HP-IC**  
SH 32 48-100318R IC 80 bar  
343-810100R30  
SH 32 48-100318L IC 80 bar  
343-810100L30
- 

**Porte-outil combiné, universel, double, axe Y**  
Ø 40 48-85287  
241140020 ER32  
241140026 ER40
- 

**Porte-barre d'alésage, avec fente**  
Ø 50 48-110846
- 

**Porte-barre d'alésage, ébauche**  
48-99905

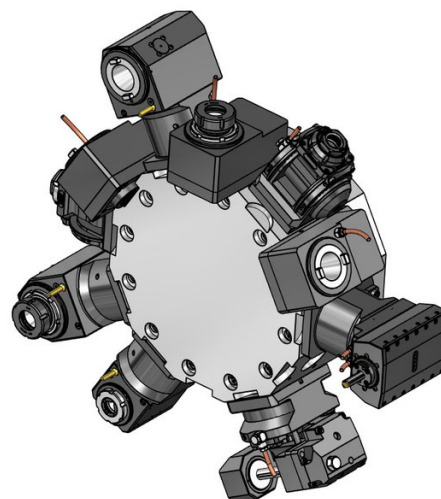
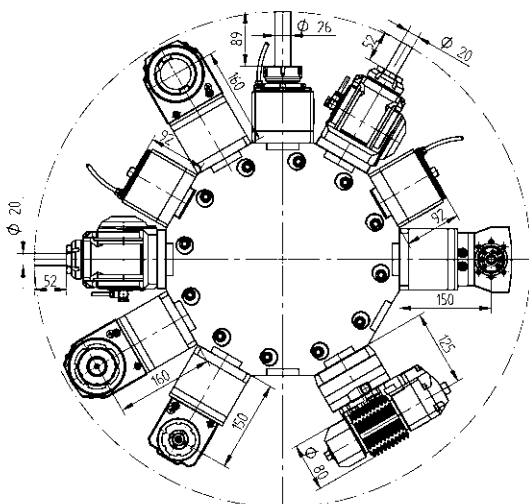

Porte-outils entrainés - Performance Line



**Porte-outil d'alésage et de fraisage droit décalé**

- ER 40 410126070-50 1:1 EC  
00675000941
- ER 40 410126071-50 1:1 IC 80 bar  
00675000941



**Porte-outil d'alésage et de fraisage droit décalé cône ISO/BT/CAT 40**

410140001-50 1:1 EC



**Porte-outil d'alésage et de fraisage à renvoi d'angle**

- ER 40 410526078-50 1:1 EC  
00675000744
- ER 40 410526063-50 1:1 IC 80 bar  
00675000744



**Porte-outil d'alésage et de fraisage à renvoi d'angle cône ISO/BT/CAT 40**

410540001-50 1:1 EC



**Porte-outil d'alésage et de fraisage à renvoi d'angle, broche de reprise**

- ER 40 410526091-50 1:1 EC  
00675000744
- ER 40 410526092-50 1:1 IC 80 bar  
00675000744

Porte-outils entrainés - Programme élargi



**Porte-outil d'alésage et de fraisage droit décalé**

- ER 25 410116038-50 1:2 EC  
00675000720
- ER 25 410116037-50 1:2 IC 80 bar  
00675000720



**Porte-outil d'alésage et de fraisage à renvoi d'angle**

- ER 40 410526074-50 2:1 EC  
00675000744
- ER 40 410526082-50 2:1 IC 80 bar  
00675000744



**Porte-outil d'alésage et de fraisage à angle réglable**

- ER-32 QF 421032010-50 1:1 EC  
00675000976
- ER-32 QF 421032011-50 1:1 IC 80 bar  
00675000976



**Porte-outil d'alésage et de fraisage à angle réglable, long**

- ER-32 QF 421032012-50 1:1 EC  
00675000976
- ER-32 QF 421032013-50 1:1 IC 80 bar  
00675000976

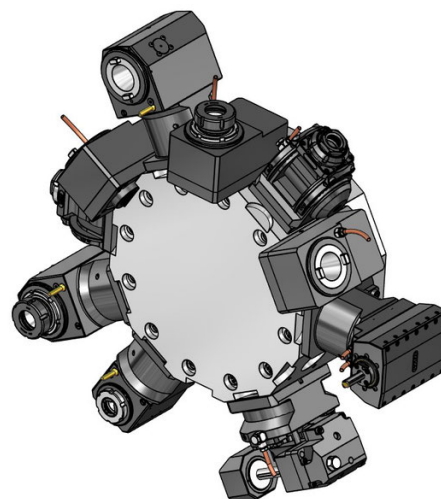
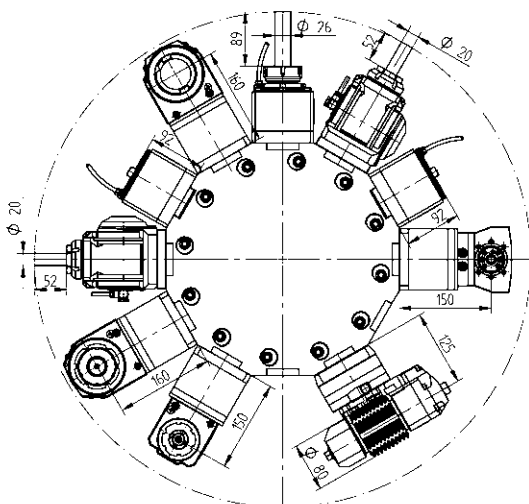

Porte-outils entrainés - Programme élargi



**Porte-outil de fraisage décalé pour fraise disque**

Type 19-2 411500012-50 3:1 EC

- 00675000259
- 160022192 Ø 22
- 160027192 Ø 27
- 160032192 Ø 32
- 160040192 Ø 40
- 160023192 Ø 7/8"
- 160025192 Ø 1"
- 160031192 Ø 1 1/4"
- 160038192 Ø 1 1/2"

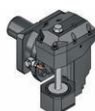

**Unité de taillage de dentures**

Type 16-1 411500017-50 1:1 EC

- 00675000954
- 160016161 Ø 16
- 160022161 Ø 22
- 160027161 Ø 27
- 160015161 Ø 5/8"
- 160019161 Ø 3/4"
- 160025161 Ø 1"
- 160031161 Ø 1 1/4"
- 110587



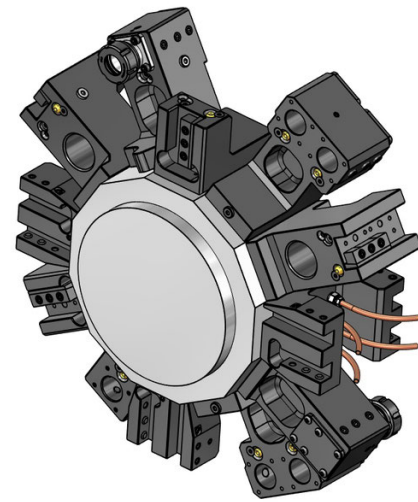
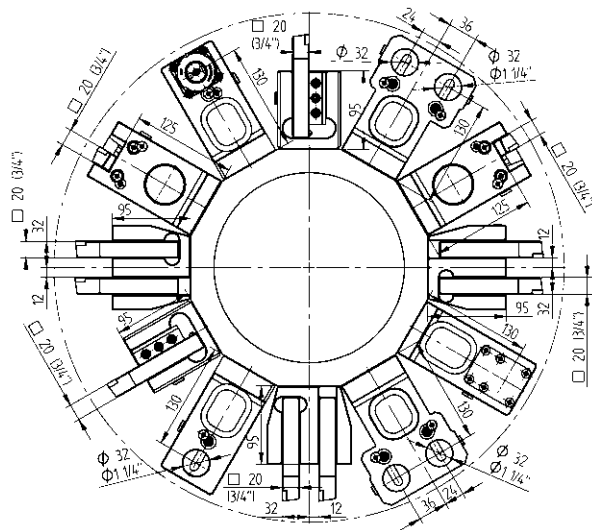

**Unité de brochage intérieur et extérieur**

TN765050 414532002-50 1:1 EC





Porte-outils fixes - Programme standard

- 

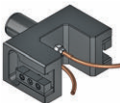
**Porte-outil radial, HP-IC**  
 20 48-82534-HP IC 80 bar
- 

**Porte-outil radial, HP-IC**  
 20 48-82536-HP IC 80 bar
- 

**Porte-outil radial, deux côtés**  
 20 48-89297
- 

**Porte-outil radial, deux côtés, HP-IC**  
 20 48-89297-HP IC 80 bar
- 

**Porte-outil axial**  
 20 48-84005
- 

**Porte-outil combiné, universel**  
 Ø 32 48-81929  
 241132016 ER25  
 241132020 ER32  
 Ø 40 48-111846  
 241140020 ER32  
 241140026 ER40
- 

**Porte-outil combiné**  
 Ø 32 48-82787  
 241132016 ER25  
 241132020 ER32

Porte-outils fixes - Programme standard

- 

**Porte-pince**  
 ER 32 48-83071  
 107532000
- 

**Porte-pince**  
 ER 32 48-83072  
 107532000

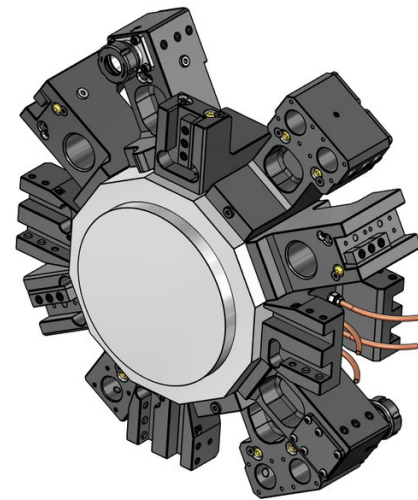
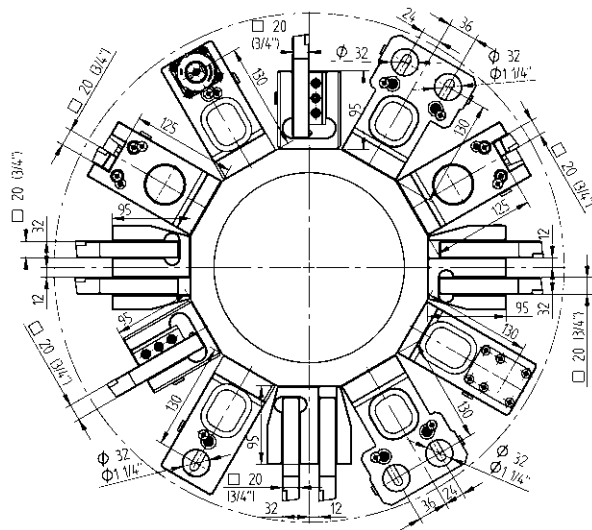

Porte-outils fixes - Programme élargi



**Porte-outil radial, double, axe Y**

20 (3/4") 48-88028

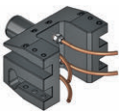

**Porte-outil radial, deux côtés, double, axe Y**

20 (3/4") 48-87850



**Porte-outil de tronçonnage, réglable**

SH 32 48-99061



**Porte-outil de tronçonnage, réglable, HP-IC**

SH 32 48-99650R IC 80 bar  
343-810100R17

SH 32 48-99650L IC 80 bar  
343-810100L17

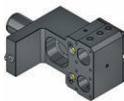

**Porte-outil combiné, universel, double, axe Y**

Ø 32 48-87853

 241132016 ER25

 241132020 ER32



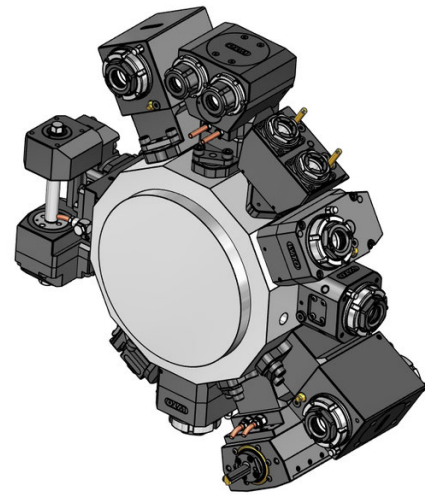
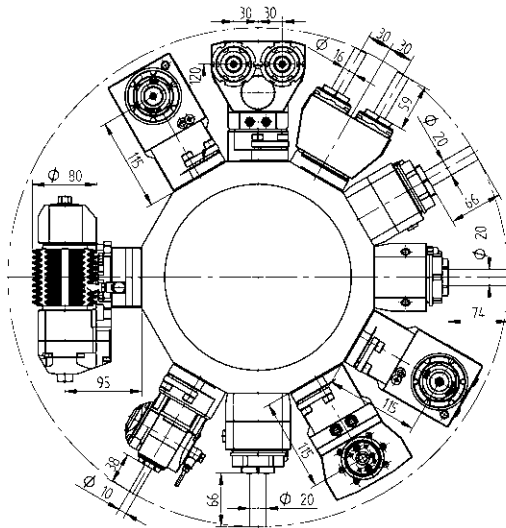

Porte-outils entraînés - QuickFlex®

- 

**Porte-outil d'alésage et de fraisage droit décalé**  
**ER-32 QF** 420132030-40 1:1 EC  
 0067732000  
**ER-32 QF** 420132031-40 1:1 IC 80 bar  
 0067732000
- 

**Porte-outil d'alésage et de fraisage droit décalé**  
**ER-32 QF** 420132034-40 1:1 EC  
 0067732000  
**ER-32 QF** 420132035-40 1:1 IC 80 bar  
 0067732000
- 

**Porte-outil d'alésage et de fraisage à renvoi d'angle**  
**ER-32 QF** 420532071-40 1:1 EC  
 0067732000  
**ER-32 QF** 420532072-40 1:1 IC 80 bar  
 0067732000
- 

**Porte-outil d'alésage et de fraisage à renvoi d'angle**  
**ER-32 QF** 420532073-40 1:1 EC  
 0067732000  
**ER-32 QF** 420532074-40 1:1 IC 80 bar  
 0067732000
- 

**Porte-outil d'alésage et de fraisage à renvoi d'angle, deux côtés**  
**ER-32 QF** 420532075-40 1:1 EC  
 0067732000

Porte-outils entraînés - Programme élargi

- 

**Porte-outil d'alésage et de fraisage droit**  
**ER-32 QF** 420132038-40 1:1 EC  
 0067732000  
**ER-32 QF** 420132039-40 1:1 IC 80 bar  
 0067732000
- 

**Porte-outil d'alésage et de fraisage droit décalé**  
**ER-25 QF** 420125016-40 1:2 EC  
 0067725001  
**ER-25 QF** 420125017-40 1:2 IC 80 bar  
 0067725001  
**ER-32 QF** 420132052-40 2:1 EC  
 0067732000  
**ER-32 QF** 420132053-40 2:1 IC 80 bar  
 0067732000
- 

**Porte-outil d'alésage et de fraisage droit décalé**  
**ER-25 QF** 420125040-40 1:2 EC  
 0067725001  
**ER-25 QF** 420125041-40 1:2 IC 80 bar  
 0067725001
- 

**Porte-outil d'alésage et de fraisage droit décalé, deux côtés**  
**ER-32 QF** 423002010-40 1:1 EC  
 0067732000  
**ER-32 QF** 423002011-40 1:1 IC 80 bar  
 0067732000

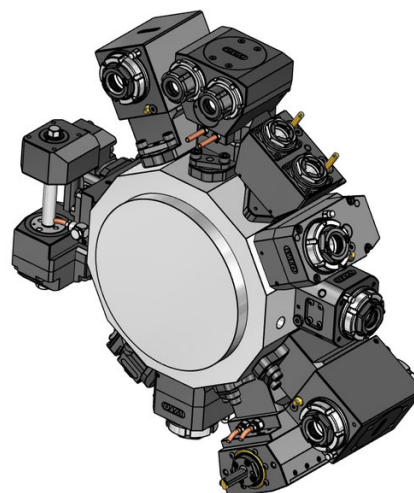
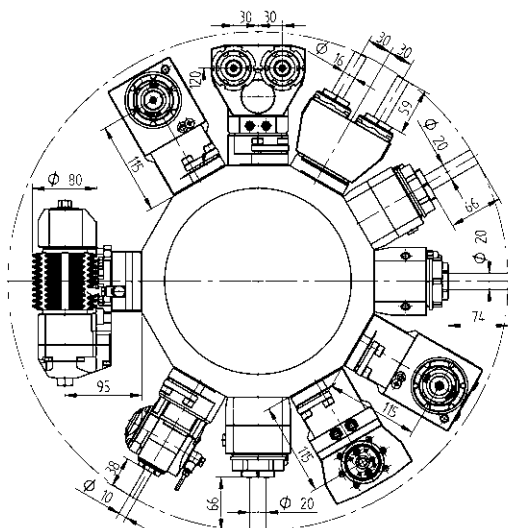

Porte-outils entraînés - Programme élargi



**Porte-outil d'alésage et de fraisage à renvoi d'angle**

<b>ER-25 QF</b>	420525034-40	1:2	EC
	0067725001		
<b>ER-25 QF</b>	420525035-40	1:2	IC 80 bar
	0067725001		
<b>ER-32 QF</b>	420532089-40	2:1	EC
	0067732000		
<b>ER-32 QF</b>	420532090-40	2:1	IC 80 bar
	0067732000		



**Porte-outil d'alésage et de fraisage à angle réglable**

<b>ER 16</b>	411010010-40	1:1	EC
	00675000902		
<b>ER 16</b>	411010011-40	1:1	IC 80 bar
	00675000902		
<b>ER 11</b>	411007003-40	1:2	EC
	00675000914		
<b>ER 11</b>	411007004-40	1:2	IC 80 bar
	00675000914		



**Unité de taillage de dentures**

<b>Type 16-1</b>	411500028-40	2:1	EC
	00675000926		
	160016161 Ø 16		
	160022161 Ø 22		
	160027161 Ø 27		
	160015161 Ø 5/8"		
	160019161 Ø 3/4"		
	160025161 Ø 1"		
	160031161 Ø 1 1/4"		
	110587		

Porte-outils entraînés - Programme élargi

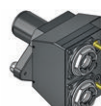

**Porte-outil d'alésage et de fraisage droit, double, axe Y**

<b>ER 25</b>	413002022-40	1:1,5	EC
	00675000930		
<b>ER 25</b>	413002023-40	1:1,5	IC 80 bar
	00675000930		



**Porte-outil d'alésage et de fraisage à renvoi d'angle double, axe Y**

<b>ER 25</b>	413502012-40	1:1	EC
	00675000915		
<b>ER 25</b>	413502013-40	1:1	IC 80 bar
	00675000915		



**Unité de brochage intérieur et extérieur**

<b>TN765050</b>	414532010-40	1:1	EC
-----------------	--------------	-----	----

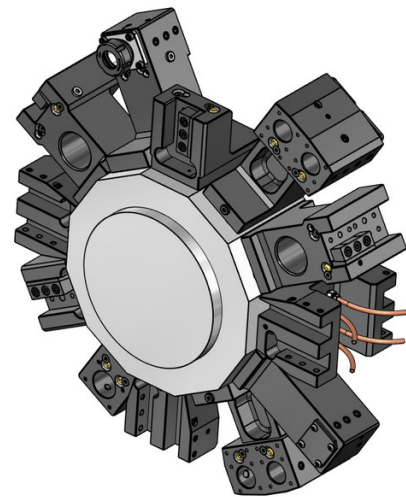
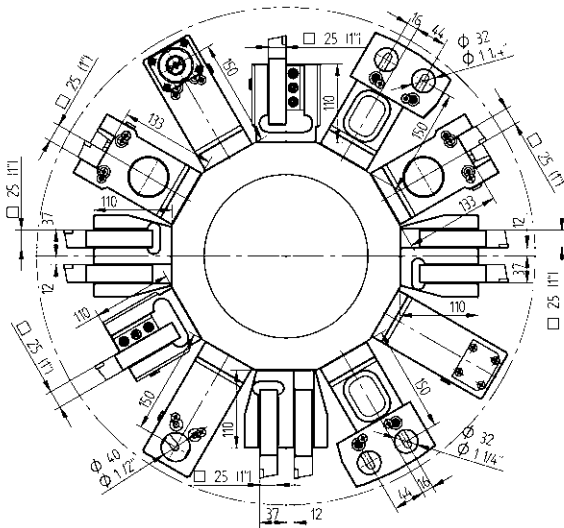

Porte-outils fixes - Programme standard

Porte-outils fixes - Programme standard



**Porte-outil radial, HP-IC**  
 25 48-81926-HP IC 80 bar



**Porte-pince**  
 ER 32 48-82988  
 107532000



**Porte-outil radial, HP-IC**  
 25 48-82545-HP IC 80 bar



**Porte-outil radial, deux côtés, HP-IC**  
 25 48-89299-HP IC 80 bar



**Porte-outil axial**  
 25 48-84006



**Porte-outil combiné**  
 Ø 40 48-81930  
 241140020 ER32



**Porte-outil combiné**  
 Ø 40 48-82783  
 241140020 ER32



**Porte-outil combiné, deux côtés**  
 Ø 40 48-106919



**Porte-pince**  
 ER 32 48-82986  
 107532000

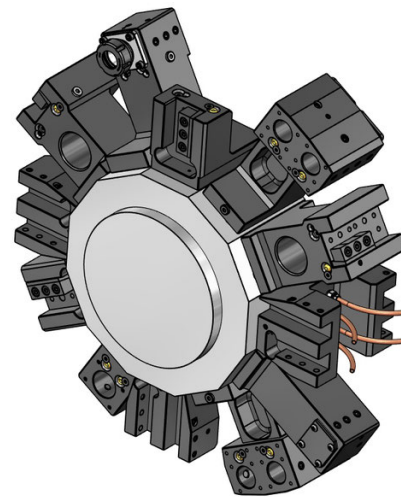
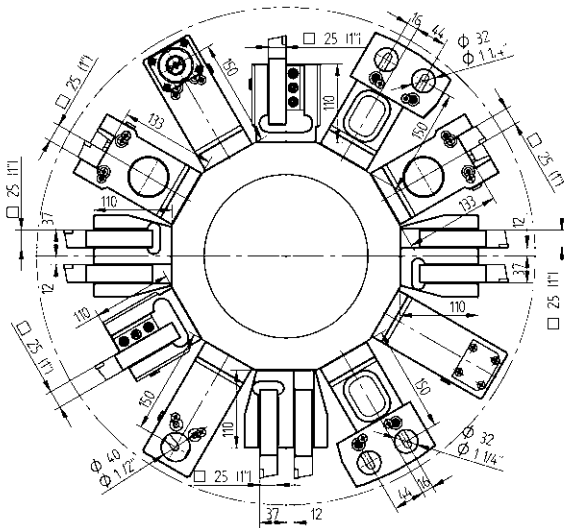

Porte-outils fixes - Programme élargi



**Porte-outil radial, double, axe Y**

25(1") 48-88032

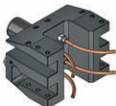

**Porte-outil radial, deux côtés, double, axe Y**

25(1") 48-87706



**Porte-outil de tronçonnage, réglable**

SH 32 48-99062



**Porte-outil de tronçonnage, réglable, HP-IC**

SH 32 48-102266R IC 80 bar

SH 32 48-102266L IC 80 bar



**Porte-outil de tronçonnage, réglable**

SH 32 48-116443



**Porte-outil de tronçonnage, réglable, HP-IC**

SH 32 48-116441R IC 80 bar

343-810100R106

SH 32 48-116441L IC 80 bar

343-810100L106



**Porte-outil combiné, deux côtés, double, axe Y**

Ø 32 48-87698

 241132020 ER32

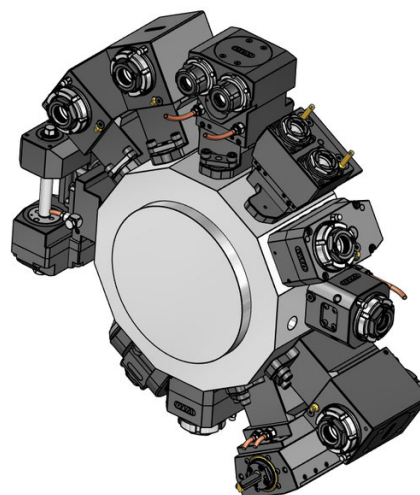
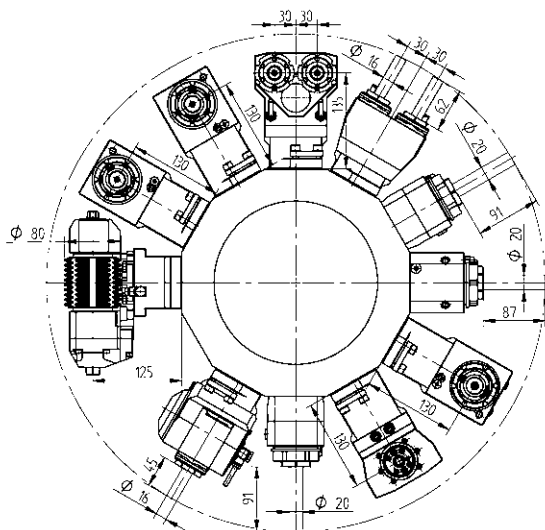

Porte-outils entrainés - QuickFlex®

Porte-outils entrainés - Programme élargi



**Porte-outil d'alésage et de fraisage droit décalé**

- ER-32 QF 420132032-40 1:1 EC  
0067732000
- ER-32 QF 420132033-40 1:1 IC 80 bar  
0067732000



**Porte-outil d'alésage et de fraisage droit décalé**

- ER-32 QF 420132036-40 1:1 EC  
0067732000
- ER-32 QF 420132037-40 1:1 IC 80 bar  
0067732000



**Porte-outil d'alésage et de fraisage à renvoi d'angle**

- ER-32 QF 420532076-40 1:1 EC  
0067732000
- ER-32 QF 420532077-40 1:1 IC 80 bar  
0067732000



**Porte-outil d'alésage et de fraisage à renvoi d'angle**

- ER-32 QF 420532078-40 1:1 EC  
0067732000
- ER-32 QF 420532079-40 1:1 IC 80 bar  
0067732000



**Porte-outil d'alésage et de fraisage à renvoi d'angle, deux côtés**

- ER-32 QF 420532156-40 1:1 EC  
0067732000



**Porte-outil d'alésage et de fraisage droit**

- ER-32 QF 420132042-40 1:1 EC  
0067732000
- ER-32 QF 420132043-40 1:1 IC 80 bar  
0067732000



**Porte-outil d'alésage et de fraisage droit décalé**

- ER-25 QF 420125022-40 1:2 EC  
0067725001
- ER-25 QF 420125023-40 1:2 IC 80 bar  
0067725001
- ER-32 QF 420132050-40 2:1 EC  
0067732000
- ER-32 QF 420132051-40 2:1 IC 80 bar  
0067732000



**Porte-outil d'alésage et de fraisage droit décalé**

- ER-25 QF 420125054-40 1:2 EC  
0067725001
- ER-25 QF 420125055-40 1:2 IC 80 bar  
0067725001
- ER-32 QF 420132111-40 2:1 EC  
0067732000
- ER-32 QF 420132112-40 2:1 IC 80 bar  
0067732000



**Porte-outil d'alésage et de fraisage droit décalé, deux côtés**

- ER-32 QF 423002016-40 1:1 EC  
0067732000
- ER-32 QF 423002017-40 1:1 IC 80 bar  
0067732000

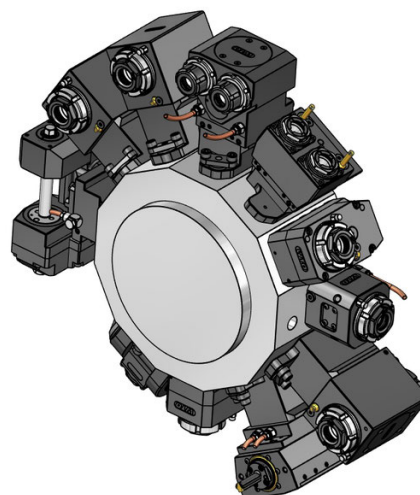
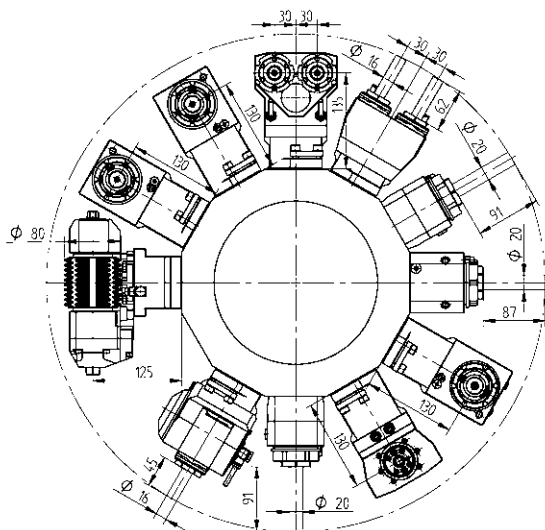

Porte-outils entraînés - Programme élargi



**Porte-outil d'alésage et de fraisage à renvoi d'angle**

<b>ER-25 QF</b>	420525032-40	1:2	EC
	0067725001		
<b>ER-25 QF</b>	420525033-40	1:2	IC 80 bar
	0067725001		
<b>ER-32 QF</b>	420532087-40	2:1	EC
	0067732000		
<b>ER-32 QF</b>	420532088-40	2:1	IC 80 bar
	0067732000		



**Porte-outil d'alésage et de fraisage à angle réglable**

<b>ER 25</b>	411016005-40	1:1	EC
	00675000934		
<b>ER 25</b>	411016023-40	1:1	IC 80 bar
	00675000934		
<b>ER 16</b>	411010014-40	1:2	EC
	00675000936		
<b>ER 16</b>	411010015-40	1:2	IC 80 bar
	00675000936		

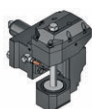

**Unité de taillage de dentures**

<b>Type 16-1</b>	411500030-40	2:1	EC
	00675000954		
	160016161 Ø 16		
	160022161 Ø 22		
	160027161 Ø 27		
	160015161 Ø 5/8"		
	160019161 Ø 3/4"		
	160025161 Ø 1"		
	160031161 Ø 1 1/4"		
	110587		

Porte-outils entraînés - Programme élargi

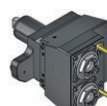

**Porte-outil d'alésage et de fraisage droit, double, axe Y**

<b>ER 25</b>	413002026-40	1:1,5	EC
	00675000930		
<b>ER 25</b>	413002027-40	1:1,5	IC 80 bar
	00675000930		



**Porte-outil d'alésage et de fraisage à renvoi d'angle double, axe Y**

<b>ER 25</b>	413502016-40	1:1	EC
	00675000915		
<b>ER 25</b>	413502017-40	1:1	IC 80 bar
	00675000915		



**Porte-outil d'alésage et de fraisage à renvoi d'angle double, deux côtés, axe Y**

<b>ER 25</b>	413502023-40	1:1	EC
	00675000915		



**Unité de brochage intérieur et extérieur**

<b>TN765050</b>	414532011-40	1:1	EC
-----------------	--------------	-----	----



**Unité de brochage intérieur et extérieur**

<b>TN765050</b>	414532014-40	1:1	EC
-----------------	--------------	-----	----

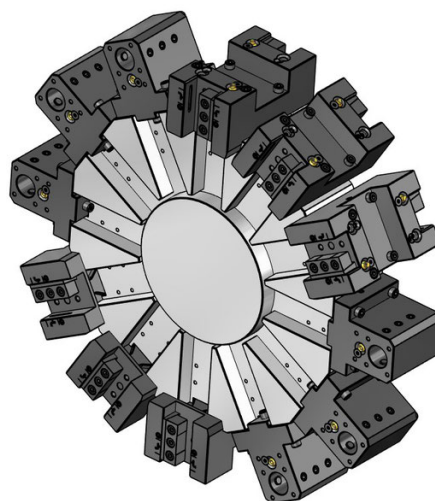
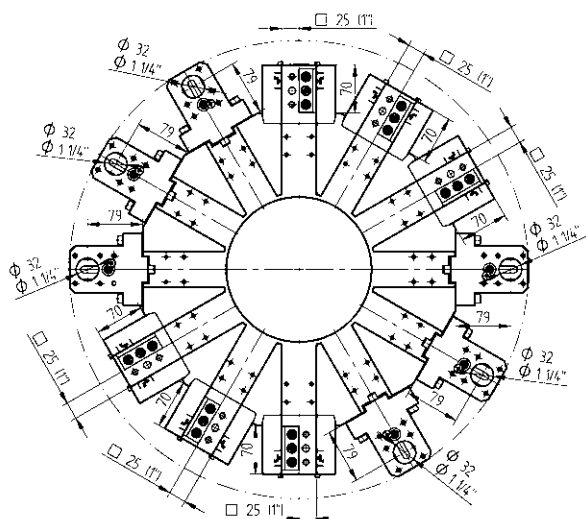

Porte-outils fixes - Programme standard

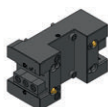

**Porte-outil radial, deux côtés, HP-IC**

**25**      48-116172-HP      IC 80 bar



**Porte-outil combiné**

**Ø 32**      48-116173      IC 80 bar

 241132016 ER25

 241132020 ER32

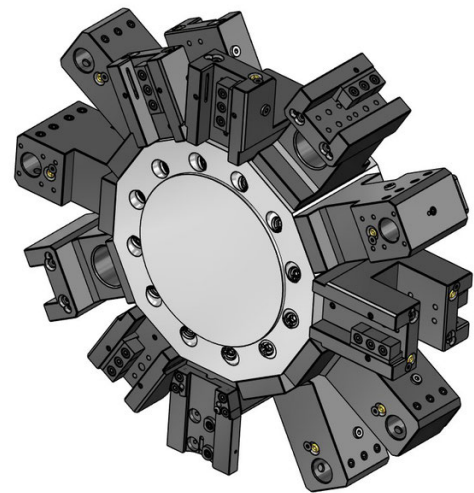
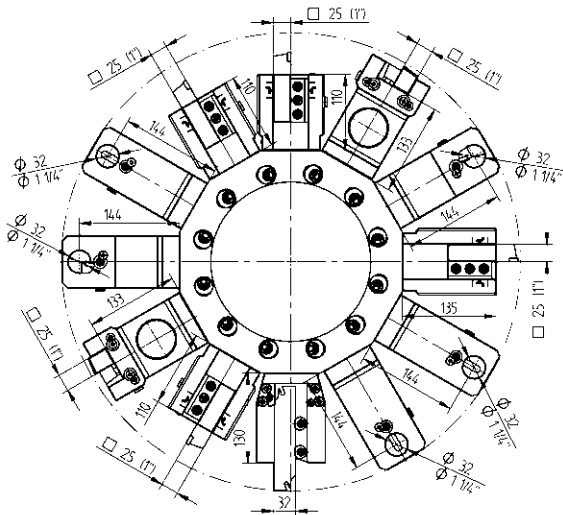



Porte-outils fixes - Programme standard



- 

**Porte-outil radial, HP-IC**  
**25**      48-81926-HP      IC 80 bar
- 

**Porte-outil radial, HP-IC**  
**25**      48-82545-HP      IC 80 bar
- 

**Porte-outil radial, deux côtés, HP-IC**  
**25**      48-116404-HP      IC 80 bar
- 

**Porte-outil axial**  
**25**      48-84006
- 

**Porte-outil combiné**  
**Ø 32**      48-115977  
 241132016 ER25  
 241132020 ER32
- 

**Porte-outil combiné, deux côtés**  
**Ø 32**      48-115979

Porte-outils fixes - Programme élargi

- 

**Porte-outil de tronçonnage, réglable**  
**SH 32**      48-99062
- 

**Porte-outil de tronçonnage, réglable, HP-IC**  
**SH 32**      48-102266R      IC 80 bar  
**SH 32**      48-102266L      IC 80 bar
- 

**Porte-outil de tronçonnage, réglable**  
**SH 32**      48-116443
- 

**Porte-outil de tronçonnage, réglable, HP-IC**  
**SH 32**      48-116441R      IC 80 bar  
                  343-810100R106  
**SH 32**      48-116441L      IC 80 bar  
                  343-810100L106



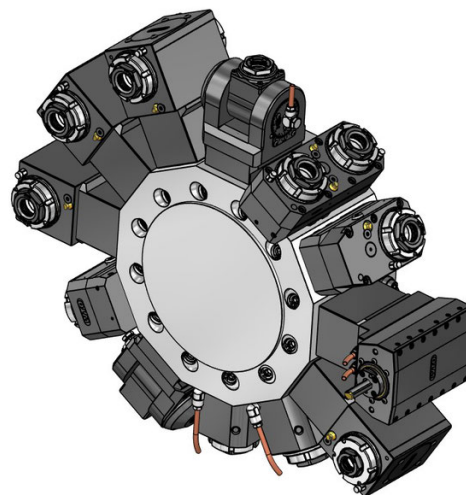
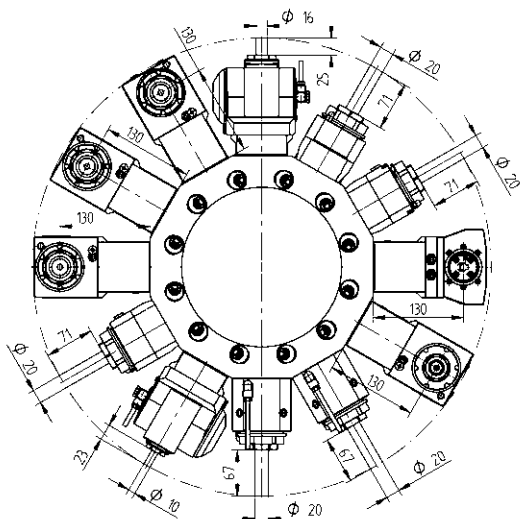

Porte-outils entrainés - QuickFlex®



**Porte-outil d'alésage et de fraisage droit**

- ER-32 QF 420132042-40 1:1 EC  
0067732000
- ER-32 QF 420132043-40 1:1 IC 80 bar  
0067732000



**Porte-outil d'alésage et de fraisage droit décalé**

- ER-32 QF 420132032-40 1:1 EC  
0067732000
- ER-32 QF 420132033-40 1:1 IC 80 bar  
0067732000



**Porte-outil d'alésage et de fraisage droit décalé**

- ER-32 QF 420132036-40 1:1 EC  
0067732000
- ER-32 QF 420132037-40 1:1 IC 80 bar  
0067732000



**Porte-outil d'alésage et de fraisage à renvoi d'angle**

- ER-32 QF 420532076-40 1:1 EC  
0067732000
- ER-32 QF 420532077-40 1:1 IC 80 bar  
0067732000



**Porte-outil d'alésage et de fraisage à renvoi d'angle**

- ER-32 QF 420532078-40 1:1 EC  
0067732000
- ER-32 QF 420532079-40 1:1 IC 80 bar  
0067732000



**Porte-outil d'alésage et de fraisage à renvoi d'angle, deux côtés**

- ER-32 QF 420532156-40 1:1 EC  
0067732000

Porte-outils entrainés - Programme élargi



**Porte-outil d'alésage et de fraisage droit décalé**

- ER-25 QF 420125022-40 1:2 EC  
0067725001
- ER-25 QF 420125023-40 1:2 IC 80 bar  
0067725001

- ER-32 QF 420132050-40 2:1 EC  
0067732000

- ER-32 QF 420132051-40 2:1 IC 80 bar  
0067732000



**Porte-outil d'alésage et de fraisage droit décalé**

- ER-25 QF 420125054-40 1:2 EC  
0067725001
- ER-25 QF 420125055-40 1:2 IC 80 bar  
0067725001

- ER-32 QF 420132111-40 2:1 EC  
0067732000

- ER-32 QF 420132112-40 2:1 IC 80 bar  
0067732000



**Porte-outil d'alésage et de fraisage droit décalé, deux côtés**

- ER-32 QF 423002016-40 1:1 EC  
0067732000
- ER-32 QF 423002017-40 1:1 IC 80 bar  
0067732000

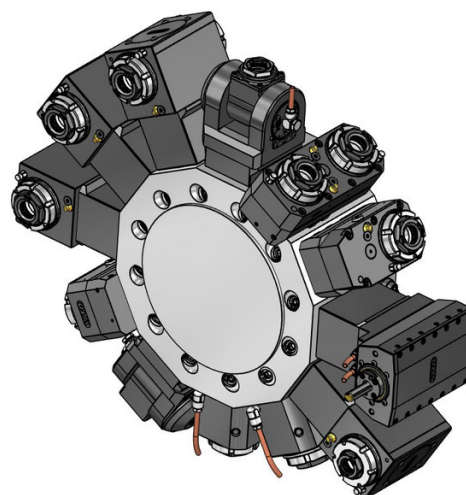
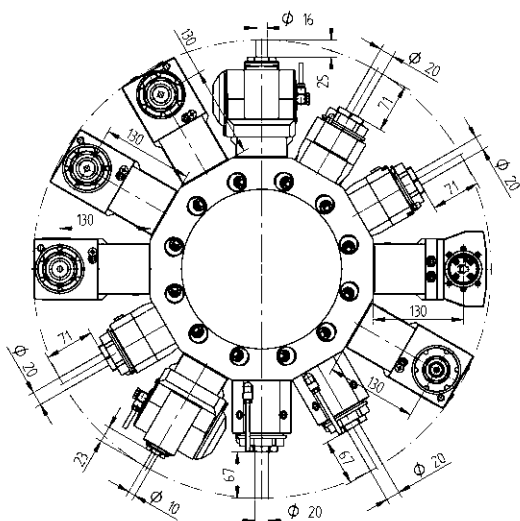

Porte-outils entrainés - Programme élargi

Porte-outils entrainés - Programme élargi



**Porte-outil d'alésage et de fraisage à renvoi d'angle**

<b>ER-25 QF</b>	420525032-40	1:2	EC
	0067725001		
<b>ER-25 QF</b>	420525033-40	1:2	IC 80 bar
	0067725001		
<b>ER-32 QF</b>	420532087-40	2:1	EC
	0067732000		
<b>ER-32 QF</b>	420532088-40	2:1	IC 80 bar
	0067732000		

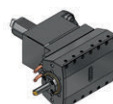

**Unité de brochage intérieur et extérieur**

**TN765050** 414532014-40 1:1 EC



**Porte-outil d'alésage et de fraisage à renvoi d'angle**

<b>ER-25 QF</b>	420525064-40	1:2	EC
	0067725001		
<b>ER-25 QF</b>	420525065-40	1:2	IC 80 bar
	0067725001		
<b>ER-32 QF</b>	420532161-40	2:1	EC
	0067732000		
<b>ER-32 QF</b>	420532162-40	2:1	IC 80 bar
	0067732000		



**Porte-outil d'alésage et de fraisage à angle réglable**

<b>ER 25</b>	411016005-40	1:1	EC
	00675000934		
<b>ER 25</b>	411016023-40	1:1	IC 80 bar
	00675000934		
<b>ER 16</b>	411010014-40	1:2	EC
	00675000936		
<b>ER 16</b>	411010015-40	1:2	IC 80 bar
	00675000936		



**Unité de brochage intérieur et extérieur**

**TN765050** 414532011-40 1:1 EC

Douilles de réduction standard - cylindriques

Douilles de réduction standard - cône morse



**Douille de réduction Ø 20**

240020006	ø 6
240020008	ø 8
240020010	ø 10
240020012	ø 12
240020014	ø 14
240020016	ø 16



**Douille de réduction Ø 32**

240032006	ø 6
240032008	ø 8
240032010	ø 10
240032012	ø 12
240032014	ø 14
240032016	ø 16
240032018	ø 18
240032020	ø 20
240032025	ø 25



**Douille de réduction Ø 40**

240040006	ø 6
240040008	ø 8
240040010	ø 10
240040012	ø 12
240040014	ø 14
240040016	ø 16
240040020	ø 20
240040025	ø 25
240040032	ø 32



**Douille de réduction Ø 50**

240050010	ø 10
240050012	ø 12
240050016	ø 16
240050020	ø 20
240050025	ø 25
240050032	ø 32
240050040	ø 40



**Douille de réduction Ø 32**

240532001	CM 1
240532002	CM 2
240532003	CM 3



**Douille de réduction Ø 40**

240540001	CM 1
240540002	CM 2
240540003	CM 3
240540004	CM 4

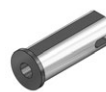

**Douille de réduction Ø 50**

240550002	CM 2
240550003	CM 3
240550004	CM 4

Pinces DIN 6499B (ER/ESX)



**ER 11**

190011000	∅ 7-0.5	∅ 0.276-0.020
190011010	∅ 1-0.5	∅ 0.039-0.020
190011015	∅ 1.5-1	∅ 0.059-0.039
190011020	∅ 2-1.5	∅ 0.079-0.059
190011025	∅ 2.5-2	∅ 0.098-0.079
190011030	∅ 3-2.5	∅ 0.118-0.098
190011035	∅ 3.5-3	∅ 0.138-0.118
190011040	∅ 4-3.5	∅ 0.158-0.138
190011045	∅ 4.5-4	∅ 0.177-0.158
190011050	∅ 5-4.5	∅ 0.197-0.177
190011055	∅ 5.5-5	∅ 0.217-0.197
190011060	∅ 6-5.5	∅ 0.236-0.217
190011065	∅ 6.5-6	∅ 0.256-0.236
190011070	∅ 7-6.5	∅ 0.276-0.256



**ER 16**

190016000	∅ 10-0.5	∅ 0.394-0.020
190016010	∅ 1-0.5	∅ 0.039-0.020
190016020	∅ 2-1	∅ 0.079-0.039
190016030	∅ 3-2	∅ 0.118-0.079
190016040	∅ 4-3	∅ 0.158-0.118
190016050	∅ 5-4	∅ 0.197-0.158
190016060	∅ 6-5	∅ 0.236-0.197
190016070	∅ 7-6	∅ 0.276-0.236
190016080	∅ 8-7	∅ 0.315-0.276
190016090	∅ 9-8	∅ 0.354-0.315
190016100	∅ 10-9	∅ 0.394-0.354



**ER 20**

190020000	∅ 13-1	∅ 0.512-0.039
190020010	∅ 1-0.5	∅ 0.039-0.020
190020020	∅ 2-1	∅ 0.079-0.039
190020030	∅ 3-2	∅ 0.118-0.079
190020040	∅ 4-3	∅ 0.157-0.118
190020050	∅ 5-4	∅ 0.197-0.157
190020060	∅ 6-5	∅ 0.236-0.197
190020070	∅ 7-6	∅ 0.276-0.236
190020080	∅ 8-7	∅ 0.315-0.276
190020090	∅ 9-8	∅ 0.354-0.315
190020100	∅ 10-9	∅ 0.394-0.354
190020110	∅ 11-10	∅ 0.433-0.394
190020120	∅ 12-11	∅ 0.472-0.433
190020130	∅ 13-12	∅ 0.512-0.472

Pinces DIN 6499B (ER/ESX)



**ER 25**

190025000	∅ 16-1	∅ 0.630-0.039
190025020	∅ 2-1	∅ 0.079-0.039
190025030	∅ 3-2	∅ 0.118-0.079
190025040	∅ 4-3	∅ 0.157-0.118
190025050	∅ 5-4	∅ 0.197-0.157
190025060	∅ 6-5	∅ 0.236-0.197
190025070	∅ 7-6	∅ 0.276-0.236
190025080	∅ 8-7	∅ 0.315-0.276
190025090	∅ 9-8	∅ 0.354-0.315
190025100	∅ 10-9	∅ 0.394-0.354
190025110	∅ 11-10	∅ 0.433-0.394
190025120	∅ 12-11	∅ 0.472-0.433
190025130	∅ 13-12	∅ 0.512-0.472
190025140	∅ 14-13	∅ 0.551-0.512
190025150	∅ 15-14	∅ 0.591-0.551
190025160	∅ 16-15	∅ 0.630-0.591



**ER 32**

190032000	∅ 20-2	∅ 0.787-0.079
190032030	∅ 3-2	∅ 0.118-0.079
190032040	∅ 4-3	∅ 0.157-0.118
190032050	∅ 5-4	∅ 0.197-0.157
190032060	∅ 6-5	∅ 0.236-0.197
190032070	∅ 7-6	∅ 0.276-0.236
190032080	∅ 8-7	∅ 0.315-0.276
190032090	∅ 9-8	∅ 0.354-0.315
190032100	∅ 10-9	∅ 0.394-0.354
190032110	∅ 11-10	∅ 0.433-0.394
190032120	∅ 12-11	∅ 0.472-0.433
190032130	∅ 13-12	∅ 0.512-0.472
190032140	∅ 14-13	∅ 0.551-0.512
190032150	∅ 15-14	∅ 0.591-0.551
190032160	∅ 16-15	∅ 0.630-0.591
190032170	∅ 17-16	∅ 0.669-0.630
190032180	∅ 18-17	∅ 0.709-0.669
190032190	∅ 19-18	∅ 0.748-0.709
190032200	∅ 20-19	∅ 0.787-0.748

Pinces DIN 6499B (ER/ESX)



**ER 40**

190040000	ø 26-3	ø 1.024-0.118
190040040	ø 4-3	ø 0.157-0.118
190040050	ø 5-4	ø 0.197-0.157
190040060	ø 6-5	ø 0.236-0.197
190040070	ø 7-6	ø 0.276-0.236
190040080	ø 8-7	ø 0.315-0.276
190040090	ø 9-8	ø 0.354-0.315
190040100	ø 10-9	ø 0.394-0.354
190040110	ø 11-10	ø 0.433-0.394
190040120	ø 12-11	ø 0.472-0.433
190040130	ø 13-12	ø 0.512-0.472
190040140	ø 14-13	ø 0.551-0.512
190040150	ø 15-14	ø 0.591-0.551
190040160	ø 16-15	ø 0.630-0.591
190040170	ø 17-16	ø 0.669-0.630
190040180	ø 18-17	ø 0.709-0.669
190040190	ø 19-18	ø 0.748-0.709
190040200	ø 20-19	ø 0.787-0.748
190040210	ø 21-20	ø 0.827-0.787
190040220	ø 22-21	ø 0.866-0.827
190040230	ø 23-22	ø 0.906-0.866
190040240	ø 24-23	ø 0.945-0.906
190040250	ø 25-24	ø 0.984-0.945
190040260	ø 26-25	ø 1.024-0.984

Pinces DIN 6499D (ER/ESX) - étanches, pour IC



**ER 11**

191011030	ø 3	
191011040	ø 4	
191011050	ø 5	
191011060	ø 6	
191111013-in		ø 0.125
191111019-in		ø 0.188
191111025-in		ø 0.25



**ER 16**

191016000	ø 3-10	
191016030	ø 3	
191016040	ø 4	
191016050	ø 5	
191016060	ø 6	
191016070	ø 7	
191016080	ø 8	
191016090	ø 9	
191016100	ø 10	
191116001		ø 0.125-0.375
191116013-in		ø 0.125
191116019-in		ø 0.188
191116025-in		ø 0.25
191116031-in		ø 0.313
191116038-in		ø 0.375



**ER 20**

191020000	ø 3-12	
191020030	ø 3	
191020040	ø 4	
191020050	ø 5	
191020060	ø 6	
191020070	ø 7	
191020080	ø 8	
191020090	ø 9	
191020100	ø 10	
191020110	ø 11	
191020120	ø 12	
191120001		ø 0.125-0.5
191120013-in		ø 0.125
191120019-in		ø 0.188
191120025-in		ø 0.25
191120031-in		ø 0.313
191120038-in		ø 0.375
191120044-in		ø 0.438
191120050-in		ø 0.5

Pinces DIN 6499D (ER/ESX) - étanches, pour IC



**ER 25**

191025000	ø 4-16	
191025030	ø 3	
191025040	ø 4	
191025050	ø 5	
191025060	ø 6	
191025070	ø 7	
191025080	ø 8	
191025090	ø 9	
191025100	ø 10	
191025110	ø 11	
191025120	ø 12	
191025130	ø 13	
191025140	ø 14	
191025150	ø 15	
191025160	ø 16	
191125001		ø 0.25-0.625
191125025-in		ø 0.25
191125031-in		ø 0.313
191125038-in		ø 0.375
191125044-in		ø 0.438
191125050-in		ø 0.5
191125056-in		ø 0.563
191125063-in		ø 0.625

Pinces DIN 6499D (ER/ESX) - étanches, pour IC



**ER 40**

191040060	ø 6	
191040080	ø 8	
191040100	ø 10	
191040120	ø 12	
191040140	ø 14	
191040160	ø 16	
191040180	ø 18	
191040200	ø 20	
191040220	ø 22	
191040250	ø 25	
191140025-in		ø 0.25
191140031-in		ø 0.313
191140038-in		ø 0.375
191140044-in		ø 0.438
191140050-in		ø 0.5
191140056-in		ø 0.563
191140063-in		ø 0.625
191140069-in		ø 0.688
191140075-in		ø 0.75
191140088-in		ø 0.875
191140100-in		ø 1



**ER 32**

191032000	ø 4-20	
191032030	ø 3	
191032040	ø 4	
191032050	ø 5	
191032060	ø 6	
191032070	ø 7	
191032080	ø 8	
191032090	ø 9	
191032100	ø 10	
191032110	ø 11	
191032120	ø 12	
191032130	ø 13	
191032140	ø 14	
191032150	ø 15	
191032160	ø 16	
191032170	ø 17	
191032180	ø 18	
191032190	ø 19	
191032200	ø 20	
191132001		ø 0.25-0.75
191132025-in		ø 0.25
191132031-in		ø 0.313
191132038-in		ø 0.375
191132044-in		ø 0.438
191132050-in		ø 0.5
191132056-in		ø 0.563
191132063-in		ø 0.625
191132069-in		ø 0.688
191132075-in		ø 0.75



## Qualité sans compromis.

Chaque étape de production aspire à la plus grande perfection.

Lors de la production de nos porte-outils de précision, de la conception à la fabrication du produit fini, nous ne faisons pas de compromis sur la qualité.

Pour assurer un haut niveau de qualité, nous vérifions chaque étape de fabrication jusqu'au produit final. Chaque produit est mesuré sur des machines de mesure 3D haute précision.



WTO Werkzeug-  
Einrichtungen GmbH  
Neuer Hohdammweg 1  
77797 Ohlsbach  
Allemagne

WTO Inc.  
13900-F South Lakes Dr.  
Charlotte, NC 28273  
États-Unis

WTO Asia  
WTO Precision Tool Holders  
(Shanghai) Co. Ltd.  
Room 109-110, Building 2  
No. 228 Banting Road  
Jiuting Town,  
Songjiang District  
201615 Shanghai  
Chine

## Partenaires de distribution – la compétence sur place

### Australie

Dimac Tooling Ltd.  
sales@dimac.com.au

### Brésil

TF2  
tfdois@tfdois.com.br

### Canada

Mittmann Industrial Inc.  
info@mittmann.com

### Chine

Shanghai Gangde  
wtocando@yahoo.com

### Corée

WTO Office Korea  
is.chon@wto-korea.com

### Danemark

AVN Teknik A/S  
cjo@avn.dk

### Espagne

ITALMATIC, S.A.  
italmatic@italmatic.es

### Finlande

Suomen Terästuonti Oy  
myynti@stt.as

### France Est

Christophe Archambault  
alm@wto.de

### France Ouest

Christophe Archambault  
car@wto.de

### Grande Bretagne

Cutwel Ltd.  
sales@cutwel.net

### Hongrie

Prevotex Hungary Kft.  
info@prevotex.hu

### Inde

Ulhas Patil  
u.patil@wto-asia.com

### Israël

E.Y.A.R. Ltd.  
boris@eyar.co.il

### Italie

Prymark srl  
commerciale@prymark.it

### Japon

NK Works Co. Ltd.  
k\_samba@nk-works.co.jp

### Mexique

Workholding Engineering De México  
info@wem.com.mx

### Norvège

Helge Karlsen Verktøy og Maskin AS  
hkvm@hkvm.no

### Pays-Bas

Toologic BeNeLux B.V.  
info@toologic-benelux.nl

### Pologne

ARCO Andrzej Rudenko  
info@arcotools.pl

### République Tchèque

ALBA precision, spol. s.r.o.  
info@albaprecision.cz

### Roumanie

SC Elif Trading SRL  
bulent.ozkan@eliftrading.com

### Suède

Bonthron & Ewing AB  
info@bonthron-ewing.se

### Suisse

Utilis AG  
info@utilis.com

### Slovaquie

ALBA precision s.r.o.  
albaprecision@albaprecision.sk

### Taiwan

Kaiko Co., Ltd.  
info@kaiko.com.tw

### Turquie

MYK CNC MAKINA SAN. VE  
huseyin.tatlidil@mykcnc.com.tr

### Ukraine

«LLC» SPA Stankopromimport  
info@phoenix-ua.com