

Programma Portautensili

AS-200 (12 ST)
AS-200 (15 ST)
JX-250
MX-100
NTJ-100
NTY³-100, WY-100 II (12 ST)
NTY³-150, 250, WY-150, 250
SC-100
SC-200
SC-250
SC-300 II
SC-450
Super NTJ
Super NTX
TW-30
WT-100
WT-150, WT-150 II, WT-250 II
WT-300

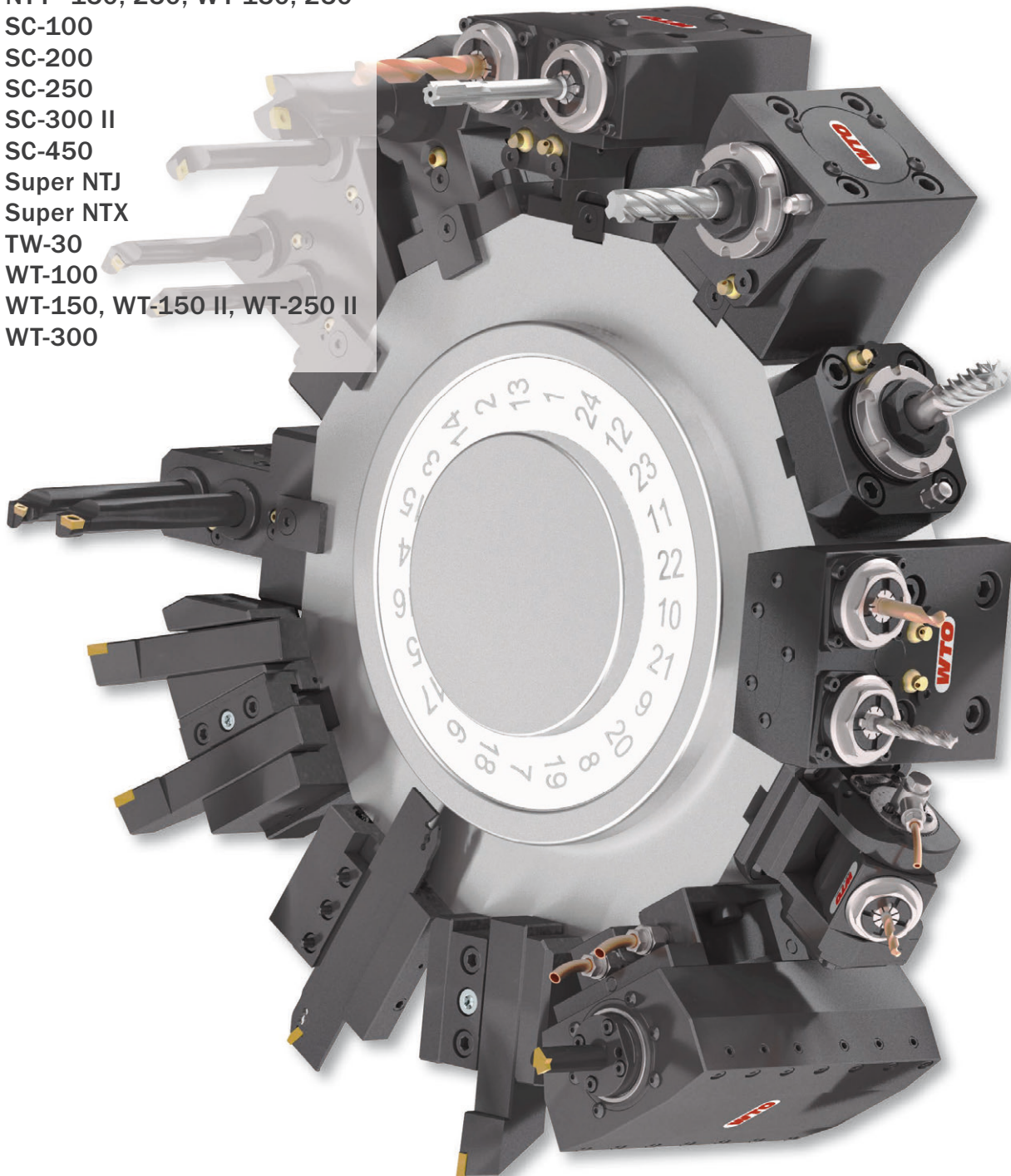

QuickFlex®

Nuovo sistema a cambio rapido per elevate prestazioni e precisione.

Minimo investimento, massima versatilità.



progettato per
torrette BMT

AS-200 (12 ST)	Pagina 4 - 6
AS-200 (15 ST)	Pagina 7 - 9
JX-250	Pagina 10 - 12
MX-100	Pagina 13 - 15
NTJ-100	Pagina 16 - 18
NTY ³ -100, WY-100 II (12 ST)	Pagina 19 - 22
NTY ³ -150, 250, WY-150, 250	Pagina 23 - 26
SC-100	Pagina 27 - 29
SC-200	Pagina 30 - 32
SC-250	Pagina 33 - 36
SC-300 II	Pagina 37 - 39
SC-450	Pagina 40 - 40
Super NTJ	Pagina 41 - 43
Super NTX	Pagina 44 - 46
TW-30	Pagina 47 - 47
WT-100	Pagina 48 - 50
WT-150, WT-150 II, WT-250 II	Pagina 51 - 54
WT-300	Pagina 55 - 57
Bussole di riduzione	Pagina 58 - 58
Pinze	Pagina 59 - 61

EC = adduzione esterna refrigerante
HP-IC = adduzione interna refrigerante alta pressione attraverso l'utensile
IC 80 bar = adduzione esterna ed interna refrigerante
Massima pressione refrigerante = 80 bar
IC 30 bar = adduzione esterna ed interna refrigerante
Massima pressione refrigerante = 30 bar
usare solo refrigerante filtrato (dim. Max. =50 µm)
non utilizzare senza refrigerante!
non utilizzare per lavorazione di ghise

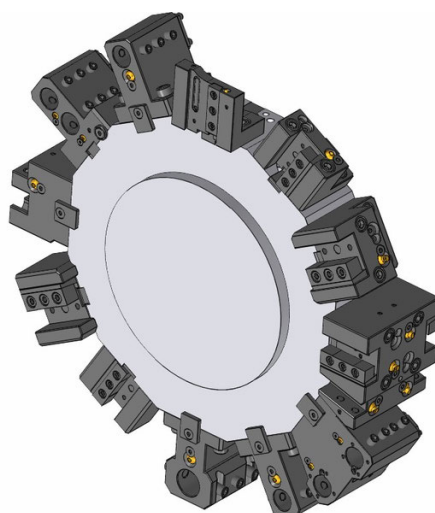
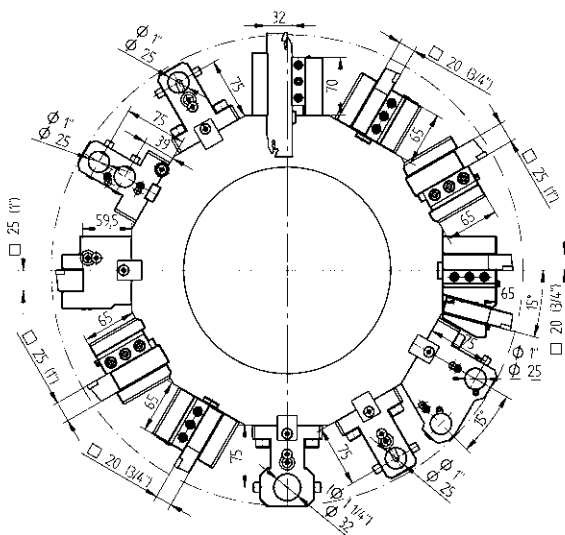

Portautensili statici - Programma standard



Portautensile

20 48-108585
25 48-106720



Portautensile, HP-IC

25 48-106720-HP IC 80 bar



Portautensile per lavorazione su mandrino e contromandrino

20 48-108460



Portautensile per esterni

20 48-108590



Portautensile per esterni

25 48-107758



Portautensile combinato

Ø 25 48-107842 IC 80 bar
Ø 32 48-106727 IC 80 bar

Portautensili statici - Estensione del programma



Portautensile doppio, 24 stazioni (solo per torretta SW375)

20 48-108784 EC



Portautensile per lavorazione su mandrino e contromandrino, doppio, 24 stazioni (solo per torretta SW375)

20 48-108786 EC



Portautensile da taglio

SH 32 48-99637



Portautensile da taglio, HP-IC

SH 32 48-102276R IC 80 bar
SH 32 48-102276L IC 80 bar



Portautensile da taglio, con regolazione, HP-IC

SH 32 48-109656R IC 80 bar
343-810100R87
SH 32 48-109656L IC 80 bar
343-810100L87



Portautensile combinato, doppio

Ø 25 48-108792 IC 80 bar



Portautensile combinato doppio per lavorazione su mandrino e contromandrino, 24 stazioni (solo per torretta SW375)

Ø 25 48-108794 IC 80 bar

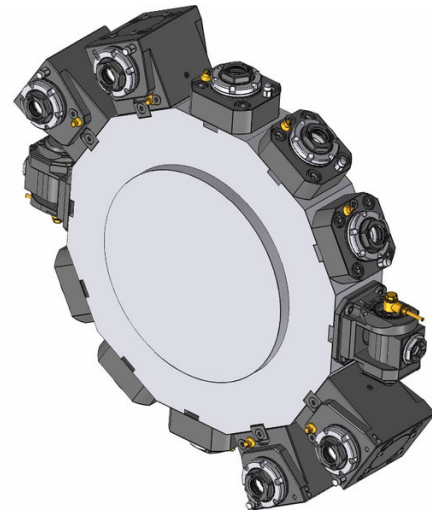
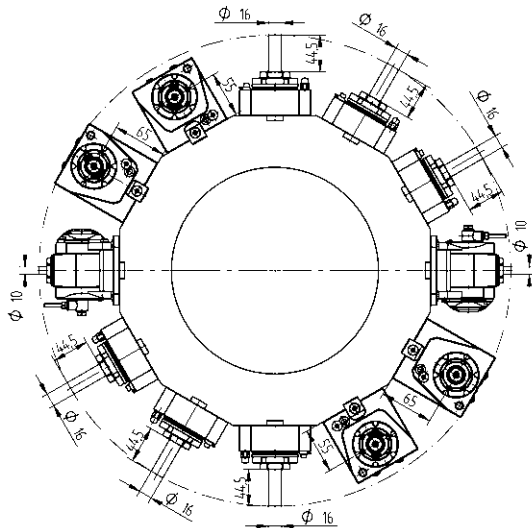

Portautensili Rotanti - QuickFlex®



Portautensile rotante di foratura/fresatura

- | | | | |
|-----------------|--------------|-----|-----------|
| ER-25 QF | 420125022-55 | 1:1 | EC |
| | 0067725000 | | |
| ER-25 QF | 420125023-55 | 1:1 | IC 80 bar |
| | 0067725000 | | |



Portautensile rotante di foratura/fresatura, LF=55

- | | | | |
|-----------------|--------------|-----|-----------|
| ER-25 QF | 420525087-55 | 1:1 | EC |
| | 0067725000 | | |
| ER-25 QF | 420525088-55 | 1:1 | IC 80 bar |
| | 0067725000 | | |



Portautensile rotante di foratura/fresatura, LF=65

- | | | | |
|-----------------|--------------|-----|-----------|
| ER-25 QF | 420525085-55 | 1:1 | EC |
| | 0067725000 | | |
| ER-25 QF | 420525086-55 | 1:1 | IC 80 bar |
| | 0067725000 | | |



Portautensile rotante radiale, per lavorazione su mandrino e contromandrino, LF=55

- | | | | |
|-----------------|--------------|-----|----|
| ER-25 QF | 420525069-55 | 1:1 | EC |
| | 0067725000 | | |



Portautensile rotante radiale, per lavorazione su mandrino e contromandrino, LF=65

- | | | | |
|-----------------|--------------|-----|----|
| ER-25 QF | 420525077-55 | 1:1 | EC |
| | 0067725000 | | |

Portautensili Rotanti - Estensione del programma



Portautensile rotante di foratura/fresatura

- | | | | |
|--------------|--------------|-----|-----------|
| ER 32 | 410120002-55 | 1:1 | EC |
| | 0067825000 | | |
| ER 32 | 410120003-55 | 1:1 | IC 80 bar |
| | 0067825000 | | |



Portautensile rotante di fresatura

- | | | | |
|-------------|--------------|-----|----|
| Ø 22 | 410222002-55 | 1:1 | EC |
| | 00675000483 | | |



Portautensile rotante di foratura/fresatura, disassato

- | | | | |
|--------------|--------------|-----|-----------|
| ER 25 | 410116027-55 | 1:1 | EC |
| | 00675000932 | | |
| ER 25 | 410116028-55 | 1:1 | IC 80 bar |
| | 00675000932 | | |
| ER 20 | 410113006-55 | 1:2 | EC |
| | 00675000939 | | |
| ER 20 | 410113004-55 | 1:2 | IC 80 bar |
| | 00675000939 | | |
| ER 16 | 410410000-55 | 1:3 | EC |
| | 00675000937 | | |
| ER 16 | 410410001-55 | 1:3 | IC 80 bar |
| | 00675000937 | | |
| ER 25 | 410116021-55 | 2:1 | EC |
| | 00675000932 | | |
| ER 25 | 410116022-55 | 2:1 | IC 80 bar |
| | 00675000932 | | |

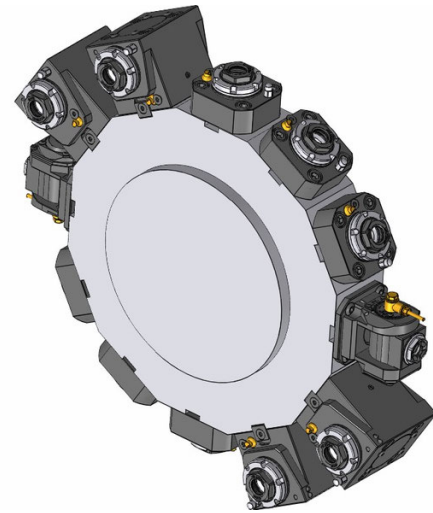
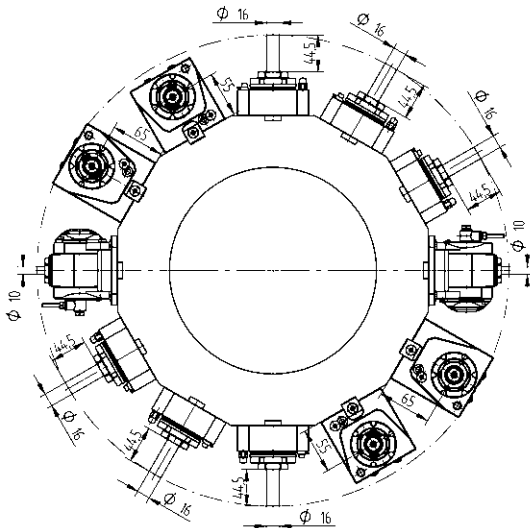

Portautensili Rotanti - Estensione del programma

Portautensili Rotanti - Estensione del programma



Portautensile rotante di foratura/fresatura, LF=65

ER 32	410520045-55 0067825000	1:1	EC
ER 32	410520046-55 0067825000	1:1	IC 80 bar
ER-20 QF	420520029-55 0067720001	1:2	EC
ER-20 QF	420520030-55 0067720001	1:2	IC 80 bar
ER 16	410810022-55 00675000841	1:3	EC
ER 16	410810023-55 00675000841	1:3	IC 80 bar
ER-25 QF	420525055-55 0067725000	2:1	EC
ER-25 QF	420525056-55 0067725000	2:1	IC 80 bar



Portautensile rotante orientabile di foratura/fresatura

ER 16	411010001-55 00675000902	1:1	EC
ER 16	411010002-55 00675000902	1:1	IC 80 bar
ER 11	411007003-55 00675000914	1:2	EC
ER 11	411007004-55 00675000914	1:2	IC 80 bar



Portautensile rotante radiale portafrese combinato DIN6358, LF=65

Ø 22	410622013-55 00675000483	1:1	EC
Ø 22	410622007-55 00675000483	2:1	EC

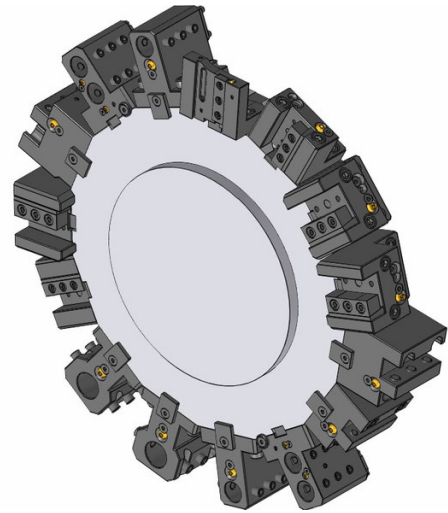
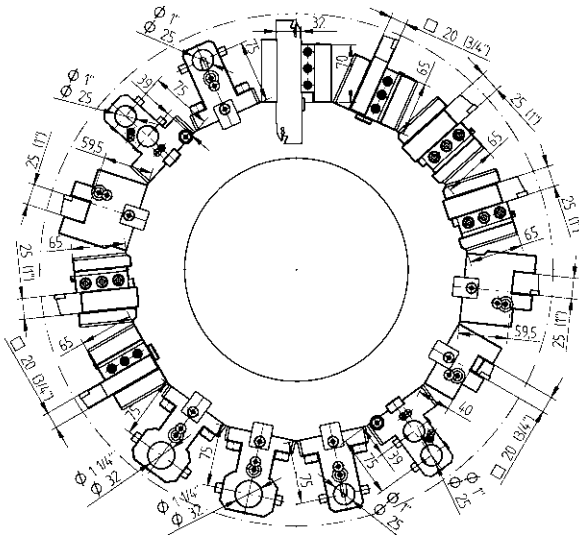

Portautensili statici - Programma standard



Portautensile
 20 48-108585
 25 48-106720



Portautensile, HP-IC
 25 48-106720-HP IC 80 bar



Portautensile per lavorazione su mandrino e contromandrino
 20 48-108460



Portautensile per esterni
 20 48-108590



Portautensile per esterni
 25 48-107758



Portautensile combinato
 Ø 25 48-107842 IC 80 bar
 Ø 32 48-106727 IC 80 bar

Portautensili statici - Estensione del programma

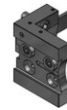

Portautensile da taglio
 SH 32 48-99637



Portautensile da taglio, HP-IC
 SH 32 48-102276R IC 80 bar
 SH 32 48-102276L IC 80 bar



Portautensile da taglio, con regolazione
 SH 32 48-110366 EC



Portautensile da taglio, con regolazione, HP-IC
 SH 32 48-109656R IC 80 bar
 343-810100R87
 SH 32 48-109656L IC 80 bar
 343-810100L87



Portautensile combinato, doppio
 Ø 25 48-108792 IC 80 bar

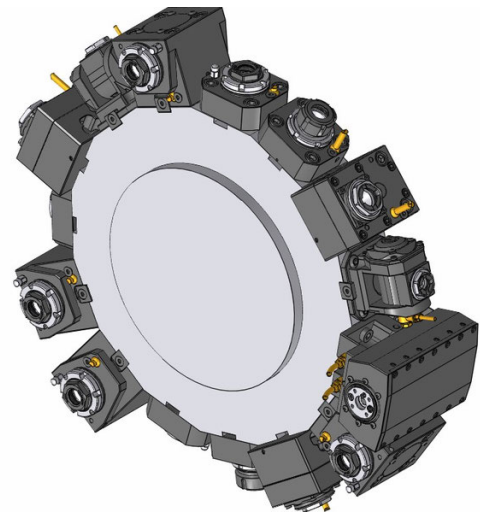
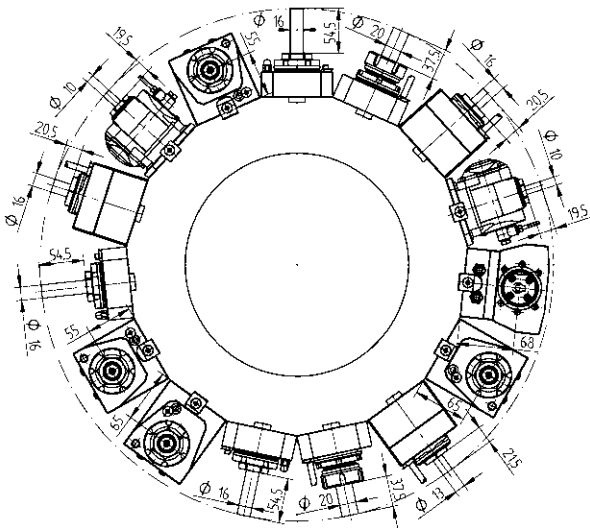

Portautensili Rotanti - QuickFlex®

Portautensili Rotanti - Estensione del programma



Portautensile rotante di foratura/fresatura

- | | | | |
|-----------------|--------------|-----|-----------|
| ER-25 QF | 420125022-55 | 1:1 | EC |
| | 0067725000 | | |
| ER-25 QF | 420125023-55 | 1:1 | IC 80 bar |
| | 0067725000 | | |



Portautensile rotante di foratura/fresatura

- | | | | |
|--------------|--------------|-----|-----------|
| ER 32 | 410120002-55 | 1:1 | EC |
| | 0067825000 | | |
| ER 32 | 410120003-55 | 1:1 | IC 80 bar |
| | 0067825000 | | |



Portautensile rotante di foratura/fresatura, LF=55

- | | | | |
|-----------------|--------------|-----|-----------|
| ER-25 QF | 420525087-55 | 1:1 | EC |
| | 0067725000 | | |
| ER-25 QF | 420525088-55 | 1:1 | IC 80 bar |
| | 0067725000 | | |



Portautensile rotante di fresatura

- | | | | |
|-------------|--------------|-----|----|
| Ø 22 | 410222002-55 | 1:1 | EC |
| | 00675000483 | | |



Portautensile rotante di foratura/fresatura, LF=65

- | | | | |
|-----------------|--------------|-----|-----------|
| ER-25 QF | 420525085-55 | 1:1 | EC |
| | 0067725000 | | |
| ER-25 QF | 420525086-55 | 1:1 | IC 80 bar |
| | 0067725000 | | |



Portautensile rotante di foratura/fresatura, disassato

- | | | | |
|--------------|--------------|-----|-----------|
| ER 25 | 410116027-55 | 1:1 | EC |
| | 00675000932 | | |
| ER 25 | 410116028-55 | 1:1 | IC 80 bar |
| | 00675000932 | | |
| ER 20 | 410113006-55 | 1:2 | EC |
| | 00675000939 | | |
| ER 20 | 410113004-55 | 1:2 | IC 80 bar |
| | 00675000939 | | |
| ER 16 | 410410000-55 | 1:3 | EC |
| | 00675000937 | | |
| ER 16 | 410410001-55 | 1:3 | IC 80 bar |
| | 00675000937 | | |
| ER 25 | 410116021-55 | 2:1 | EC |
| | 00675000932 | | |
| ER 25 | 410116022-55 | 2:1 | IC 80 bar |
| | 00675000932 | | |



Portautensile rotante radiale, per lavorazione su mandrino e contromandrino, LF=55

- | | | | |
|-----------------|--------------|-----|----|
| ER-25 QF | 420525069-55 | 1:1 | EC |
| | 0067725000 | | |



Portautensile rotante radiale, per lavorazione su mandrino e contromandrino, LF=65

- | | | | |
|-----------------|--------------|-----|----|
| ER-25 QF | 420525077-55 | 1:1 | EC |
| | 0067725000 | | |

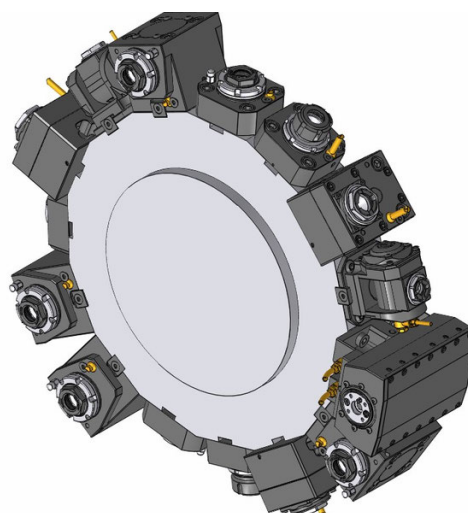
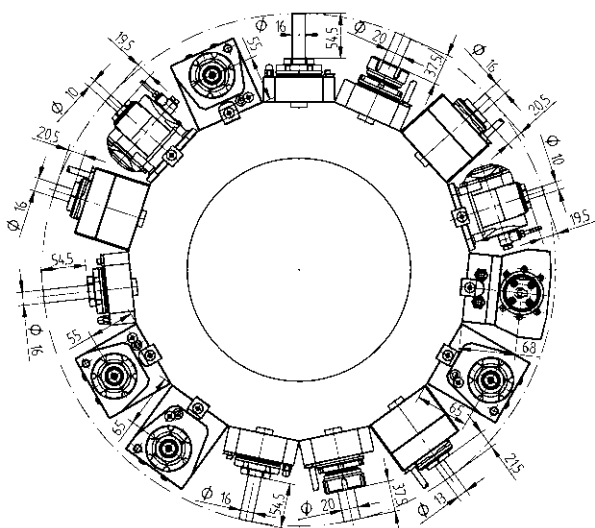

Portautensili Rotanti - Estensione del programma



Portautensile rotante di foratura/fresatura, LF=65

ER 32	410520045-55 0067825000	1:1	EC
ER 32	410520046-55 0067825000	1:1	IC 80 bar
ER-20 QF	420520029-55 0067720001	1:2	EC
ER-20 QF	420520030-55 0067720001	1:2	IC 80 bar
ER 16	410810022-55 00675000841	1:3	EC
ER 16	410810023-55 00675000841	1:3	IC 80 bar
ER-25 QF	420525055-55 0067725000	2:1	EC
ER-25 QF	420525056-55 0067725000	2:1	IC 80 bar



Portautensile rotante radiale portafrese combinato DIN6358, LF=65

Ø 22	410622013-55 00675000483	1:1	EC
Ø 22	410622007-55 00675000483	2:1	EC

Portautensili Rotanti - Estensione del programma



Portautensile rotante radiale arretrato di foratura/fresatura, LF=65

ER 32	410520007-55 00675000592	1:1	EC
ER 32	410520008-55 00675000592	1:1	IC 80 bar
ER 32	410520009-55 00675000592	2:1	EC
ER 32	410520010-55 00675000592	2:1	IC 80 bar



Portautensile rotante orientabile di foratura/fresatura

ER 16	411010001-55 00675000902	1:1	EC
ER 16	411010002-55 00675000902	1:1	IC 80 bar
ER 11	411007003-55 00675000914	1:2	EC
ER 11	411007004-55 00675000914	1:2	IC 80 bar



Unità di brocciatura per interni ed esterni

TN765050	414532003-55	1:1	EC
-----------------	--------------	-----	----

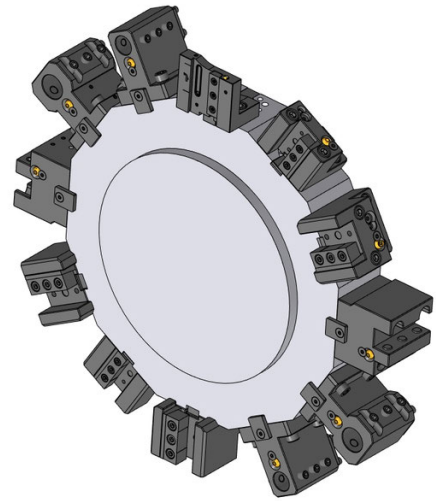
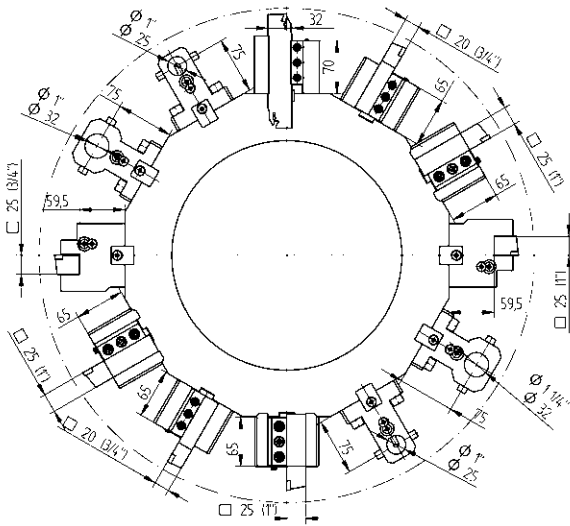

Portautensili statici - Programma standard



Portautensile
 20 48-108585
 25 48-106720



Portautensile, HP-IC
 25 48-106720-HP IC 80 bar



Portautensile per esterni
 25 48-107758



Portautensile combinato
 Ø 25 48-107842 IC 80 bar
 Ø 32 48-106727 IC 80 bar

Portautensili statici - Estensione del programma

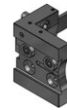

Portautensile da taglio
 SH 32 48-99637



Portautensile da taglio, HP-IC
 SH 32 48-102276R IC 80 bar
 SH 32 48-102276L IC 80 bar



Portautensile da taglio, con regolazione
 SH 32 48-110366 EC



Portautensile da taglio, con regolazione, HP-IC
 SH 32 48-109656R IC 80 bar
 343-810100R87
 SH 32 48-109656L IC 80 bar
 343-810100L87

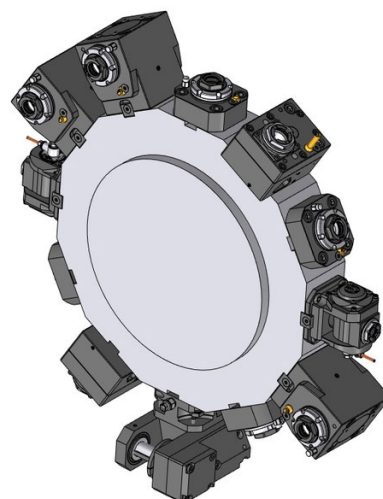
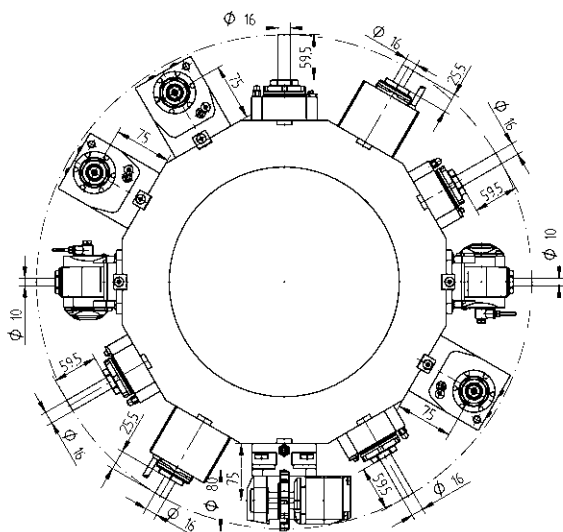

Portautensili Rotanti - QuickFlex®

Portautensili Rotanti - Estensione del programma



Portautensile rotante di foratura/fresatura

- | | | | |
|-----------------|--------------|-----|-----------|
| ER-25 QF | 420125022-55 | 1:1 | EC |
| | 0067725000 | | |
| ER-25 QF | 420125023-55 | 1:1 | IC 80 bar |
| | 0067725000 | | |



Portautensile rotante di foratura/fresatura

- | | | | |
|--------------|--------------|-----|-----------|
| ER 32 | 410120002-55 | 1:1 | EC |
| | 0067825000 | | |
| ER 32 | 410120003-55 | 1:1 | IC 80 bar |
| | 0067825000 | | |



Portautensile rotante di foratura/fresatura, LF=75

- | | | | |
|-----------------|--------------|-----|-----------|
| ER-25 QF | 420525093-55 | 1:1 | EC |
| | 0067725000 | | |
| ER-25 QF | 420525094-55 | 1:1 | IC 80 bar |
| | 0067725000 | | |



Portautensile rotante di fresatura

- | | | | |
|-------------|--------------|-----|----|
| Ø 22 | 410222002-55 | 1:1 | EC |
| | 00675000483 | | |



Portautensile rotante di foratura/fresatura, disassato

- | | | | |
|--------------|--------------|-----|-----------|
| ER 25 | 410116027-55 | 1:1 | EC |
| | 00675000932 | | |
| ER 25 | 410116028-55 | 1:1 | IC 80 bar |
| | 00675000932 | | |
| ER 20 | 410113006-55 | 1:2 | EC |
| | 00675000939 | | |
| ER 20 | 410113004-55 | 1:2 | IC 80 bar |
| | 00675000939 | | |
| ER 16 | 410410000-55 | 1:3 | EC |
| | 00675000937 | | |
| ER 16 | 410410001-55 | 1:3 | IC 80 bar |
| | 00675000937 | | |
| ER 25 | 410116021-55 | 2:1 | EC |
| | 00675000932 | | |
| ER 25 | 410116022-55 | 2:1 | IC 80 bar |
| | 00675000932 | | |

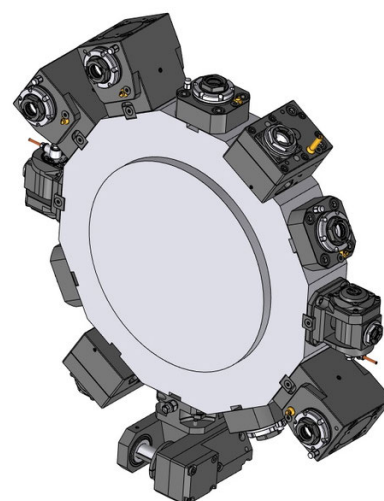
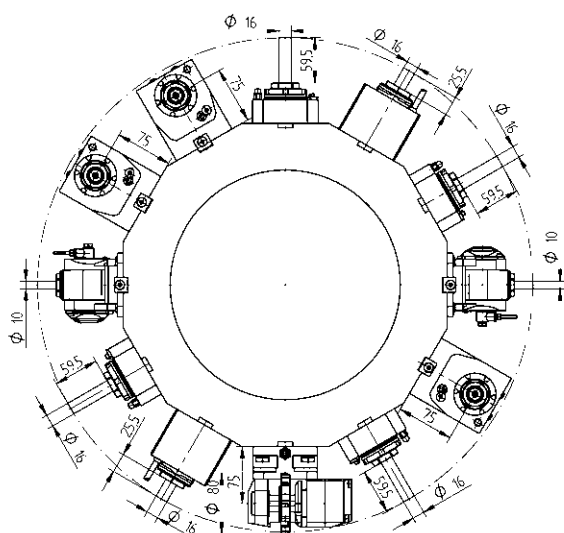

Portautensili Rotanti - Estensione del programma

Portautensili Rotanti - Estensione del programma



Portautensile rotante di foratura/fresatura, LF=75

ER-20 QF	420520027-55 0067720001	1:2	EC
ER-20 QF	420520028-55 0067720001	1:2	IC 80 bar
ER 16	410810024-55 00675000841	1:3	EC
ER 16	410810025-55 00675000841	1:3	IC 80 bar
ER 32	410520022-55 00675000592	2:1	EC
ER 32	410520023-55 00675000592	2:1	IC 80 bar



Portautensile rotante portafrese a disco

Tipo 14-2	411500000-55 00675000489	2,73:1	EC
	160016142 Ø 16		
	160022142 Ø 22		
	160027142 Ø 27		
	160015142 Ø 5/8"		
	160019142 Ø 3/4"		
	160023142 Ø 7/8"		
	160025142 Ø 1"		



Portautensile rotante radiale portafrese combinato DIN6358, LF=75

Ø 22	410622014-55 00675000483	1:1	EC
Ø 22	410622008-55 00675000483	2:1	EC



Portautensile rotante orientabile di foratura/fresatura

ER 16	411010001-55 00675000902	1:1	EC
ER 16	411010002-55 00675000902	1:1	IC 80 bar
ER 11	411007003-55 00675000914	1:2	EC
ER 11	411007004-55 00675000914	1:2	IC 80 bar

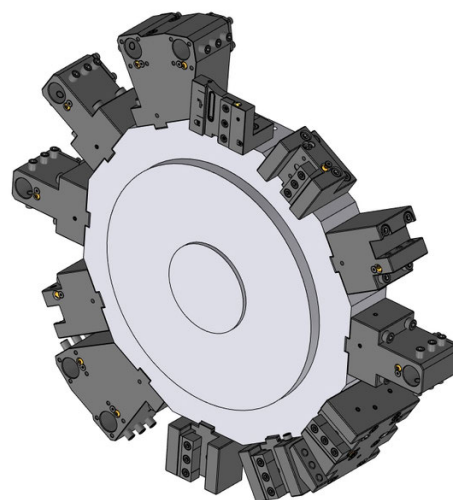
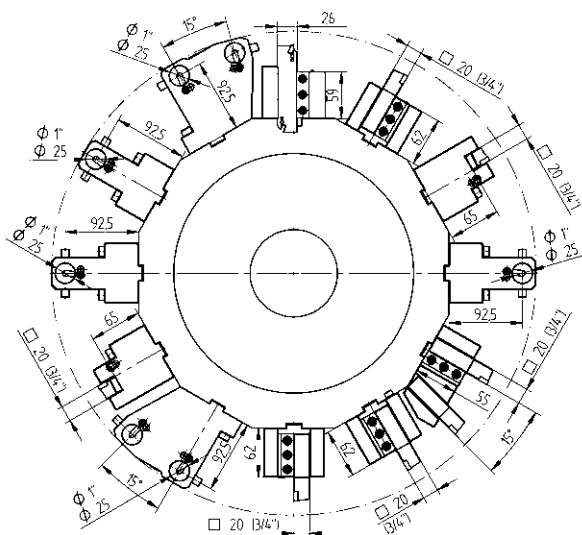

Portautensili statici - Programma standard

Portautensili statici - Estensione del programma



20 Portautensile

48-101470



20 Portautensile, HP-IC

48-101470-HP IC 80 bar



20 Portautensile per lavorazione su mandrino e contromandrino

48-101471



20 Portautensile per esterni

48-102352



Ø 25 Portautensile combinato, LF=92,5

48-106613



20 Portautensile per lavorazione su mandrino e contromandrino, doppio, 24 stazioni (solo per torretta SW390)

48-114360 EC



SH 26 Portautensile da taglio

48-100419



SH 26 Portautensile da taglio, HP-IC

48-102274R IC 80 bar
 48-102274L IC 80 bar
 SH 32 48-112233R IC 80 bar
 343-810100R95
 SH 32 48-112233L IC 80 bar
 343-810100L95



Ø 25 Portautensile combinato, universale, doppio, 24 stazioni (solo per torretta SW390)

48-114362 IC 80 bar

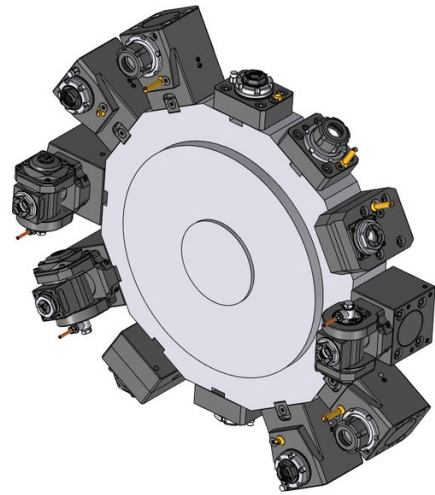
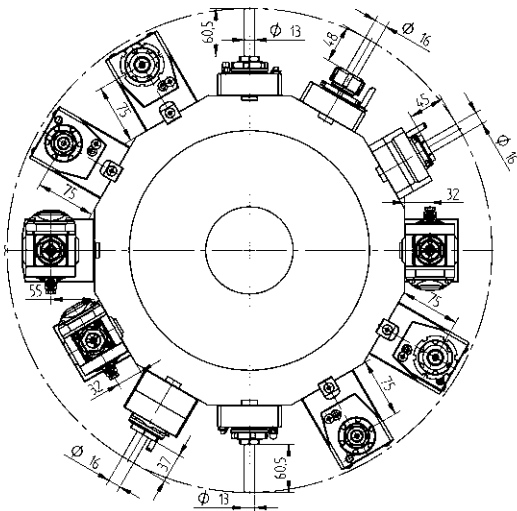

Portautensili Rotanti - QuickFlex®



Portautensile rotante di foratura/fresatura

- | | | | |
|-----------------|--------------|-----|-----------|
| ER-20 QF | 420120010-44 | 1:1 | EC |
| | 0067720000 | | |
| ER-20 QF | 420120011-44 | 1:1 | IC 80 bar |
| | 0067720000 | | |



Portautensile rotante di foratura/fresatura, LF=75

- | | | | |
|-----------------|--------------|-----|-----------|
| ER-20 QF | 420520015-44 | 1:1 | EC |
| | 0067720000 | | |
| ER-20 QF | 420520016-44 | 1:1 | IC 80 bar |
| | 0067720000 | | |

Portautensili Rotanti - Estensione del programma



Portautensile rotante di foratura/fresatura

- | | | | |
|--------------|--------------|-----|-----------|
| ER 25 | 410116004-44 | 1:1 | EC |
| | 00675000720 | | |
| ER 25 | 410116002-44 | 1:1 | IC 80 bar |
| | 00675000720 | | |



Portautensile rotante di foratura/fresatura, disassato

- | | | | |
|--------------|--------------|-------|----|
| ER 20 | 410113004-44 | 1:2 | EC |
| | 00675000939 | | |
| ER 16 | 410110002-44 | 1:3 | EC |
| | 00675000937 | | |
| ER 25 | 410116005-44 | 1,5:1 | EC |
| | 00675000932 | | |



Portautensile rotante di foratura/fresatura, LF=75

- | | | | |
|--------------|--------------|-----|-----------|
| ER 25 | 410516007-44 | 1:1 | EC |
| | 00675000720 | | |
| ER 25 | 410516008-44 | 1:1 | IC 80 bar |
| | 00675000720 | | |

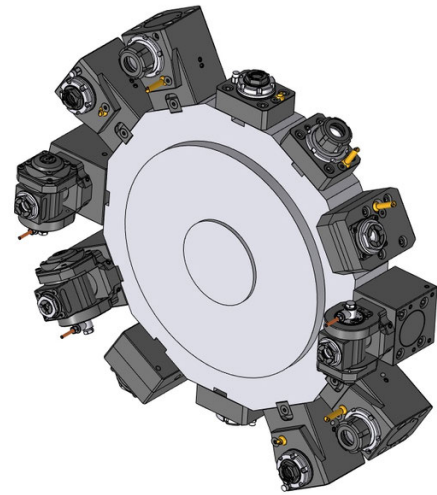
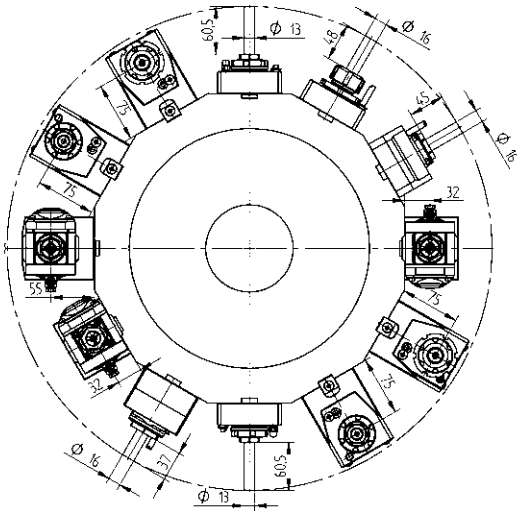

Portautensili Rotanti - Estensione del programma



Portautensile rotante orientabile di foratura/fresatura, LF=32

ER 16	411010004-44	1:1	EC
	00675000902		
ER 16	411010005-44	1:1	IC 80 bar
	00675000902		
ER 11	411007006-44	1:2	EC
	00675000914		
ER 11	411007007-44	1:2	IC 80 bar
	00675000914		



Portautensile rotante orientabile di foratura/fresatura, LF=55

ER 16	411010007-44	1:1	EC
	00675000902		
ER 16	411010011-44	1:1	IC 80 bar
	00675000902		
ER 11	411007009-44	1:2	EC
	00675000914		
ER 11	411007008-44	1:2	IC 80 bar
	00675000914		

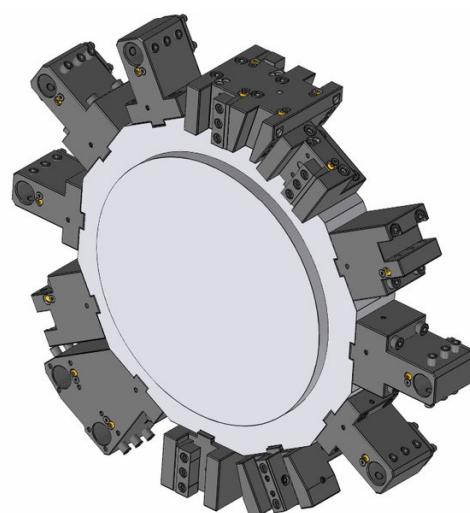
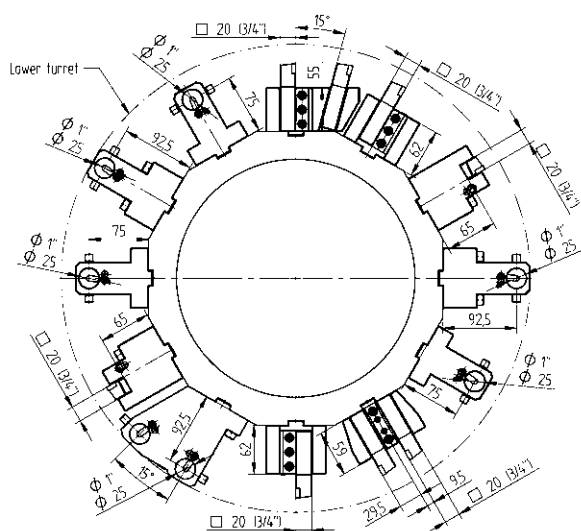

Portautensili statici - Programma standard

Portautensili statici - Estensione del programma



Portautensile

20 48-101470



Portautensile, HP-IC

20 48-101470-HP IC 80 bar



Portautensile per lavorazione su mandrino e contromandrino

20 48-101471



Portautensile per esterni

20 48-102352



Portautensile combinato, LF=75

$\phi 25$ 48-101472



Portautensile combinato, LF=92,5

$\phi 25$ 48-106613



Portautensile doppio, asse Y

20 48-101473



Portautensile per lavorazione su mandrino e contromandrino, doppio, 24 stazioni (solo per torretta SW370)

20 48-108104 EC



Portautensile da taglio

SH 26 48-100419



Portautensile da taglio, HP-IC

SH 26 48-102274R IC 80 bar

SH 26 48-102274L IC 80 bar

SH 32 48-112233R IC 80 bar

343-810100R95

SH 32 48-112233L IC 80 bar

343-810100L95



Portautensile combinato, universale, doppio, 24 stazioni (solo per torretta SW300)

$\phi 25$ 48-107985 IC 80 bar



Portautensile combinato, universale, doppio, 24 stazioni (solo per torretta SW370)

$\phi 25$ 48-108103 IC 80 bar

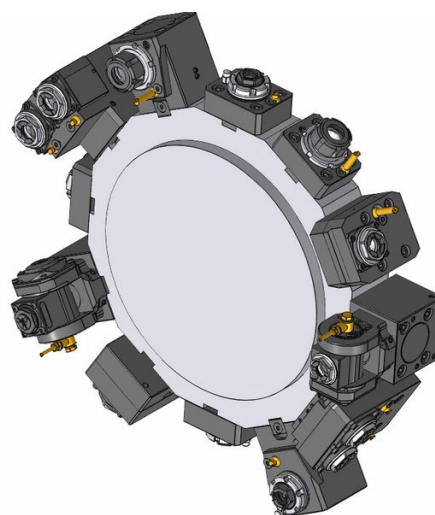
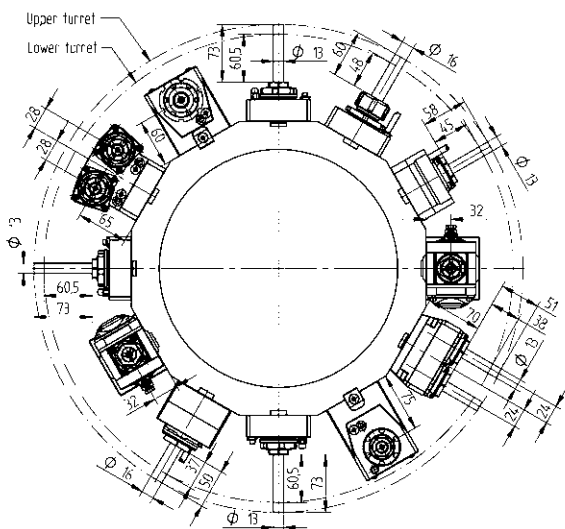

Portautensili Rotanti - QuickFlex®

Portautensili Rotanti - Estensione del programma



Portautensile rotante di foratura/fresatura

- | | | | |
|-----------------|--------------|-----|-----------|
| ER-20 QF | 420120010-44 | 1:1 | EC |
| | 0067720000 | | |
| ER-20 QF | 420120011-44 | 1:1 | IC 80 bar |
| | 0067720000 | | |



Portautensile rotante di foratura/fresatura

- | | | | |
|--------------|--------------|-----|-----------|
| ER 25 | 410116004-44 | 1:1 | EC |
| | 00675000720 | | |
| ER 25 | 410116002-44 | 1:1 | IC 80 bar |
| | 00675000720 | | |



Portautensile rotante di foratura/fresatura, LF=60

- | | | | |
|-----------------|--------------|-----|-----------|
| ER-20 QF | 420520010-44 | 1:1 | EC |
| | 0067720000 | | |
| ER-20 QF | 420520011-44 | 1:1 | IC 80 bar |
| | 0067720000 | | |



Portautensile rotante di foratura/fresatura, disassato

- | | | | |
|--------------|--------------|-------|----|
| ER 20 | 410113004-44 | 1:2 | EC |
| | 00675000939 | | |
| ER 16 | 410110002-44 | 1:3 | EC |
| | 00675000937 | | |
| ER 25 | 410116005-44 | 1,5:1 | EC |
| | 00675000932 | | |



Portautensile rotante di foratura/fresatura, LF=75

- | | | | |
|-----------------|--------------|-----|-----------|
| ER-20 QF | 420520015-44 | 1:1 | EC |
| | 0067720000 | | |
| ER-20 QF | 420520016-44 | 1:1 | IC 80 bar |
| | 0067720000 | | |



Portautensile rotante radiale, per lavorazione su mandrino e contromandrino, LF=60

- | | | | |
|-----------------|--------------|-----|----|
| ER-20 QF | 420520012-44 | 1:1 | EC |
| | 0067720000 | | |

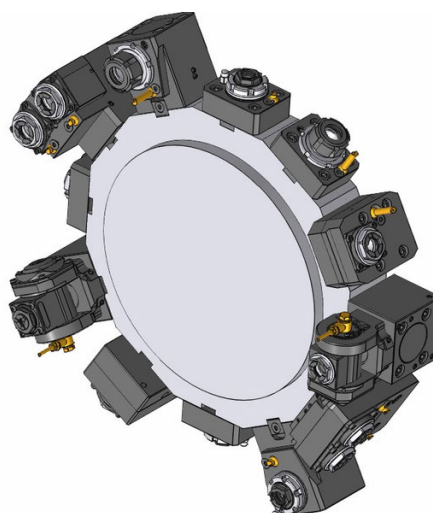
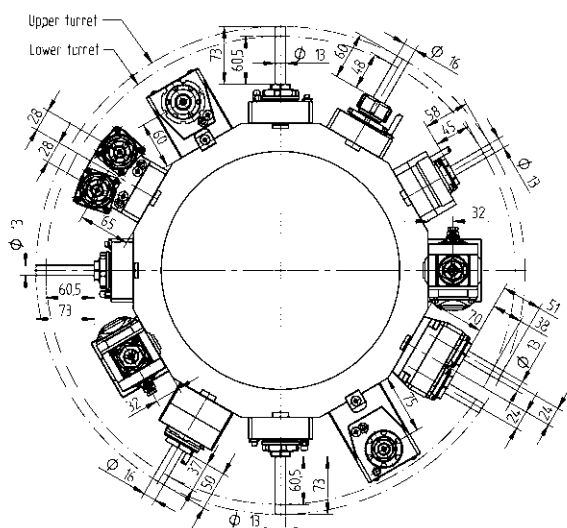

Portautensili Rotanti - Estensione del programma



Portautensile rotante di foratura/fresatura, LF=60

ER 25	410516005-44 00675000720	1:1	EC
ER 25	410516006-44 00675000720	1:1	IC 80 bar
ER 20	410513002-44 00675000833	1:2	EC
ER 20	410513003-44 00675000833	1:2	IC 80 bar
ER 16	410810006-44 00675000841	1:3	EC
ER 16	410810007-44 00675000841	1:3	IC 80 bar
ER 25	410516002-44 00675000720	2:1	EC
ER 25	410516003-44 00675000720	2:1	IC 80 bar



Portautensile rotante di foratura/fresatura, LF=75

ER 25	410516007-44 00675000720	1:1	EC
ER 25	410516008-44 00675000720	1:1	IC 80 bar



Portautensile rotante radiale portafrese combinato DIN6358, LF=60

Ø 22	410622000-44 00675000483	1:1	EC
Ø 22	410622001-44 00675000483	2:1	EC

Portautensili Rotanti - Estensione del programma



Portautensile rotante orientabile di foratura/fresatura, LF=32

ER 16	411010004-44 00675000902	1:1	EC
ER 16	411010005-44 00675000902	1:1	IC 80 bar
ER 11	411007006-44 00675000914	1:2	EC
ER 11	411007007-44 00675000914	1:2	IC 80 bar



Portautensile rotante di foratura/fresatura - doppio, asse Y

ER 20	413002003-44 00675000939	1:1	EC
ER 20	413002004-44 00675000939	1:1	IC 80 bar



Portautensile rotante di foratura/fresatura a 2 uscite, asse Y

ER 20	413502004-44 00675000939	1:1	EC
ER 20	413502005-44 00675000939	1:1	IC 80 bar

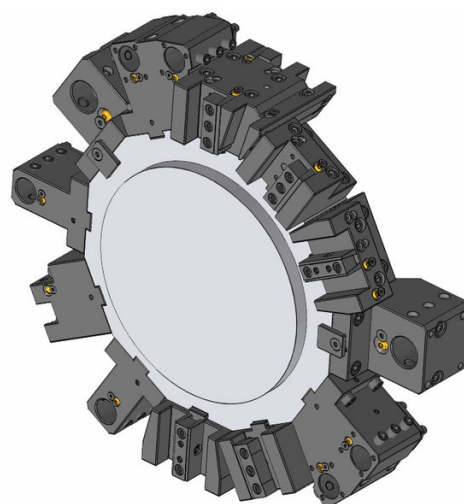
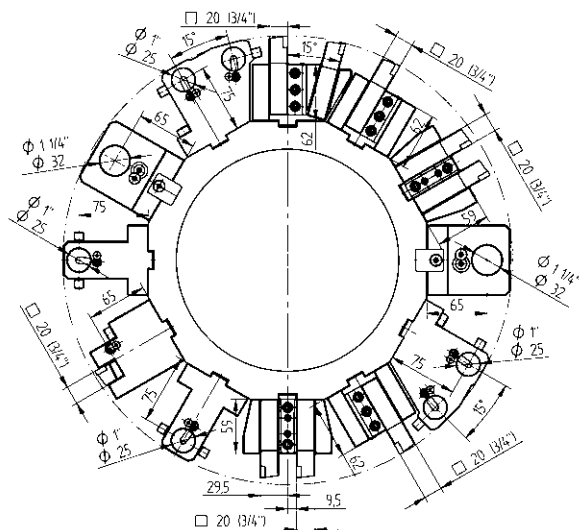

Portautensili statici - Programma standard

Portautensili statici - Estensione del programma

- 

Portautensile
20 48-101470
- 

Portautensile, HP-IC
20 48-101470-HP IC 80 bar
- 

Portautensile per lavorazione su mandrino e contromandrino
20 48-101471
- 

Portautensile per esterni
20 48-102352
- 

Portautensile combinato, LF=75
Ø 25 48-101472
- 

Portautensile combinato
Ø 32 48-107155

- 

Portautensile doppio, asse Y
20 48-101473
- 

Portautensile per lavorazione su mandrino e contromandrino, doppio, 24 stazioni (solo per torretta SW300)
20 48-107973 EC
- 

Portautensile da taglio
SH 26 48-100419
- 

Portautensile da taglio, HP-IC
SH 26 48-102274R IC 80 bar
SH 26 48-102274L IC 80 bar
SH 32 48-112233R IC 80 bar
343-810100R95
SH 32 48-112233L IC 80 bar
343-810100L95
- 

Portautensile combinato, universale, doppio, 24 stazioni (solo per torretta SW300)
Ø 25 48-107985 IC 80 bar

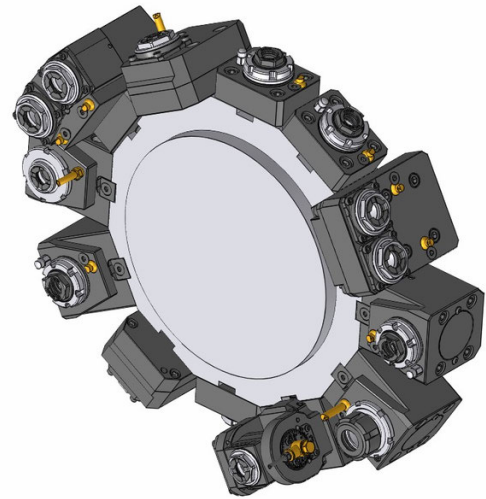
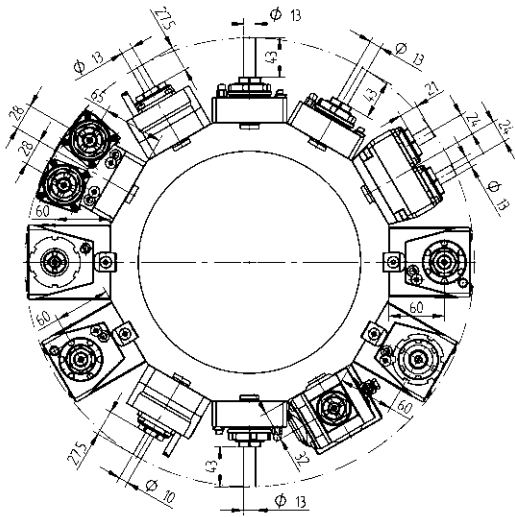

Portautensili Rotanti - QuickFlex®

Portautensili Rotanti - QuickFlex®



Portautensile rotante di foratura/fresatura

- ER-20 QF 420120010-44 1:1 EC
 0067720000
- ER-20 QF 420120011-44 1:1 IC 80 bar
 0067720000



Portautensile rotante radiale, per lavorazione su mandrino e contromandrino, LF=60

- ER-20 QF 420520012-44 1:1 EC
 0067720000



Portautensile rotante di foratura/fresatura assiale (8000 RPM)

- ER-20 QF 420120010-44-S 1:1 EC
 0067720000
- ER-20 QF 420120011-44-S 1:1 IC 80 bar
 0067720000



Portautensile rotante di foratura/fresatura, LF=60

- ER-20 QF 420520010-44 1:1 EC
 0067720000
- ER-20 QF 420520011-44 1:1 IC 80 bar
 0067720000



Portautensile rotante radiale, LF=60, (8000 RPM)

- ER-20 QF 420520010-44-S 1:1 EC
 0067720000
- ER-20 QF 420520011-44-S 1:1 IC 80 bar
 0067720000

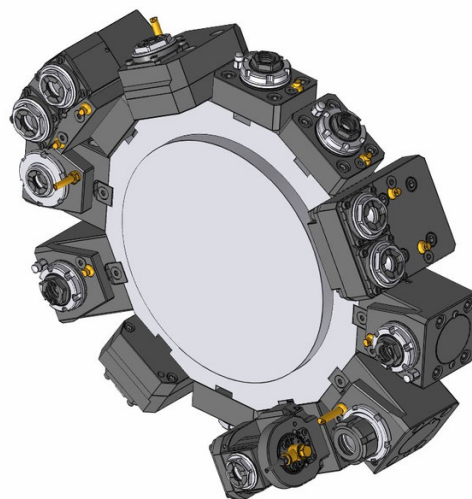
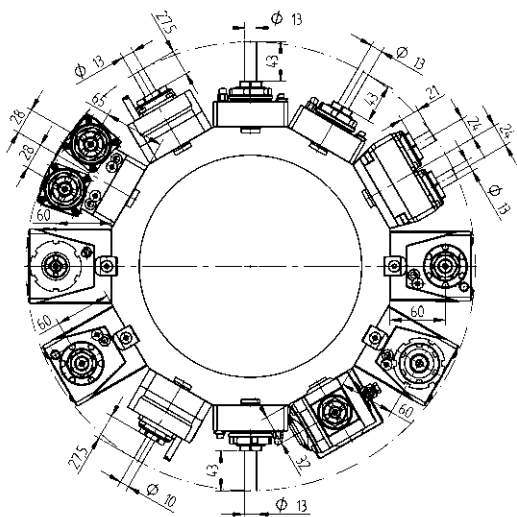

Portautensili Rotanti - Estensione del programma



Portautensile rotante di foratura/fresatura

ER 25	410116004-44 00675000720	1:1	EC
ER 25	410116002-44 00675000720	1:1	IC 80 bar



Portautensile rotante di foratura/fresatura assiale (8000 RPM)

ER 25	410116004-44-S 00675000720	1:1	EC
ER 25	410116002-44-S 00675000720	1:1	IC 80 bar



Portautensile rotante di foratura/fresatura, disassato

ER 20	410113004-44 00675000939	1:2	EC
ER 16	410110002-44 00675000937	1:3	EC
ER 25	410116005-44 00675000932	1,5:1	EC

Portautensili Rotanti - Estensione del programma



Portautensile rotante di foratura/fresatura, LF=60

ER 25	410516005-44 00675000720	1:1	EC
ER 25	410516006-44 00675000720	1:1	IC 80 bar
ER 20	410513002-44 00675000833	1:2	EC
ER 20	410513003-44 00675000833	1:2	IC 80 bar
ER 16	410810006-44 00675000841	1:3	EC
ER 16	410810007-44 00675000841	1:3	IC 80 bar
ER 25	410516002-44 00675000720	2:1	EC
ER 25	410516003-44 00675000720	2:1	IC 80 bar



Portautensile rotante radiale, LF=60, (8000 RPM)

ER 25	410516005-44-S 00675000720	1:1	EC
ER 25	410516006-44-S 00675000720	1:1	IC 80 bar



Portautensile rotante radiale portafrese combinato DIN6358, LF=60

Ø 22	410622000-44 00675000483	1:1	EC
Ø 22	410622001-44 00675000483	2:1	EC

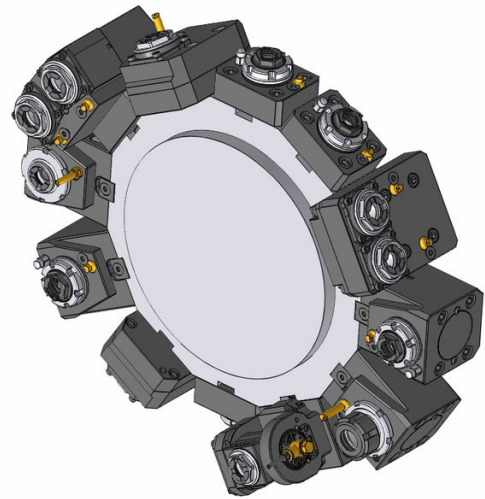
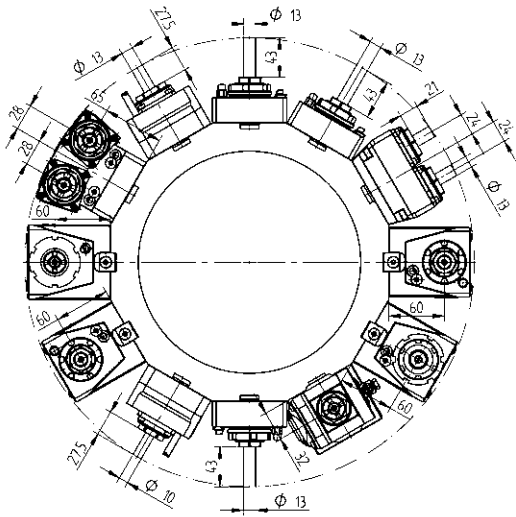

Portautensili Rotanti - Estensione del programma

Portautensili Rotanti - Estensione del programma



Portautensile rotante orientabile di foratura/fresatura, LF=32

ER 16	411010004-44 00675000902	1:1	EC
ER 16	411010005-44 00675000902	1:1	IC 80 bar
ER 11	411007006-44 00675000914	1:2	EC
ER 11	411007007-44 00675000914	1:2	IC 80 bar



Portautensile rotante di foratura/fresatura a 2 uscite, asse Y

ER 20	413502004-44 00675000939	1:1	EC
ER 20	413502005-44 00675000939	1:1	IC 80 bar



Portautensile rotante orientabile di foratura/fresatura, LF=55

ER 16	411010007-44 00675000902	1:1	EC
ER 16	411010011-44 00675000902	1:1	IC 80 bar
ER 11	411007009-44 00675000914	1:2	EC
ER 11	411007008-44 00675000914	1:2	IC 80 bar



Portautensile rotante di foratura/fresatura - doppio, asse Y

ER 20	413002003-44 00675000939	1:1	EC
ER 20	413002004-44 00675000939	1:1	IC 80 bar

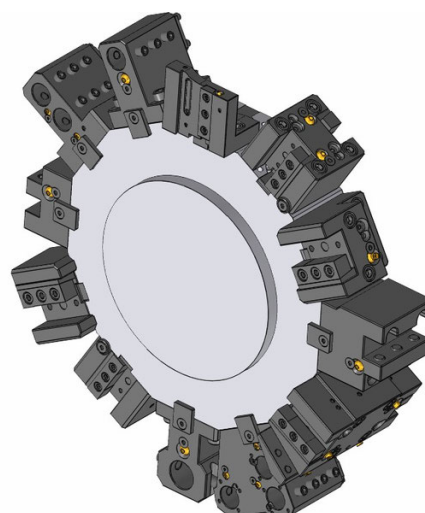
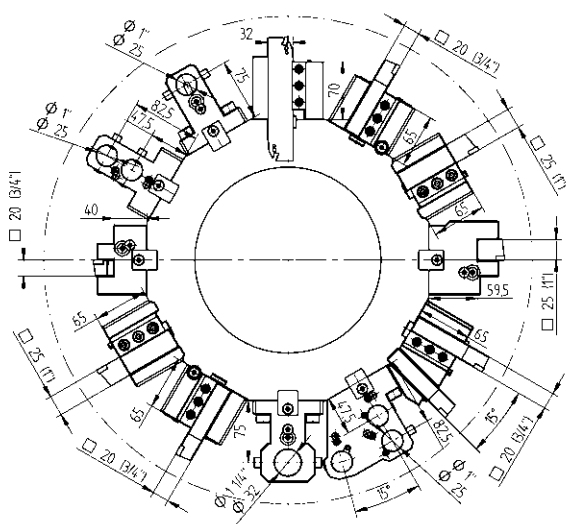

Portautensili statici - Programma standard

Portautensili statici - Estensione del programma



Portautensile
20 48-108585
25 48-106720



Portautensile, HP-IC
25 48-106720-HP IC 80 bar



Portautensile per lavorazione su mandrino e contromandrino
20 48-108460



Portautensile per esterni
20 48-108590



Portautensile per esterni
25 48-107758



Portautensile combinato
Ø 25 48-107842 IC 80 bar
Ø 32 48-106727 IC 80 bar



Portautensile doppio, 24 stazioni (solo per torretta SW340)
20 48-108592 EC



Portautensile per lavorazione su mandrino e contromandrino, doppio, 24 stazioni (solo per torretta SW340)
20 48-108461 EC



Portautensile da taglio
SH 32 48-99637



Portautensile da taglio, HP-IC
SH 32 48-102276R IC 80 bar
SH 32 48-102276L IC 80 bar



Portautensile da taglio, con regolazione, HP-IC
SH 32 48-109656R IC 80 bar
343-810100R87
SH 32 48-109656L IC 80 bar
343-810100L87



Portautensile combinato, doppio
Ø 25 48-108596 IC 80 bar



Portautensile combinato, universale, triplo, 24 stazioni (solo per torretta SW340)
Ø 25 48-108462 IC 80 bar

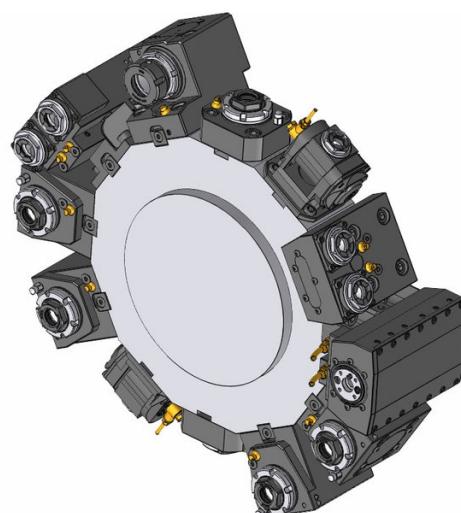
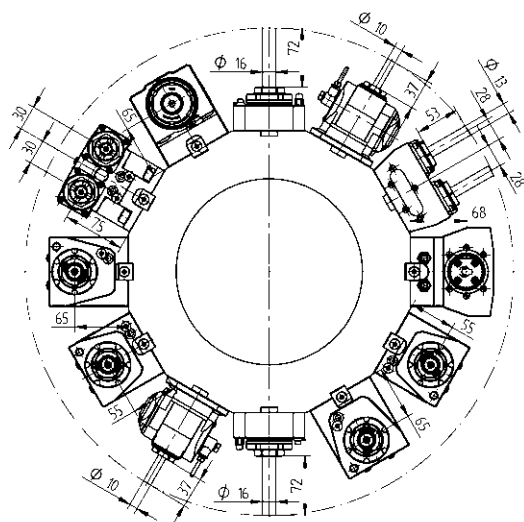

Portautensili Rotanti - QuickFlex®

Portautensili Rotanti - Estensione del programma



Portautensile rotante di foratura/fresatura

- | | | | |
|-----------------|--------------|-----|-----------|
| ER-25 QF | 420125022-55 | 1:1 | EC |
| | 0067725000 | | |
| ER-25 QF | 420125023-55 | 1:1 | IC 80 bar |
| | 0067725000 | | |



Portautensile rotante di foratura/fresatura

- | | | | |
|--------------|--------------|-----|-----------|
| ER 32 | 410120002-55 | 1:1 | EC |
| | 0067825000 | | |
| ER 32 | 410120003-55 | 1:1 | IC 80 bar |
| | 0067825000 | | |



Portautensile rotante di foratura/fresatura, LF=55

- | | | | |
|-----------------|--------------|-----|-----------|
| ER-25 QF | 420525087-55 | 1:1 | EC |
| | 0067725000 | | |
| ER-25 QF | 420525088-55 | 1:1 | IC 80 bar |
| | 0067725000 | | |



Portautensile rotante di fresatura

- | | | | |
|-------------|--------------|-----|----|
| Ø 22 | 410222002-55 | 1:1 | EC |
| | 00675000483 | | |



Portautensile rotante di foratura/fresatura, LF=65

- | | | | |
|-----------------|--------------|-----|-----------|
| ER-25 QF | 420525085-55 | 1:1 | EC |
| | 0067725000 | | |
| ER-25 QF | 420525086-55 | 1:1 | IC 80 bar |
| | 0067725000 | | |



Portautensile rotante di foratura/fresatura, disassato

- | | | | |
|--------------|--------------|-----|-----------|
| ER 25 | 410116027-55 | 1:1 | EC |
| | 00675000932 | | |
| ER 25 | 410116028-55 | 1:1 | IC 80 bar |
| | 00675000932 | | |
| ER 20 | 410113006-55 | 1:2 | EC |
| | 00675000939 | | |
| ER 20 | 410113004-55 | 1:2 | IC 80 bar |
| | 00675000939 | | |
| ER 16 | 410410000-55 | 1:3 | EC |
| | 00675000937 | | |
| ER 16 | 410410001-55 | 1:3 | IC 80 bar |
| | 00675000937 | | |
| ER 25 | 410116021-55 | 2:1 | EC |
| | 00675000932 | | |
| ER 25 | 410116022-55 | 2:1 | IC 80 bar |
| | 00675000932 | | |



Portautensile rotante radiale, per lavorazione su mandrino e contromandrino, LF=55

- | | | | |
|-----------------|--------------|-----|----|
| ER-25 QF | 420525069-55 | 1:1 | EC |
| | 0067725000 | | |



Portautensile rotante radiale, per lavorazione su mandrino e contromandrino, LF=65

- | | | | |
|-----------------|--------------|-----|----|
| ER-25 QF | 420525077-55 | 1:1 | EC |
| | 0067725000 | | |

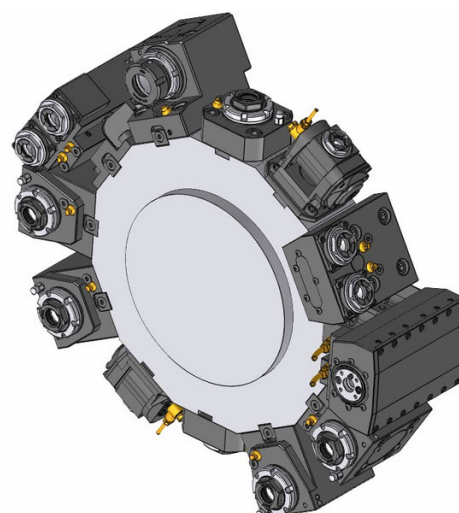
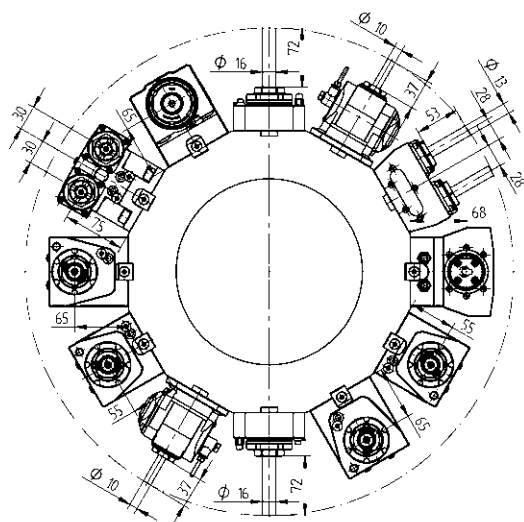

Portautensili Rotanti - Estensione del programma



Portautensile rotante di foratura/fresatura, LF=65

ER 32	410520045-55 0067825000	1:1	EC
ER 32	410520046-55 0067825000	1:1	IC 80 bar
ER-20 QF	420520029-55 0067720001	1:2	EC
ER-20 QF	420520030-55 0067720001	1:2	IC 80 bar
ER 16	410810022-55 00675000841	1:3	EC
ER 16	410810023-55 00675000841	1:3	IC 80 bar
ER-25 QF	420525055-55 0067725000	2:1	EC
ER-25 QF	420525056-55 0067725000	2:1	IC 80 bar



Portautensile rotante radiale portafrese combinato DIN6358, LF=65

Ø 22	410622013-55 00675000483	1:1	EC
Ø 22	410622007-55 00675000483	2:1	EC

Portautensili Rotanti - Estensione del programma



Portautensile rotante radiale arretrato di foratura/fresatura, LF=65

ER 32	410520007-55 00675000592	1:1	EC
ER 32	410520008-55 00675000592	1:1	IC 80 bar
ER 32	410520009-55 00675000592	2:1	EC
ER 32	410520010-55 00675000592	2:1	IC 80 bar



Portautensile rotante orientabile di foratura/fresatura

ER 16	411010001-55 00675000902	1:1	EC
ER 16	411010002-55 00675000902	1:1	IC 80 bar
ER 11	411007003-55 00675000914	1:2	EC
ER 11	411007004-55 00675000914	1:2	IC 80 bar

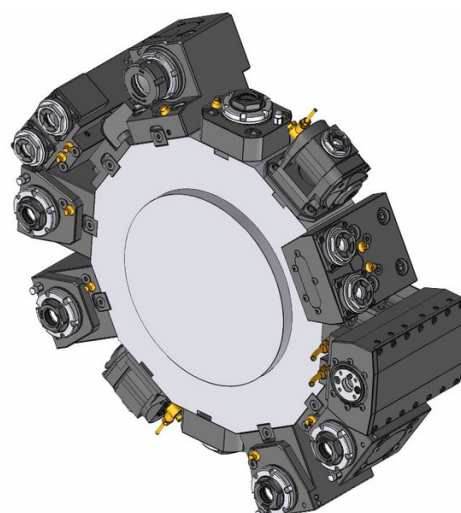
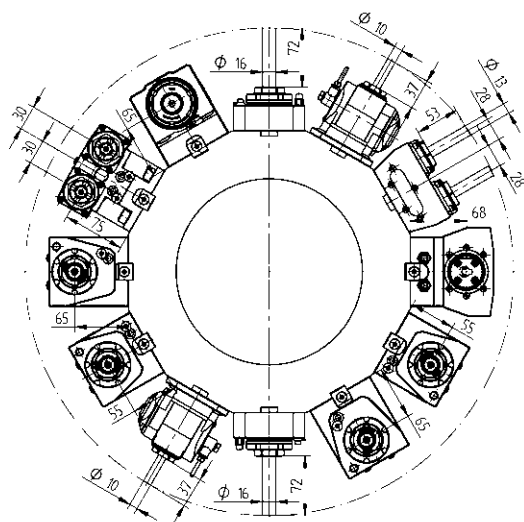

Portautensili Rotanti - Estensione del programma



Portautensile rotante portafrese a disco

Tipo 14-2 411500000-55 2,73:1 EC

00675000489

160016142 Ø 16

160022142 Ø 22

160027142 Ø 27

160015142 Ø 5/8"

160019142 Ø 3/4"

160023142 Ø 7/8"

160025142 Ø 1"



Portautensile rotante di foratura/fresatura - doppio, asse Y

ER 20 413002001-55 1:1 EC

00675000944



Portautensile rotante di foratura/fresatura a 2 uscite, asse Y

ER 20 413502012-55 1:1 EC

00675000944



Unità di brocciatura per interni ed esterni

TN765050 414532003-55 1:1 EC

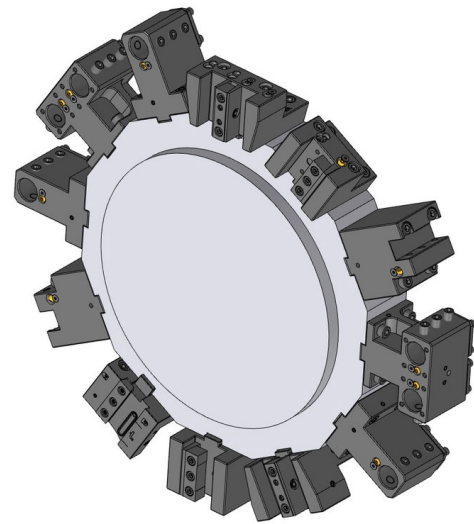
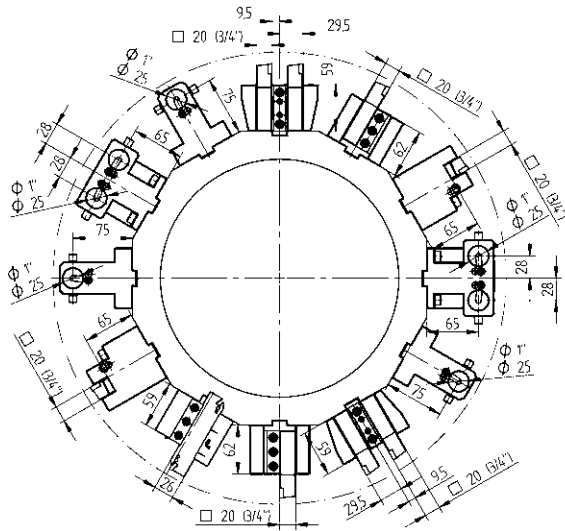

Portautensili statici - Programma standard

Portautensili statici - Estensione del programma



Portautensile
20 48-101470



Portautensile, HP-IC
20 48-101470-HP IC 80 bar



Portautensile per lavorazione su mandrino e contromandrino
20 48-101471



Portautensile per esterni
20 48-102352



Portautensile combinato, LF=75
Ø 25 48-101472



Portautensile doppio, asse Y
20 48-101473



Portautensile da taglio
SH 26 48-100419



Portautensile da taglio, HP-IC
SH 26 48-102274R IC 80 bar
SH 26 48-102274L IC 80 bar
SH 32 48-112233R IC 80 bar
343-810100R95
SH 32 48-112233L IC 80 bar
343-810100L95



Portautensile combinato doppio, asse Y
Ø 25 48-101474

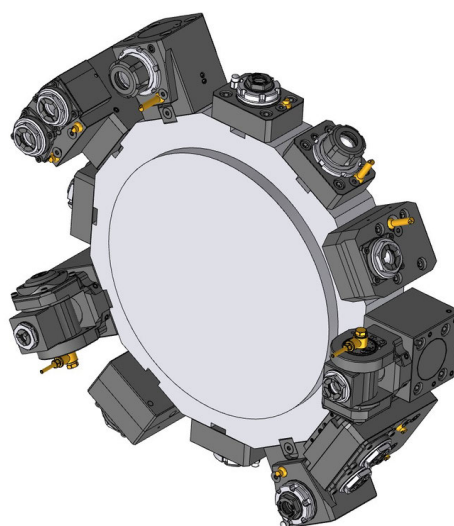
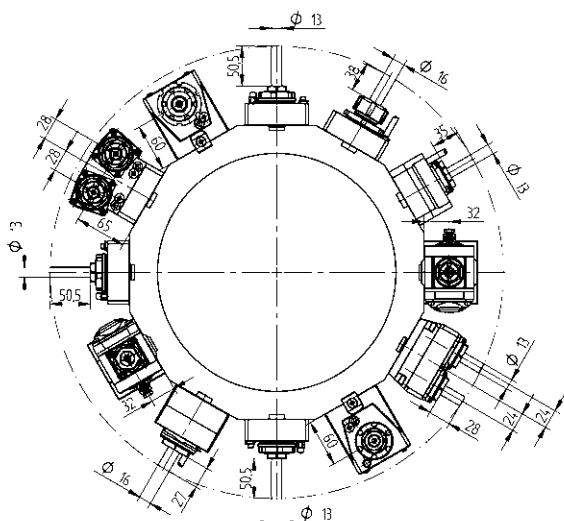

Portautensili Rotanti - QuickFlex®

Portautensili Rotanti - Estensione del programma



Portautensile rotante di foratura/fresatura

- | | | | |
|-----------------|--------------|-----|-----------|
| ER-20 QF | 420120010-44 | 1:1 | EC |
| | 0067720000 | | |
| ER-20 QF | 420120011-44 | 1:1 | IC 80 bar |
| | 0067720000 | | |



Portautensile rotante di foratura/fresatura

- | | | | |
|--------------|--------------|-----|-----------|
| ER 25 | 410116004-44 | 1:1 | EC |
| | 00675000720 | | |
| ER 25 | 410116002-44 | 1:1 | IC 80 bar |
| | 00675000720 | | |



Portautensile rotante di foratura/fresatura, LF=60

- | | | | |
|-----------------|--------------|-----|-----------|
| ER-20 QF | 420520010-44 | 1:1 | EC |
| | 0067720000 | | |
| ER-20 QF | 420520011-44 | 1:1 | IC 80 bar |
| | 0067720000 | | |



Portautensile rotante di foratura/fresatura, disassato

- | | | | |
|--------------|--------------|-------|----|
| ER 20 | 410113004-44 | 1:2 | EC |
| | 00675000939 | | |
| ER 16 | 410110002-44 | 1:3 | EC |
| | 00675000937 | | |
| ER 25 | 410116005-44 | 1,5:1 | EC |
| | 00675000932 | | |



Portautensile rotante di foratura/fresatura, LF=75

- | | | | |
|-----------------|--------------|-----|-----------|
| ER-20 QF | 420520015-44 | 1:1 | EC |
| | 0067720000 | | |
| ER-20 QF | 420520016-44 | 1:1 | IC 80 bar |
| | 0067720000 | | |

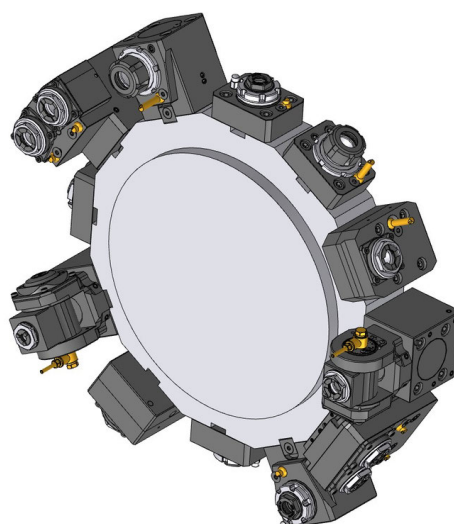
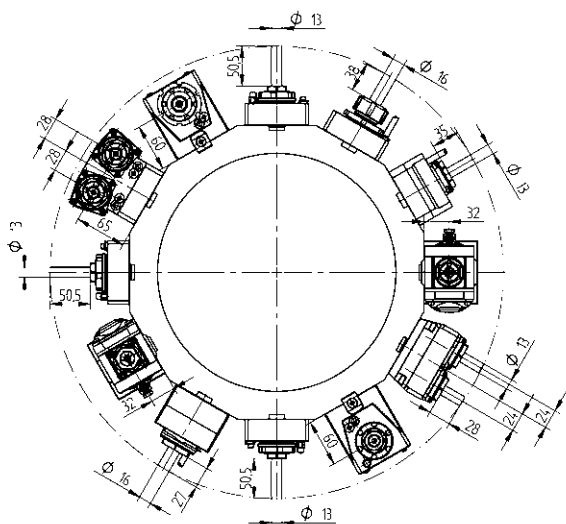

Portautensili Rotanti - Estensione del programma

Portautensili Rotanti - Estensione del programma



Portautensile rotante di foratura/fresatura, LF=60

ER 25	410516005-44 00675000720	1:1	EC
ER 25	410516006-44 00675000720	1:1	IC 80 bar
ER 20	410513002-44 00675000833	1:2	EC
ER 20	410513003-44 00675000833	1:2	IC 80 bar
ER 16	410810006-44 00675000841	1:3	EC
ER 16	410810007-44 00675000841	1:3	IC 80 bar
ER 25	410516002-44 00675000720	2:1	EC
ER 25	410516003-44 00675000720	2:1	IC 80 bar



Portautensile rotante orientabile di foratura/fresatura, LF=32

ER 16	411010004-44 00675000902	1:1	EC
ER 16	411010005-44 00675000902	1:1	IC 80 bar
ER 11	411007006-44 00675000914	1:2	EC
ER 11	411007007-44 00675000914	1:2	IC 80 bar



Portautensile rotante di foratura/fresatura - doppio, asse Y

ER 20	413002003-44 00675000939	1:1	EC
ER 20	413002004-44 00675000939	1:1	IC 80 bar



Portautensile rotante di foratura/fresatura, LF=75

ER 25	410516007-44 00675000720	1:1	EC
ER 25	410516008-44 00675000720	1:1	IC 80 bar



Portautensile rotante di foratura/fresatura a 2 uscite, asse Y

ER 20	413502004-44 00675000939	1:1	EC
ER 20	413502005-44 00675000939	1:1	IC 80 bar



Portautensile rotante radiale portafrese combinato DIN6358, LF=60

Ø 22	410622000-44 00675000483	1:1	EC
Ø 22	410622001-44 00675000483	2:1	EC

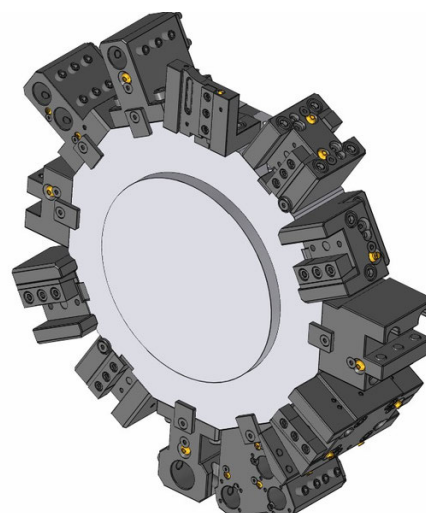
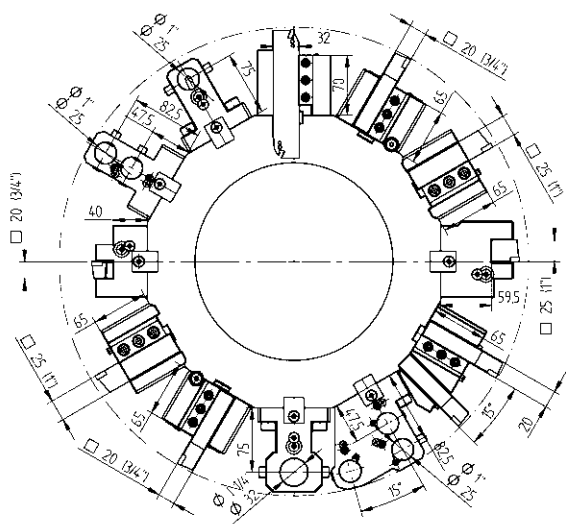

Portautensili statici - Programma standard



Portautensile
20 48-108585
25 48-106720



Portautensile, HP-IC
25 48-106720-HP IC 80 bar



Portautensile per lavorazione su mandrino e contromandrino
20 48-108460



Portautensile per esterni
20 48-108590



Portautensile per esterni
25 48-107758



Portautensile combinato
Ø 25 48-107842 IC 80 bar
Ø 32 48-106727 IC 80 bar

Portautensili statici - Estensione del programma



Portautensile doppio, 24 stazioni (solo per torretta SW340)
20 48-108592 EC



Portautensile per lavorazione su mandrino e contromandrino, doppio, 24 stazioni (solo per torretta SW340)
20 48-108461 EC



Portautensile da taglio
SH 32 48-99637



Portautensile da taglio, HP-IC
SH 32 48-102276R IC 80 bar
SH 32 48-102276L IC 80 bar



Portautensile da taglio, con regolazione, HP-IC
SH 32 48-109656R IC 80 bar
343-810100R87
SH 32 48-109656L IC 80 bar
343-810100L87



Portautensile combinato, doppio
Ø 25 48-108596 IC 80 bar



Portautensile combinato, universale, triplo, 24 stazioni (solo per torretta SW340)
Ø 25 48-108462 IC 80 bar

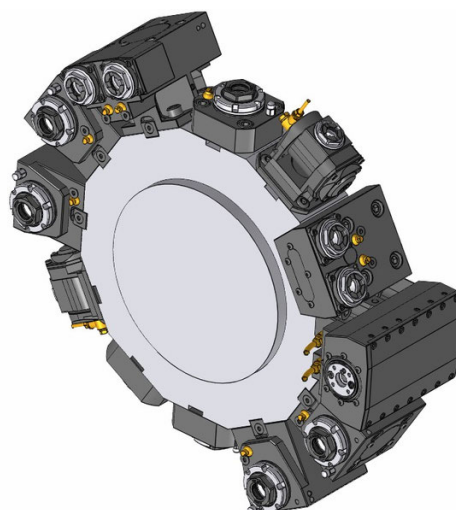
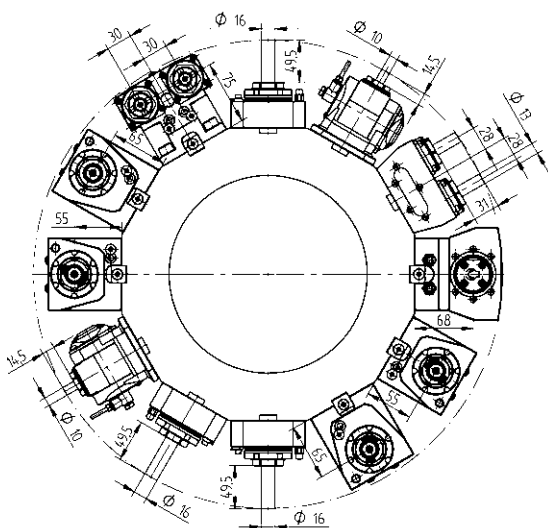

Portautensili Rotanti - QuickFlex®

Portautensili Rotanti - Estensione del programma



Portautensile rotante di foratura/fresatura

- ER-25 QF 420125022-55 1:1 EC
0067725000
- ER-25 QF 420125023-55 1:1 IC 80 bar
0067725000



Portautensile rotante di foratura/fresatura

- ER 32 410120002-55 1:1 EC
0067825000
- ER 32 410120003-55 1:1 IC 80 bar
0067825000



Portautensile rotante di foratura/fresatura, LF=55

- ER-25 QF 420525087-55 1:1 EC
0067725000
- ER-25 QF 420525088-55 1:1 IC 80 bar
0067725000



Portautensile rotante di fresatura

- Ø 22 410222002-55 1:1 EC
00675000483



Portautensile rotante di foratura/fresatura, LF=65

- ER-25 QF 420525085-55 1:1 EC
0067725000
- ER-25 QF 420525086-55 1:1 IC 80 bar
0067725000



Portautensile rotante di foratura/fresatura, disassato

- ER 25 410116027-55 1:1 EC
00675000932
- ER 25 410116028-55 1:1 IC 80 bar
00675000932
- ER 20 410113006-55 1:2 EC
00675000939
- ER 20 410113004-55 1:2 IC 80 bar
00675000939
- ER 16 410410000-55 1:3 EC
00675000937
- ER 16 410410001-55 1:3 IC 80 bar
00675000937
- ER 25 410116021-55 2:1 EC
00675000932
- ER 25 410116022-55 2:1 IC 80 bar
00675000932



Portautensile rotante radiale, per lavorazione su mandrino e contromandrino, LF=55

- ER-25 QF 420525069-55 1:1 EC
0067725000



Portautensile rotante radiale, per lavorazione su mandrino e contromandrino, LF=65

- ER-25 QF 420525077-55 1:1 EC
0067725000

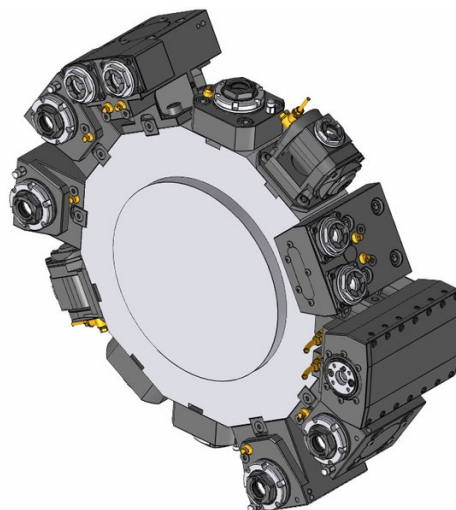
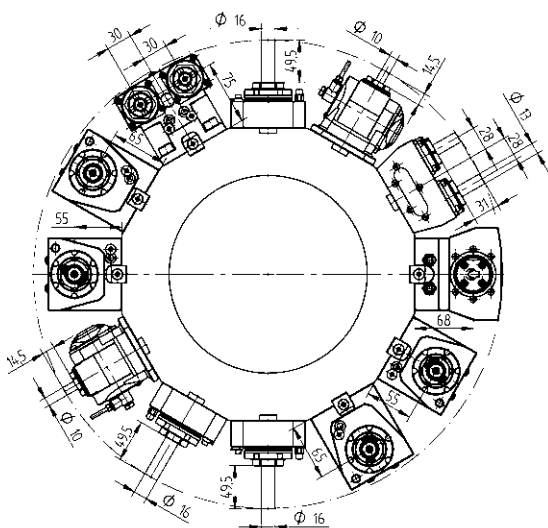

Portautensili Rotanti - Estensione del programma

Portautensili Rotanti - Estensione del programma



Portautensile rotante di foratura/fresatura, LF=65

ER 32	410520045-55 0067825000	1:1	EC
ER 32	410520046-55 0067825000	1:1	IC 80 bar
ER-20 QF	420520029-55 0067720001	1:2	EC
ER-20 QF	420520030-55 0067720001	1:2	IC 80 bar
ER 16	410810022-55 00675000841	1:3	EC
ER 16	410810023-55 00675000841	1:3	IC 80 bar
ER-25 QF	420525055-55 0067725000	2:1	EC
ER-25 QF	420525056-55 0067725000	2:1	IC 80 bar



Portautensile rotante orientabile di foratura/fresatura

ER 16	411010001-55 00675000902	1:1	EC
ER 16	411010002-55 00675000902	1:1	IC 80 bar
ER 11	411007003-55 00675000914	1:2	EC
ER 11	411007004-55 00675000914	1:2	IC 80 bar



Portautensile rotante di foratura/fresatura - doppio, asse Y

ER 20	413002001-55 00675000944	1:1	EC
--------------	-----------------------------	-----	----



Portautensile rotante di foratura/fresatura a 2 uscite, asse Y

ER 20	413502012-55 00675000944	1:1	EC
--------------	-----------------------------	-----	----



Portautensile rotante radiale portafrese combinato DIN6358, LF=65

Ø 22	410622013-55 00675000483	1:1	EC
Ø 22	410622007-55 00675000483	2:1	EC



Unità di brocciatura per interni ed esterni

TN765050	414532003-55	1:1	EC
-----------------	--------------	-----	----

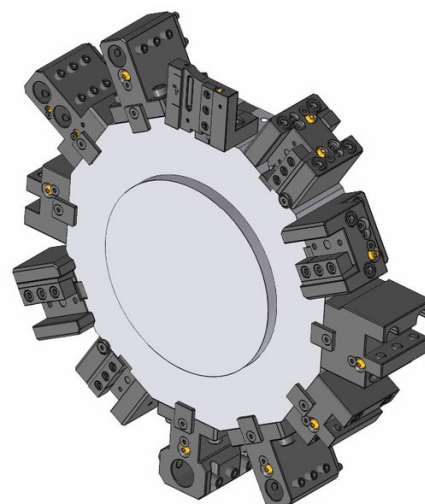
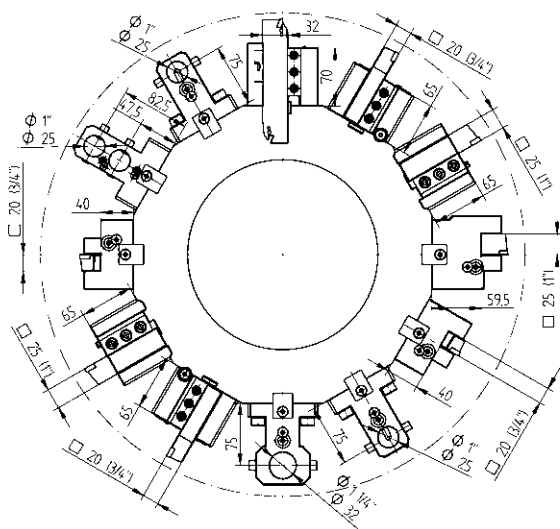

Portautensili statici - Programma standard

Portautensili statici - Estensione del programma



Portautensile

- 20 48-108585
- 25 48-106720



Portautensile, HP-IC

- 25 48-106720-HP IC 80 bar



Portautensile per lavorazione su mandrino e contromandrino

- 20 48-108460



Portautensile per esterni

- 20 48-108590



Portautensile per esterni

- 25 48-107758



Portautensile combinato

- Ø 25 48-107842 IC 80 bar
- Ø 32 48-106727 IC 80 bar

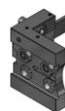

Portautensile da taglio

- SH 32 48-99637



Portautensile da taglio, HP-IC

- SH 32 48-102276R IC 80 bar
- SH 32 48-102276L IC 80 bar



Portautensile da taglio, con regolazione

- SH 32 48-110366 EC



Portautensile da taglio, con regolazione, HP-IC

- SH 32 48-109656R IC 80 bar
- 343-810100R87 IC 80 bar
- SH 32 48-109656L IC 80 bar
- 343-810100L87 IC 80 bar



Portautensile combinato, doppio

- Ø 25 48-108596 IC 80 bar

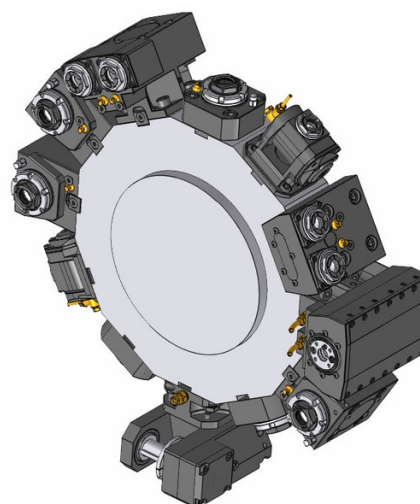
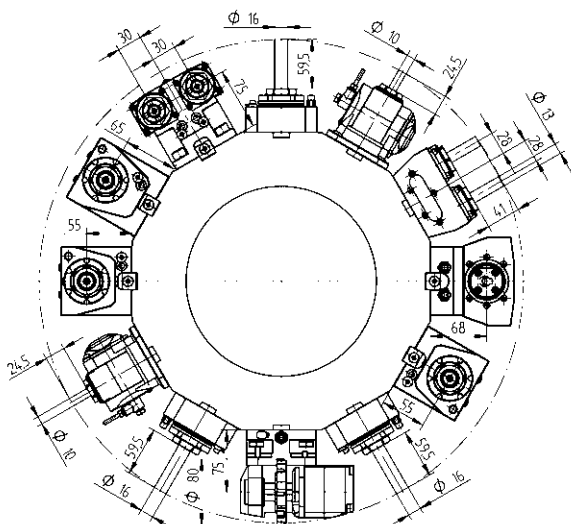

Portautensili Rotanti - QuickFlex®

Portautensili Rotanti - Estensione del programma



Portautensile rotante di foratura/fresatura

- ER-25 QF** 420125022-55 1:1 EC
0067725000
- ER-25 QF** 420125023-55 1:1 IC 80 bar
0067725000



Portautensile rotante di foratura/fresatura

- ER 32** 410120002-55 1:1 EC
0067825000
- ER 32** 410120003-55 1:1 IC 80 bar
0067825000



Portautensile rotante di foratura/fresatura, LF=55

- ER-25 QF** 420525087-55 1:1 EC
0067725000
- ER-25 QF** 420525088-55 1:1 IC 80 bar
0067725000



Portautensile rotante di fresatura

- Ø 22** 410222002-55 1:1 EC
00675000483



Portautensile rotante di foratura/fresatura, LF=65

- ER-25 QF** 420525085-55 1:1 EC
0067725000
- ER-25 QF** 420525086-55 1:1 IC 80 bar
0067725000



Portautensile rotante di foratura/fresatura, disassato

- ER 25** 410116027-55 1:1 EC
00675000932
- ER 25** 410116028-55 1:1 IC 80 bar
00675000932
- ER 20** 410113006-55 1:2 EC
00675000939
- ER 20** 410113004-55 1:2 IC 80 bar
00675000939
- ER 16** 410410000-55 1:3 EC
00675000937
- ER 16** 410410001-55 1:3 IC 80 bar
00675000937
- ER 25** 410116021-55 2:1 EC
00675000932
- ER 25** 410116022-55 2:1 IC 80 bar
00675000932



Portautensile rotante radiale, per lavorazione su mandrino e contromandrino, LF=55

- ER-25 QF** 420525069-55 1:1 EC
0067725000



Portautensile rotante radiale, per lavorazione su mandrino e contromandrino, LF=65

- ER-25 QF** 420525077-55 1:1 EC
0067725000

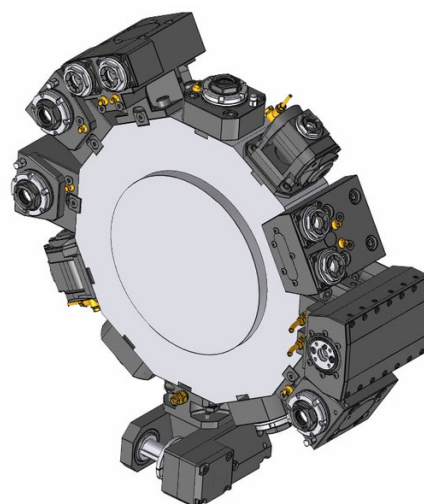
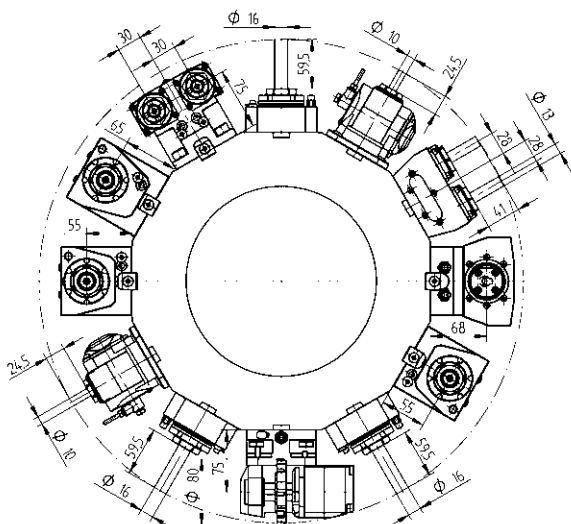

Portautensili Rotanti - Estensione del programma

Portautensili Rotanti - Estensione del programma



Portautensile rotante di foratura/fresatura, LF=65

ER 32	410520045-55 0067825000	1:1	EC
ER 32	410520046-55 0067825000	1:1	IC 80 bar
ER-20 QF	420520029-55 0067720001	1:2	EC
ER-20 QF	420520030-55 0067720001	1:2	IC 80 bar
ER 16	410810022-55 00675000841	1:3	EC
ER 16	410810023-55 00675000841	1:3	IC 80 bar
ER-25 QF	420525055-55 0067725000	2:1	EC
ER-25 QF	420525056-55 0067725000	2:1	IC 80 bar



Portautensile rotante radiale arretrato di foratura/fresatura, LF=65

ER 32	410520007-55 00675000592	1:1	EC
ER 32	410520008-55 00675000592	1:1	IC 80 bar
ER 32	410520009-55 00675000592	2:1	EC
ER 32	410520010-55 00675000592	2:1	IC 80 bar



Portautensile rotante orientabile di foratura/fresatura

ER 16	411010001-55 00675000902	1:1	EC
ER 16	411010002-55 00675000902	1:1	IC 80 bar
ER 11	411007003-55 00675000914	1:2	EC
ER 11	411007004-55 00675000914	1:2	IC 80 bar



Portautensile rotante radiale portafrese combinato DIN6358, LF=65

Ø 22	410622013-55 00675000483	1:1	EC
Ø 22	410622007-55 00675000483	2:1	EC

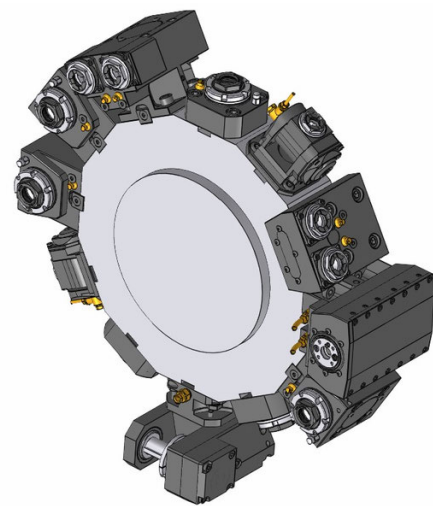
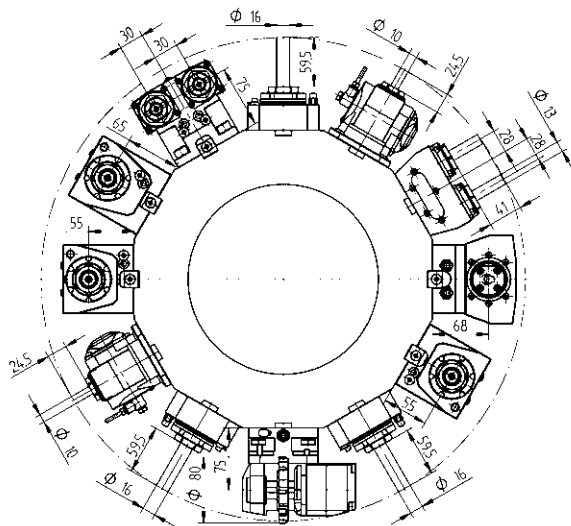

Portautensili Rotanti - Estensione del programma

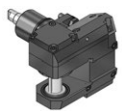

Portautensile rotante portafrese a disco

Tipo 14-2 411500000-55 2,73:1 EC

- 00675000489
- 160016142 Ø 16
- 160022142 Ø 22
- 160027142 Ø 27
- 160015142 Ø 5/8"
- 160019142 Ø 3/4"
- 160023142 Ø 7/8"
- 160025142 Ø 1"



Portautensile rotante di foratura/fresatura - doppio, asse Y

ER 20 413002001-55 1:1 EC

- 00675000944



Portautensile rotante di foratura/fresatura a 2 uscite, asse Y

ER 20 413502012-55 1:1 EC

- 00675000944



Unità di brocciatura per interni ed esterni

TN765050 414532003-55 1:1 EC

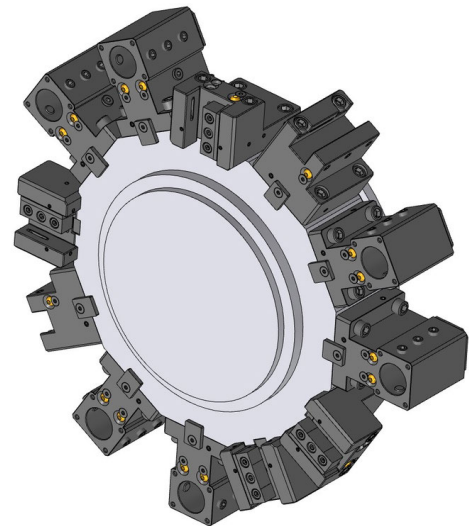
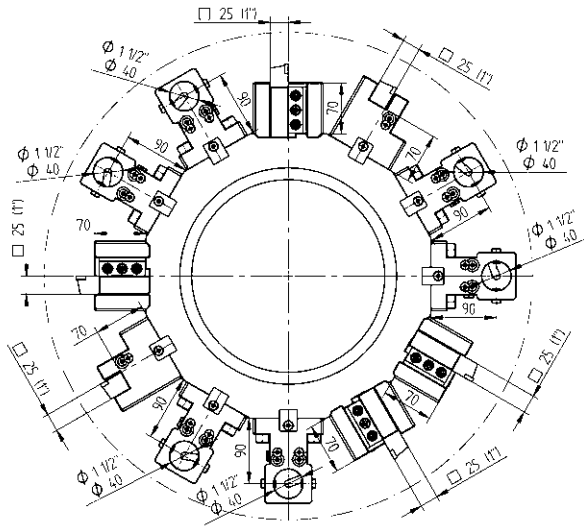

Portautensili statici - Programma standard

Portautensili statici - Estensione del programma



Portautensile, HP-IC

25 48-107657-HP IC 80 bar



Portautensile per lavorazione su mandrino e contromandrino, HP-IC

25 48-114828-HP IC 80 bar



Portautensile per esterni, HP-IC

25 48-113236-HP IC 80 bar



Portautensile combinato

Ø 40 48-107659
 241140020 ER32
 241140026 ER40



Portautensile da taglio

SH 32 48-100204



Portautensile da taglio, HP-IC

SH 32 48-102279R IC 80 bar
SH 32 48-102279L IC 80 bar

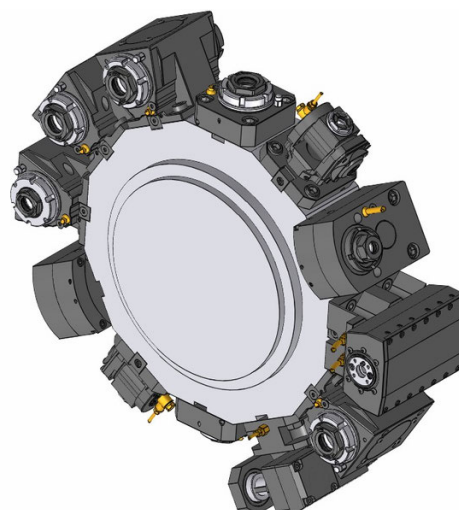
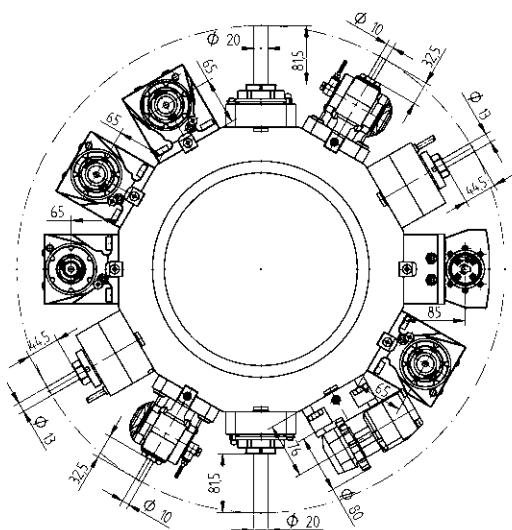

Portautensili Rotanti - QuickFlex®



Portautensile rotante di foratura/fresatura

- ER-32 QF 420132019-65 1:1 EC
0067732000
- ER-32 QF 420132020-65 1:1 IC 80 bar
0067732000



Portautensile rotante di foratura/fresatura

- ER-32 QF 420532025-65 1:1 EC
0067732000
- ER-32 QF 420532026-65 1:1 IC 80 bar
0067732000



Portautensile rotante di foratura/fresatura, per lavorazione su mandrino e contromandrino

- ER-32 QF 420532043-65 1:1 EC
0067732000

Portautensili Rotanti - Estensione del programma



Portautensile rotante di foratura/fresatura, disassato

- ER 32 410120030-65 1:1 EC
00675000958
- ER 32 410120031-65 1:1 IC 80 bar
00675000958
- ER 20 410113002-65 1:2 EC
00675000591
- ER 20 410113003-65 1:2 IC 80 bar
00675000591



Portautensile rotante di foratura/fresatura

- ER-25 QF 420525014-65 1:2 EC
0067725001
- ER-25 QF 420525015-65 1:2 IC 80 bar
0067725001
- ER-32 QF 420532031-65 2:1 EC
0067732000
- ER-32 QF 420532032-65 2:1 IC 80 bar
0067732000



Portautensile rotante orientabile di foratura/fresatura

- ER 16 411010000-65 1:1 EC
00675000902
- ER 16 411010001-65 1:1 IC 80 bar
00675000902
- ER 11 411007001-65 1:2 EC
00675000914
- ER 11 411007000-65 1:2 IC 80 bar
00675000914

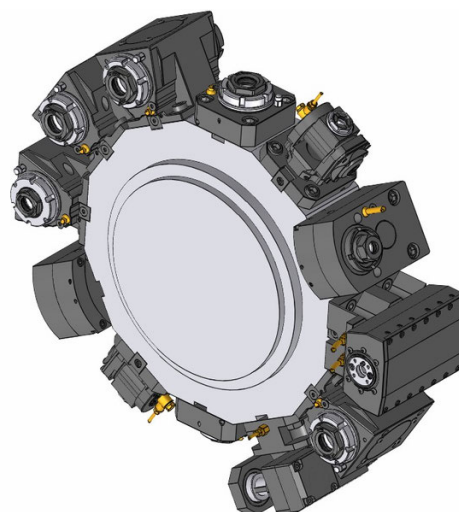
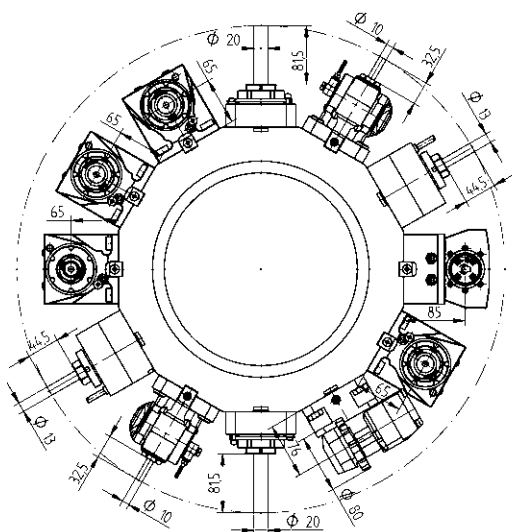



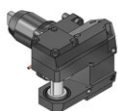





Portautensili Rotanti - Estensione del programma



Portautensile rotante disassato per frese a disco

Tipo 14-2 411500001-65 2,73:1 EC

-  00675000448
-  160016142 ϕ 16
-  160022142 ϕ 22
-  160027142 ϕ 27
-  160015142 ϕ 5/8"
-  160019142 ϕ 3/4"
-  160023142 ϕ 7/8"
-  160025142 ϕ 1"



Unità di brocciatura per interni ed esterni

TN765050 414532003-65 1:1 EC

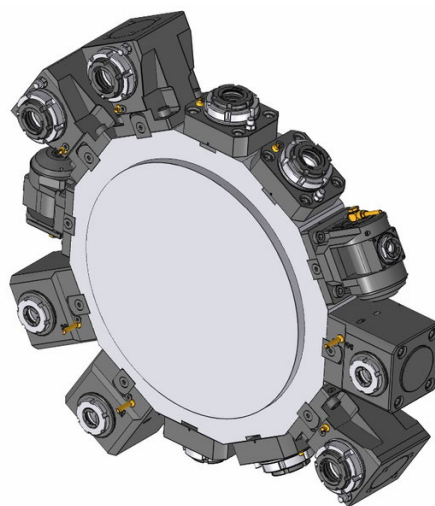
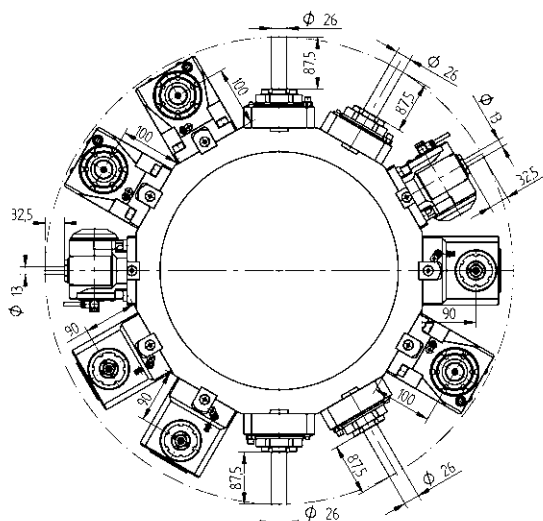

Portautensili Rotanti - QuickFlex®



Portautensile rotante di foratura/fresatura

- | | | | |
|-----------------|--------------|-----|-----------|
| ER-40 QF | 420140010-75 | 1:1 | EC |
| | 0067740000 | | |
| ER-40 QF | 420140011-75 | 1:1 | IC 80 bar |
| | 0067740000 | | |



Portautensile rotante di foratura/fresatura

- | | | | |
|-----------------|--------------|-----|-----------|
| ER-40 QF | 420540010-75 | 1:1 | EC |
| | 0067740000 | | |
| ER-40 QF | 420540011-75 | 1:1 | IC 80 bar |
| | 0067740000 | | |

Portautensili Rotanti - Estensione del programma



Portautensile rotante di foratura/fresatura

- | | | | |
|--------------|--------------|-----|-----------|
| ER 25 | 410516000-75 | 1:2 | EC |
| | 00675000897 | | |
| ER 25 | 410516001-75 | 1:2 | IC 80 bar |
| | 00675000897 | | |



Portautensile rotante orientabile di foratura/fresatura

- | | | | |
|--------------|--------------|-----|-----------|
| ER 20 | 411013000-75 | 1:1 | EC |
| | 00675000928 | | |
| ER 20 | 411013001-75 | 1:1 | IC 80 bar |
| | 00675000928 | | |
| ER 16 | 411010000-75 | 1:2 | EC |
| | 00675000936 | | |
| ER 16 | 411010001-75 | 1:2 | IC 80 bar |
| | 00675000936 | | |

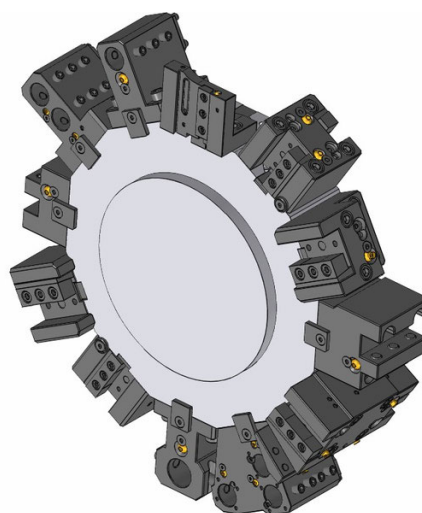
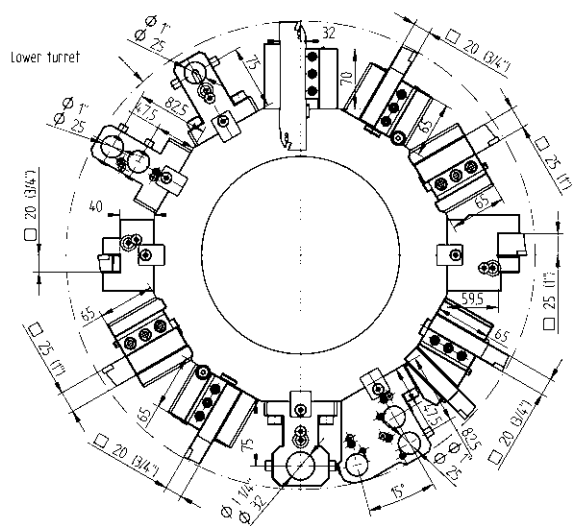

Portautensili statici - Programma standard



Portautensile
 20 48-108585
 25 48-106720



Portautensile, HP-IC
 25 48-106720-HP IC 80 bar



Portautensile per lavorazione su mandrino e contromandrino
 20 48-108460



Portautensile per esterni
 20 48-108590



Portautensile per esterni
 25 48-107758



Portautensile combinato
 Ø 25 48-107842 IC 80 bar
 Ø 32 48-106727 IC 80 bar

Portautensili statici - Estensione del programma



Portautensile doppio, 24 stazioni (solo per torretta SW340)
 20 48-108592 EC



Portautensile per lavorazione su mandrino e contromandrino, doppio, 24 stazioni (solo per torretta SW340)
 20 48-108461 EC



Portautensile da taglio
 SH 32 48-99637



Portautensile da taglio, HP-IC
 SH 32 48-102276R IC 80 bar
 SH 32 48-102276L IC 80 bar



Portautensile da taglio, con regolazione, HP-IC
 SH 32 48-109656R IC 80 bar
 343-810100R87
 SH 32 48-109656L IC 80 bar
 343-810100L87



Portautensile combinato, doppio
 Ø 25 48-108596 IC 80 bar



Portautensile combinato, universale, triplo, 24 stazioni (solo per torretta SW340)
 Ø 25 48-108462 IC 80 bar

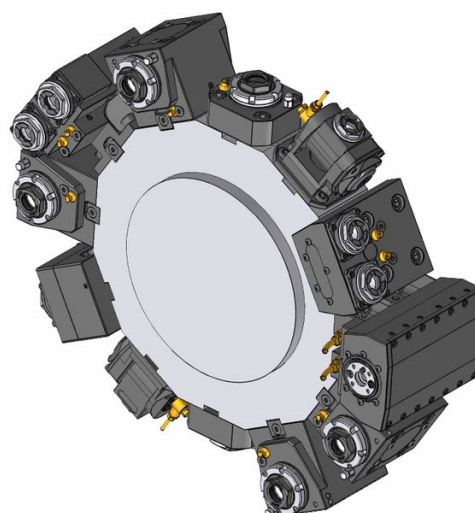
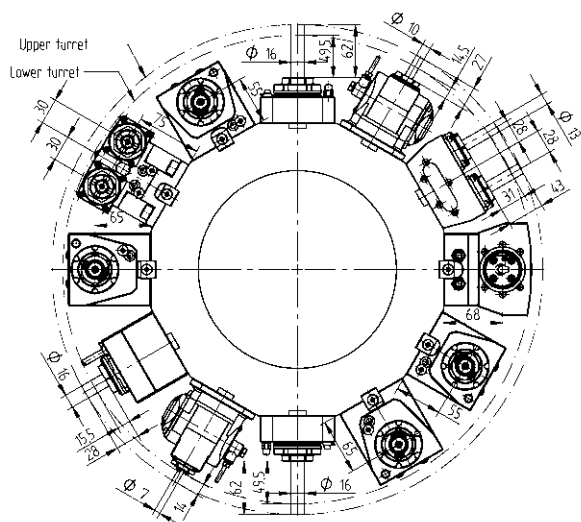

Portautensili Rotanti - QuickFlex®

Portautensili Rotanti - Estensione del programma



Portautensile rotante di foratura/fresatura

- ER-25 QF 420125022-55 1:1 EC
0067725000
- ER-25 QF 420125023-55 1:1 IC 80 bar
0067725000



Portautensile rotante di foratura/fresatura

- ER 32 410120002-55 1:1 EC
0067825000
- ER 32 410120003-55 1:1 IC 80 bar
0067825000



Portautensile rotante di foratura/fresatura, LF=55

- ER-25 QF 420525087-55 1:1 EC
0067725000
- ER-25 QF 420525088-55 1:1 IC 80 bar
0067725000



Portautensile rotante di fresatura

- Ø 22 410222002-55 1:1 EC
00675000483



Portautensile rotante di foratura/fresatura, LF=65

- ER-25 QF 420525085-55 1:1 EC
0067725000
- ER-25 QF 420525086-55 1:1 IC 80 bar
0067725000



Portautensile rotante di foratura/fresatura, disassato

- ER 25 410116027-55 1:1 EC
00675000932
- ER 25 410116028-55 1:1 IC 80 bar
00675000932
- ER 20 410113006-55 1:2 EC
00675000939
- ER 20 410113004-55 1:2 IC 80 bar
00675000939
- ER 16 410410000-55 1:3 EC
00675000937
- ER 16 410410001-55 1:3 IC 80 bar
00675000937
- ER 25 410116021-55 2:1 EC
00675000932
- ER 25 410116022-55 2:1 IC 80 bar
00675000932



Portautensile rotante radiale, per lavorazione su mandrino e contromandrino, LF=55

- ER-25 QF 420525069-55 1:1 EC
0067725000



Portautensile rotante radiale, per lavorazione su mandrino e contromandrino, LF=65

- ER-25 QF 420525077-55 1:1 EC
0067725000

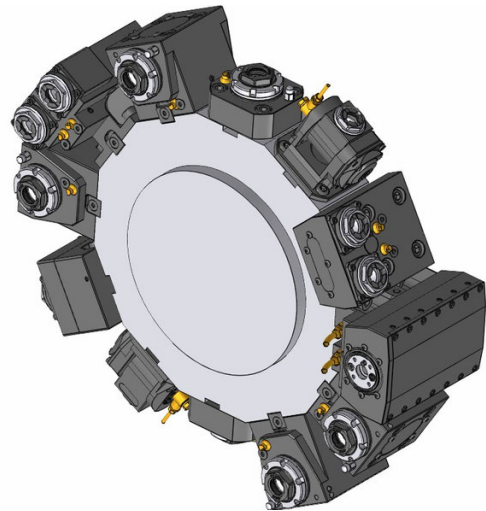
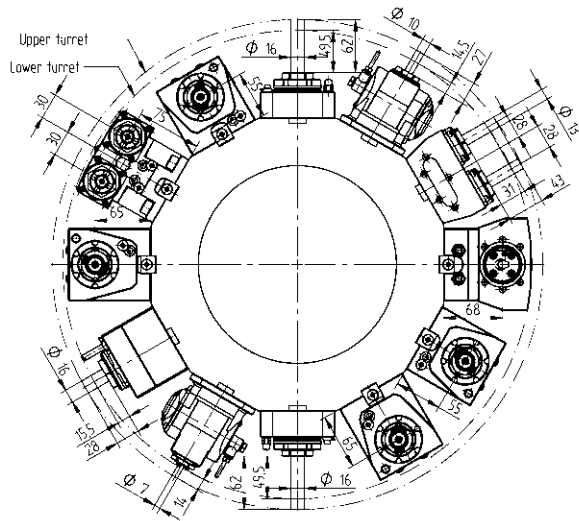

Portautensili Rotanti - Estensione del programma

Portautensili Rotanti - Estensione del programma



Portautensile rotante di foratura/fresatura, LF=65

ER 32	410520045-55 0067825000	1:1	EC
ER 32	410520046-55 0067825000	1:1	IC 80 bar
ER-20 QF	420520029-55 0067720001	1:2	EC
ER-20 QF	420520030-55 0067720001	1:2	IC 80 bar
ER 16	410810022-55 00675000841	1:3	EC
ER 16	410810023-55 00675000841	1:3	IC 80 bar
ER-25 QF	420525055-55 0067725000	2:1	EC
ER-25 QF	420525056-55 0067725000	2:1	IC 80 bar



Portautensile rotante radiale portafrese combinato DIN6358, LF=65

Ø 22	410622013-55 00675000483	1:1	EC
Ø 22	410622007-55 00675000483	2:1	EC



Portautensile rotante orientabile di foratura/fresatura

ER 16	411010001-55 00675000902	1:1	EC
ER 16	411010002-55 00675000902	1:1	IC 80 bar
ER 11	411007003-55 00675000914	1:2	EC
ER 11	411007004-55 00675000914	1:2	IC 80 bar



Portautensile rotante di foratura/fresatura - doppio, asse Y

ER 20	413002001-55 00675000944	1:1	EC
--------------	-----------------------------	-----	----



Portautensile rotante di foratura/fresatura a 2 uscite, asse Y

ER 20	413502012-55 00675000944	1:1	EC
--------------	-----------------------------	-----	----



Unità di brocciatura per interni ed esterni

TN765050	414532003-55	1:1	EC
-----------------	--------------	-----	----

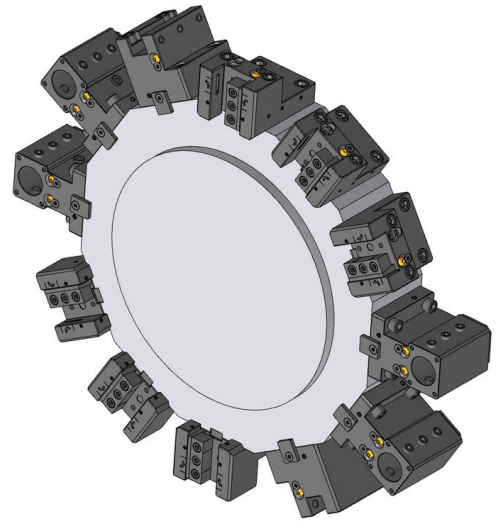
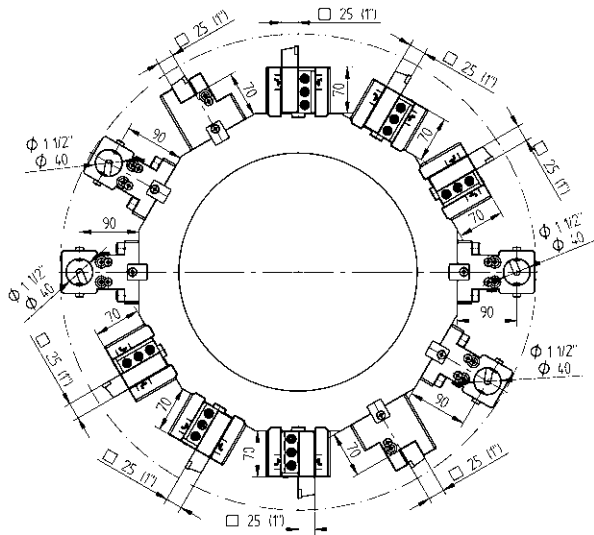

Portautensili statici - Programma standard

Portautensili statici - Estensione del programma



25 Portautensile, HP-IC 48-107657-HP IC 80 bar



25 Portautensile per lavorazione su mandrino e contromandrino, HP-IC 48-114828-HP IC 80 bar



25 Portautensile per esterni, HP-IC 48-113236-HP IC 80 bar



Ø 40 Portautensile combinato 48-107659
 241140020 ER32
 241140026 ER40



SH 32 Portautensile da taglio 48-100204



SH 32 Portautensile da taglio, HP-IC 48-102279R IC 80 bar
SH 32 48-102279L IC 80 bar

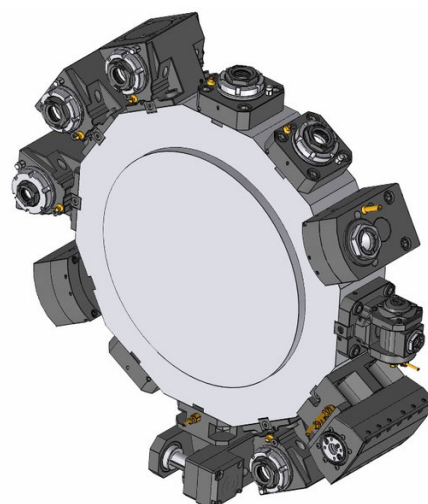
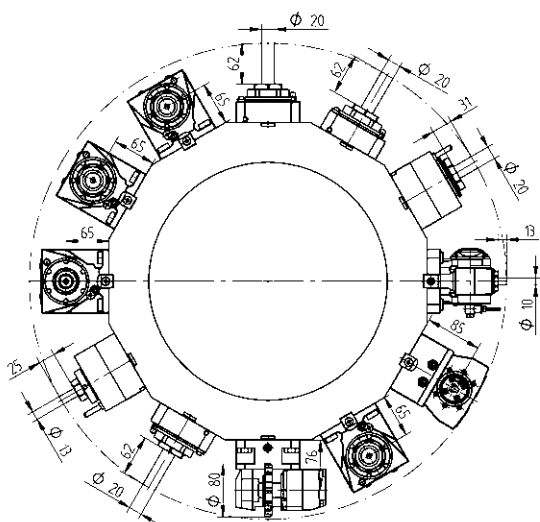

Portautensili Rotanti - QuickFlex®



Portautensile rotante di foratura/fresatura

- ER-32 QF** 420132019-65 1:1 EC
0067732000
- ER-32 QF** 420132020-65 1:1 IC 80 bar
0067732000



Portautensile rotante di foratura/fresatura

- ER-32 QF** 420532025-65 1:1 EC
0067732000
- ER-32 QF** 420532026-65 1:1 IC 80 bar
0067732000



Portautensile rotante di foratura/fresatura, per lavorazione su mandrino e contromandrino

- ER-32 QF** 420532043-65 1:1 EC
0067732000

Portautensili Rotanti - Estensione del programma



Portautensile rotante di foratura/fresatura, disassato

- ER 32** 410120030-65 1:1 EC
00675000958
- ER 32** 410120031-65 1:1 IC 80 bar
00675000958
- ER 20** 410113002-65 1:2 EC
00675000591
- ER 20** 410113003-65 1:2 IC 80 bar
00675000591



Portautensile rotante di foratura/fresatura

- ER-25 QF** 420525014-65 1:2 EC
0067725001
- ER-25 QF** 420525015-65 1:2 IC 80 bar
0067725001
- ER-32 QF** 420532031-65 2:1 EC
0067732000
- ER-32 QF** 420532032-65 2:1 IC 80 bar
0067732000



Portautensile rotante orientabile di foratura/fresatura

- ER 16** 411010000-65 1:1 EC
00675000902
- ER 16** 411010001-65 1:1 IC 80 bar
00675000902
- ER 11** 411007001-65 1:2 EC
00675000914
- ER 11** 411007000-65 1:2 IC 80 bar
00675000914

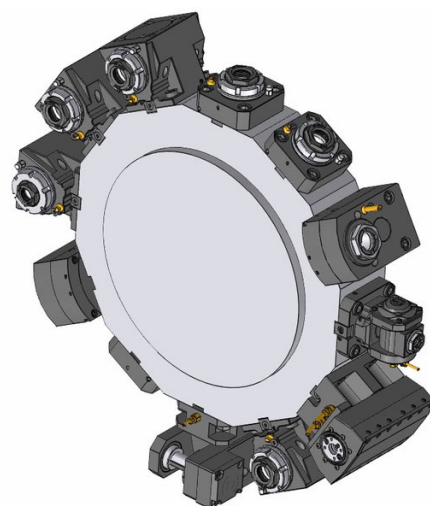
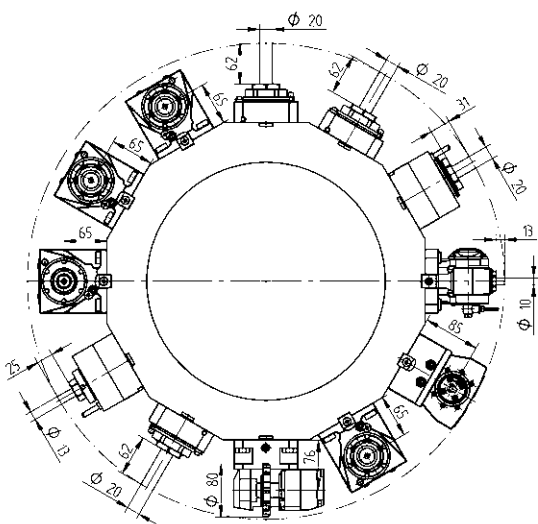

Portautensili Rotanti - Estensione del programma

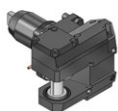

Portautensile rotante disassato per frese a disco

Tipo 14-2 411500001-65 2,73:1 EC

00675000448

 160016142 Ø 16

 160022142 Ø 22

 160027142 Ø 27

 160015142 Ø 5/8"

 160019142 Ø 3/4"

 160023142 Ø 7/8"

 160025142 Ø 1"



Unità di brocciatura per interni ed esterni

TN765050 414532003-65 1:1 EC

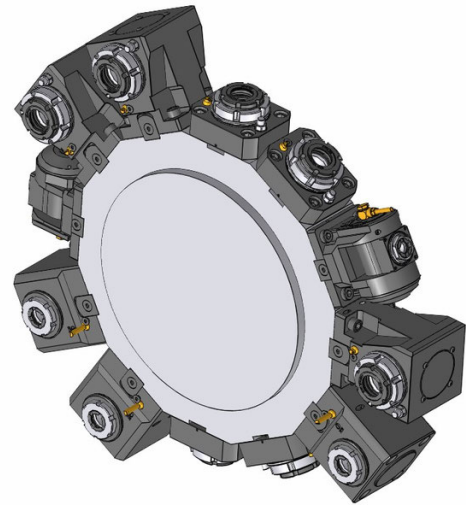
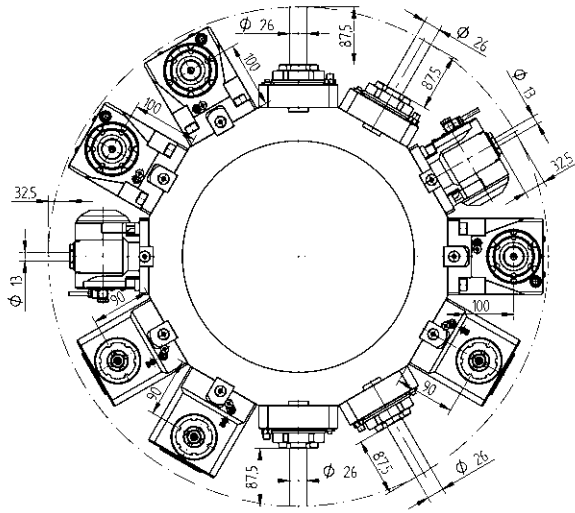

Portautensili Rotanti - QuickFlex®



Portautensile rotante di foratura/fresatura

- | | | | |
|-----------------|--------------|-----|-----------|
| ER-40 QF | 420140010-75 | 1:1 | EC |
| | 0067740000 | | |
| ER-40 QF | 420140011-75 | 1:1 | IC 80 bar |
| | 0067740000 | | |



Portautensile rotante di foratura/fresatura

- | | | | |
|-----------------|--------------|-----|-----------|
| ER-40 QF | 420540010-75 | 1:1 | EC |
| | 0067740000 | | |
| ER-40 QF | 420540011-75 | 1:1 | IC 80 bar |
| | 0067740000 | | |

Portautensili Rotanti - Estensione del programma



Portautensile rotante di foratura/fresatura

- | | | | |
|--------------|--------------|-----|-----------|
| ER 25 | 410516000-75 | 1:2 | EC |
| | 00675000897 | | |
| ER 25 | 410516001-75 | 1:2 | IC 80 bar |
| | 00675000897 | | |



Portautensile rotante orientabile di foratura/fresatura

- | | | | |
|--------------|--------------|-----|-----------|
| ER 20 | 411013000-75 | 1:1 | EC |
| | 00675000928 | | |
| ER 20 | 411013001-75 | 1:1 | IC 80 bar |
| | 00675000928 | | |
| ER 16 | 411010000-75 | 1:2 | EC |
| | 00675000936 | | |
| ER 16 | 411010001-75 | 1:2 | IC 80 bar |
| | 00675000936 | | |

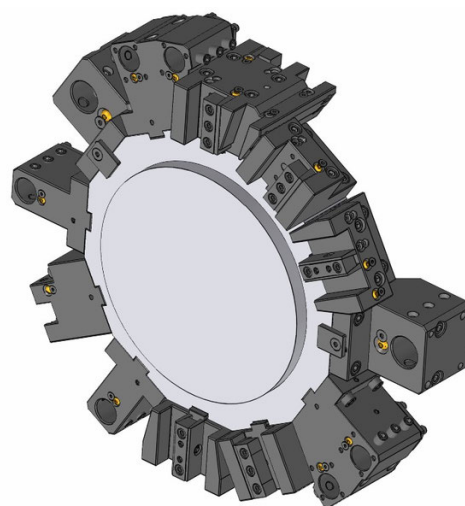
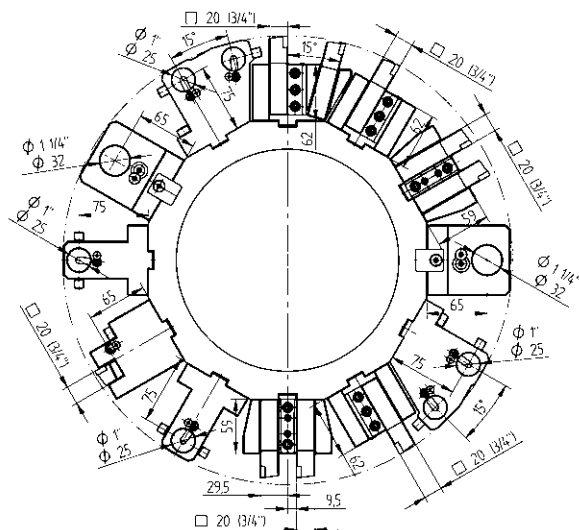

Portautensili statici - Programma standard

Portautensili statici - Estensione del programma



Portautensile
48-101470



Portautensile, HP-IC
48-101470-HP IC 80 bar



Portautensile per lavorazione su mandrino e contromandrino
48-101471



Portautensile per esterni
48-102352



Portautensile combinato, LF=75
Ø 25 48-101472



Portautensile combinato
Ø 32 48-107155



Portautensile doppio, asse Y
48-101473



Portautensile per lavorazione su mandrino e contromandrino, doppio, 24 stazioni (solo per torretta SW300)
48-107973 EC



Portautensile da taglio
SH 26 48-100419



Portautensile da taglio, HP-IC
SH 26 48-102274R IC 80 bar

SH 26 48-102274L IC 80 bar

SH 32 48-112233R IC 80 bar

343-810100R95

SH 32 48-112233L IC 80 bar

343-810100L95



Portautensile combinato, universale, doppio, 24 stazioni (solo per torretta SW300)
Ø 25 48-107985 IC 80 bar

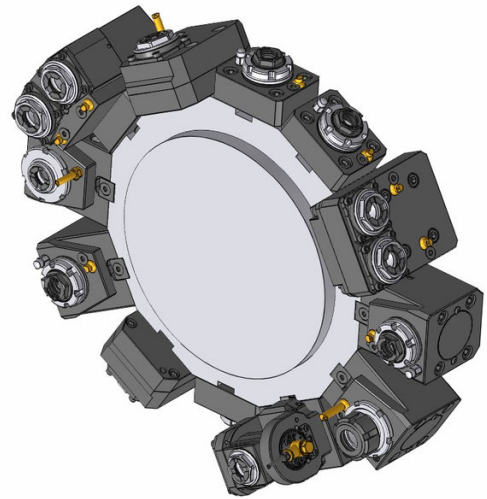
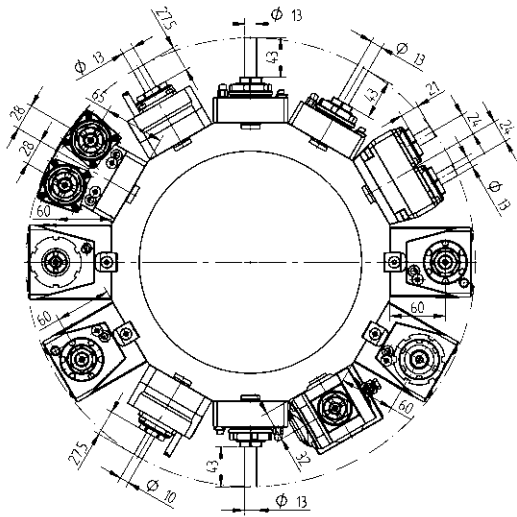

Portautensili Rotanti - QuickFlex®

Portautensili Rotanti - Estensione del programma



Portautensile rotante di foratura/fresatura

- | | | | |
|-----------------|--------------|-----|-----------|
| ER-20 QF | 420120010-44 | 1:1 | EC |
| | 0067720000 | | |
| ER-20 QF | 420120011-44 | 1:1 | IC 80 bar |
| | 0067720000 | | |



Portautensile rotante di foratura/fresatura

- | | | | |
|--------------|--------------|-----|-----------|
| ER 25 | 410116004-44 | 1:1 | EC |
| | 00675000720 | | |
| ER 25 | 410116002-44 | 1:1 | IC 80 bar |
| | 00675000720 | | |



Portautensile rotante di foratura/fresatura, LF=60

- | | | | |
|-----------------|--------------|-----|-----------|
| ER-20 QF | 420520010-44 | 1:1 | EC |
| | 0067720000 | | |
| ER-20 QF | 420520011-44 | 1:1 | IC 80 bar |
| | 0067720000 | | |



Portautensile rotante di foratura/fresatura, disassato

- | | | | |
|--------------|--------------|-------|----|
| ER 20 | 410113004-44 | 1:2 | EC |
| | 00675000939 | | |
| ER 16 | 410110002-44 | 1:3 | EC |
| | 00675000937 | | |
| ER 25 | 410116005-44 | 1,5:1 | EC |
| | 00675000932 | | |



Portautensile rotante radiale, per lavorazione su mandrino e contromandrino, LF=60

- | | | | |
|-----------------|--------------|-----|----|
| ER-20 QF | 420520012-44 | 1:1 | EC |
| | 0067720000 | | |

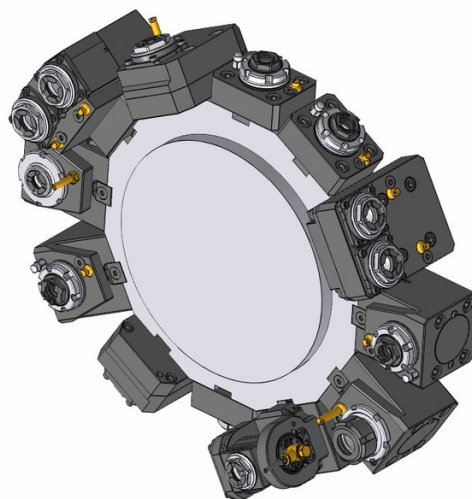
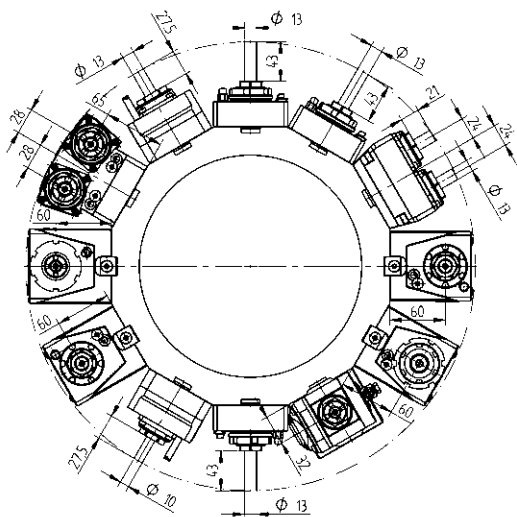

Portautensili Rotanti - Estensione del programma

Portautensili Rotanti - Estensione del programma



Portautensile rotante di foratura/fresatura, LF=60

ER 25	410516005-44 00675000720	1:1	EC
ER 25	410516006-44 00675000720	1:1	IC 80 bar
ER 20	410513002-44 00675000833	1:2	EC
ER 20	410513003-44 00675000833	1:2	IC 80 bar
ER 16	410810006-44 00675000841	1:3	EC
ER 16	410810007-44 00675000841	1:3	IC 80 bar
ER 25	410516002-44 00675000720	2:1	EC
ER 25	410516003-44 00675000720	2:1	IC 80 bar



Portautensile rotante orientabile di foratura/fresatura, LF=32

ER 16	411010004-44 00675000902	1:1	EC
ER 16	411010005-44 00675000902	1:1	IC 80 bar
ER 11	411007006-44 00675000914	1:2	EC
ER 11	411007007-44 00675000914	1:2	IC 80 bar



Portautensile rotante di foratura/fresatura - doppio, asse Y

ER 20	413002003-44 00675000939	1:1	EC
ER 20	413002004-44 00675000939	1:1	IC 80 bar



Portautensile rotante radiale portafrese combinato DIN6358, LF=60

Ø 22	410622000-44 00675000483	1:1	EC
Ø 22	410622001-44 00675000483	2:1	EC



Portautensile rotante di foratura/fresatura a 2 uscite, asse Y

ER 20	413502004-44 00675000939	1:1	EC
ER 20	413502005-44 00675000939	1:1	IC 80 bar

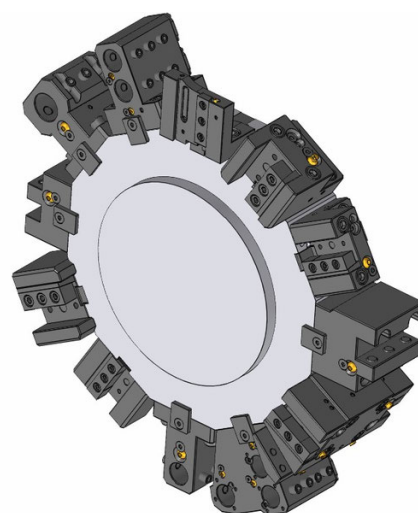
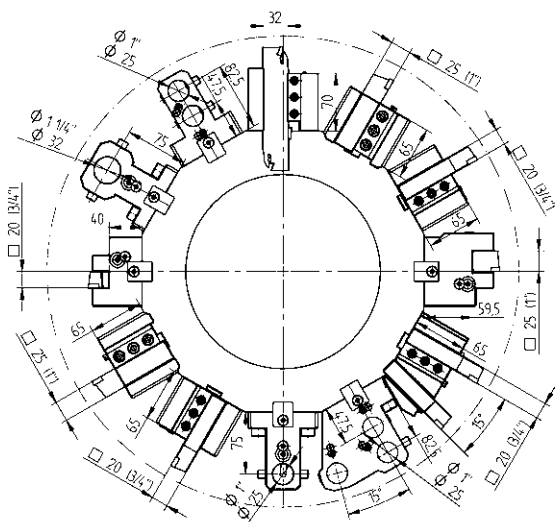

Portautensili statici - Programma standard

Portautensili statici - Estensione del programma



Portautensile
 20 48-108585
 25 48-106720



Portautensile, HP-IC
 25 48-106720-HP IC 80 bar



Portautensile per lavorazione su mandrino e contromandrino
 20 48-108460



Portautensile per esterni
 20 48-108590



Portautensile per esterni
 25 48-107758



Portautensile combinato
 Ø 25 48-107842 IC 80 bar
 Ø 32 48-106727 IC 80 bar



Portautensile doppio, 24 stazioni (solo per torretta SW340)
 20 48-108592 EC



Portautensile per lavorazione su mandrino e contromandrino, doppio, 24 stazioni (solo per torretta SW340)
 20 48-108461 EC



Portautensile da taglio
 SH 32 48-99637



Portautensile da taglio, HP-IC
 SH 32 48-102276R IC 80 bar
 SH 32 48-102276L IC 80 bar



Portautensile da taglio, con regolazione, HP-IC
 SH 32 48-109656R IC 80 bar
 343-810100R87
 SH 32 48-109656L IC 80 bar
 343-810100L87

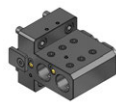

Portautensile combinato, doppio
 Ø 25 48-108596 IC 80 bar



Portautensile combinato, universale, triplo, 24 stazioni (solo per torretta SW340)
 Ø 25 48-108462 IC 80 bar

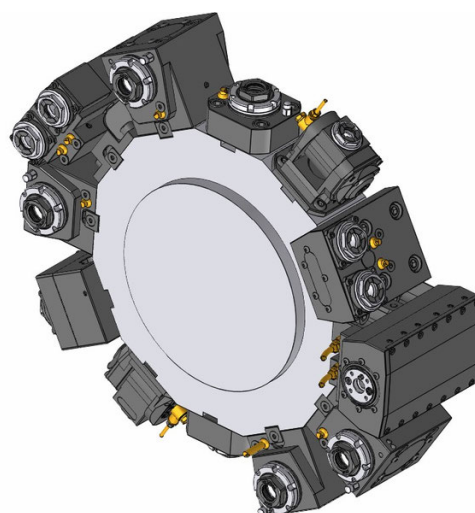
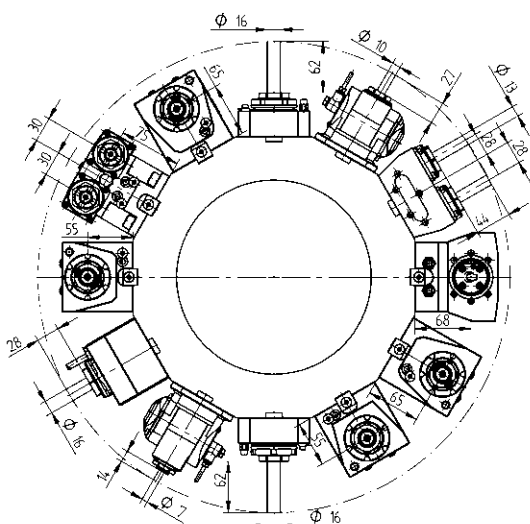

Portautensili Rotanti - QuickFlex®

Portautensili Rotanti - Estensione del programma



Portautensile rotante di foratura/fresatura

- | | | | |
|-----------------|--------------|-----|-----------|
| ER-25 QF | 420125022-55 | 1:1 | EC |
| | 0067725000 | | |
| ER-25 QF | 420125023-55 | 1:1 | IC 80 bar |
| | 0067725000 | | |



Portautensile rotante di foratura/fresatura

- | | | | |
|--------------|--------------|-----|-----------|
| ER 32 | 410120002-55 | 1:1 | EC |
| | 0067825000 | | |
| ER 32 | 410120003-55 | 1:1 | IC 80 bar |
| | 0067825000 | | |



Portautensile rotante di foratura/fresatura, LF=55

- | | | | |
|-----------------|--------------|-----|-----------|
| ER-25 QF | 420525087-55 | 1:1 | EC |
| | 0067725000 | | |
| ER-25 QF | 420525088-55 | 1:1 | IC 80 bar |
| | 0067725000 | | |



Portautensile rotante di fresatura

- | | | | |
|-------------|--------------|-----|----|
| Ø 22 | 410222002-55 | 1:1 | EC |
| | 00675000483 | | |



Portautensile rotante di foratura/fresatura, LF=65

- | | | | |
|-----------------|--------------|-----|-----------|
| ER-25 QF | 420525085-55 | 1:1 | EC |
| | 0067725000 | | |
| ER-25 QF | 420525086-55 | 1:1 | IC 80 bar |
| | 0067725000 | | |



Portautensile rotante di foratura/fresatura, disassato

- | | | | |
|--------------|--------------|-----|-----------|
| ER 25 | 410116027-55 | 1:1 | EC |
| | 00675000932 | | |
| ER 25 | 410116028-55 | 1:1 | IC 80 bar |
| | 00675000932 | | |
| ER 20 | 410113006-55 | 1:2 | EC |
| | 00675000939 | | |
| ER 20 | 410113004-55 | 1:2 | IC 80 bar |
| | 00675000939 | | |
| ER 16 | 410410000-55 | 1:3 | EC |
| | 00675000937 | | |
| ER 16 | 410410001-55 | 1:3 | IC 80 bar |
| | 00675000937 | | |
| ER 25 | 410116021-55 | 2:1 | EC |
| | 00675000932 | | |
| ER 25 | 410116022-55 | 2:1 | IC 80 bar |
| | 00675000932 | | |



Portautensile rotante radiale, per lavorazione su mandrino e contromandrino, LF=55

- | | | | |
|-----------------|--------------|-----|----|
| ER-25 QF | 420525069-55 | 1:1 | EC |
| | 0067725000 | | |



Portautensile rotante radiale, per lavorazione su mandrino e contromandrino, LF=65

- | | | | |
|-----------------|--------------|-----|----|
| ER-25 QF | 420525077-55 | 1:1 | EC |
| | 0067725000 | | |

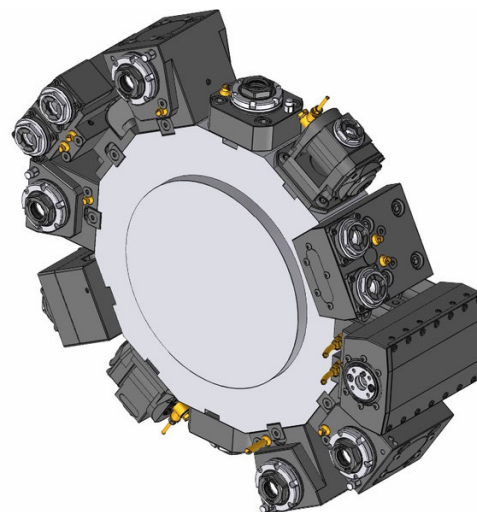
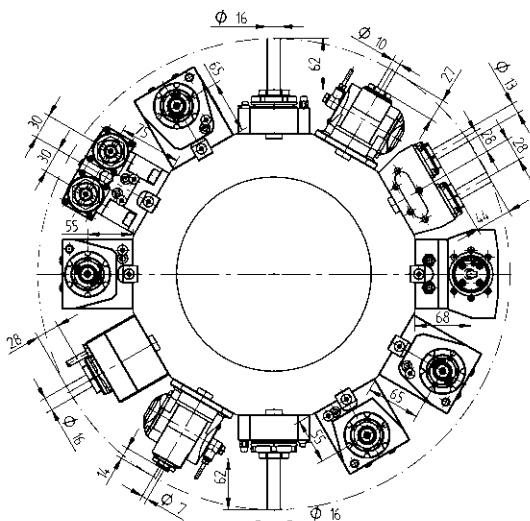

Portautensili Rotanti - Estensione del programma

Portautensili Rotanti - Estensione del programma



Portautensile rotante di foratura/fresatura, LF=65

ER 32	410520045-55 0067825000	1:1	EC
ER 32	410520046-55 0067825000	1:1	IC 80 bar
ER-20 QF	420520029-55 0067720001	1:2	EC
ER-20 QF	420520030-55 0067720001	1:2	IC 80 bar
ER 16	410810022-55 00675000841	1:3	EC
ER 16	410810023-55 00675000841	1:3	IC 80 bar
ER-25 QF	420525055-55 0067725000	2:1	EC
ER-25 QF	420525056-55 0067725000	2:1	IC 80 bar



Portautensile rotante radiale portafrese combinato DIN6358, LF=65

Ø 22	410622013-55 00675000483	1:1	EC
Ø 22	410622007-55 00675000483	2:1	EC



Portautensile rotante radiale arretrato di foratura/fresatura, LF=65

ER 32	410520007-55 00675000592	1:1	EC
ER 32	410520008-55 00675000592	1:1	IC 80 bar
ER 32	410520009-55 00675000592	2:1	EC
ER 32	410520010-55 00675000592	2:1	IC 80 bar



Portautensile rotante orientabile di foratura/fresatura

ER 16	411010001-55 00675000902	1:1	EC
ER 16	411010002-55 00675000902	1:1	IC 80 bar
ER 11	411007003-55 00675000914	1:2	EC
ER 11	411007004-55 00675000914	1:2	IC 80 bar

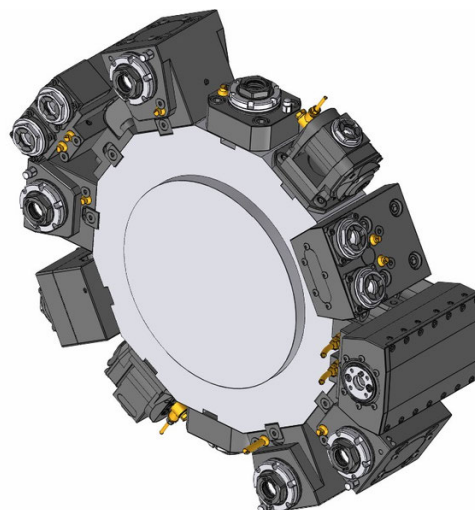
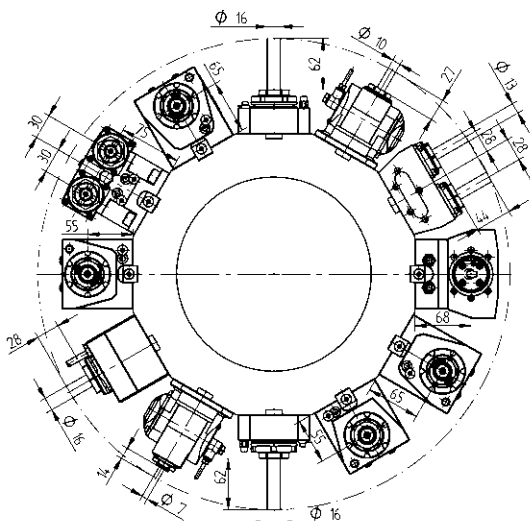

Portautensili Rotanti - Estensione del programma

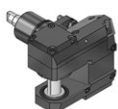

Portautensile rotante portafrese a disco

Tipo 14-2 411500000-55 2,73:1 EC

- 00675000489
- 160016142 Ø 16
- 160022142 Ø 22
- 160027142 Ø 27
- 160015142 Ø 5/8"
- 160019142 Ø 3/4"
- 160023142 Ø 7/8"
- 160025142 Ø 1"



Portautensile rotante di foratura/fresatura - doppio, asse Y

ER 20 413002001-55 1:1 EC

- 00675000944



Portautensile rotante di foratura/fresatura a 2 uscite, asse Y

ER 20 413502012-55 1:1 EC

- 00675000944



Unità di brocciatura per interni ed esterni

TN765050 414532003-55 1:1 EC

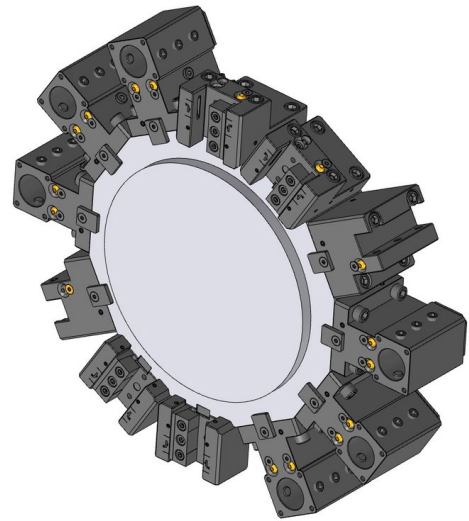
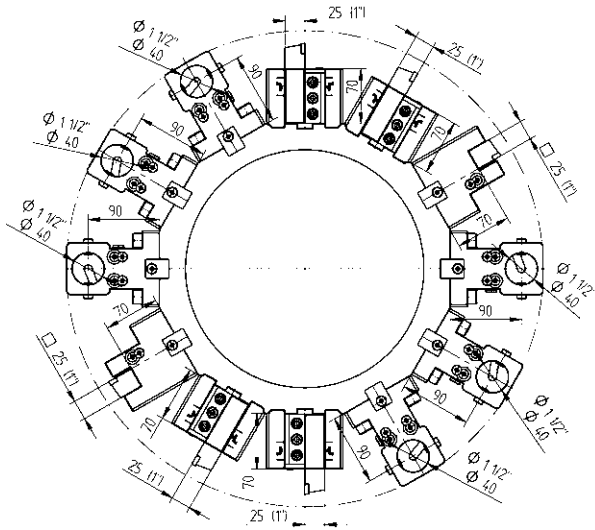

Portautensili statici - Programma standard



25 Portautensile, HP-IC
48-107657-HP IC 80 bar



25 Portautensile per lavorazione su mandrino e contromandrino, HP-IC
48-114828-HP IC 80 bar



25 Portautensile per esterni, HP-IC
48-113236-HP IC 80 bar



Ø 40 Portautensile combinato
48-107659
241140020 ER32
241140026 ER40

Portautensili statici - Estensione del programma



SH 32 Portautensile da taglio
48-100204



SH 32 Portautensile da taglio, HP-IC
48-102279R IC 80 bar
48-102279L IC 80 bar

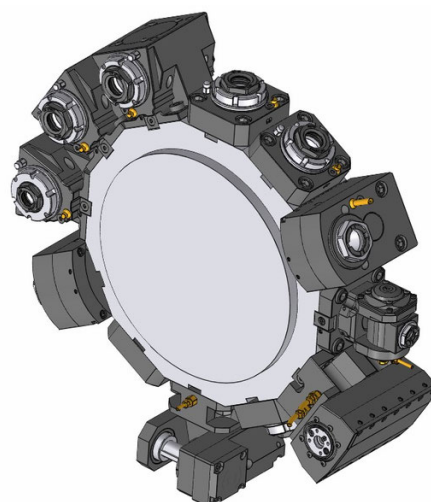
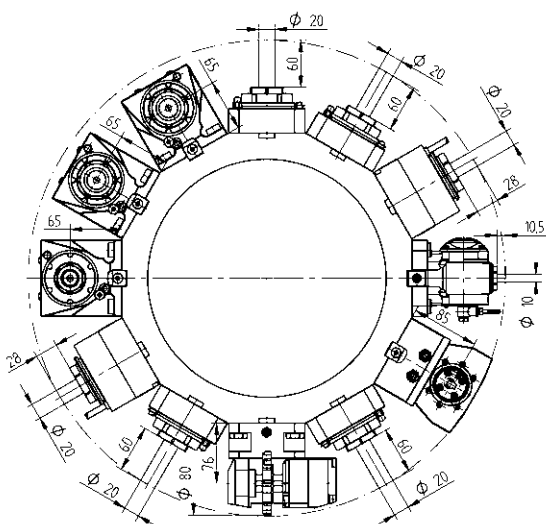

Portautensili Rotanti - QuickFlex®



Portautensile rotante di foratura/fresatura

- ER-32 QF 420132019-65 1:1 EC
0067732000
- ER-32 QF 420132020-65 1:1 IC 80 bar
0067732000



Portautensile rotante di foratura/fresatura

- ER-32 QF 420532025-65 1:1 EC
0067732000
- ER-32 QF 420532026-65 1:1 IC 80 bar
0067732000



Portautensile rotante di foratura/fresatura, per lavorazione su mandrino e contromandrino

- ER-32 QF 420532043-65 1:1 EC
0067732000

Portautensili Rotanti - Estensione del programma



Portautensile rotante di foratura/fresatura, disassato

- ER 32 410120030-65 1:1 EC
00675000958
- ER 32 410120031-65 1:1 IC 80 bar
00675000958
- ER 20 410113002-65 1:2 EC
00675000591
- ER 20 410113003-65 1:2 IC 80 bar
00675000591



Portautensile rotante di foratura/fresatura

- ER-25 QF 420525014-65 1:2 EC
0067725001
- ER-25 QF 420525015-65 1:2 IC 80 bar
0067725001
- ER-32 QF 420532031-65 2:1 EC
0067732000
- ER-32 QF 420532032-65 2:1 IC 80 bar
0067732000



Portautensile rotante orientabile di foratura/fresatura

- ER 16 411010000-65 1:1 EC
00675000902
- ER 16 411010001-65 1:1 IC 80 bar
00675000902
- ER 11 411007001-65 1:2 EC
00675000914
- ER 11 411007000-65 1:2 IC 80 bar
00675000914

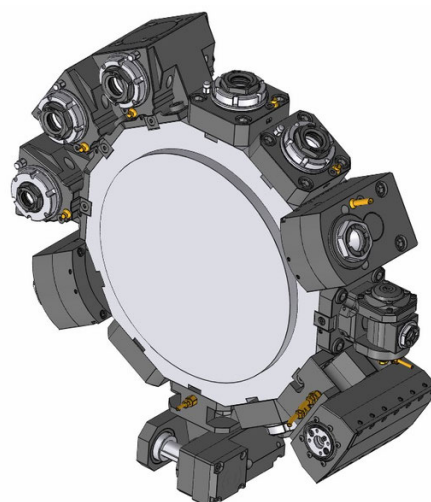
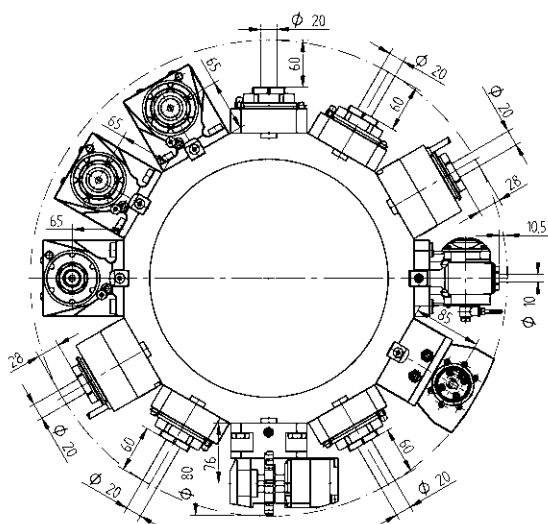

Portautensili Rotanti - Estensione del programma

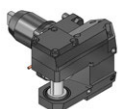

Portautensile rotante disassato per frese a disco

Tipo 14-2 411500001-65 2,73:1 EC

00675000448

 160016142 Ø 16

 160022142 Ø 22

 160027142 Ø 27

 160015142 Ø 5/8"

 160019142 Ø 3/4"

 160023142 Ø 7/8"

 160025142 Ø 1"



Unità di brocciatura per interni ed esterni

TN765050 414532003-65 1:1 EC

Bussole cilindriche standard di riduzione



Bussola di riduzione Ø 25

240025006	Ø 6
240025008	Ø 8
240025010	Ø 10
240025012	Ø 12
240025014	Ø 14
240025016	Ø 16
240025020	Ø 20



Bussola di riduzione Ø 32

240032006	Ø 6
240032008	Ø 8
240032010	Ø 10
240032012	Ø 12
240032014	Ø 14
240032016	Ø 16
240032018	Ø 18
240032020	Ø 20
240032025	Ø 25



Bussola di riduzione Ø 40

240040006	Ø 6
240040008	Ø 8
240040010	Ø 10
240040012	Ø 12
240040014	Ø 14
240040016	Ø 16
240040020	Ø 20
240040025	Ø 25
240040032	Ø 32

Bussole di riduzione standard cono Morse

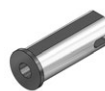

Bussola di riduzione Ø 40

240540001	MT 1
240540002	MT 2
240540003	MT 3
240540004	MT 4

Pinze DIN 6499B (ER/ESX)

Pinze DIN 6499B (ER/ESX)



ER 11

190011000	∅ 7-0.5	∅ 0.276-0.020
190011010	∅ 1-0.5	∅ 0.039-0.020
190011015	∅ 1.5-1	∅ 0.059-0.039
190011020	∅ 2-1.5	∅ 0.079-0.059
190011025	∅ 2.5-2	∅ 0.098-0.079
190011030	∅ 3-2.5	∅ 0.118-0.098
190011035	∅ 3.5-3	∅ 0.138-0.118
190011040	∅ 4-3.5	∅ 0.158-0.138
190011045	∅ 4.5-4	∅ 0.177-0.158
190011050	∅ 5-4.5	∅ 0.197-0.177
190011055	∅ 5.5-5	∅ 0.217-0.197
190011060	∅ 6-5.5	∅ 0.236-0.217
190011065	∅ 6.5-6	∅ 0.256-0.236
190011070	∅ 7-6.5	∅ 0.276-0.256



ER 25

190025000	∅ 16-1	∅ 0.630-0.039
190025010	∅ 1-0.5	∅ 0.039-0.020
190025020	∅ 2-1	∅ 0.079-0.039
190025030	∅ 3-2	∅ 0.118-0.079
190025040	∅ 4-3	∅ 0.157-0.118
190025050	∅ 5-4	∅ 0.197-0.157
190025060	∅ 6-5	∅ 0.236-0.197
190025070	∅ 7-6	∅ 0.276-0.236
190025080	∅ 8-7	∅ 0.315-0.276
190025090	∅ 9-8	∅ 0.354-0.315
190025100	∅ 10-9	∅ 0.394-0.354
190025110	∅ 11-10	∅ 0.433-0.394
190025120	∅ 12-11	∅ 0.472-0.433
190025130	∅ 13-12	∅ 0.512-0.472
190025140	∅ 14-13	∅ 0.551-0.512
190025150	∅ 15-14	∅ 0.591-0.551
190025160	∅ 16-15	∅ 0.630-0.591



ER 16

190016000	∅ 10-0.5	∅ 0.394-0.020
190016010	∅ 1-0.5	∅ 0.039-0.020
190016020	∅ 2-1	∅ 0.079-0.039
190016030	∅ 3-2	∅ 0.118-0.079
190016040	∅ 4-3	∅ 0.158-0.118
190016050	∅ 5-4	∅ 0.197-0.158
190016060	∅ 6-5	∅ 0.236-0.197
190016070	∅ 7-6	∅ 0.276-0.236
190016080	∅ 8-7	∅ 0.315-0.276
190016090	∅ 9-8	∅ 0.354-0.315
190016100	∅ 10-9	∅ 0.394-0.354



ER 32

190032000	∅ 20-2	∅ 0.787-0.079
190032020	∅ 2-1	∅ 0.079-0.039
190032030	∅ 3-2	∅ 0.118-0.079
190032040	∅ 4-3	∅ 0.157-0.118
190032050	∅ 5-4	∅ 0.197-0.157
190032060	∅ 6-5	∅ 0.236-0.197
190032070	∅ 7-6	∅ 0.276-0.236
190032080	∅ 8-7	∅ 0.315-0.276
190032090	∅ 9-8	∅ 0.354-0.315
190032100	∅ 10-9	∅ 0.394-0.354
190032110	∅ 11-10	∅ 0.433-0.394
190032120	∅ 12-11	∅ 0.472-0.433
190032130	∅ 13-12	∅ 0.512-0.472
190032140	∅ 14-13	∅ 0.551-0.512
190032150	∅ 15-14	∅ 0.591-0.551
190032160	∅ 16-15	∅ 0.630-0.591
190032170	∅ 17-16	∅ 0.669-0.630
190032180	∅ 18-17	∅ 0.709-0.669
190032190	∅ 19-18	∅ 0.748-0.709
190032200	∅ 20-19	∅ 0.787-0.748



ER 20

190020000	∅ 13-1	∅ 0.512-0.039
190020010	∅ 1-0.5	∅ 0.039-0.020
190020020	∅ 2-1	∅ 0.079-0.039
190020030	∅ 3-2	∅ 0.118-0.079
190020040	∅ 4-3	∅ 0.157-0.118
190020050	∅ 5-4	∅ 0.197-0.157
190020060	∅ 6-5	∅ 0.236-0.197
190020070	∅ 7-6	∅ 0.276-0.236
190020080	∅ 8-7	∅ 0.315-0.276
190020090	∅ 9-8	∅ 0.354-0.315
190020100	∅ 10-9	∅ 0.394-0.354
190020110	∅ 11-10	∅ 0.433-0.394
190020120	∅ 12-11	∅ 0.472-0.433
190020130	∅ 13-12	∅ 0.512-0.472

Pinze DIN 6499B (ER/ESX)



ER 40

190040000	ø 26-3	ø 1.024-0.118
190040030	ø 3-2	ø 0.118-0.079
190040040	ø 4-3	ø 0.157-0.118
190040050	ø 5-4	ø 0.197-0.157
190040060	ø 6-5	ø 0.236-0.197
190040070	ø 7-6	ø 0.276-0.236
190040080	ø 8-7	ø 0.315-0.276
190040090	ø 9-8	ø 0.354-0.315
190040100	ø 10-9	ø 0.394-0.354
190040110	ø 11-10	ø 0.433-0.394
190040120	ø 12-11	ø 0.472-0.433
190040130	ø 13-12	ø 0.512-0.472
190040140	ø 14-13	ø 0.551-0.512
190040150	ø 15-14	ø 0.591-0.551
190040160	ø 16-15	ø 0.630-0.591
190040170	ø 17-16	ø 0.669-0.630
190040180	ø 18-17	ø 0.709-0.669
190040190	ø 19-18	ø 0.748-0.709
190040200	ø 20-19	ø 0.787-0.748
190040210	ø 21-20	ø 0.827-0.787
190040220	ø 22-21	ø 0.866-0.827
190040230	ø 23-22	ø 0.906-0.866
190040240	ø 24-23	ø 0.945-0.906
190040250	ø 25-24	ø 0.984-0.945
190040260	ø 26-25	ø 1.024-0.984

Pinze DIN 6499B (ER/ESX) - vulcanizzate per refrigerante



ER 11

191011030	ø 3	
191011040	ø 4	
191011050	ø 5	
191011060	ø 6	
191111013-in		ø 0.125
191111019-in		ø 0.188
191111025-in		ø 0.25



ER 16

191016000	ø 3-10	
191016030	ø 3	
191016040	ø 4	
191016050	ø 5	
191016060	ø 6	
191016070	ø 7	
191016080	ø 8	
191016090	ø 9	
191016100	ø 10	
191116001		ø 0.125-0.375
191116013-in		ø 0.125
191116019-in		ø 0.188
191116025-in		ø 0.25
191116031-in		ø 0.313
191116038-in		ø 0.375



ER 20

191020000	ø 3-12	
191020030	ø 3	
191020040	ø 4	
191020050	ø 5	
191020060	ø 6	
191020070	ø 7	
191020080	ø 8	
191020090	ø 9	
191020100	ø 10	
191020110	ø 11	
191020120	ø 12	
191120001		ø 0.125-0.5
191120013-in		ø 0.125
191120019-in		ø 0.188
191120025-in		ø 0.25
191120031-in		ø 0.313
191120038-in		ø 0.375
191120044-in		ø 0.438
191120050-in		ø 0.5

Pinze DIN 6499B (ER/ESX) - vulcanizzate per refrigerante

Pinze DIN 6499B (ER/ESX) - vulcanizzate per refrigerante



ER 25

191025000	ø 4-16	
191025030	ø 3	
191025040	ø 4	
191025050	ø 5	
191025060	ø 6	
191025070	ø 7	
191025080	ø 8	
191025090	ø 9	
191025100	ø 10	
191025110	ø 11	
191025120	ø 12	
191025130	ø 13	
191025140	ø 14	
191025150	ø 15	
191025160	ø 16	
191125001		ø 0.25-0.625
191125025-in		ø 0.25
191125031-in		ø 0.313
191125038-in		ø 0.375
191125044-in		ø 0.438
191125050-in		ø 0.5
191125056-in		ø 0.563
191125063-in		ø 0.625



ER 40

191040060	ø 6	
191040080	ø 8	
191040100	ø 10	
191040120	ø 12	
191040140	ø 14	
191040160	ø 16	
191040180	ø 18	
191040200	ø 20	
191040220	ø 22	
191040250	ø 25	
191140025-in		ø 0.25
191140031-in		ø 0.313
191140038-in		ø 0.375
191140044-in		ø 0.438
191140050-in		ø 0.5
191140056-in		ø 0.563
191140063-in		ø 0.625
191140069-in		ø 0.688
191140075-in		ø 0.75
191140088-in		ø 0.875
191140100-in		ø 1



ER 32

191032000	ø 4-20	
191032030	ø 3	
191032040	ø 4	
191032050	ø 5	
191032060	ø 6	
191032070	ø 7	
191032080	ø 8	
191032090	ø 9	
191032100	ø 10	
191032110	ø 11	
191032120	ø 12	
191032130	ø 13	
191032140	ø 14	
191032150	ø 15	
191032160	ø 16	
191032170	ø 17	
191032180	ø 18	
191032190	ø 19	
191032200	ø 20	
191132001		ø 0.25-0.75
191132025-in		ø 0.25
191132031-in		ø 0.313
191132038-in		ø 0.375
191132044-in		ø 0.438
191132050-in		ø 0.5
191132056-in		ø 0.563
191132063-in		ø 0.625
191132069-in		ø 0.688
191132075-in		ø 0.75



Qualità senza compromessi.

Tutte le fasi di lavorazione sono eseguite alla perfezione.

Dalla fase di progettazione fino alla fine della produzione non facciamo compromessi in termini di qualità.

I nostri prodotti sono costantemente controllati con macchine di misura 3D durante tutte le fasi del ciclo di produzione.

WTO nel mondo

WTO

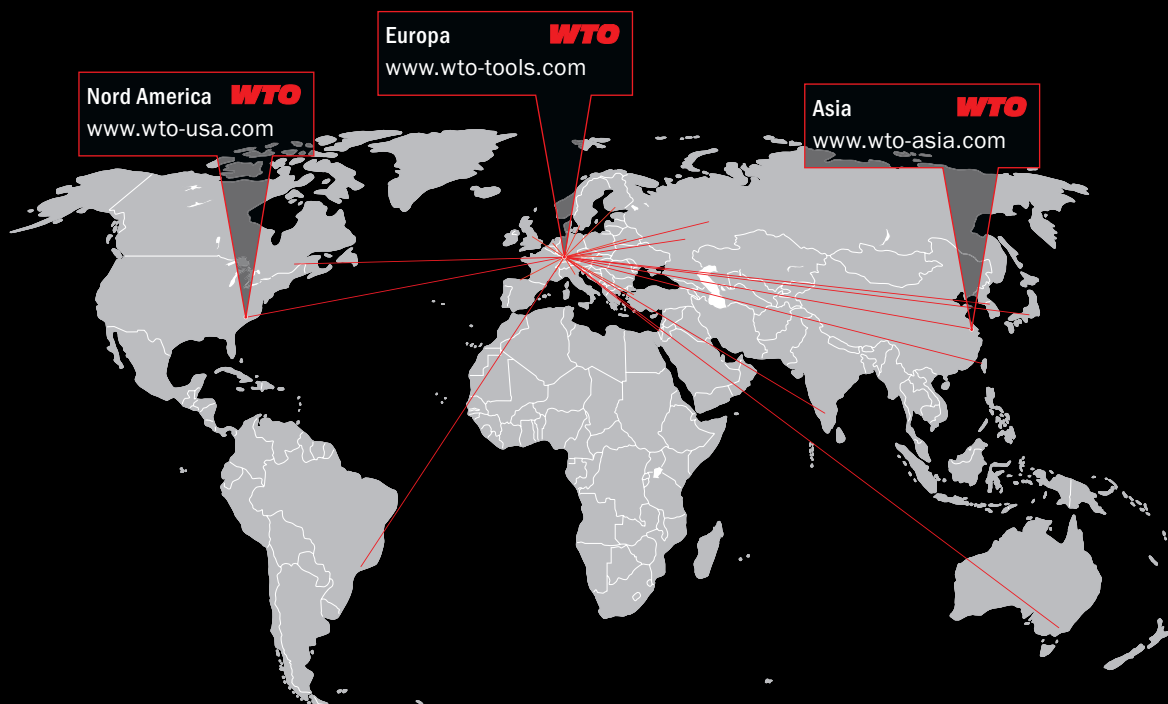

WTO
Werkzeug-
Einrichtungen GmbH
Neuer Hohdammweg 1
77797 Ohlsbach
Germania

WTO Inc.
13900-F South Lakes Dr.
Charlotte, NC 28273
Stati Uniti d'America

WTO Asia
WTO Precision Tool Holders
(Shanghai) Co. Ltd.
Room 109-110, Building 2
No. 228 Banting Road
Jiuting Town,
Songjiang District
201615 Shanghai
Cina

Our distribution partners. Competence right there.

Australia
Dimac Tooling Ltd.
sales@dimac.com.au

Finland
Suomen Terästuonti Oy
myynti@stt.as

Korea
WTO Office Korea
is.chon@wto-korea.com

Spain
ITALMATIC, S.A.
italmatic@italmatic.es

Belarus
LLC „PMI Engineering“
tool@pmi.by

France
Alexandre Mathelin
alm@wto.de

Messico
Workholding Engineering De México
info@wem.com.mx

Sweden
Bonthron & Ewing AB
info@bonthron-ewing.se

Brazil
TF2
tfdois@tfdois.com.br

Great Britain
Cutwel Ltd.
sales@cutwel.net

Netherlands
Toologic BeNeLux B.V.
info@toologic-benelux.nl

Switzerland
Utilis AG
info@utilis.com

Canada
Mittmann Industrial Inc.
info@mittmann.com

India
Ulhas Patil
u.patil@wto-asia.com

Norway
Helge Karlsen Verktøy og Maskin AS
hkvm@hkvm.no

Taiwan
Kaiko Co., Ltd.
info@kaiko.com.tw

China
Shanghai Gangde
wtocando@yahoo.com

Israel
E.Y.A.R. Ltd.
boris@eyar.co.il

Polonia
ARCO Andrzej Rudenko
info@arcotools.pl

Turkey
MYK CNC MAKINA SAN. VE
huseyin.tatlidil@mykcnc.com.tr

Czech Republic
ALBA precision, spol. s.r.o.
info@albaprecision.cz

Italy
Prymark srl
commerciale@prymark.it

Romania
SC Elif Trading SRL
bulent.ozkan@eliftrading.com

Ukraine
„LLC“ SPA Stankopromimport
info@phoenix-ua.com

Denmark
AVN Teknik A/S
cjo@avn.dk

Japan
NK Works Co. Ltd.
k_samba@nk-works.co.jp

Slovakia
ALBA precision s.r.o.
albaprecision@albaprecision.sk