

## Programma Portautensili

NS 2100 SY

PL 1600, 2000M

SL 1500, 2000M/Y/SY

SL 2000 T2Y2

SL 2500, 3000M/Y/SY, PL 2000, 2500Y/SY

SL 3500M/Y, PL 20-35M, 2000-2500MS

SL 4500, 5500M, SL 4500LY, PL 45M/LY

SL 6500, 8500M, PL 60-80M

PL 250V/VM

SLV 500M

SLV 800M, PL 800VM

SLV 1000M

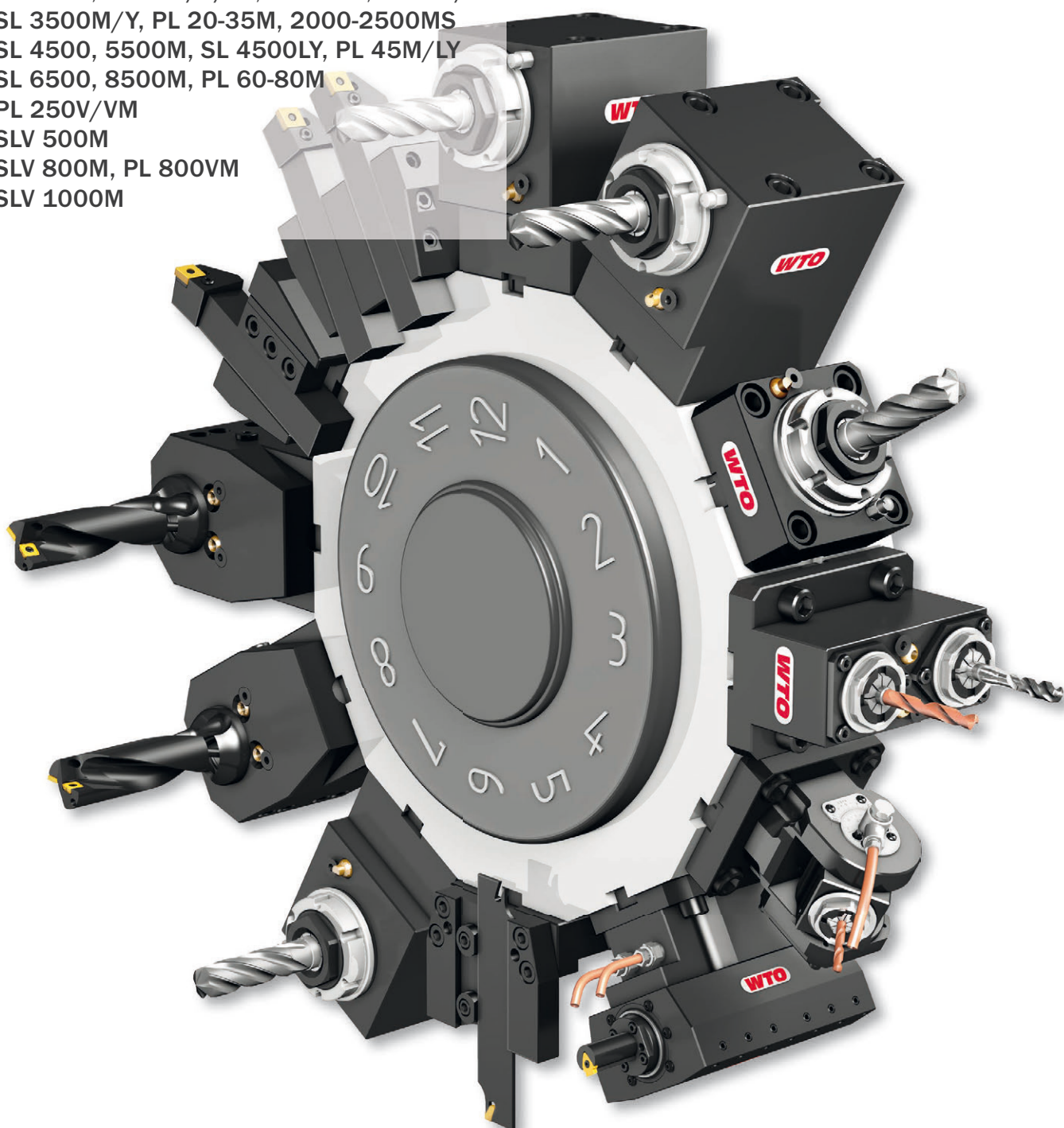

# QuickFlex<sup>®</sup>

Nuovo sistema a cambio rapido per elevate prestazioni e precisione.

Minimo investimento, massima versatilità.

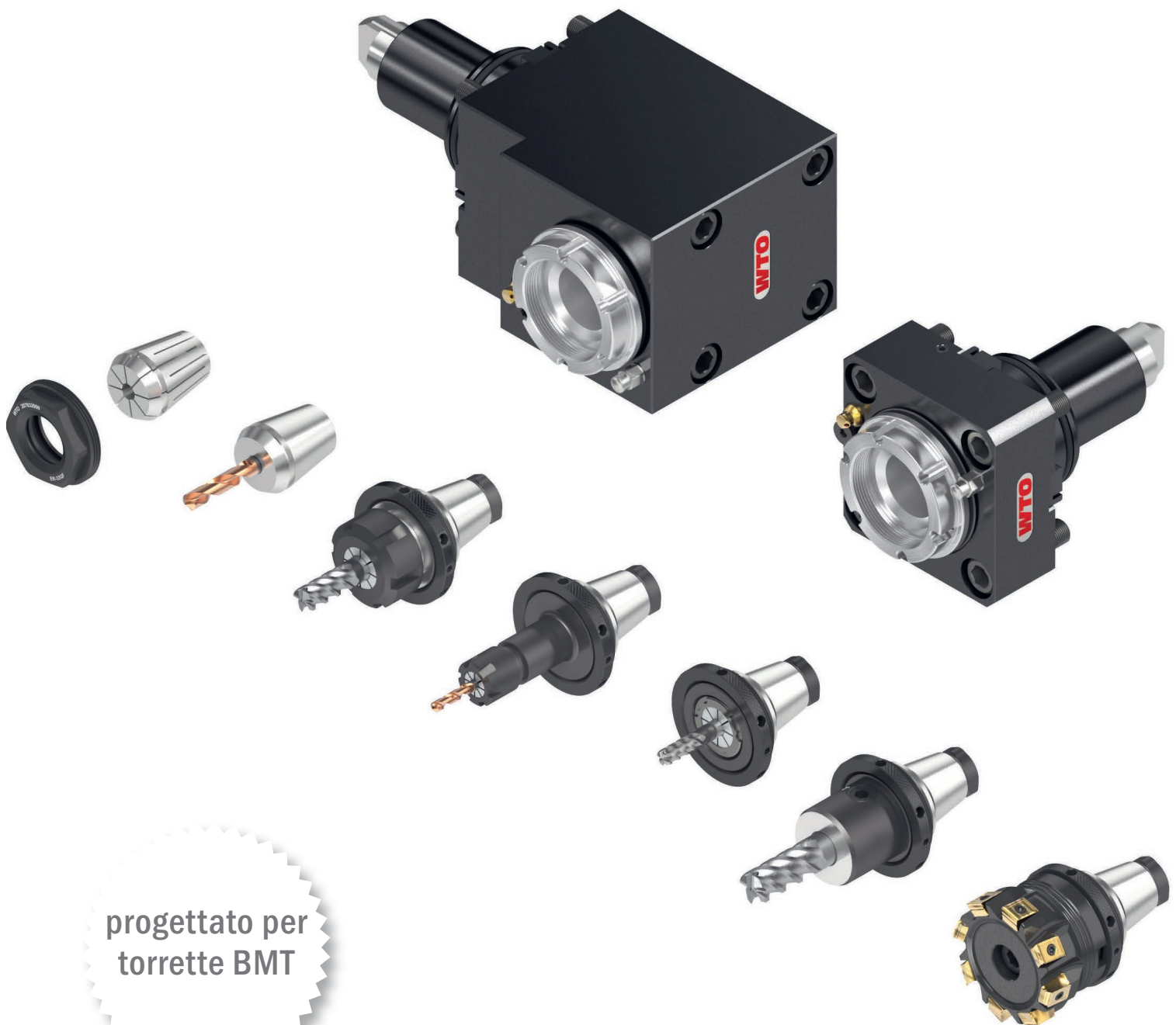

progettato per  
torrette BMT

NS 2100 SY	Pagina 4 - 6
PL 1600, 2000M	Pagina 7 - 9
SL 1500, 2000M/Y/SY	Pagina 10 - 13
SL 2000 T2Y2	Pagina 14 - 16
SL 2500, 3000M/Y/SY, PL 2000, 2500Y/SY	Pagina 17 - 20
SL 3500M/Y, PL 20-35M, 2000-2500MS	Pagina 21 - 24
SL 4500, 5500M, SL 4500LY, PL 45M/LY	Pagina 25 - 26
SL 6500, 8500M, PL 60-80M	Pagina 27 - 28
PL 250V/VM	Pagina 29 - 31
SLV 500M	Pagina 32 - 34
SLV 800M, PL 800VM	Pagina 35 - 36
SLV 1000M	Pagina 37 - 38
Pinze	Pagina 41 - 43

**EC = adduzione esterna refrigerante**  
**HP-IC = adduzione interna refrigerante alta pressione attraverso l'utensile**  
**IC 80 bar = adduzione esterna ed interna refrigerante**  
Massima pressione refrigerante = 80 bar  
**IC 30 bar = adduzione esterna ed interna refrigerante**  
Massima pressione refrigerante = 30 bar  
usare solo refrigerante filtrato (dim. Max. =50 µm)  
non utilizzare senza refrigerante!  
non utilizzare per lavorazione di ghise

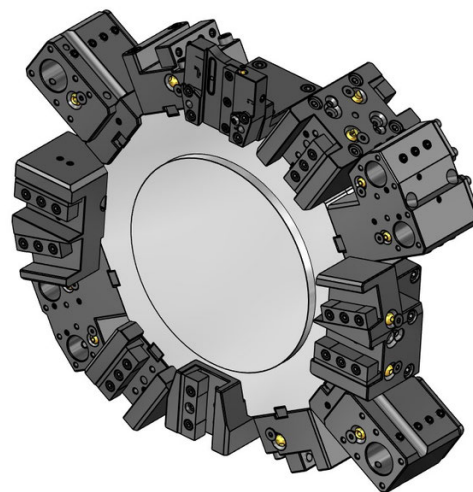
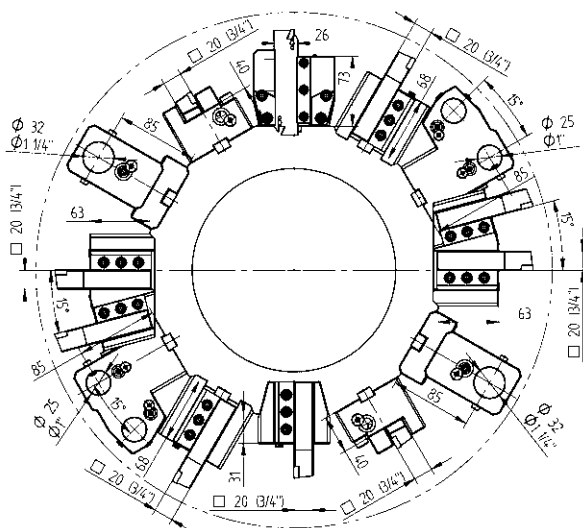

Portautensili statici - Programma standard



**Portautensile**  
20 48-116996



**Portautensile per lavorazione su mandrino e contromandrino**  
20 48-116997



**Portautensile per esterni**  
20 48-109148



**Portautensile combinato**  
Ø 32 48-116998 IC 80 bar

Portautensili statici - Estensione del programma



**Portautensile doppio, 24 stazioni**  
20 48-116923

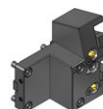

**Portautensile doppio, 24 stazioni, per contromandrino**  
20 48-116924



**Portautensile da taglio, con regolazione**  
SH 26 48-94968



**Portautensile da taglio, con regolazione, HP-IC**  
SH 26 48-102252R IC 80 bar  
SH 26 48-102252L IC 80 bar



**Portautensile combinato, universale, doppio, 24 stazioni**  
Ø 25 48-116925 IC 80 bar

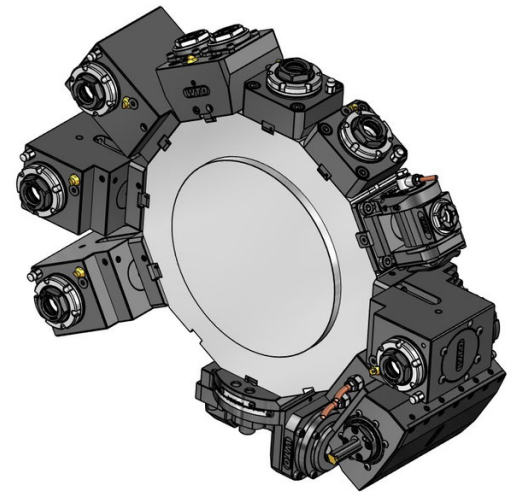
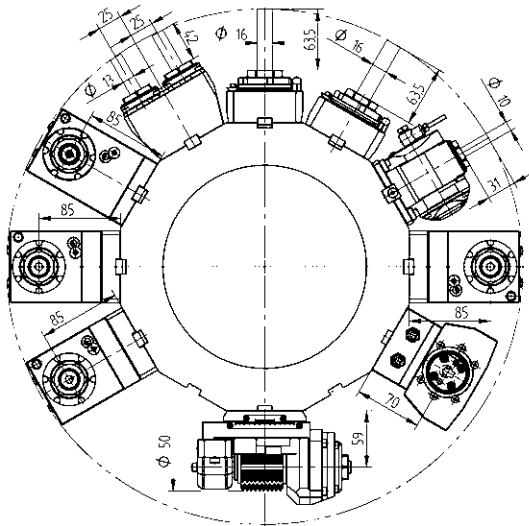

Portautensili Rotanti - QuickFlex®



**Portautensile rotante di foratura/fresatura**

- |                 |              |     |           |
|-----------------|--------------|-----|-----------|
| <b>ER-25 QF</b> | 420125015-45 | 1:1 | EC        |
|                 | 0067725000   |     |           |
| <b>ER-25 QF</b> | 420125016-45 | 1:1 | IC 80 bar |
|                 | 0067725000   |     |           |



**Portautensile rotante di foratura/fresatura, LF=85**

- |                 |              |     |           |
|-----------------|--------------|-----|-----------|
| <b>ER-25 QF</b> | 420525056-45 | 1:1 | EC        |
|                 | 0067725000   |     |           |
| <b>ER-25 QF</b> | 420525057-45 | 1:1 | IC 80 bar |
|                 | 0067725000   |     |           |



**Portautensile rotante radiale, per lavorazione su mandrino e contromandrino, LF=85**

- |                 |              |     |    |
|-----------------|--------------|-----|----|
| <b>ER-25 QF</b> | 420525043-45 | 1:1 | EC |
|                 | 0067725000   |     |    |

Portautensili Rotanti - Estensione del programma



**Portautensile rotante di foratura/fresatura, disassato**

- |              |              |     |           |
|--------------|--------------|-----|-----------|
| <b>ER 16</b> | 410410008-45 | 1:3 | EC        |
|              | 00675000937  |     |           |
| <b>ER 16</b> | 410410002-45 | 1:3 | IC 80 bar |
|              | 00675000937  |     |           |



**Portautensile rotante orientabile di foratura/fresatura**

- |              |              |     |           |
|--------------|--------------|-----|-----------|
| <b>ER 16</b> | 411010008-45 | 1:1 | EC        |
|              | 00675000902  |     |           |
| <b>ER 16</b> | 411010009-45 | 1:1 | IC 80 bar |
|              | 00675000902  |     |           |
| <b>ER 11</b> | 411007004-45 | 1:2 | EC        |
|              | 00675000914  |     |           |
| <b>ER 11</b> | 411007005-45 | 1:2 | IC 80 bar |
|              | 00675000914  |     |           |



**Unità porta creatore**

- |                  |                  |     |    |
|------------------|------------------|-----|----|
| <b>Tipo 15-2</b> | 410900003-45     | 1:1 | EC |
|                  | 00675001015      |     |    |
|                  | 160008152 Ø 8    |     |    |
|                  | 160010152 Ø 10   |     |    |
|                  | 160013152 Ø 13   |     |    |
|                  | 160016152 Ø 16   |     |    |
|                  | 160022152 Ø 22   |     |    |
|                  | 160015152 Ø 5/8" |     |    |
|                  | 160019152 Ø 3/4" |     |    |
|                  | 110587           |     |    |

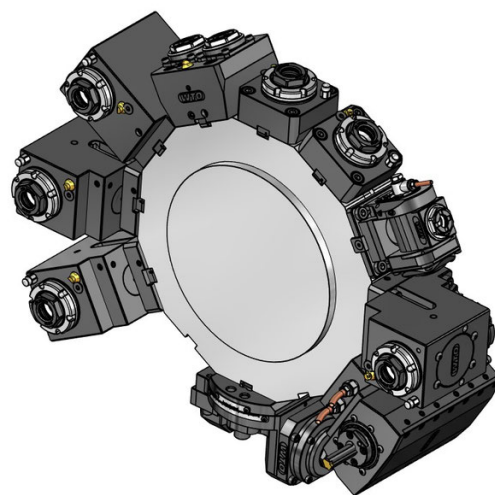
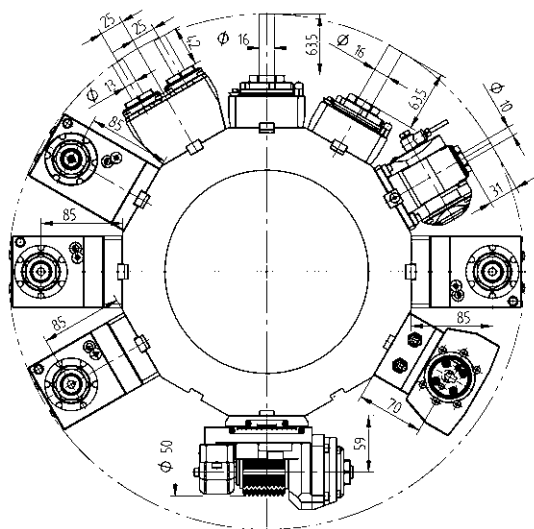

### Portautensili Rotanti - Estensione del programma



#### Portautensile rotante di foratura/fresatura - doppio, asse Y

ER 20	413002006-45	1:1	EC
	 00675000947		
ER 20	413002008-45	1:1	IC 80 bar
	 00675000947		



#### Unità di brocciatura per interni ed esterni

Tipo 32	414532005-45	1:1	EC
---------	--------------	-----	----

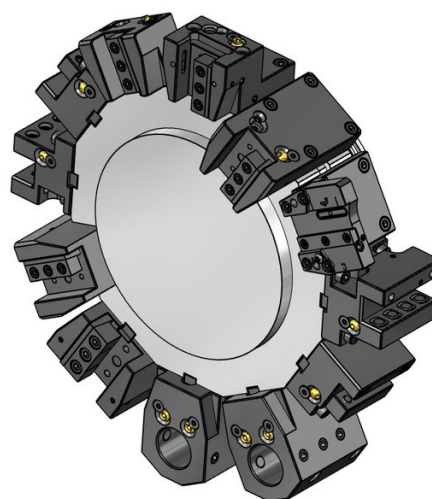
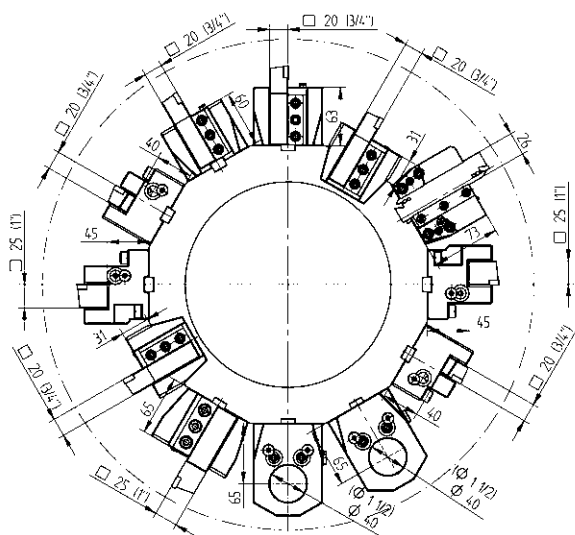

Portautensili statici - Programma standard

Portautensili statici - Programma standard



**Portautensile**

20 48-95083



**Portautensile da taglio, con regolazione**

SH 26 48-94968



**Portautensile, HP-IC**

20 48-100605-HP IC 80 bar



**Portautensile da taglio, con regolazione, HP-IC**

SH 26 48-102252R IC 80 bar  
SH 26 48-102252L IC 80 bar



**Portautensile, HP-IC**

25 48-104395-HP IC 80 bar



**Portautensile combinato, LF=65**

Ø 40 48-95090 IC 80 bar



**Portautensile corto**

20 48-108330



**Portautensile per esterni**

20 48-109148



**Portautensile per esterni, HP-IC**

20 48-109148-HP IC 80 bar



**Portautensile per esterni, HP-IC**

25 48-104397-HP IC 80 bar

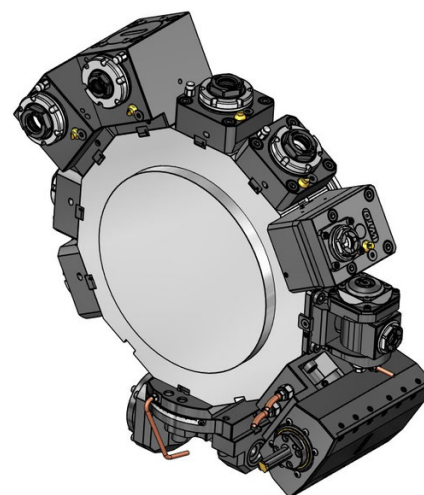
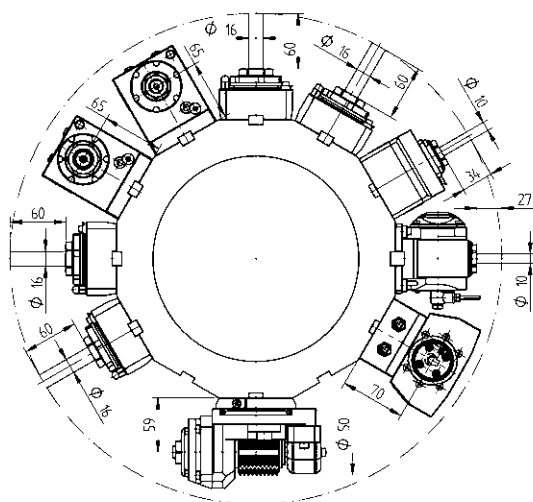

Portautensili Rotanti - QuickFlex®



**Portautensile rotante di foratura/fresatura**

- |                 |              |     |           |
|-----------------|--------------|-----|-----------|
| <b>ER-25 QF</b> | 420125015-45 | 1:1 | EC        |
|                 | 0067725000   |     |           |
| <b>ER-25 QF</b> | 420125016-45 | 1:1 | IC 80 bar |
|                 | 0067725000   |     |           |



**Portautensile rotante di foratura/fresatura, LF=65**

- |                 |              |     |           |
|-----------------|--------------|-----|-----------|
| <b>ER-25 QF</b> | 420525015-45 | 1:1 | EC        |
|                 | 0067725000   |     |           |
| <b>ER-25 QF</b> | 420525016-45 | 1:1 | IC 80 bar |
|                 | 0067725000   |     |           |

Portautensili Rotanti - Estensione del programma



**Portautensile rotante di foratura/fresatura, disassato**

- |              |              |     |           |
|--------------|--------------|-----|-----------|
| <b>ER 16</b> | 410410008-45 | 1:3 | EC        |
|              | 00675000937  |     |           |
| <b>ER 16</b> | 410410002-45 | 1:3 | IC 80 bar |
|              | 00675000937  |     |           |



**Portautensile rotante di foratura/fresatura, LF=65**

- |                 |              |     |           |
|-----------------|--------------|-----|-----------|
| <b>ER-20 QF</b> | 420520018-45 | 1:2 | EC        |
|                 | 0067720001   |     |           |
| <b>ER-20 QF</b> | 420520019-45 | 1:2 | IC 80 bar |
|                 | 0067720001   |     |           |
| <b>ER-25 QF</b> | 420525020-45 | 2:1 | EC        |
|                 | 0067725000   |     |           |
| <b>ER-25 QF</b> | 420525021-45 | 2:1 | IC 80 bar |
|                 | 0067725000   |     |           |



**Portautensile rotante orientabile di foratura/fresatura**

- |              |              |     |           |
|--------------|--------------|-----|-----------|
| <b>ER 16</b> | 411010008-45 | 1:1 | EC        |
|              | 00675000902  |     |           |
| <b>ER 16</b> | 411010009-45 | 1:1 | IC 80 bar |
|              | 00675000902  |     |           |
| <b>ER 11</b> | 411007004-45 | 1:2 | EC        |
|              | 00675000914  |     |           |
| <b>ER 11</b> | 411007005-45 | 1:2 | IC 80 bar |
|              | 00675000914  |     |           |



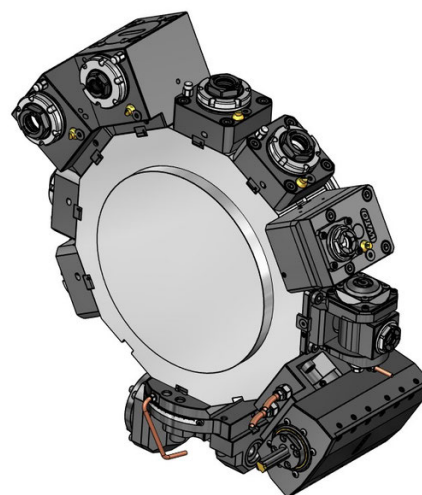
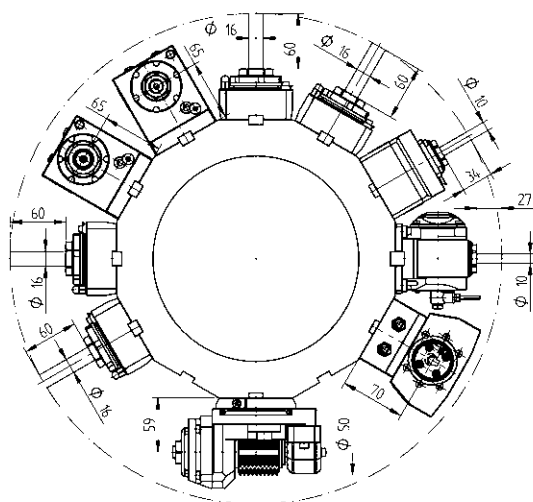

Portautensili Rotanti - Estensione del programma



**Unità porta creatore**

Tipo 15-2 410900003-45 1:1 EC

-  00675001015
-  160008152 Ø 8
-  160010152 Ø 10
-  160013152 Ø 13
-  160016152 Ø 16
-  160022152 Ø 22
-  160015152 Ø 5/8"
-  160019152 Ø 3/4"
-  110587



**Unità di brocciatura per interni ed esterni**

Tipo 32 414532005-45 1:1 EC

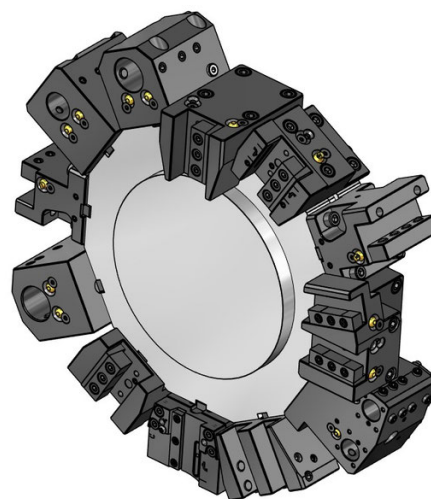
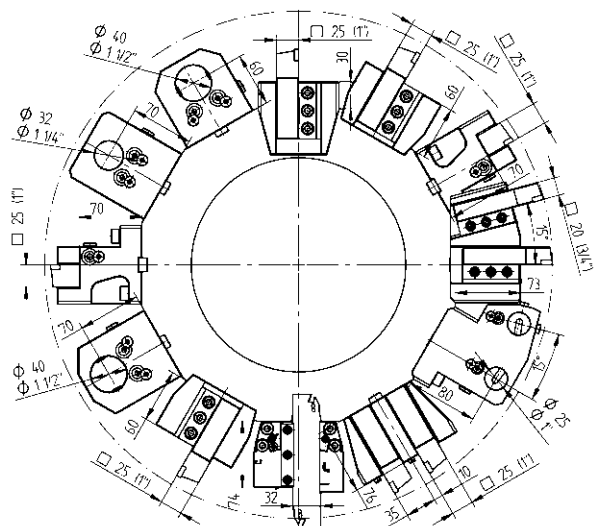

Portautensili statici - Programma standard

Portautensili statici - Estensione del programma



**25** Portautensile

48-87097



**25** Portautensile, HP-IC

48-87097-HP IC 80 bar



**25** Portautensile corto

48-108331



**25** Portautensile per lavorazione su mandrino e contromandrino

48-117285

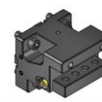

**25** Portautensile per esterni

48-87101

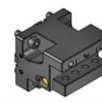

**25** Portautensile per esterni, HP-IC

48-87101-HP IC 80 bar



**Ø 40** Portautensile combinato, LF=60

48-112454 IC 80 bar



**20** Portautensile doppio, 24 stazioni

48-108747



**20** Portautensile doppio, 24 stazioni, per contromandrino

48-111193



**25(1")** Portautensile doppio, asse Y

48-87140



**25(1")** Portautensile per lavorazione su mandrino e contromandrino, doppio, asse Y

48-87141



**SH 32** Portautensile da taglio, con regolazione

48-103287



**SH 32** Portautensile da taglio, con regolazione, HP-IC

48-110160R IC 80 bar

48-110160L IC 80 bar



**Ø 32** Portautensile combinato, LF=70

48-106897 IC 80 bar

Ø 40 48-87103 IC 80 bar

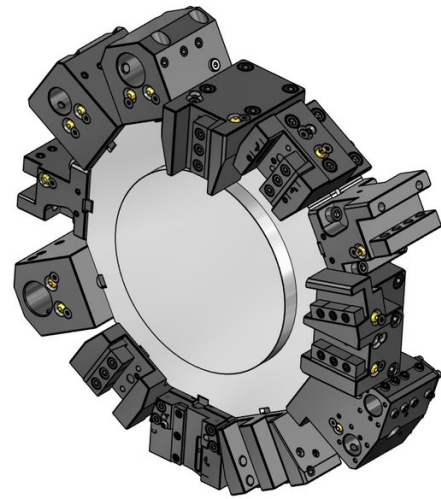
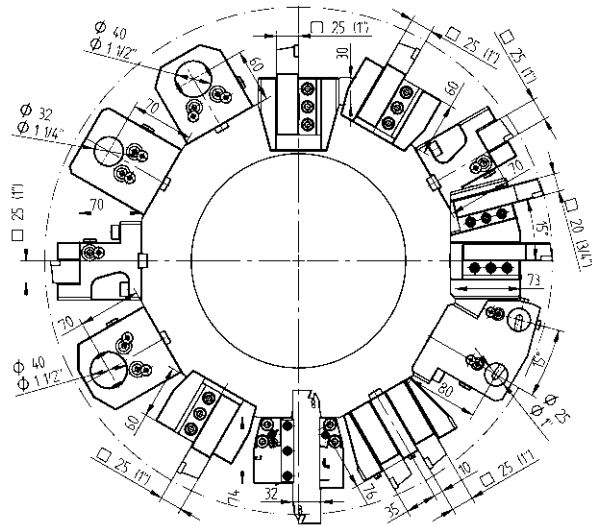

Portautensili statici - Estensione del programma



Ø 25

**Portautensile combinato, universale, doppio,  
24 stazioni**

48-108748

IC 80 bar

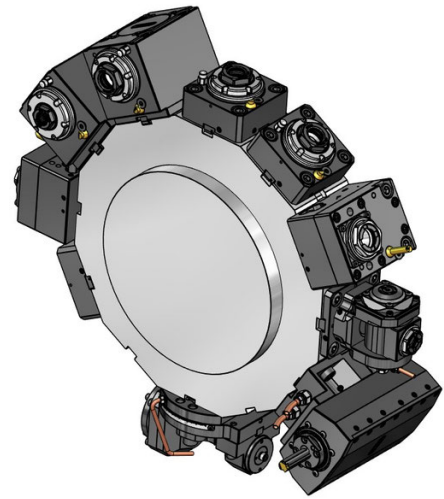
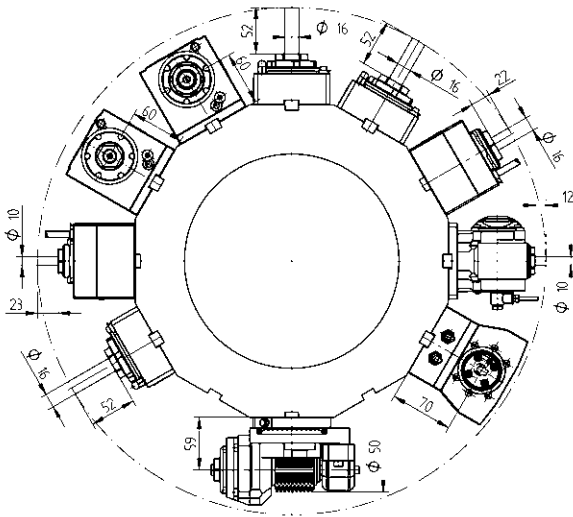

Portautensili Rotanti - QuickFlex®



**Portautensile rotante di foratura/fresatura**

- |                 |              |     |           |
|-----------------|--------------|-----|-----------|
| <b>ER-25 QF</b> | 420125015-55 | 1:1 | EC        |
|                 | 0067725000   |     |           |
| <b>ER-25 QF</b> | 420125016-55 | 1:1 | IC 80 bar |
|                 | 0067725000   |     |           |



**Portautensile rotante di foratura/fresatura, LF=60**

- |                 |              |     |           |
|-----------------|--------------|-----|-----------|
| <b>ER-25 QF</b> | 420525021-55 | 1:1 | EC        |
|                 | 0067725000   |     |           |
| <b>ER-25 QF</b> | 420525022-55 | 1:1 | IC 80 bar |
|                 | 0067725000   |     |           |



**Portautensile rotante radiale, per lavorazione su mandrino e contromandrino, LF=60**

- |                 |              |     |    |
|-----------------|--------------|-----|----|
| <b>ER-25 QF</b> | 420525023-55 | 1:1 | EC |
|                 | 0067725000   |     |    |

Portautensili Rotanti - Estensione del programma



**Portautensile rotante di foratura/fresatura**

- |              |              |     |           |
|--------------|--------------|-----|-----------|
| <b>ER 32</b> | 410120010-55 | 1:1 | EC        |
|              | 0067725000   |     |           |
| <b>ER 32</b> | 410120011-55 | 1:1 | IC 80 bar |
|              | 0067725000   |     |           |



**Portautensile rotante di fresatura con attacco combinato DIN 6358**

- |             |              |     |    |
|-------------|--------------|-----|----|
| <b>Ø 22</b> | 410222004-55 | 1:1 | EC |
|             | 00675000483  |     |    |



**Portautensile rotante di foratura/fresatura, disassato**

- |              |              |     |           |
|--------------|--------------|-----|-----------|
| <b>ER 25</b> | 410116029-55 | 1:1 | EC        |
|              | 00675000932  |     |           |
| <b>ER 25</b> | 410116030-55 | 1:1 | IC 80 bar |
|              | 00675000932  |     |           |
| <b>ER 20</b> | 410113009-55 | 1:2 | EC        |
|              | 00675000939  |     |           |
| <b>ER 20</b> | 410113010-55 | 1:2 | IC 80 bar |
|              | 00675000939  |     |           |
| <b>ER 16</b> | 410410004-55 | 1:3 | EC        |
|              | 00675000937  |     |           |
| <b>ER 16</b> | 410410005-55 | 1:3 | IC 80 bar |
|              | 00675000937  |     |           |

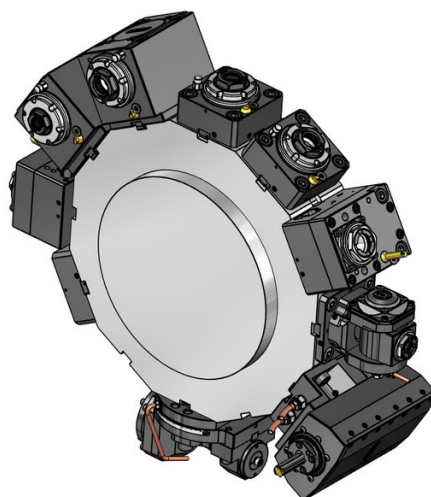
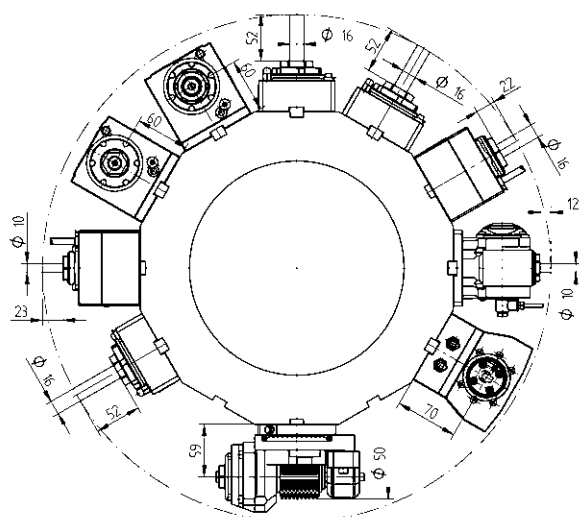

Portautensili Rotanti - Estensione del programma



**Portautensile rotante di foratura/fresatura, LF=60**

<b>ER 32</b>	410520049-55 0067725000	1:1	EC
<b>ER 32</b>	410520050-55 0067725000	1:1	IC 80 bar
<b>ER-20 QF</b>	420520016-55 0067720001	1:2	EC
<b>ER-20 QF</b>	420520017-55 0067720001	1:2	IC 80 bar
<b>ER 16</b>	410810026-55 00675000841	1:3	EC
<b>ER 16</b>	410810027-55 00675000841	1:3	IC 80 bar
<b>ER-25 QF</b>	420525034-55 0067725000	2:1	EC
<b>ER-25 QF</b>	420525035-55 0067725000	2:1	IC 80 bar



**Portautensile rotante radiale di fresatura con portafrese combinato DIN6358, LF=60**

<b>Ø 22</b>	410622012-55 00675000483	1:1	EC
-------------	-----------------------------	-----	----

Portautensili Rotanti - Estensione del programma



**Portautensile rotante orientabile di foratura/fresatura**

<b>ER 16</b>	411010005-55 00675000902	1:1	EC
<b>ER 16</b>	411010006-55 00675000902	1:1	IC 80 bar
<b>ER 11</b>	411007007-55 00675000914	1:2	EC
<b>ER 11</b>	411007008-55 00675000914	1:2	IC 80 bar



**Unità porta creatore**

<b>Tipo 15-2</b>	410900002-55 00675001015	1:1	EC
	160008152 Ø 8		
	160010152 Ø 10		
	160013152 Ø 13		
	160016152 Ø 16		
	160022152 Ø 22		
	160015152 Ø 5/8"		
	160019152 Ø 3/4"		
	110587		

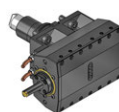

**Unità di brocciatura per interni ed esterni**

<b>Tipo 32</b>	414532001-55	1:1	EC
<b>Tipo 52</b>	414552000-55	1:1	EC

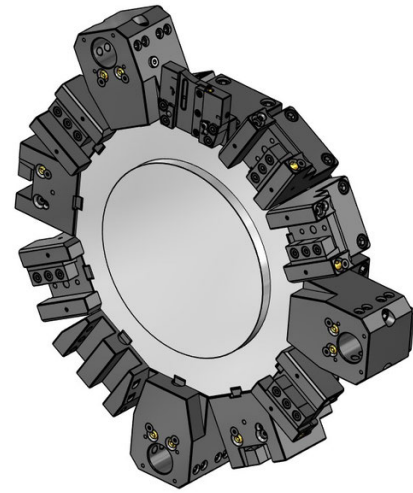
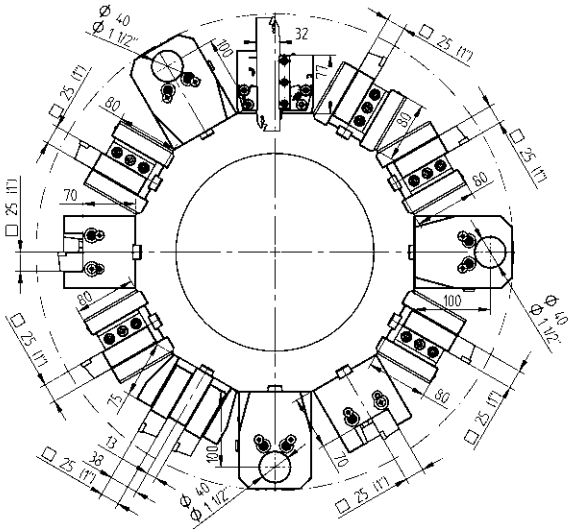

Portautensili statici - Programma standard

Portautensili statici - Estensione del programma



**25** Portautensile  
48-109110



**25** Portautensile per lavorazione su mandrino e contromandrino  
48-109198



**25** Portautensile per esterni  
48-86719



**25** Portautensile per esterni, HP-IC  
48-109249-HP IC 80 bar



**Ø 40** Portautensile combinato, LF=100  
48-112634 IC 80 bar  
241140026 ER40  
241140020 ER32



**48-87089** Coperchio di protezione



**20** Portautensile per lavorazione su mandrino e contromandrino, doppio, 24 stazioni  
48-109768



**25(1")** Portautensile doppio, asse Y  
48-86103



**25(1")** Portautensile per lavorazione su mandrino e contromandrino, doppio, asse Y  
48-86150



**SH 32** Portautensile da taglio, con regolazione  
48-99060



**SH 32** Portautensile da taglio, con regolazione, HP-IC  
48-102256R IC 80 bar  
48-102256L IC 80 bar

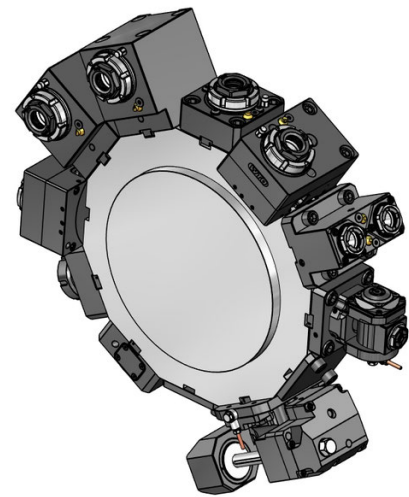
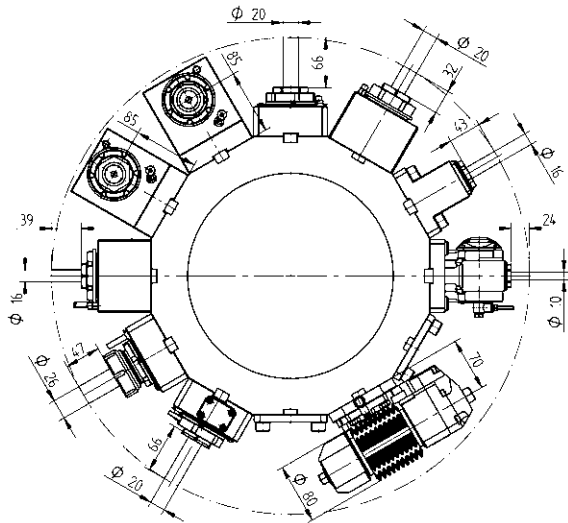

Portautensili Rotanti - QuickFlex®



**Portautensile rotante di foratura/fresatura**

- ER-32 QF** QF32-DNE-BT65A-058-E-A 1:1 EC  
0067732000
- ER-32 QF** QF32-DNE-BT65A-060-I-A 1:1 IC 100 bar  
0067732000



**Portautensile rotante di foratura/fresatura - QF smart (UE, US, CA, JP)**

- ER-32 QF** QF32-DNE-BT65A-060-I-SB-A 1:1 IC 100 bar  
0067732000
- LI-F12-01



**Portautensile rotante di foratura/fresatura, LF=85**

- ER-32 QF** 420532088-65 1:1 EC  
0067732000
- ER-32 QF** 420532089-65 1:1 IC 80 bar  
0067732000

Portautensili Rotanti - Estensione del programma



**Portautensile rotante di foratura/fresatura**

- ER 40** ER40-DNE-BT65A-084-E-A 1:1 EC  
00675000079
- ER 40** ER40-DNE-BT65A-086-I-A 1:1 IC 100 bar  
00675000079



**Portautensile rotante di foratura/fresatura, disassato**

- ER-32 QF** 420132037-65 1:1 EC  
0067732000
- ER-32 QF** 420132038-65 1:1 IC 80 bar  
0067732000
- ER-25 QF** 420125010-65 1:2 EC  
0067725001
- ER-25 QF** 420125011-65 1:2 IC 80 bar  
0067725001



**Portautensile rotante orientabile di foratura/fresatura**

- ER 16** 411010002-65 1:1 EC  
00675000902
- ER 16** 411010003-65 1:1 IC 80 bar  
00675000902
- ER 11** 411007002-65 1:2 EC  
00675000914
- ER 11** 411007003-65 1:2 IC 80 bar  
00675000914

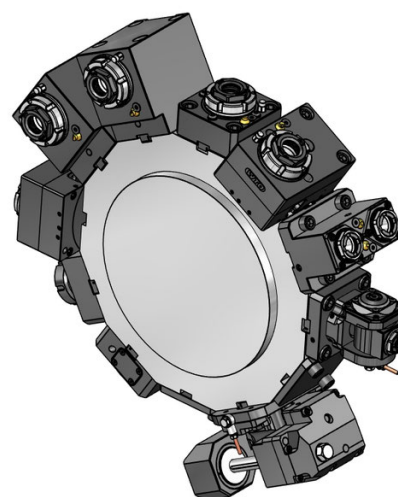
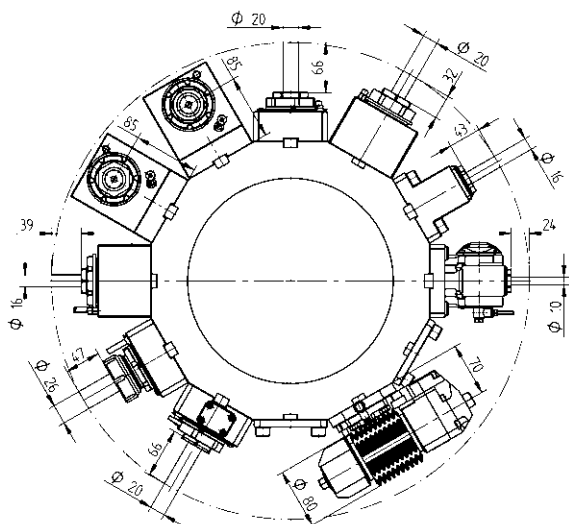

Portautensili Rotanti - Estensione del programma



**Unità porta creatore**

<b>Tipo 16-1</b>	411500003-65	1:1	EC
<b>Tipo 16-1</b>	411500002-65	2:1	EC

- 00675000927
- 160016161 Ø 16
- 160022161 Ø 22
- 160027161 Ø 27
- 160015161 Ø 5/8"
- 160019161 Ø 3/4"
- 160025161 Ø 1"
- 160031161 Ø 1 1/4"
- 110587



**Portautensile rotante di foratura e fresatura,  
per lavorazione su mandrino e contromandrino**

<b>ER 25</b>	413002005-65	1:1	EC
--------------	--------------	-----	----

- 00675000907



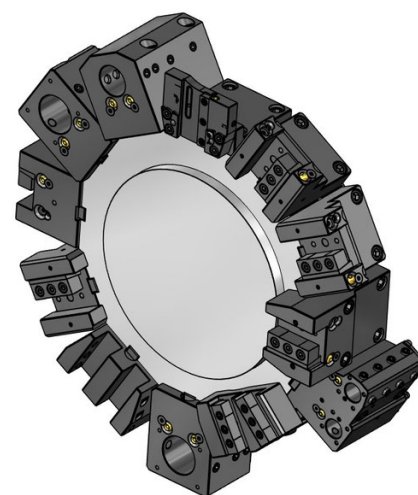
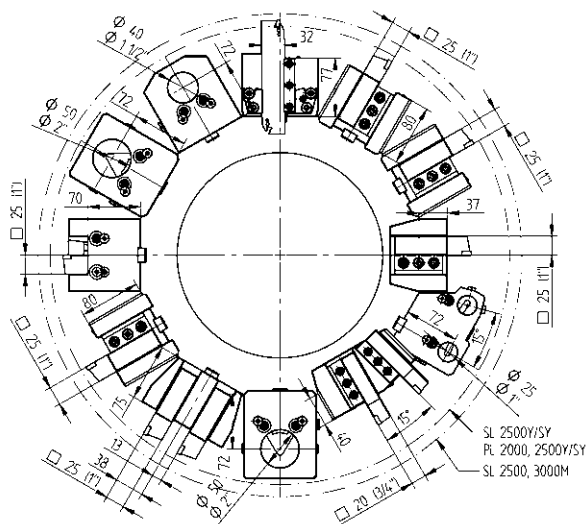

Portautensili statici - Programma standard

Portautensili statici - Programma standard



**Portautensile**

25 48-109110



**Portautensile corto**

25 48-86991



**Portautensile corto, HP-IC**

25 48-86991-HP IC 80 bar



**Portautensile per lavorazione su mandrino e contromandrino**

25 48-109198



**Portautensile per esterni**

25 48-86719



**Portautensile per esterni, HP-IC**

25 48-109249-HP IC 80 bar



**Portautensile per punte, universale, LF=72**

Ø 50 48-109214 IC 80 bar



**Portautensile combinato, LF=72**

Ø 40 48-84375 IC 80 bar  
Ø 50 48-107499 IC 80 bar



**Portabareno per lavorazione su mandrino e contromandrino**

Ø 40 48-117609



**Coperchio di protezione**

48-87089

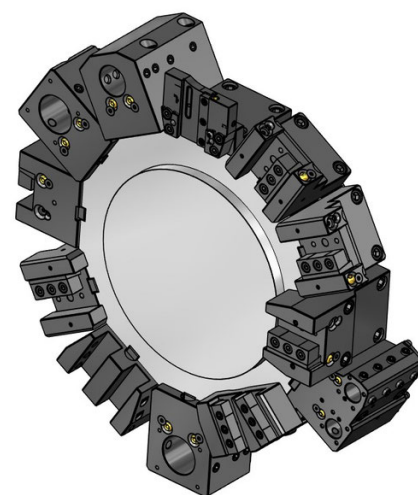
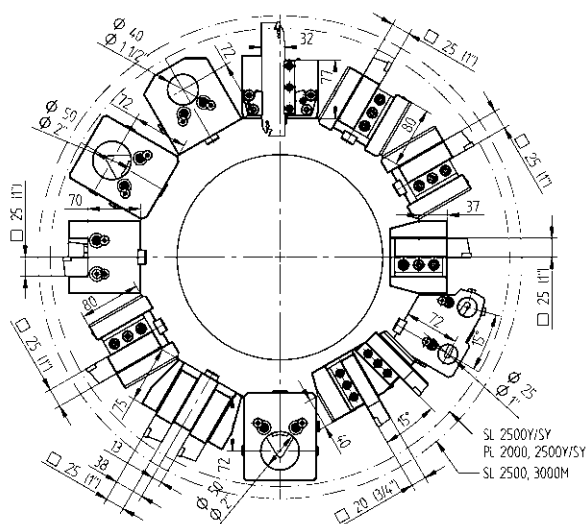

Portautensili statici - Estensione del programma

Portautensili statici - Estensione del programma



**Portautensile doppio, 24 stazioni**

20 48-108749



**Portautensile combinato, universale, doppio, 24 stazioni**

Ø 25 48-108750 IC 80 bar



**Portautensile per lavorazione su mandrino e contromandrino, doppio, 24 stazioni**

20 48-109768



**Portautensile doppio, asse Y**

25(1") 48-86103



**Portautensile per lavorazione su mandrino e contromandrino, doppio, asse Y**

25(1") 48-86150



**Portautensile da taglio, con regolazione**

SH 32 48-99060



**Portautensile da taglio, con regolazione, HP-IC**

SH 32 48-102256R IC 80 bar  
SH 32 48-102256L IC 80 bar



**Portautensile combinato arretrato**

Ø 40 48-102037 IC 80 bar

 241140020 ER32

 241140026 ER40

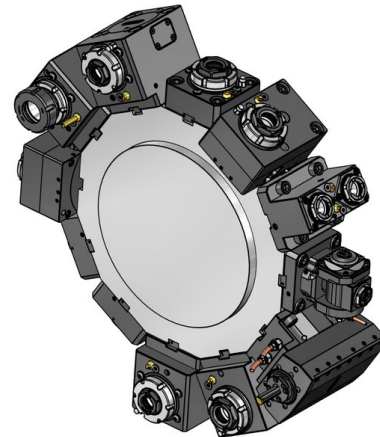
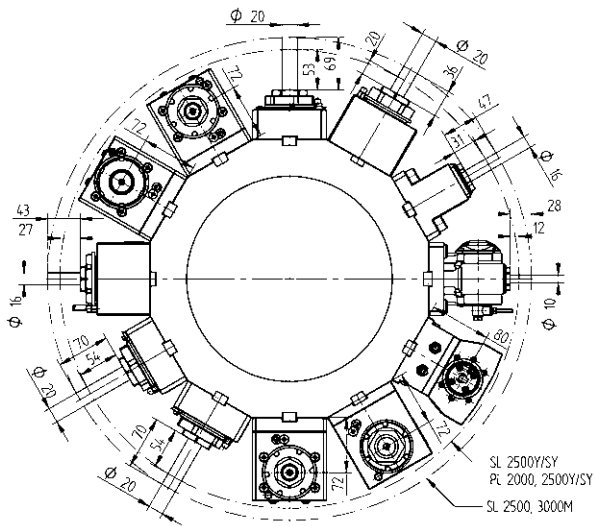

Portautensili Rotanti - QuickFlex®

Portautensili Rotanti - Estensione del programma



**Portautensile rotante di foratura/fresatura**

<b>ER-32 QF</b>	QF32-DNE-BT65A-058-E-A	1:1	EC
	0067732000		
<b>ER-32 QF</b>	QF32-DNE-BT65A-060-I-A	1:1	IC 100 bar
	0067732000		



**Portautensile rotante di foratura/fresatura - QF smart (UE, US, CA, JP)**

<b>ER-32 QF</b>	QF32-DNE-BT65A-060-I-SB-A	1:1	IC 100 bar
	0067732000		

LI-F12-01



**Portautensile rotante di foratura/fresatura, LF=72**

<b>ER-32 QF</b>	420532015-65	1:1	EC
	0067732000		
<b>ER-32 QF</b>	420532016-65	1:1	IC 80 bar
	0067732000		



**Portautensile rotante di foratura/fresatura - QF smart (UE, US, CA, JP), LF=72**

<b>ER-32 QF</b>	QF32-DNI-BT65A-072-I-SB-A	1:1	IC 100 bar
	0067732000		

LI-F12-01



**Portautensile rotante radiale, per lavorazione su mandrino e contromandrino, LF=72**

<b>ER-32 QF</b>	420532017-65	1:1	EC
	0067732000		



**Portautensile rotante di foratura/fresatura**

<b>ER 40</b>	ER40-DNE-BT65A-084-E-A	1:1	EC
	00675000079		
<b>ER 40</b>	ER40-DNE-BT65A-086-I-A	1:1	IC 100 bar
	00675000079		



**Portautensile rotante di foratura/fresatura, disassato**

<b>ER-32 QF</b>	420132037-65	1:1	EC
	0067732000		
<b>ER-32 QF</b>	420132038-65	1:1	IC 80 bar
	0067732000		
<b>ER-25 QF</b>	420125010-65	1:2	EC
	0067725001		
<b>ER-25 QF</b>	420125011-65	1:2	IC 80 bar
	0067725001		



**Portautensile rotante di foratura/fresatura, LF=72**

<b>ER 40</b>	ER40-DNI-BT65A-072-E-A	1:1	EC
	00675000079		
<b>ER 40</b>	ER40-DNI-BT65A-072-I-A	1:1	IC 80 bar
	00675000079		

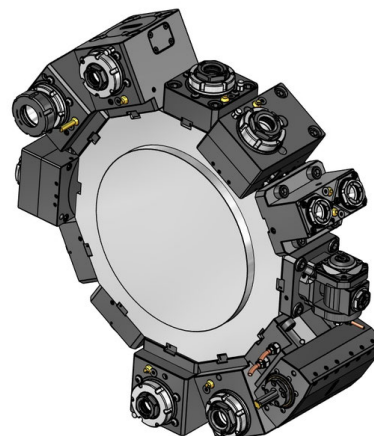
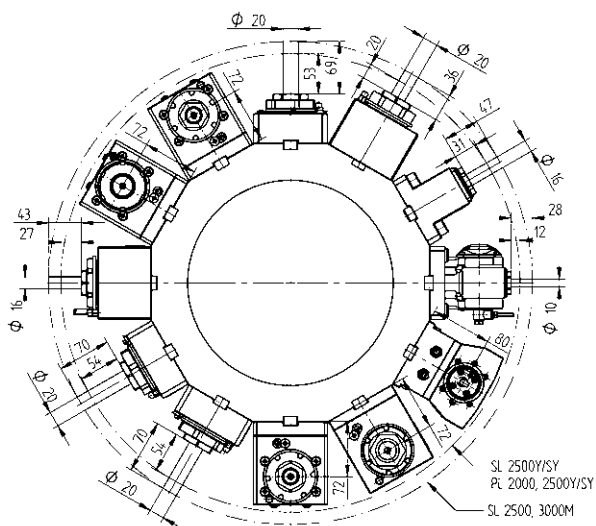

Portautensili Rotanti - Estensione del programma



**Portautensile rotante di foratura/fresatura, LF=72**

<b>ER-25 QF</b>	QF25-DNI-BT65A-072-E-S-A 0067725001	1:2	EC
<b>ER-25 QF</b>	QF25-DNI-BT65A-072-I-S-A 0067725001	1:2	IC 100 bar
<b>ER-32 QF</b>	QF32-DNI-BT65A-072-E-T-A 0067732000	2:1	EC
<b>ER-32 QF</b>	QF32-DNI-BT65A-072-I-T-A 0067732000	2:1	IC 100 bar



**Portautensile rotante orientabile di foratura/fresatura**

<b>ER 16</b>	411010002-65 00675000902	1:1	EC
<b>ER 16</b>	411010003-65 00675000902	1:1	IC 80 bar
<b>ER 11</b>	411007002-65 00675000914	1:2	EC
<b>ER 11</b>	411007003-65 00675000914	1:2	IC 80 bar



**Portautensile rotante di foratura e fresatura, per lavorazione su mandrino e contromandrino**

<b>ER 25</b>	413002005-65 00675000907	1:1	EC
--------------	-----------------------------	-----	----

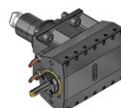

**Unità di brocciatura per interni ed esterni**

<b>Tipo 32</b>	414532001-65	1:1	EC
<b>Tipo 52</b>	414552001-65	1:1	EC

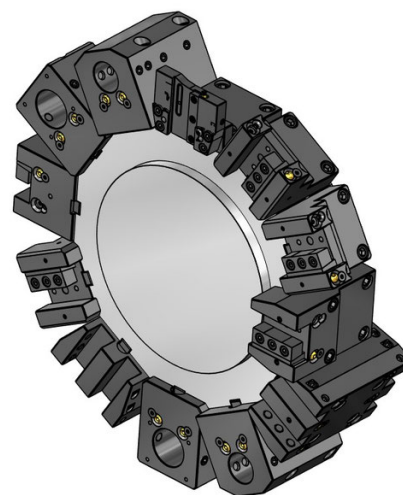
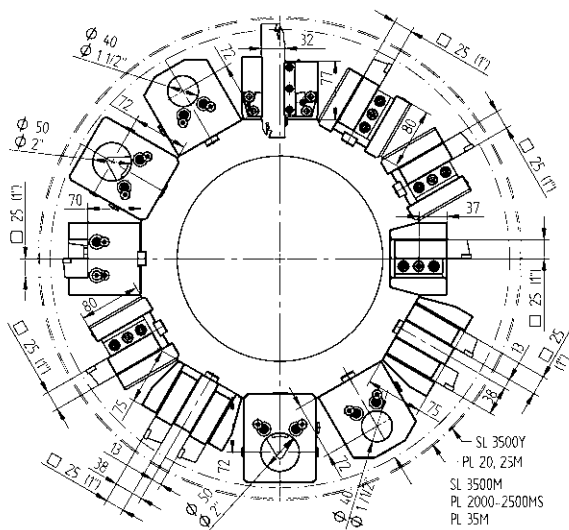

Portautensili statici - Programma standard

Portautensili statici - Programma standard



**Portautensile**

25 48-109110



**Portautensile corto**

25 48-86991



**Portautensile corto, HP-IC**

25 48-86991-HP IC 80 bar



**Portautensile per lavorazione su mandrino e contromandrino**

25 48-109198



**Portautensile per esterni**

25 48-86719



**Portautensile per esterni, HP-IC**

25 48-109249-HP IC 80 bar



**Portautensile per punte, universale, LF=72**

Ø 50 48-109214 IC 80 bar



**Portautensile combinato, LF=72**

Ø 40 48-84375 IC 80 bar  
Ø 50 48-107499 IC 80 bar



**Portautensile combinato (solo per SL 3500Y, torretta a 6 viti)**

Ø 50 48-109013 IC 80 bar



**Portabareno per lavorazione su mandrino e contromandrino**

Ø 40 48-117609



**Coperchio di protezione**

48-87089

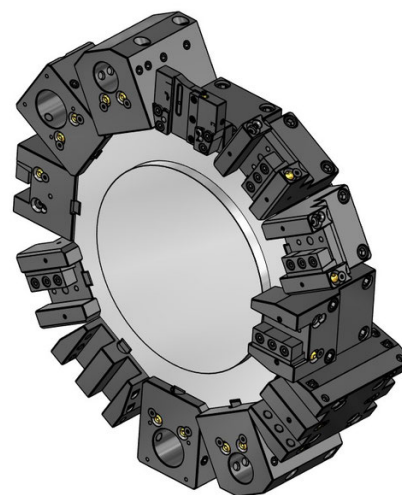
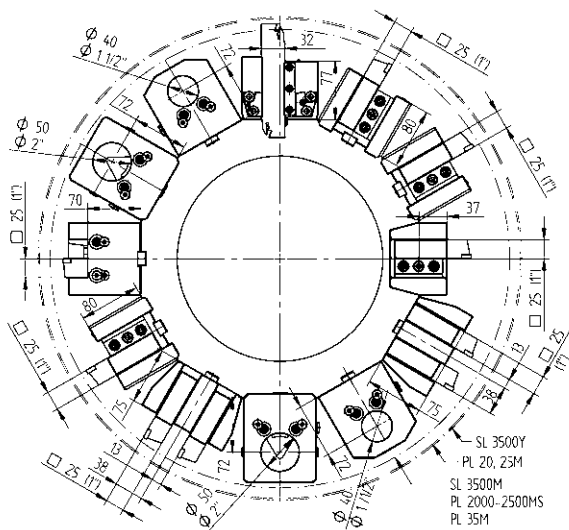

Portautensili statici - Estensione del programma



25(1")

**Portautensile doppio, asse Y**

48-86103



SH 32

**Portautensile da taglio, con regolazione**

48-99060



SH 32

**Portautensile da taglio, con regolazione, HP-IC**

SH 32

48-102256R

IC 80 bar

48-102256L

IC 80 bar



Ø 40

**Portautensile combinato arretrato**

48-102037

IC 80 bar

 241140020 ER32

 241140026 ER40

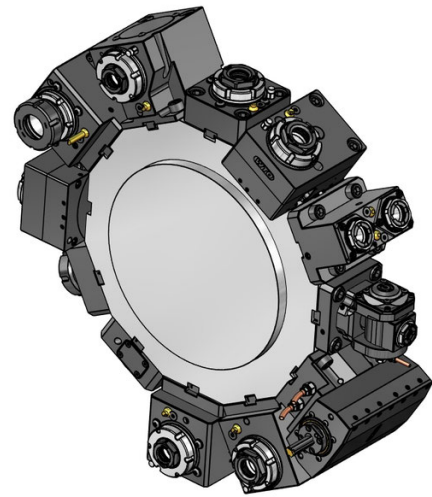
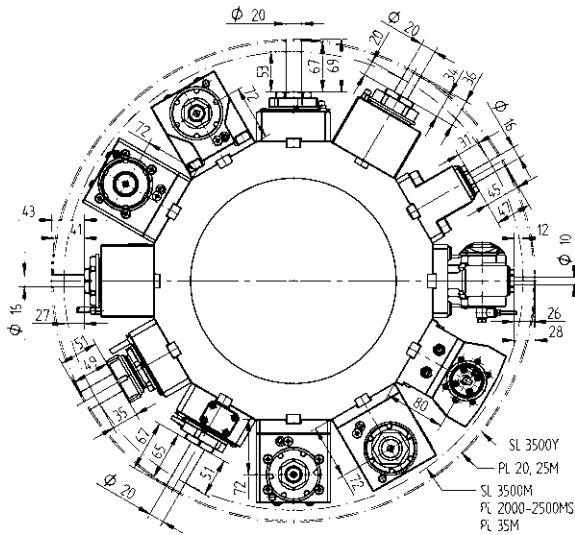

Portautensili Rotanti - QuickFlex®



Portautensile rotante di foratura/fresatura

- |                 |                        |     |            |
|-----------------|------------------------|-----|------------|
| <b>ER-32 QF</b> | QF32-DNE-BT65A-058-E-A | 1:1 | EC         |
|                 | 0067732000             |     |            |
| <b>ER-32 QF</b> | QF32-DNE-BT65A-060-I-A | 1:1 | IC 100 bar |
|                 | 0067732000             |     |            |



Portautensile rotante di foratura/fresatura - QF smart (UE, US, CA, JP)

- |                 |                           |     |            |
|-----------------|---------------------------|-----|------------|
| <b>ER-32 QF</b> | QF32-DNE-BT65A-060-I-SB-A | 1:1 | IC 100 bar |
|                 | 0067732000                |     |            |
|                 | LI-F12-01                 |     |            |



Portautensile rotante di foratura/fresatura, LF=72

- |                 |              |     |           |
|-----------------|--------------|-----|-----------|
| <b>ER-32 QF</b> | 420532015-65 | 1:1 | EC        |
|                 | 0067732000   |     |           |
| <b>ER-32 QF</b> | 420532016-65 | 1:1 | IC 80 bar |
|                 | 0067732000   |     |           |



Portautensile rotante di foratura/fresatura - QF smart (UE, US, CA, JP), LF=72

- |                 |                           |     |            |
|-----------------|---------------------------|-----|------------|
| <b>ER-32 QF</b> | QF32-DNI-BT65A-072-I-SB-A | 1:1 | IC 100 bar |
|                 | 0067732000                |     |            |
|                 | LI-F12-01                 |     |            |



Portautensile rotante radiale, per lavorazione su mandrino e contromandrino, LF=72

- |                 |              |     |    |
|-----------------|--------------|-----|----|
| <b>ER-32 QF</b> | 420532017-65 | 1:1 | EC |
|                 | 0067732000   |     |    |

Portautensili Rotanti - Estensione del programma



Portautensile rotante di foratura/fresatura

- |              |                        |     |            |
|--------------|------------------------|-----|------------|
| <b>ER 40</b> | ER40-DNE-BT65A-084-E-A | 1:1 | EC         |
|              | 00675000079            |     |            |
| <b>ER 40</b> | ER40-DNE-BT65A-086-I-A | 1:1 | IC 100 bar |
|              | 00675000079            |     |            |



Portautensile rotante di foratura/fresatura, disassato

- |                 |              |     |           |
|-----------------|--------------|-----|-----------|
| <b>ER-32 QF</b> | 420132037-65 | 1:1 | EC        |
|                 | 0067732000   |     |           |
| <b>ER-32 QF</b> | 420132038-65 | 1:1 | IC 80 bar |
|                 | 0067732000   |     |           |
| <b>ER-25 QF</b> | 420125010-65 | 1:2 | EC        |
|                 | 0067725001   |     |           |
| <b>ER-25 QF</b> | 420125011-65 | 1:2 | IC 80 bar |
|                 | 0067725001   |     |           |



Portautensile rotante di foratura/fresatura, LF=72

- |              |                        |     |           |
|--------------|------------------------|-----|-----------|
| <b>ER 40</b> | ER40-DNI-BT65A-072-E-A | 1:1 | EC        |
|              | 00675000079            |     |           |
| <b>ER 40</b> | ER40-DNI-BT65A-072-I-A | 1:1 | IC 80 bar |
|              | 00675000079            |     |           |

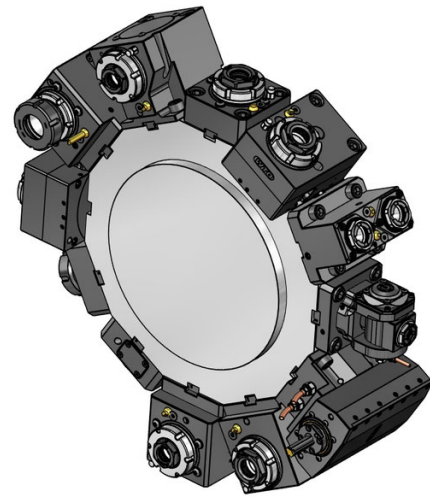
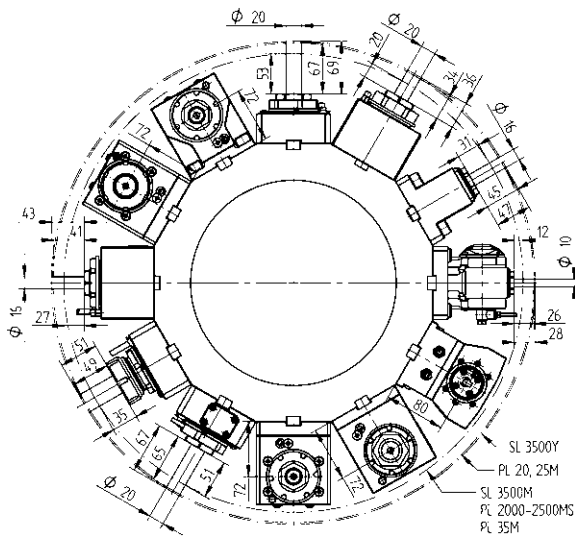

Portautensili Rotanti - Estensione del programma

Portautensili Rotanti - Estensione del programma



**Portautensile rotante di foratura/fresatura, LF=72**

<b>ER-25 QF</b>	QF25-DNI-BT65A-072-E-S-A 0067725001	1:2	EC
<b>ER-25 QF</b>	QF25-DNI-BT65A-072-I-S-A 0067725001	1:2	IC 100 bar
<b>ER-32 QF</b>	QF32-DNI-BT65A-072-E-T-A 0067732000	2:1	EC
<b>ER-32 QF</b>	QF32-DNI-BT65A-072-I-T-A 0067732000	2:1	IC 100 bar



**Portautensile rotante orientabile di foratura/fresatura**

<b>ER 16</b>	411010002-65 00675000902	1:1	EC
<b>ER 16</b>	411010003-65 00675000902	1:1	IC 80 bar
<b>ER 11</b>	411007002-65 00675000914	1:2	EC
<b>ER 11</b>	411007003-65 00675000914	1:2	IC 80 bar



**Unità porta creatore**

<b>Tipo 16-1</b>	411500003-65	1:1	EC
<b>Tipo 16-1</b>	411500002-65	2:1	EC
	00675000927		
	160016161 Ø 16		
	160022161 Ø 22		
	160027161 Ø 27		
	160015161 Ø 5/8"		
	160019161 Ø 3/4"		
	160025161 Ø 1"		
	160031161 Ø 1 1/4"		
	110587		



**Portautensile rotante di foratura e fresatura, per lavorazione su mandrino e contromandrino**

<b>ER 25</b>	413002005-65 00675000907	1:1	EC
--------------	-----------------------------	-----	----

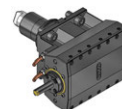

**Unità di brocciatura per interni ed esterni**

<b>Tipo 32</b>	414532001-65	1:1	EC
<b>Tipo 52</b>	414552001-65	1:1	EC



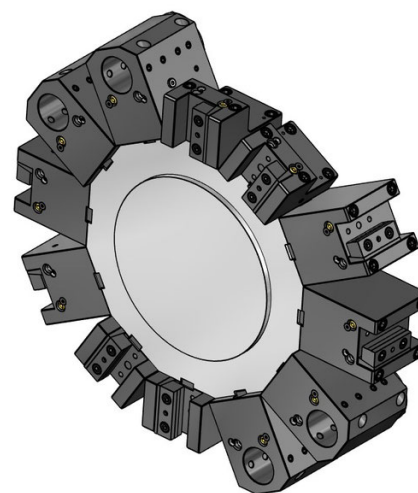
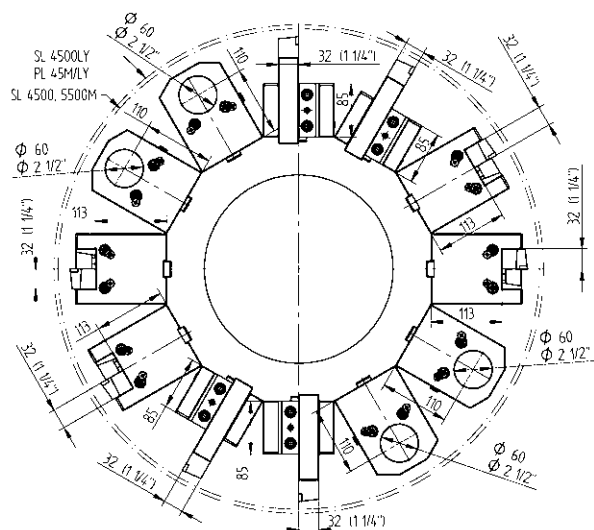

Portautensili statici - Programma standard



32

**Portautensile lungo**

48-96334



32

**Portautensile per esterni lungo**

48-113419



$\phi 60$

**Portautensile combinato, LF=110**

48-96777

IC 80 bar



32

**Portautensile per pezzi lunghi**

48-109821



25(1")

**Portautensile doppio, asse Y**

48-112317



VDI 50

**Adattatore VDI, destro, LF=110**

48-112600

Portautensili statici - Estensione del programma

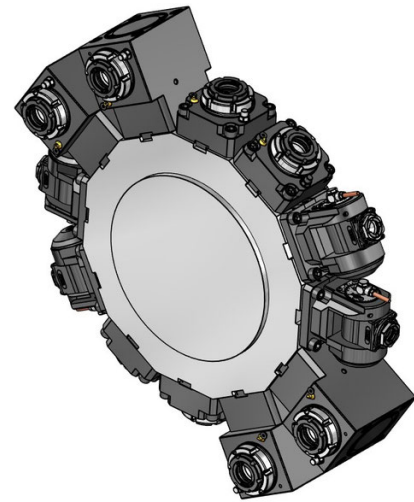
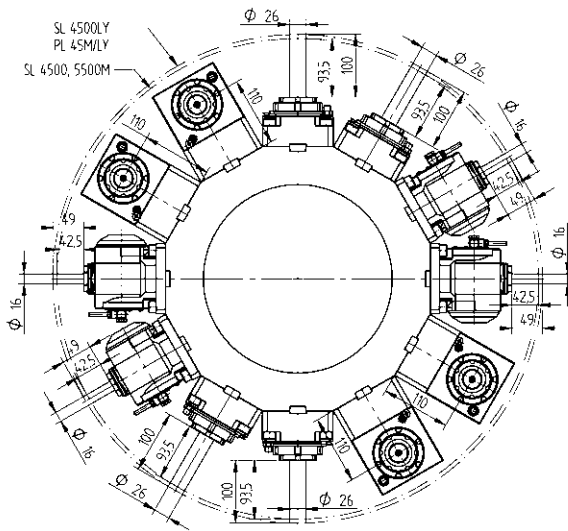

Portautensili Rotanti - QuickFlex®



**Portautensile rotante di foratura/fresatura**

<b>ER-40 QF</b>	420140015-75	1:1	EC
	0067740000		
<b>ER-40 QF</b>	420140016-75	1:1	IC 80 bar
	0067740000		



**Portautensile rotante di foratura/fresatura, LF=110**

<b>ER-40 QF</b>	420540019-75	1:1	EC
	0067740000		
<b>ER-40 QF</b>	420540020-75	1:1	IC 80 bar
	0067740000		

Portautensili Rotanti - Estensione del programma



**Portautensile rotante di foratura/fresatura, LF=110**

<b>ER-32 QF</b>	420532012-75	1:2	EC
	0067732001		
<b>ER-32 QF</b>	420532013-75	1:2	IC 80 bar
	0067732001		
<b>ER-40 QF</b>	420540025-75	2:1	EC
	0067740000		
<b>ER-40 QF</b>	420540026-75	2:1	IC 80 bar
	0067740000		



**Portautensile rotante orientabile di foratura/fresatura**

<b>ER 25</b>	411016000-75	1:1	EC
	00675000934		
<b>ER 25</b>	411016001-75	1:1	IC 80 bar
	00675000934		
<b>ER 16</b>	411010002-75	1:2	EC
	00675000936		
<b>ER 16</b>	411010003-75	1:2	IC 80 bar
	00675000936		

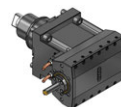

**Unità di brocciatura per interni ed esterni**

<b>Tipo 32</b>	414532000-75	1:1	EC
<b>Tipo 52</b>	414552000-75	1:1	EC

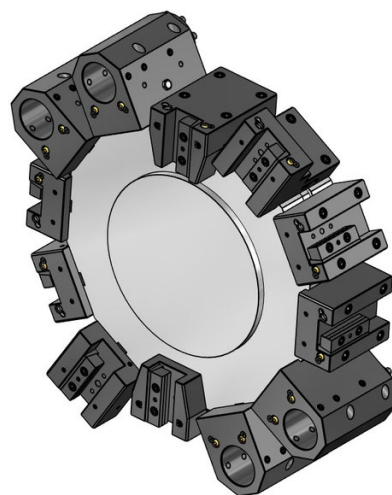
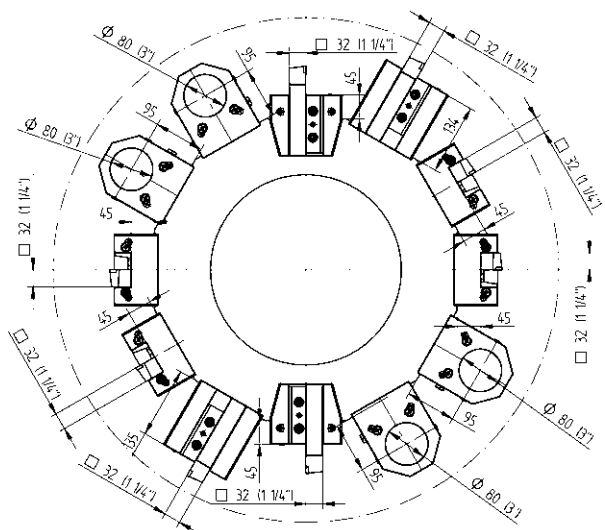

Portautensili statici - Programma standard



**Portautensile**  
32 48-108332



**Portautensile corto**  
32 48-95726



**Portautensile per esterni**  
32 48-95730



**Portautensile combinato**  
Ø 80 48-95732 IC 80 bar

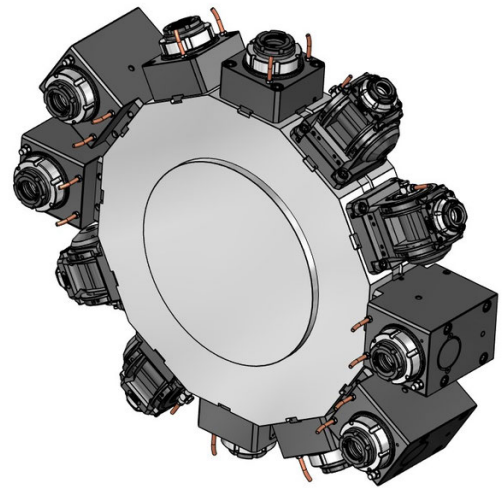
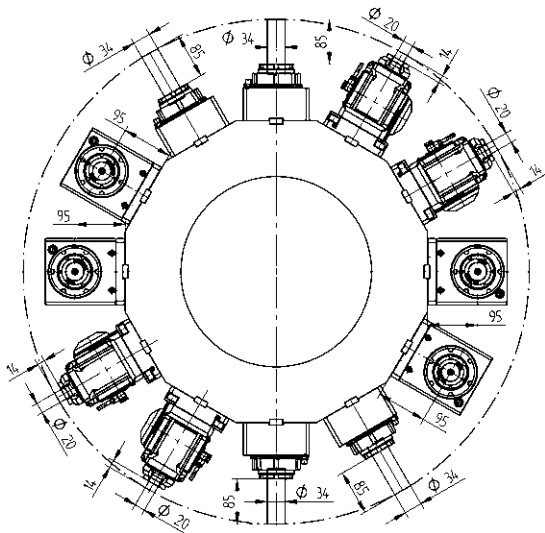

Portautensili Rotanti - QuickFlex®



**Portautensile rotante di foratura/fresatura**

- |                 |              |     |           |
|-----------------|--------------|-----|-----------|
| <b>ER-50 QF</b> | 420150015-85 | 1:1 | EC        |
|                 | 0067750000   |     |           |
| <b>ER-50 QF</b> | 420150016-85 | 1:1 | IC 80 bar |
|                 | 0067750000   |     |           |



**Portautensile rotante di foratura/fresatura portapinze ER, LF=95**

- |                 |              |     |           |
|-----------------|--------------|-----|-----------|
| <b>ER-50 QF</b> | 420550021-85 | 1:1 | EC        |
|                 | 0067750000   |     |           |
| <b>ER-50 QF</b> | 420550022-85 | 1:1 | IC 80 bar |
|                 | 0067750000   |     |           |

Portautensili Rotanti - Estensione del programma



**Portautensile rotante orientabile di foratura/fresatura**

- |                 |              |     |           |
|-----------------|--------------|-----|-----------|
| <b>ER-32 QF</b> | 421032010-85 | 1:1 | EC        |
|                 | 00675000976  |     |           |
| <b>ER-32 QF</b> | 421032011-85 | 1:1 | IC 80 bar |
|                 | 00675000976  |     |           |



**Unità porta creatore**

- |                  |                    |     |    |
|------------------|--------------------|-----|----|
| <b>Tipo C5-1</b> | 410900000-85       | 2:1 | EC |
|                  | 00675001008        |     |    |
|                  | 160022C51 Ø 22     |     |    |
|                  | 160027C51 Ø 27     |     |    |
|                  | 160032C51 Ø 32     |     |    |
|                  | 160019C51 Ø 3/4"   |     |    |
|                  | 160025C51 Ø 1"     |     |    |
|                  | 160031C51 Ø 1 1/4" |     |    |
|                  | 110587             |     |    |

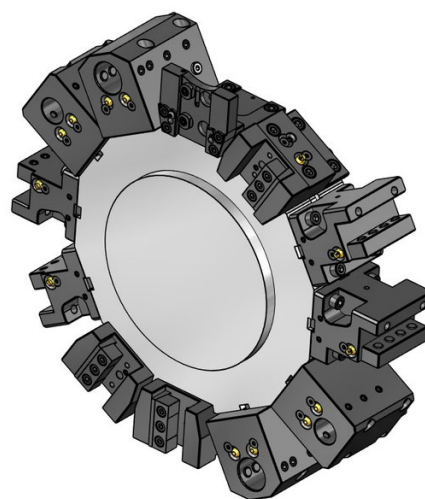
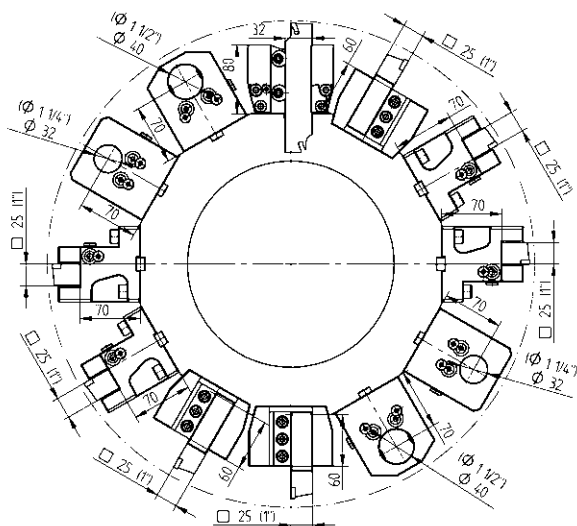

Portautensili statici - Programma standard

- 

**Portautensile**  
25 48-87097
- 

**Portautensile, HP-IC**  
25 48-87097-HP IC 80 bar
- 

**Portautensile per esterni**  
25 48-87101
- 

**Portautensile per esterni, HP-IC**  
25 48-87101-HP IC 80 bar
- 

**Portautensile combinato, LF=70**  
Ø 32 48-106897 IC 80 bar  
Ø 40 48-87103 IC 80 bar

Portautensili statici - Estensione del programma

- 

**Portautensile da taglio, con regolazione**  
SH 32 48-103287
- 

**Portautensile da taglio, con regolazione, HP-IC**  
SH 32 48-110160R IC 80 bar  
SH 32 48-110160L IC 80 bar

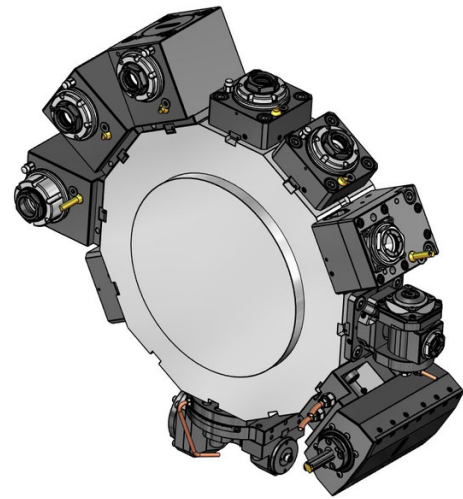
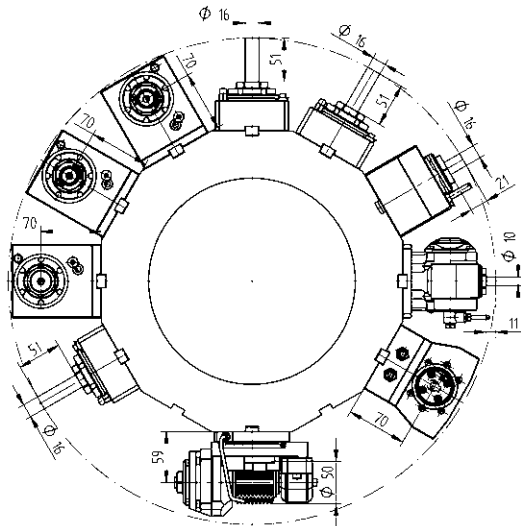

Portautensili Rotanti - QuickFlex®



**Portautensile rotante di foratura/fresatura**

- |                 |              |     |           |
|-----------------|--------------|-----|-----------|
| <b>ER-25 QF</b> | 420125015-55 | 1:1 | EC        |
|                 | 0067725000   |     |           |
| <b>ER-25 QF</b> | 420125016-55 | 1:1 | IC 80 bar |
|                 | 0067725000   |     |           |



**Portautensile rotante di foratura/fresatura, LF=70**

- |                 |              |     |           |
|-----------------|--------------|-----|-----------|
| <b>ER-25 QF</b> | 420525015-55 | 1:1 | EC        |
|                 | 0067725000   |     |           |
| <b>ER-25 QF</b> | 420525016-55 | 1:1 | IC 80 bar |
|                 | 0067725000   |     |           |

Portautensili Rotanti - Estensione del programma



**Portautensile rotante di foratura/fresatura**

- |              |              |     |           |
|--------------|--------------|-----|-----------|
| <b>ER 32</b> | 410120010-55 | 1:1 | EC        |
|              | 0067725000   |     |           |
| <b>ER 32</b> | 410120011-55 | 1:1 | IC 80 bar |
|              | 0067725000   |     |           |



**Portautensile rotante di fresatura con attacco combinato DIN 6358**

- |             |              |     |    |
|-------------|--------------|-----|----|
| <b>Ø 22</b> | 410222004-55 | 1:1 | EC |
|             | 00675000483  |     |    |



**Portautensile rotante di foratura/fresatura, disassato**

- |              |              |     |           |
|--------------|--------------|-----|-----------|
| <b>ER 25</b> | 410116029-55 | 1:1 | EC        |
|              | 00675000932  |     |           |
| <b>ER 25</b> | 410116030-55 | 1:1 | IC 80 bar |
|              | 00675000932  |     |           |
| <b>ER 20</b> | 410113009-55 | 1:2 | EC        |
|              | 00675000939  |     |           |
| <b>ER 20</b> | 410113010-55 | 1:2 | IC 80 bar |
|              | 00675000939  |     |           |
| <b>ER 16</b> | 410410004-55 | 1:3 | EC        |
|              | 00675000937  |     |           |
| <b>ER 16</b> | 410410005-55 | 1:3 | IC 80 bar |
|              | 00675000937  |     |           |

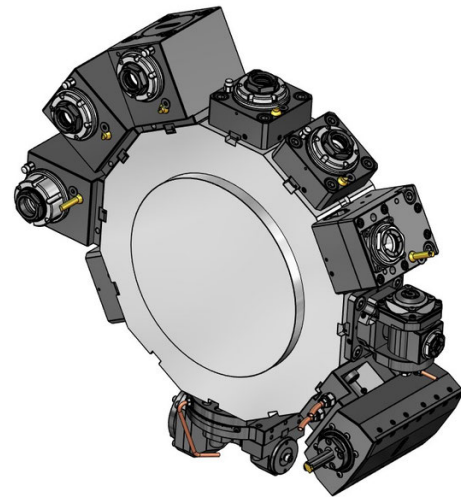
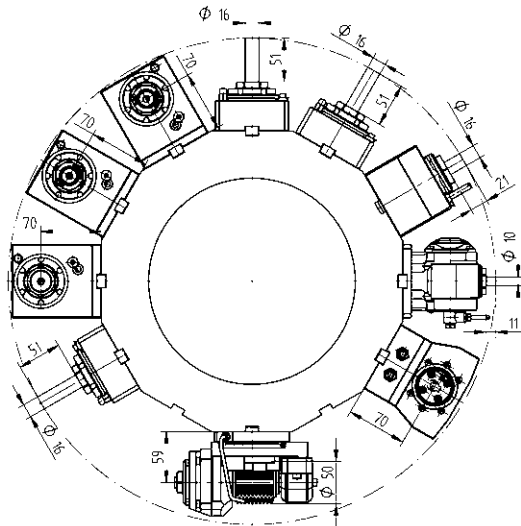

Portautensili Rotanti - Estensione del programma



**Portautensile rotante di foratura/fresatura, LF=70**

<b>ER 32</b>	410520033-55 0067725000	1:1	EC
<b>ER 32</b>	410520034-55 0067725000	1:1	IC 80 bar
<b>ER-20 QF</b>	420520012-55 0067720001	1:2	EC
<b>ER-20 QF</b>	420520013-55 0067720001	1:2	IC 80 bar
<b>ER 16</b>	410810016-55 00675000841	1:3	EC
<b>ER 16</b>	410810017-55 00675000841	1:3	IC 80 bar
<b>ER-25 QF</b>	420525030-55 0067725000	2:1	EC
<b>ER-25 QF</b>	420525031-55 0067725000	2:1	IC 80 bar



**Portautensile rotante radiale portafrese combinato DIN6358, LF=70**

<b>Ø 22</b>	410622010-55 00675000483	1:1	EC
-------------	-----------------------------	-----	----

Portautensili Rotanti - Estensione del programma



**Portautensile rotante orientabile di foratura/fresatura**

<b>ER 16</b>	411010005-55 00675000902	1:1	EC
<b>ER 16</b>	411010006-55 00675000902	1:1	IC 80 bar
<b>ER 11</b>	411007007-55 00675000914	1:2	EC
<b>ER 11</b>	411007008-55 00675000914	1:2	IC 80 bar



**Unità porta creatore**

<b>Tipo 15-2</b>	410900002-55 00675001015	1:1	EC
	160008152 Ø 8		
	160010152 Ø 10		
	160013152 Ø 13		
	160016152 Ø 16		
	160022152 Ø 22		
	160015152 Ø 5/8"		
	160019152 Ø 3/4"		
	110587		

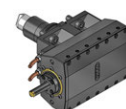

**Unità di brocciatura per interni ed esterni**

<b>Tipo 32</b>	414532001-55	1:1	EC
<b>Tipo 52</b>	414552000-55	1:1	EC

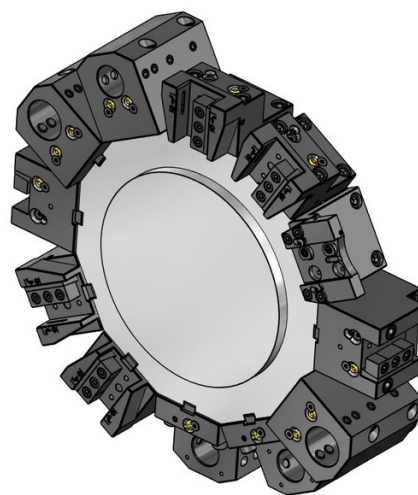
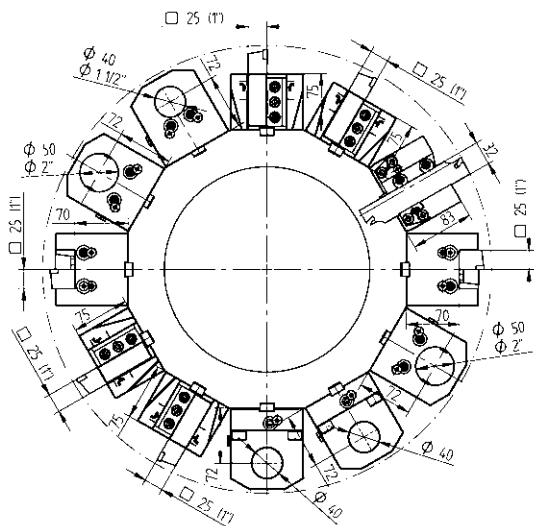

Portautensili statici - Programma standard



**Portautensile**

25 48-92428



**Portautensile, HP-IC**

25 48-92428-HP IC 80 bar



**Portautensile per esterni**

25 48-86719



**Portautensile per esterni, HP-IC**

25 48-109249-HP IC 80 bar



**Portautensile combinato, LF=72**

Ø 40 48-84375 IC 80 bar

Ø 50 48-107499 IC 80 bar



**Coperchio di protezione**

48-87089

Portautensili statici - Estensione del programma



**Portautensile da taglio, con regolazione**

SH 32 48-99060



**Portautensile da taglio, con regolazione, HP-IC**

SH 32 48-102256R IC 80 bar

SH 32 48-102256L IC 80 bar



**Portautensile combinato arretrato**

Ø 40 48-102037 IC 80 bar

241140020 ER32

241140026 ER40



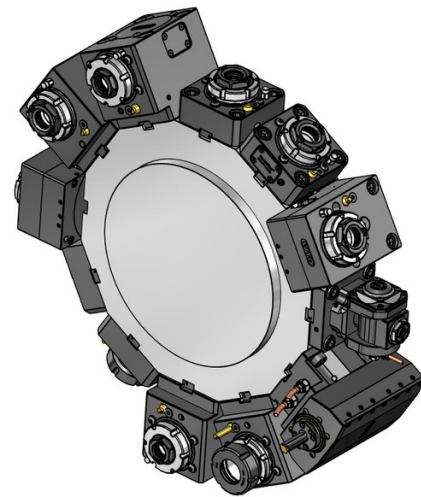
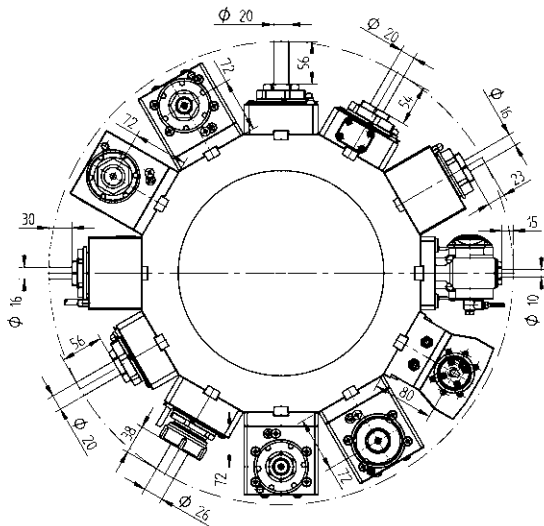

Portautensili Rotanti - QuickFlex®



**Portautensile rotante di foratura/fresatura**

- ER-32 QF** QF32-DNE-BT65A-058-E-A 1:1 EC  
0067732000
- ER-32 QF** QF32-DNE-BT65A-060-I-A 1:1 IC 100 bar  
0067732000



**Portautensile rotante di foratura/fresatura - QF smart (UE, US, CA, JP)**

- ER-32 QF** QF32-DNE-BT65A-060-I-SB-A 1:1 IC 100 bar  
0067732000



**Portautensile rotante di foratura/fresatura, LF=72**

- ER-32 QF** 420532015-65 1:1 EC  
0067732000
- ER-32 QF** 420532016-65 1:1 IC 80 bar  
0067732000



**Portautensile rotante di foratura/fresatura - QF smart (UE, US, CA, JP), LF=72**

- ER-32 QF** QF32-DNI-BT65A-072-I-SB-A 1:1 IC 100 bar  
0067732000



Portautensili Rotanti - Estensione del programma



**Portautensile rotante di foratura/fresatura**

- ER 40** ER40-DNE-BT65A-084-E-A 1:1 EC  
00675000079
- ER 40** ER40-DNE-BT65A-086-I-A 1:1 IC 100 bar  
00675000079



**Portautensile rotante di foratura/fresatura, disassato**

- ER-32 QF** 420132037-65 1:1 EC  
0067732000
- ER-32 QF** 420132038-65 1:1 IC 80 bar  
0067732000
- ER-25 QF** 420125010-65 1:2 EC  
0067725001
- ER-25 QF** 420125011-65 1:2 IC 80 bar  
0067725001



**Portautensile rotante di foratura/fresatura, LF=72**

- ER 40** ER40-DNI-BT65A-072-E-A 1:1 EC  
00675000079
- ER 40** ER40-DNI-BT65A-072-I-A 1:1 IC 80 bar  
00675000079

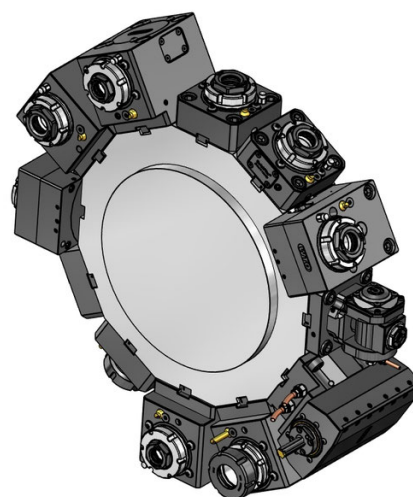
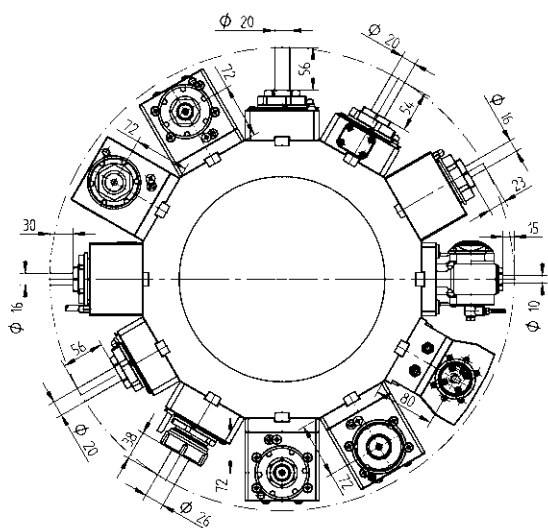

Portautensili Rotanti - Estensione del programma



**Portautensile rotante di foratura/fresatura, LF=72**

<b>ER-25 QF</b>	QF25-DNI-BT65A-072-E-S-A 0067725001	1:2	EC
<b>ER-25 QF</b>	QF25-DNI-BT65A-072-I-S-A 0067725001	1:2	IC 100 bar
<b>ER-32 QF</b>	QF32-DNI-BT65A-072-E-T-A 0067732000	2:1	EC
<b>ER-32 QF</b>	QF32-DNI-BT65A-072-I-T-A 0067732000	2:1	IC 100 bar

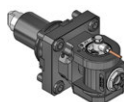

**Portautensile rotante orientabile di foratura/fresatura**

<b>ER 16</b>	411010002-65 00675000902	1:1	EC
<b>ER 16</b>	411010003-65 00675000902	1:1	IC 80 bar
<b>ER 11</b>	411007002-65 00675000914	1:2	EC
<b>ER 11</b>	411007003-65 00675000914	1:2	IC 80 bar



**Unità di brocciatura per interni ed esterni**

<b>Tipo 32</b>	414532001-65	1:1	EC
<b>Tipo 52</b>	414552001-65	1:1	EC

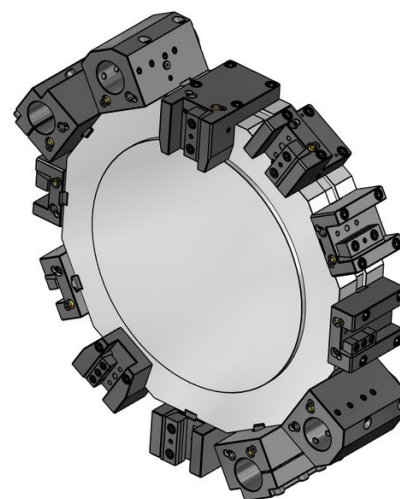
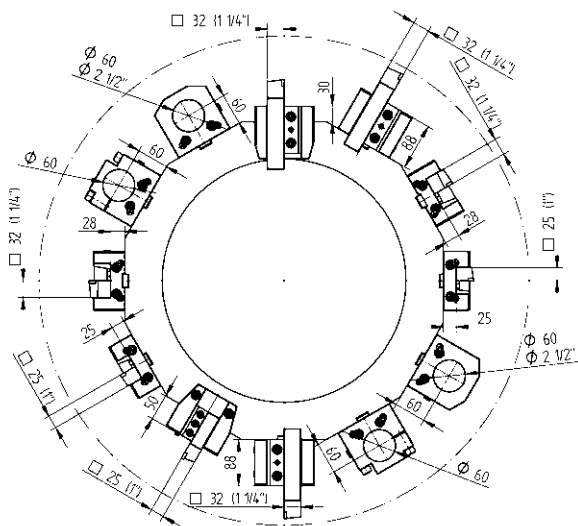

Portautensili statici - Programma standard



**25** Portautensile

48-96421



**25** Portautensile, HP-IC

48-96421-HP IC 80 bar



**32** Portautensile

48-112326R  
48-112326L



**32** Portautensile lungo

48-96334



**25** Portautensile per esterni

48-96355



**32** Portautensile per esterni

48-112328R  
48-112328L



**Ø 60** Portautensile combinato, LF=60

48-96759 IC 80 bar

Portautensili statici - Programma standard



**Ø 60** Portabareno con serraggio a morsetto, LF=60

48-97849



**VDI 50** Adattatore VDI, destro, LF=60

48-97345

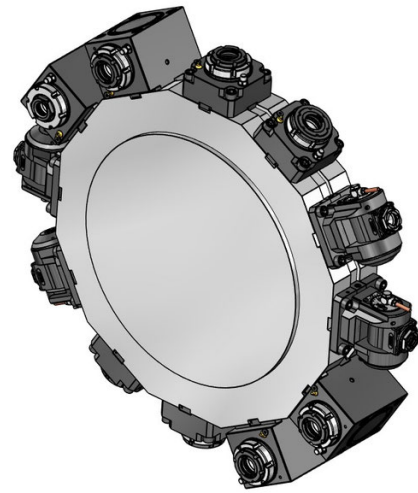
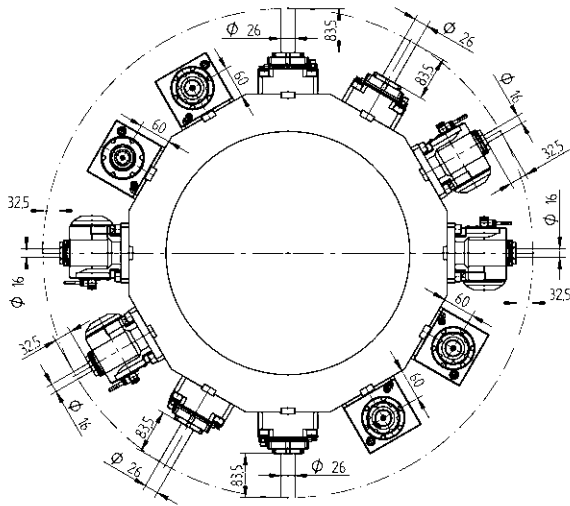

Portautensili Rotanti - QuickFlex®



**Portautensile rotante di foratura/fresatura**

<b>ER-40 QF</b>	420140015-75	1:1	EC
	0067740000		
<b>ER-40 QF</b>	420140016-75	1:1	IC 80 bar
	0067740000		



**Portautensile rotante di foratura/fresatura, LF=60**

<b>ER-40 QF</b>	420540015-75	1:1	EC
	0067740000		
<b>ER-40 QF</b>	420540016-75	1:1	IC 80 bar
	0067740000		

Portautensili Rotanti - Estensione del programma



**Portautensile rotante di foratura/fresatura, LF=60**

<b>ER-32 QF</b>	420532010-75	1:2	EC
	0067732001		
<b>ER-32 QF</b>	420532011-75	1:2	IC 80 bar
	0067732001		
<b>ER-40 QF</b>	420540021-75	2:1	EC
	0067740000		
<b>ER-40 QF</b>	420540022-75	2:1	IC 80 bar
	0067740000		



**Portautensile rotante orientabile di foratura/fresatura**

<b>ER 25</b>	411016000-75	1:1	EC
	00675000934		
<b>ER 25</b>	411016001-75	1:1	IC 80 bar
	00675000934		
<b>ER 16</b>	411010002-75	1:2	EC
	00675000936		
<b>ER 16</b>	411010003-75	1:2	IC 80 bar
	00675000936		

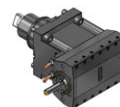

**Unità di brocciatura per interni ed esterni**

<b>Tipo 32</b>	414532000-75	1:1	EC
<b>Tipo 52</b>	414552000-75	1:1	EC

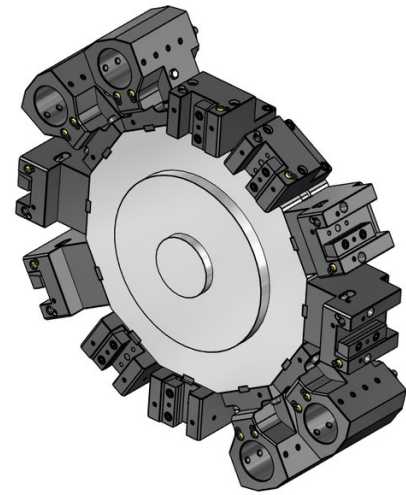
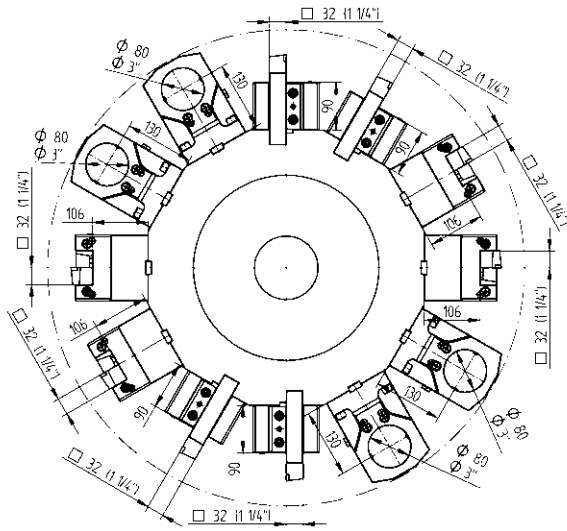

Portautensili statici - Programma standard



**Portautensile**  
32 48-108935



**Portautensile per esterni**  
32 48-108937



**Portautensile combinato**  
Ø 80 48-108939 IC 80 bar

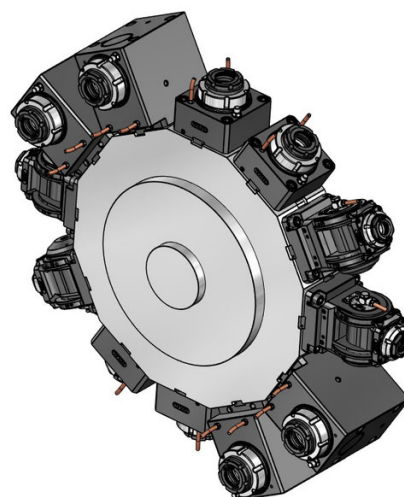
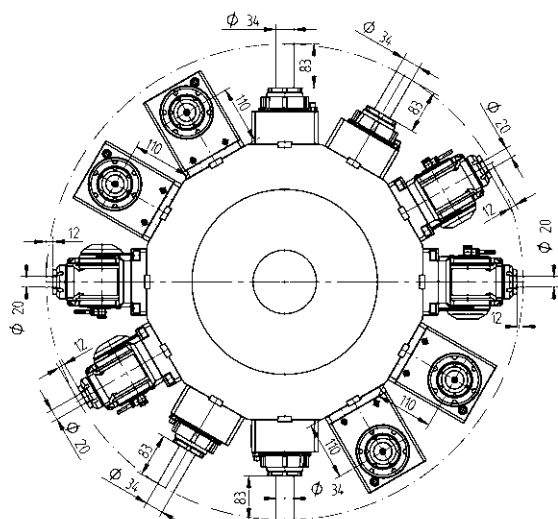

Portautensili Rotanti - QuickFlex®

Portautensili Rotanti - Estensione del programma



**Portautensile rotante di foratura/fresatura**

- |                 |              |     |           |
|-----------------|--------------|-----|-----------|
| <b>ER-50 QF</b> | 420150015-85 | 1:1 | EC        |
|                 | 0067750000   |     |           |
| <b>ER-50 QF</b> | 420150016-85 | 1:1 | IC 80 bar |
|                 | 0067750000   |     |           |



**Portautensile rotante orientabile di foratura/fresatura**

- |                 |              |     |           |
|-----------------|--------------|-----|-----------|
| <b>ER-32 QF</b> | 421032010-85 | 1:1 | EC        |
|                 | 00675000976  |     |           |
| <b>ER-32 QF</b> | 421032011-85 | 1:1 | IC 80 bar |
|                 | 00675000976  |     |           |



**Portautensile rotante di foratura/fresatura, LF=110**

- |                 |              |     |           |
|-----------------|--------------|-----|-----------|
| <b>ER-50 QF</b> | 420550017-85 | 1:1 | EC        |
|                 | 0067750000   |     |           |
| <b>ER-50 QF</b> | 420550018-85 | 1:1 | IC 80 bar |
|                 | 0067750000   |     |           |

Bussole cilindriche standard di riduzione



**Bussola di riduzione Ø 25**

240025006	Ø 6
240025008	Ø 8
240025010	Ø 10
240025012	Ø 12
240025014	Ø 14
240025016	Ø 16
240025020	Ø 20

Bussole cilindriche standard di riduzione



**Bussola di riduzione Ø 80**

240080020	Ø 20
240080025	Ø 25
240080032	Ø 32
240080040	Ø 40
240080050	Ø 50
240080060	Ø 60



**Bussola di riduzione Ø 32**

240032006	Ø 6
240032008	Ø 8
240032010	Ø 10
240032012	Ø 12
240032014	Ø 14
240032016	Ø 16
240032018	Ø 18
240032020	Ø 20
240032025	Ø 25



**Bussola di riduzione Ø 40**

240040006	Ø 6
240040008	Ø 8
240040010	Ø 10
240040012	Ø 12
240040014	Ø 14
240040016	Ø 16
240040020	Ø 20
240040025	Ø 25
240040032	Ø 32



**Bussola di riduzione Ø 50**

240050010	Ø 10
240050012	Ø 12
240050016	Ø 16
240050020	Ø 20
240050025	Ø 25
240050032	Ø 32
240050040	Ø 40



**Bussola di riduzione Ø 60**

240060012	Ø 12
240060016	Ø 16
240060020	Ø 20
240060025	Ø 25
240060032	Ø 32
240060040	Ø 40
240060050	Ø 50

Bussole di riduzione standard cono Morse

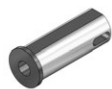

**Bussola di riduzione Ø 32**

240532001	MT 1
240532002	MT 2
240532003	MT 3



**Bussola di riduzione Ø 40**

240540001	MT 1
240540002	MT 2
240540003	MT 3
240540004	MT 4

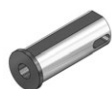

**Bussola di riduzione Ø 50**

240550002	MT 2
240550003	MT 3
240550004	MT 4



Pinze DIN 6499B (ER/ESX)

Pinze DIN 6499B (ER/ESX)



**ER 11**

190011000	∅ 7-0.5	∅ 0.276-0.020
190011010	∅ 1-0.5	∅ 0.039-0.020
190011015	∅ 1.5-1	∅ 0.059-0.039
190011020	∅ 2-1.5	∅ 0.079-0.059
190011025	∅ 2.5-2	∅ 0.098-0.079
190011030	∅ 3-2.5	∅ 0.118-0.098
190011035	∅ 3.5-3	∅ 0.138-0.118
190011040	∅ 4-3.5	∅ 0.158-0.138
190011045	∅ 4.5-4	∅ 0.177-0.158
190011050	∅ 5-4.5	∅ 0.197-0.177
190011055	∅ 5.5-5	∅ 0.217-0.197
190011060	∅ 6-5.5	∅ 0.236-0.217
190011065	∅ 6.5-6	∅ 0.256-0.236
190011070	∅ 7-6.5	∅ 0.276-0.256



**ER 25**

190025000	∅ 16-1	∅ 0.630-0.039
190025010	∅ 1-0.5	∅ 0.039-0.020
190025020	∅ 2-1	∅ 0.079-0.039
190025030	∅ 3-2	∅ 0.118-0.079
190025040	∅ 4-3	∅ 0.157-0.118
190025050	∅ 5-4	∅ 0.197-0.157
190025060	∅ 6-5	∅ 0.236-0.197
190025070	∅ 7-6	∅ 0.276-0.236
190025080	∅ 8-7	∅ 0.315-0.276
190025090	∅ 9-8	∅ 0.354-0.315
190025100	∅ 10-9	∅ 0.394-0.354
190025110	∅ 11-10	∅ 0.433-0.394
190025120	∅ 12-11	∅ 0.472-0.433
190025130	∅ 13-12	∅ 0.512-0.472
190025140	∅ 14-13	∅ 0.551-0.512
190025150	∅ 15-14	∅ 0.591-0.551
190025160	∅ 16-15	∅ 0.630-0.591



**ER 16**

190016000	∅ 10-0.5	∅ 0.394-0.020
190016010	∅ 1-0.5	∅ 0.039-0.020
190016020	∅ 2-1	∅ 0.079-0.039
190016030	∅ 3-2	∅ 0.118-0.079
190016040	∅ 4-3	∅ 0.158-0.118
190016050	∅ 5-4	∅ 0.197-0.158
190016060	∅ 6-5	∅ 0.236-0.197
190016070	∅ 7-6	∅ 0.276-0.236
190016080	∅ 8-7	∅ 0.315-0.276
190016090	∅ 9-8	∅ 0.354-0.315
190016100	∅ 10-9	∅ 0.394-0.354



**ER 32**

190032000	∅ 20-2	∅ 0.787-0.079
190032020	∅ 2-1	∅ 0.079-0.039
190032030	∅ 3-2	∅ 0.118-0.079
190032040	∅ 4-3	∅ 0.157-0.118
190032050	∅ 5-4	∅ 0.197-0.157
190032060	∅ 6-5	∅ 0.236-0.197
190032070	∅ 7-6	∅ 0.276-0.236
190032080	∅ 8-7	∅ 0.315-0.276
190032090	∅ 9-8	∅ 0.354-0.315
190032100	∅ 10-9	∅ 0.394-0.354
190032110	∅ 11-10	∅ 0.433-0.394
190032120	∅ 12-11	∅ 0.472-0.433
190032130	∅ 13-12	∅ 0.512-0.472
190032140	∅ 14-13	∅ 0.551-0.512
190032150	∅ 15-14	∅ 0.591-0.551
190032160	∅ 16-15	∅ 0.630-0.591
190032170	∅ 17-16	∅ 0.669-0.630
190032180	∅ 18-17	∅ 0.709-0.669
190032190	∅ 19-18	∅ 0.748-0.709
190032200	∅ 20-19	∅ 0.787-0.748



**ER 20**

190020000	∅ 13-1	∅ 0.512-0.039
190020010	∅ 1-0.5	∅ 0.039-0.020
190020020	∅ 2-1	∅ 0.079-0.039
190020030	∅ 3-2	∅ 0.118-0.079
190020040	∅ 4-3	∅ 0.157-0.118
190020050	∅ 5-4	∅ 0.197-0.157
190020060	∅ 6-5	∅ 0.236-0.197
190020070	∅ 7-6	∅ 0.276-0.236
190020080	∅ 8-7	∅ 0.315-0.276
190020090	∅ 9-8	∅ 0.354-0.315
190020100	∅ 10-9	∅ 0.394-0.354
190020110	∅ 11-10	∅ 0.433-0.394
190020120	∅ 12-11	∅ 0.472-0.433
190020130	∅ 13-12	∅ 0.512-0.472

Pinze DIN 6499B (ER/ESX)



**ER 40**

190040000	ø 26-3	ø 1.024-0.118
190040030	ø 3-2	ø 0.118-0.079
190040040	ø 4-3	ø 0.157-0.118
190040050	ø 5-4	ø 0.197-0.157
190040060	ø 6-5	ø 0.236-0.197
190040070	ø 7-6	ø 0.276-0.236
190040080	ø 8-7	ø 0.315-0.276
190040090	ø 9-8	ø 0.354-0.315
190040100	ø 10-9	ø 0.394-0.354
190040110	ø 11-10	ø 0.433-0.394
190040120	ø 12-11	ø 0.472-0.433
190040130	ø 13-12	ø 0.512-0.472
190040140	ø 14-13	ø 0.551-0.512
190040150	ø 15-14	ø 0.591-0.551
190040160	ø 16-15	ø 0.630-0.591
190040170	ø 17-16	ø 0.669-0.630
190040180	ø 18-17	ø 0.709-0.669
190040190	ø 19-18	ø 0.748-0.709
190040200	ø 20-19	ø 0.787-0.748
190040210	ø 21-20	ø 0.827-0.787
190040220	ø 22-21	ø 0.866-0.827
190040230	ø 23-22	ø 0.906-0.866
190040240	ø 24-23	ø 0.945-0.906
190040250	ø 25-24	ø 0.984-0.945
190040260	ø 26-25	ø 1.024-0.984



**ER 50**

190050000	ø 34-10	ø 1.339-0.394
190050060	ø 6-4	ø 0.236-0.157
190050080	ø 8-6	ø 0.315-0.236
190050100	ø 10-8	ø 0.394-0.315
190050120	ø 12-10	ø 0.472-0.394
190050140	ø 14-12	ø 0.551-0.472
190050160	ø 16-14	ø 0.630-0.551
190050180	ø 18-16	ø 0.709-0.630
190050200	ø 20-18	ø 0.787-0.709
190050220	ø 22-20	ø 0.866-0.787
190050240	ø 24-22	ø 0.945-0.866
190050260	ø 26-24	ø 1.024-0.945
190050280	ø 28-26	ø 1.102-1.024
190050300	ø 30-28	ø 1.181-1.102
190050320	ø 32-30	ø 1.260-1.181
190050340	ø 32-30	ø 1.260-1.181

Pinze DIN 6499B (ER/ESX) - vulcanizzate per refrigerante



**ER 11**

191011030	ø 3
191011040	ø 4
191011050	ø 5
191011060	ø 6



**ER 16**

191016000	ø 3-10
191016030	ø 3
191016040	ø 4
191016050	ø 5
191016060	ø 6
191016070	ø 7
191016080	ø 8
191016090	ø 9
191016100	ø 10



**ER 20**

191020000	ø 3-12
191020030	ø 3
191020040	ø 4
191020050	ø 5
191020060	ø 6
191020070	ø 7
191020080	ø 8
191020090	ø 9
191020100	ø 10
191020110	ø 11
191020120	ø 12



**ER 25**

191025000	ø 4-16
191025030	ø 3
191025040	ø 4
191025050	ø 5
191025060	ø 6
191025070	ø 7
191025080	ø 8
191025090	ø 9
191025100	ø 10
191025110	ø 11
191025120	ø 12
191025130	ø 13
191025140	ø 14
191025150	ø 15
191025160	ø 16

Pinze DIN 6499B (ER/ESX) - vulcanizzate  
per refrigerante



**ER 32**

191032000	ø 4-20
191032030	ø 3
191032040	ø 4
191032050	ø 5
191032060	ø 6
191032070	ø 7
191032080	ø 8
191032090	ø 9
191032100	ø 10
191032110	ø 11
191032120	ø 12
191032130	ø 13
191032140	ø 14
191032150	ø 15
191032160	ø 16
191032170	ø 17
191032180	ø 18
191032190	ø 19
191032200	ø 20



**ER 40**

191040060	ø 6
191040080	ø 8
191040100	ø 10
191040120	ø 12
191040140	ø 14
191040160	ø 16
191040180	ø 18
191040200	ø 20
191040220	ø 22
191040250	ø 25

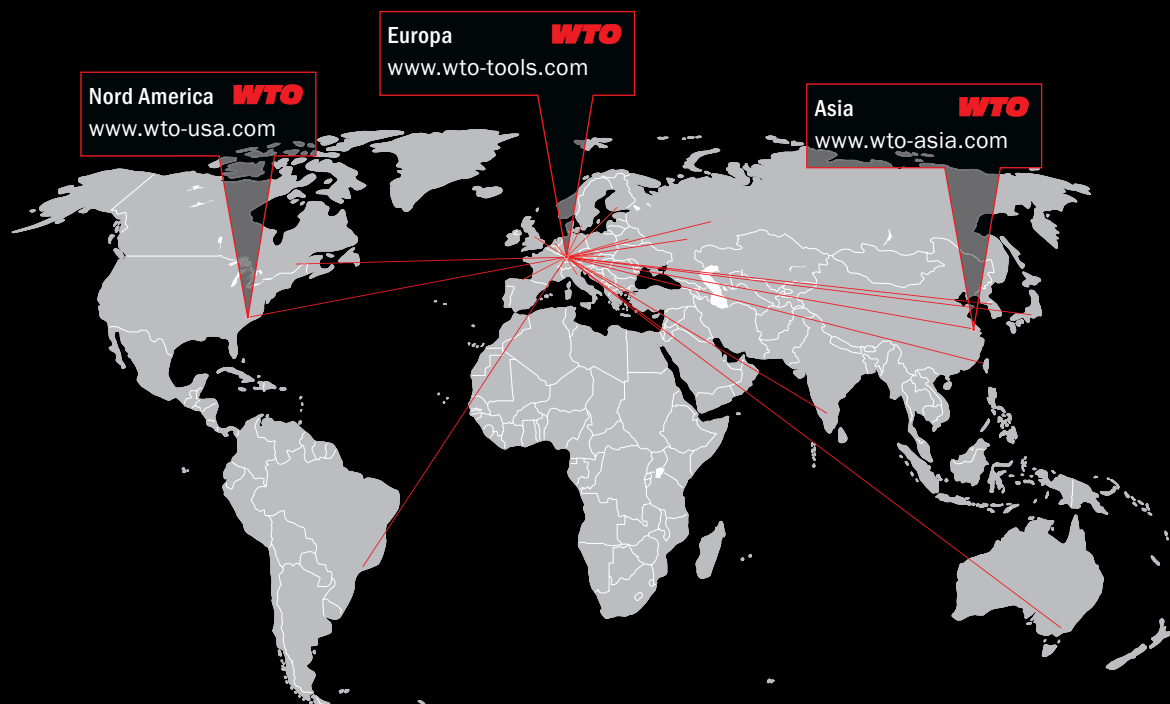

WTO  
Werkzeug-  
Einrichtungen GmbH  
Neuer Hohdammweg 1  
77797 Ohlsbach  
Germania

WTO Inc.  
13900-F South Lakes Dr.  
Charlotte, NC 28273  
Stati Uniti d'America

WTO Asia  
WTO Precision Tool Holders  
(Shanghai) Co. Ltd.  
Room 109-110, Building 2  
No. 228 Banting Road  
Jiuting Town,  
Songjiang District  
201615 Shanghai  
Cina

## Our distribution partners. Competence right there.

**Australia**  
Dimac Tooling Ltd.  
sales@dimac.com.au

**Francia, est**  
Alexandre Mathelin  
alm@wto.de

**Korea**  
WTO Office Korea  
is.chon@wto-korea.com

**Spain**  
ITALMATIC, S.A.  
italmatic@italmatic.es

**Brazil**  
TF2  
tfdois@tfdois.com.br

**Francia, ovest**  
Christophe Archambault  
car@wto.de

**Messico**  
Workholding Engineering De México  
info@wem.com.mx

**Sweden**  
Bonthron & Ewing AB  
info@bonthron-ewing.se

**Canada**  
Mittmann Industrial Inc.  
info@mittmann.com

**Great Britain**  
Cutwel Ltd.  
sales@cutwel.net

**Netherlands**  
Toologic BeNeLux B.V.  
info@toologic-benelux.nl

**Switzerland**  
Utilis AG  
info@utilis.com

**China**  
Shanghai Gangde  
wtocando@yahoo.com

**India**  
Ulhas Patil  
u.patil@wto-asia.com

**Norway**  
Helge Karlsen Verktøy og Maskin AS  
hkvm@hkvm.no

**Taiwan**  
Kaiko Co., Ltd.  
info@kaiko.com.tw

**Czech Republic**  
ALBA precision, spol. s.r.o.  
info@albaprecision.cz

**Israel**  
E.Y.A.R. Ltd.  
boris@eyar.co.il

**Polonia**  
ARCO Andrzej Rudenko  
info@arcotools.pl

**Turkey**  
MYK CNC MAKINA SAN. VE  
huseyin.tatlidil@mykcnc.com.tr

**Denmark**  
AVN Teknik A/S  
cjo@avn.dk

**Italy**  
Prymark srl  
commerciale@prymark.it

**Romania**  
SC Elif Trading SRL  
bulent.ozkan@eliftrading.com

**Ukraine**  
„LLC“ SPA Stankopromimport  
info@phoenix-ua.com

**Finland**  
Suomen Terätuonti Oy  
myynti@stt.as

**Japan**  
NK Works Co. Ltd.  
k\_samba@nk-works.co.jp

**Slowakia**  
ALBA precision s.r.o.  
albaprecision@albaprecision.sk

**Ungheria**  
Prevotex Hungary Kft.  
info@prevotex.hu